

Genie®



Operator's Manual *with Maintenance Information*

Third Edition
First Printing
Part No. 97780

TZ™-34/20

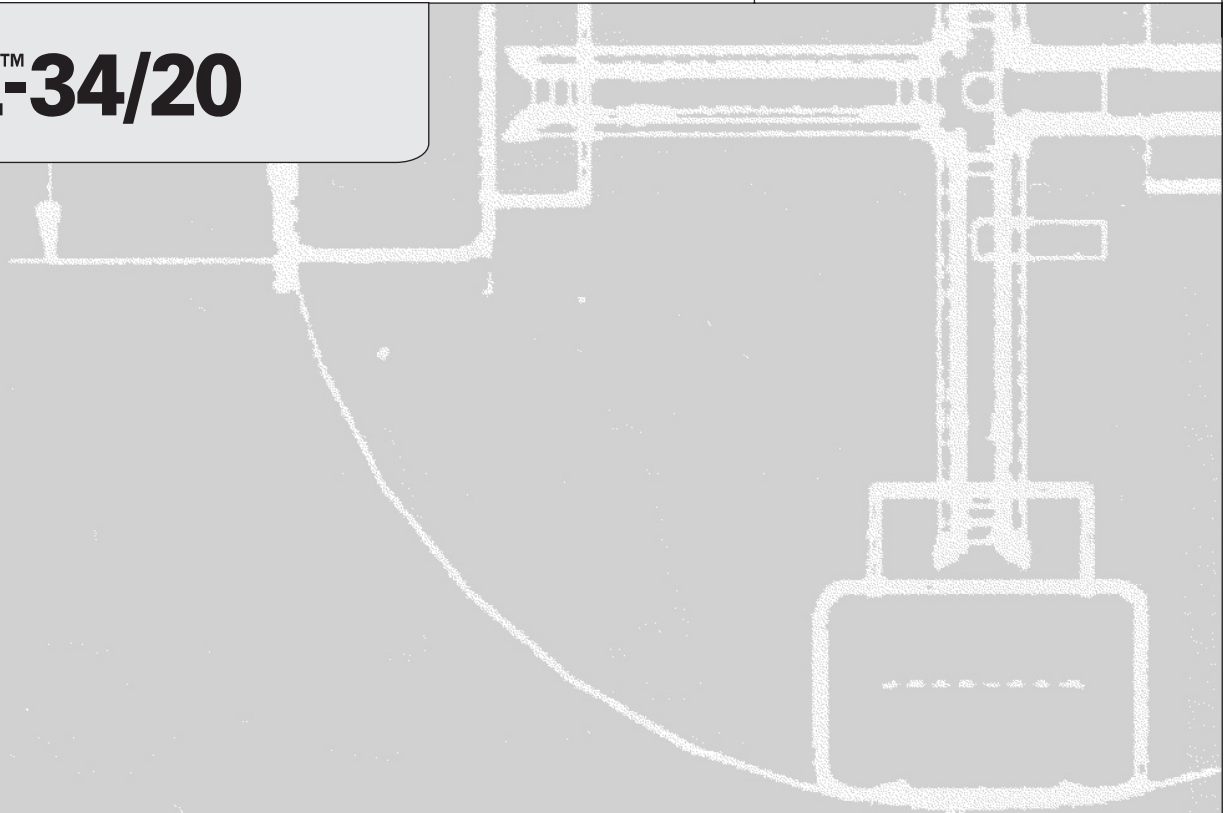

Important

Read, understand and obey these safety rules and operating instructions before operating this machine. Only trained and authorized personnel shall be permitted to operate this machine. This manual should be considered a permanent part of your machine and should remain with the machine at all times. If you have any questions, call Genie Industries.

Contents

	Page
Safety	1
Controls	8
Pre-operation Inspection	10
Maintenance	12
Function Tests	15
Workplace Inspection	20
Operating Instructions	21
Transport and Lifting Instructions	26
Decals	28
Specifications	32
Reporting Safety Defects	34

Contact us:

Internet: <http://www.genielift.com>
 e-mail: techpub@genieind.com

Copyright © 2003 by Genie Industries

First Edition: First Printing, April 2003

Second Edition: Fifth Printing, February 2004

Third Edition: First Printing, November 2004

"Genie" is a registered trademark of Genie Industries in the USA and many other countries.

These machines comply with ANSI/SIA 92.2-2001.

 Printed on recycled paper

Printed in U.S.A.

Safety Rules



Danger

Failure to obey the instructions and safety rules in this manual will result in death or serious injury.

Do Not Operate Unless:

- You learn and practice the principles of safe machine operation contained in this operator's manual.

1 Avoid hazardous situations.

Know and understand the safety rules before going on to the next section.

- 2 Always perform a pre-operation inspection.
- 3 Always perform function tests prior to use.
- 4 Inspect the workplace.
- 5 Only use the machine as it was intended.

- You read, understand and obey the manufacturer's instructions and safety rules—safety and operator's manuals and machine decals.
- You read, understand and obey employer's safety rules and worksite regulations.
- You read, understand and obey all applicable governmental regulations.
- You are properly trained to safely operate the machine.

SAFETY RULES

Electrocution Hazards

This machine is **not** electrically insulated and will **not** provide protection from contact with or proximity to electrical current.

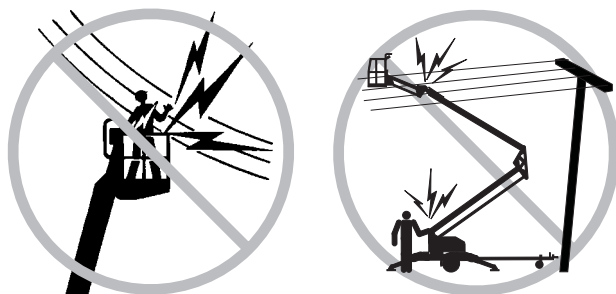

Maintain safe distances from electrical power lines and apparatus in accordance with applicable governmental regulations and the following chart.

Voltage Phase to Phase	Minimum Safe Approach Distance	
	Feet	Meters
0 to 300V	Avoid Contact	
300V to 50KV	10	3.05
50KV to 200KV	15	4.60
200KV to 350KV	20	6.10
350KV to 500KV	25	7.62
500KV to 750KV	35	10.67
750KV to 1000KV	45	13.72

Allow for platform movement, electrical line sway or sag and beware of strong or gusty winds.

Keep away from the machine if it contacts energized power lines. Personnel on the ground or in the platform must not touch or operate the machine until energized power lines are shut off.

Do not operate the machine during lightning or storms.

Do not use the machine as a ground for welding.

Do not operate an AC powered machine or a DC battery charger unless using a 3-wire grounded extension cord connected to a grounded AC circuit. Do not alter or disable 3-wire grounded plugs.

Tip-over Hazards

Occupants, equipment and materials shall not exceed the maximum platform capacity.

Maximum capacity - without optional platform rotate

ANSI/CSA models - 2 occupants	500 lbs	227 kg
CE models - 2 occupants	440 lbs	200 kg

Maximum capacity - with optional platform rotate

ANSI/CSA models - 2 occupants	460 lbs	209 kg
CE models - 1 occupant	400 lbs	181 kg

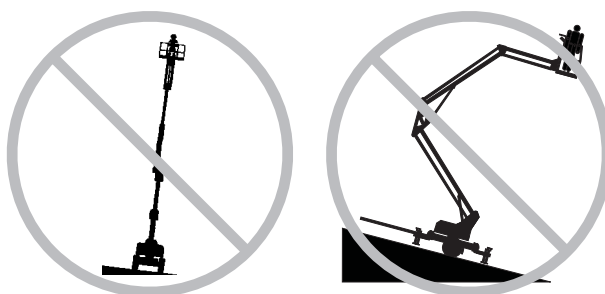

Do not raise the boom unless the machine is level. Do not set the machine up on a surface where it cannot be leveled using only the outriggers.

Do not raise the boom unless all four outriggers are lowered, the footpads are in firm contact with the ground and the machine is level.

Do not set the machine up unless it is on a firm surface. Avoid drop-offs, holes, unstable or slippery surfaces and other possible hazardous conditions.

SAFETY RULES

Do not move the machine when the boom is raised.

Do not adjust or stow the outriggers when the boom is raised.

Do not depend on the tilt alarm as a level indicator. The tilt alarm sounds only when the machine is on a severe slope.

When the tilt alarm sounds, immediately lower the boom and adjust the outriggers to level the machine.

Do not alter or disable the limit switches.



Do not operate the machine in strong or gusty winds. Do not increase the surface area of the platform or the load. Increasing the area exposed to the wind will decrease machine stability.

Do not alter or disable machine components that in any way affect safety and stability.

Do not replace items critical to machine stability with items of different weight or specification.

Do not modify or alter an aerial work platform without prior written permission from the manufacturer. Mounting attachments for holding tools or other materials onto the platform, toeboards or guard rail system can increase the weight in the platform and the surface area of the platform or the load.

Do not transport tools and materials unless they are evenly distributed and can be safely handled by person(s) in the platform.

Do not place ladders or scaffolds in the platform or against any part of this machine.

Do not use the machine on a moving or mobile surface or vehicle.

Be sure all tires are properly inflated and in good condition and lug nuts are properly tightened.

Do not use the platform as a crane.

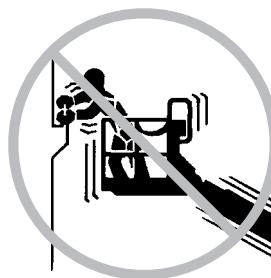

Do not place loads outside the platform perimeter.

Do not place or attach overhanging loads to any part of the platform.

**Maximum allowable
manual force, CE 400 N**

Do not push off or pull toward any object outside of the platform.

Do not push the machine or other objects with the boom.

Do not use the platform controls to free a platform that is caught, snagged or otherwise prevented from normal motion by an adjacent structure. All personnel must be removed from the platform before attempting to free the platform using the ground controls.

DC models: Do not use batteries that weigh less than the original equipment. Four batteries are used as counterweight and are critical to machine stability. Each battery must weigh 65 pounds / 29.5 kg.

Do not contact adjacent structures with the boom.

Do not tie the boom or platform to adjacent structures.

SAFETY RULES

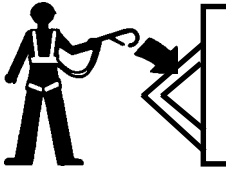
Fall Hazards

Occupants must wear a safety belt or harness and comply with applicable governmental regulations. Attach the lanyard to the anchor provided in the platform.

Do not sit, stand or climb on the platform guard rails. Maintain a firm footing on the platform floor at all times.

Do not climb down from the platform when raised.

Keep the platform floor clear of debris.

Lower the platform entry mid-rail or close the entry gate before operating.

Collision Hazards

The machine must be on a level surface or secured before releasing the parking brake.

Do not attempt to manually move a machine unless it is on a firm, level surface. Use the parking brake to control the speed of the machine while pushing it.

Check the work area for overhead obstructions or other possible hazards.



Be aware of crushing hazards when grasping the platform guard rail.

Do not lower the boom unless the area below is clear of personnel and obstructions.

Be aware of boom position when rotating the turntable.

Operators must comply with employer, job site and governmental rules regarding use of personal protective equipment.

Do not operate a boom in the path of any crane unless the controls of the crane have been locked out and/or precautions have been taken to prevent any potential collision.

No stunt driving or horseplay while operating the machine.

Explosion and Fire Hazards

Do not operate the machine in hazardous locations or locations where potentially flammable or explosive gases or particles may be present.

Component Damage Hazards

Do not use the machine as a ground for welding.

Do not fully lower the booms unless the booms are aligned with the tongue. The primary boom must be lowered into the chassis cradle.

SAFETY RULES

Damaged Machine Hazards

Do not use a damaged or malfunctioning machine.

Conduct a thorough pre-operation inspection of the machine and test all functions before each work shift. Immediately tag and remove from service a damaged or malfunctioning machine.

Be sure all maintenance has been performed as specified in this manual and the appropriate service manual.

Be sure all decals are in place and legible.

Be sure the operator's, safety and responsibilities manuals are complete, legible and in the storage container located on the platform.

Bodily Injury Hazard

Do not operate the machine with a hydraulic oil or air leak. An air leak or hydraulic leak can penetrate and/or burn skin.

Improper contact with components under any cover will cause serious injury. Only trained maintenance personnel should access compartments. Access by the operator is only advised when performing a pre-operation inspection. All compartments must remain closed and secured during operation.

Towing Hazards

Read, understand and obey all of your tow vehicle manufacturer's recommendations, warnings and instructions before towing this machine.

Make sure your tow vehicle is properly maintained and capable of towing this machine.

Be sure the hitch is properly and securely attached to your tow vehicle.

Do not overload your tow vehicle. Observe the manufacturer's Gross Vehicle Weight Rating (GVWR).

Be sure all lights, mirrors and hitch components conform to federal and local regulations.

Be sure that all driving lights are operational.

Be sure the tires are properly inflated.

Do not tow the machine unless the boom is lowered into both cradles and the hold-down latches are securely locked in place. There is a mast cradle on the chassis and a mid-pivot cradle on the tongue of the machine.

Do not load cargo on the machine. The TZ is not designed to carry any extra cargo.

Be sure the safety chains (if required) are securely attached to the tow vehicle. Cross the chains under the hitch. This will create a cradle to catch the tongue of the trailer if it becomes disconnected from the tow vehicle.

Do not tow the machine on public roads unless it meets all governmental regulations for towing.

Do not exceed 60 mph / 97 km/h. Obey all local and national towing speed laws.

Be sure to chock the wheels of the trailer when parking on a hill.

SAFETY RULES

Battery Safety - DC Models**Burn Hazards**

Batteries contain acid. Always wear protective clothing and eyewear when working with batteries.

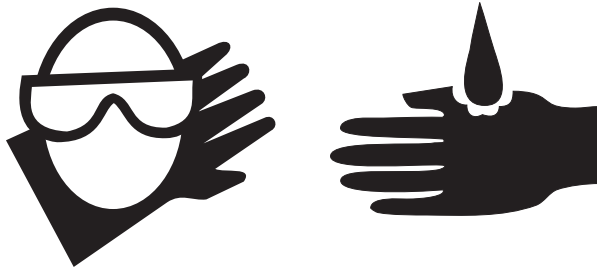

Avoid spilling or contacting battery acid. Neutralize battery acid spills with baking soda and water.

Explosion Hazards

Keep sparks, flames and lighted tobacco away from batteries. Batteries emit an explosive gas.

The covers should be open during the entire charging cycle.

Do not contact the battery terminals or the cable clamps with tools that may cause sparks.

Component Damage Hazards

Do not use any battery charger greater than 24V to charge the batteries.

Do not expose the batteries or the charger to water or rain.

Electrocution Hazards

Connect the battery charger to a grounded, AC 3-wire electrical outlet only.



Inspect daily for damaged cord, cables and wires. Replace damaged items before operating.

Avoid electrical shock from contact with battery terminals. Remove all rings, watches and other jewelry.

Tip-over Hazard

Do not use batteries that weigh less than the original equipment. Four batteries are used as counterweight and are critical to machine stability. Each battery must weigh 65 pounds / 29.5 kg.

Lifting Hazard

Use the appropriate number of people and proper lifting techniques when lifting batteries.

SAFETY RULES

Decal Legend

Genie product decals use symbols, color coding and signal words to identify the following:



Safety alert symbol—used to alert personnel to potential personal injury hazards. Obey all safety messages that follow this symbol to avoid possible injury or death.



Red—used to indicate the presence of an imminently hazardous situation which, if not avoided, will result in death or serious injury.



Orange—used to indicate the presence of a potentially hazardous situation which, if not avoided, could result in death or serious injury.



Yellow with safety alert symbol—used to indicate the presence of a potentially hazardous situation which, if not avoided, may cause minor or moderate injury.



Yellow without safety alert symbol—used to indicate the presence of a potentially hazardous situation which, if not avoided, may result in property damage.



Green—used to indicate operation or maintenance information.

Controls

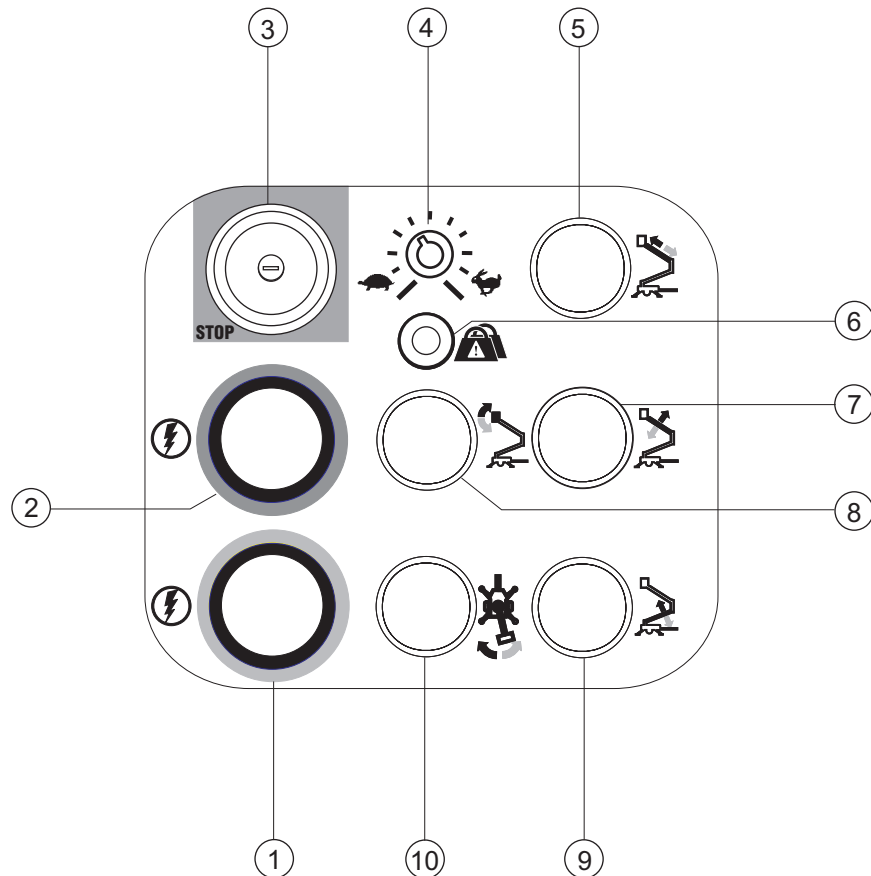

Platform Control Panel

- | | |
|---|---|
| <p>1 Function enable button for:
 Platform down
 Primary boom down
 Primary boom retract
 Secondary boom down
 Turntable rotate right</p> | <p>3 Red Emergency Stop button</p> |
| <p>2 Function enable button for:
 Platform up
 Primary boom up
 Primary boom extend
 Secondary boom up
 Turntable rotate left</p> | <p>4 Boom function speed controller</p> <p>5 Primary boom extend/retract button</p> <p>6 Platform overload indicator light (if equipped)</p> <p>7 Primary boom up/down button</p> <p>8 Platform level button</p> <p>9 Secondary boom up/down button</p> <p>10 Turntable rotate button</p> |

CONTROLS

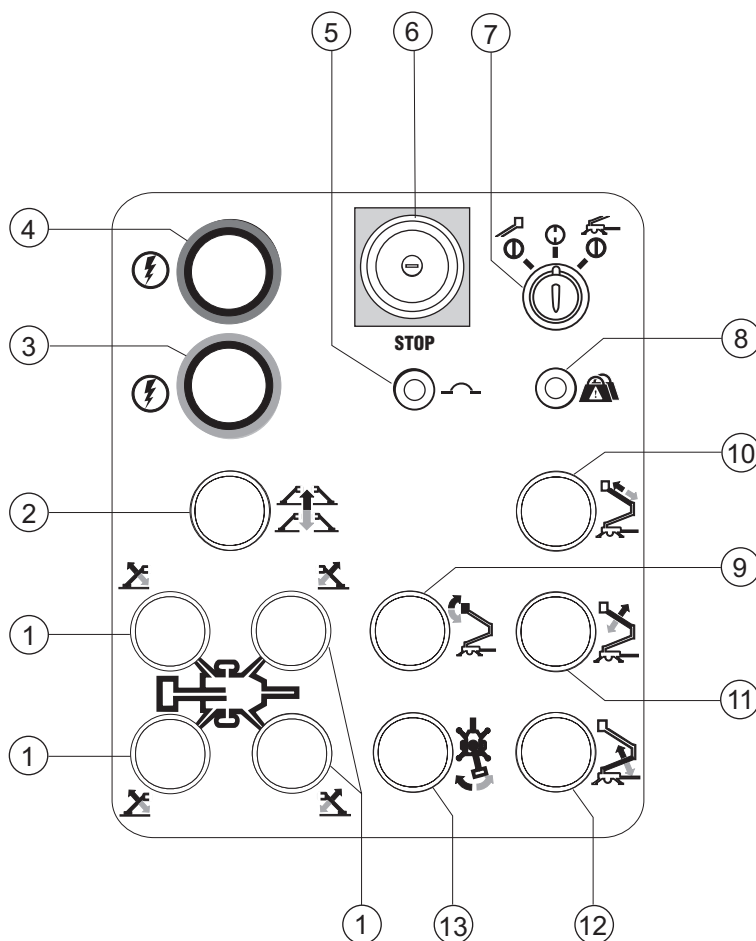

Ground Control Panel

- | | | |
|--|---|--|
| <p>1 Outrigger raise/lower button (individual outrigger)</p> <p>2 Outrigger auto level button</p> <p>3 Function enable button for:
Platform down
Primary boom down
Primary boom retract
Secondary boom down
Turntable rotate right
Outrigger lower</p> | <p>4 Function enable button for:
Platform up
Primary boom up
Primary boom extend
Secondary boom up
Turntable rotate left
Outrigger raise</p> <p>5 15 amp breaker for controls circuits</p> <p>6 Red Emergency Stop button</p> <p>7 Key switch for ground/off/platform selection</p> | <p>8 Platform overload indicator light (if equipped)</p> <p>9 Platform level button</p> <p>10 Primary boom extend/retract button</p> <p>11 Primary boom up/down button</p> <p>12 Secondary boom up/down button</p> <p>13 Turntable rotate button</p> |
|--|---|--|

Pre-operation Inspection



Do Not Operate Unless:

- You learn and practice the principles of safe machine operation contained in this operator's manual.

1 Avoid hazardous situations.

2 Always perform a pre-operation inspection.

Know and understand the pre-operation inspection before going on to the next section.

3 Always perform function tests prior to use.

4 Inspect the workplace.

5 Only use the machine as it was intended.

Fundamentals

It is the responsibility of the operator to perform a pre-operation inspection and routine maintenance.

The pre-operation inspection is a visual inspection performed by the operator prior to each work shift. The inspection is designed to discover if anything is apparently wrong with a machine before the operator performs the function tests.

The pre-operation inspection also serves to determine if routine maintenance procedures are required. Only routine maintenance items specified in this manual may be performed by the operator.

Refer to the list on the next page and check each of the items.

If damage or any unauthorized variation from factory delivered condition is discovered, the machine must be tagged and removed from service.

Repairs to the machine may only be made by a qualified service technician, according to the manufacturer's specifications. After repairs are completed, the operator must perform a pre-operation inspection again before going on to the function tests.

Scheduled maintenance inspections shall be performed by qualified service technicians, according to the manufacturer's specifications and the requirements listed in the responsibilities manual.

PRE-OPERATION INSPECTION

Pre-operation Inspection

- Be sure that the operator's, safety and responsibilities manuals are complete, legible and in the storage container located on the platform.
- Be sure that all decals are legible and in place. See Decals section.
- Check for hydraulic oil leaks and proper oil level. Add oil if needed. See Maintenance section.
- DC models: Check for battery fluid leaks and proper fluid level. Add distilled water if needed. See Maintenance section.
- Check for proper tire pressure and lug nut torque. Add air to tires if needed. See Maintenance section.

Check the following components or areas for damage, improperly installed or missing parts and unauthorized modifications:

- Electrical components, wiring and electrical cables
- Hydraulic power unit, reservoir, hoses, fittings, cylinders and manifolds
- Boom components and wear pads
- Tires and wheels
- Trailer lights and reflectors
- Parking brake components
- Outriggers and foot pads
- Limit switch and alarms
- Nuts, bolts and other fasteners
- Platform entry mid-rail/gate
- Surge brake components
- Safety chains (if required)
- Light and brake cables

- Mechanical brake components (if equipped)
- Axle components
- Beacon and alarms (if equipped)

Check entire machine for:

- Cracks in welds or structural components
- Dents or damage to machine
- Be sure that all structural and other critical components are present and all associated fasteners and pins are in place and properly tightened.
- Be sure that the batteries are in place and properly connected.
- Models equipped with hydraulic surge brake systems:
Check the hydraulic oil level in the surge brake.
Check for leaks.
- After you complete your inspection, be sure that all compartment covers are in place and latched.

Maintenance



Observe and Obey:

- ☑ Only routine maintenance items specified in this manual shall be performed by the operator.
- ☑ Scheduled maintenance inspections shall be completed by qualified service technicians, according to the manufacturer's specifications and the requirements specified in the responsibilities manual.

Maintenance Symbols Legend

NOTICE

The following symbols have been used in this manual to help communicate the intent of the instructions. When one or more of the symbols appear at the beginning of a maintenance procedure, it conveys the meaning below.



Indicates that tools will be required to perform this procedure.



Indicates that new parts will be required to perform this procedure.

Check the Batteries - DC Models



Proper battery condition is essential to good machine performance and operational safety. Improper fluid levels or damaged cables and connections can result in component damage and hazardous conditions.

NOTICE

This procedure does not need to be performed on machines with sealed or maintenance-free batteries

⚠ WARNING

Electrocution hazard. Contact with hot or live circuits could result in death or serious injury. Remove all rings, watches and other jewelry.

⚠ WARNING

Bodily injury hazard. Batteries contain acid. Avoid spilling or contacting battery acid. Neutralize battery acid spills with baking soda and water.

- 1 Put on protective clothing and eye wear.
- 2 Be sure that the battery cable connections are tight and free of corrosion.
- 3 Be sure that the battery hold-down brackets are secure.
- 4 Remove the battery vent caps.
- 5 Check the battery acid level. If needed, replenish with distilled water to the bottom of the battery fill tube. Do not overfill.
- 6 Install the vent caps.

MAINTENANCE

Check the Tires and Wheels



WARNING Bodily injury hazard. An over-inflated tire can explode and may cause death or serious injury.

WARNING Collision hazard. An excessively worn tire can cause poor handling and continued use could result in tire failure.

WARNING Tip-over hazard. Do not use temporary flat tire repair products.

Maintaining the tires and wheels in good condition is essential to safe operation and good performance. Tire and/or wheel failure could result in a machine tip-over. Component damage may also result if problems are not discovered and repaired in a timely fashion.

- 1 Check the tire surface and sidewalls for cuts, cracks, punctures and uneven or excessive tread wear.
- ⦿ Result: Replace the tire if uneven or excessive tread wear is found.

NOTICE Tires and wheels must be replaced with tires and wheels of the specifications listed.

- 2 Check each wheel for damage, bends and cracks.
- ⦿ Result: Replace the wheel if any damage is found.
- 3 Check each tire with an air pressure gauge and add air as needed.
- 4 Check the torque of each lug nut.

Tires and wheels - ANSI & CSA

Tire size	ST205/75 R14 Load Range C	
-----------	------------------------------	--

Lug nut torque (dry)	100 ft-lbs	135 Nm
----------------------	------------	--------

Tire pressure (cold)	50 psi	3.4 bar
----------------------	--------	---------

Tires and wheels - CE

Tire size	185 R14C 102/100N	
-----------	----------------------	--

Lug nut torque (dry)	66 ft-lbs	90 Nm
----------------------	-----------	-------

Tire pressure (cold)	65 psi	4.5 bar
----------------------	--------	---------

MAINTENANCE

Check the Hydraulic Oil Level

Maintaining the hydraulic oil at the proper level is essential to machine operation. Improper hydraulic oil levels can damage hydraulic components. Daily checks allow the inspector to identify changes in oil level that might indicate the presence of hydraulic system problems.

- 1 Be sure the boom is in the stowed position and the outriggers are raised.
 - 2 Remove the cap from the hydraulic tank and check the dipstick.
- ⦿ Result: The hydraulic oil level should be at the mark on the dipstick.

Hydraulic oil specifications

Hydraulic oil type	Chevron Rykon Premium MV equivalent
--------------------	--

Scheduled Maintenance

Maintenance performed quarterly, annually, semi-annually and every two years must be completed by a person trained and qualified to perform maintenance on this machine according to the procedures found in the service manual for this machine.

Machines that have been out of service for more than three months must receive the quarterly inspection before they are put back into service.

Function Tests



Do Not Operate Unless:

- You learn and practice the principles of safe machine operation contained in this operator's manual.
 - 1 Avoid hazardous situations.
 - 2 Always perform a pre-operation inspection.
 - 3 Always perform function tests prior to use.**
- Know and understand the function tests before going on to the next section.**
 - 4 Inspect the workplace.
 - 5 Only use the machine as it was intended.

Fundamentals

The function tests are designed to discover any malfunctions before the machine is put into service. The operator must follow the step-by-step instructions to test all machine functions.

A malfunctioning machine must never be used. If malfunctions are discovered, the machine must be tagged and removed from service. Repairs to the machine may only be made by a qualified service technician, according to the manufacturer's specifications.

After repairs are completed, the operator must perform a pre-operation inspection and function tests again before putting the machine into service.

FUNCTION TESTS

Setup

- 1 Position the machine below the desired work area.
- 2 Set the parking brake.
- 3 Disconnect the trailer lights, safety chains and brake cables from the vehicle.
- 4 Open the latch on the ball coupler.
- 5 Pull the jack release handle and rotate the tongue jack to the lifting position.
- 6 Raise the tongue by turning the jack handle.
- 7 Be sure the boom hold-down latches are unlatched.
- 8 Connect to the appropriate power source:
DC models: Connect the battery packs.
AC models: Connect to a grounded 15A AC power supply.
- 9 AC models: Check the power panel at the end of the chassis behind the platform.

- ⊙ **Result:** The CV light should be on. The CC and SHORT lights should be off.

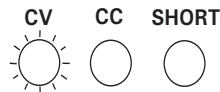
**At the Ground Controls**

- 10 Insert the key and turn to ground control.
- 11 Pull out the red Emergency Stop button to the on position.
- 12 **Auto level:** Push and hold the yellow function enable button. Push and hold the auto level button. The outriggers will lower and adjust to level the machine and raise the wheels off the ground. Level the machine using only the outriggers. Use the bubble level to make sure the machine is level.

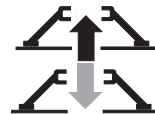

- Manual level:** Push and hold the yellow function enable button. Push and hold each outrigger button to lower the outriggers. Adjust the outriggers to level the machine and raise the wheels off the ground. Level the machine using only the outriggers. Use the bubble level to make sure the machine is level.

- 13 Be sure the wheels on the tongue jack are not touching the ground.

Note: If the wheels on the tongue jack are touching the ground, crank the tongue jack up until the wheels are no longer on the ground.

FUNCTION TESTS

Test the Tilt Sensor

- 14 Raise the boom 2 feet / 60 cm.
- 15 Turn the key switch to platform control.
- 16 Locate the tilt sensor next to the forklift pocket on the side of the machine opposite the ground controls.
- 17 Press down one side of the tilt sensor.

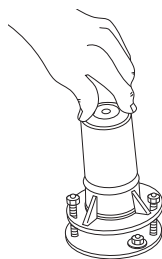

- ⦿ Result: The alarm should sound.

Test Emergency Stop

- 18 Push in the red Emergency Stop button to the off position.
- ⦿ Result: All ground and platform control functions should not operate.
- 19 Pull out the red Emergency Stop button to the on position.

Test Boom Functions and Function Enable

- 20 Do not push a function enable button. Attempt to activate each boom function button.
- ⦿ Result: All boom functions should not operate.
- 21 Push and hold the blue function enable button. Activate each boom function button.
- ⦿ Result: Primary boom up, primary boom extend, secondary boom up, platform level up and turntable rotate right should all function.
- 22 Push and hold the yellow function enable button. Activate each boom function button.
- ⦿ Result: Primary boom down, primary boom retract, secondary boom down, platform level down and turntable rotate left should all function.

Test Outrigger Interlock

- 23 Lower the boom into the stowed position.
- 24 Push and hold the blue function enable button. Push and hold one outrigger button and raise the outrigger off the ground.
- 25 Push and hold the blue function enable button and activate each boom function.
- ⦿ Result: All boom functions should not operate.
- 26 Use the leveling buttons to lower the outrigger.
- 27 Repeat this procedure for each outrigger.
- 28 Use the function enable buttons and the auto level button or the outrigger leveling buttons to make sure the machine is level.
- 29 Raise the platform approximately 2 feet / 60 cm.
- 30 Push and hold the blue function enable button and attempt to raise each outrigger off the ground.
- ⦿ Result: The outriggers should not raise.

FUNCTION TESTS

Test Manual Operation of Functions

31 Raise the primary boom approximately 2 feet / 60 cm.

32 Open the manifold cover on the ground controls side of the machine.

33 Locate the primary boom up/down valve.

34 Push the thumbscrew in and turn to release.

☉ Result: The thumbscrew should move easily.

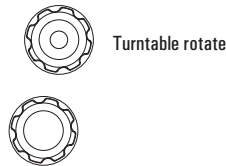

35 Pull the thumbscrew all the way out and turn.

☉ Result: The thumbscrew should move easily and stay in position.

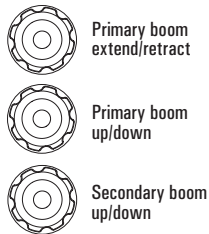

36 Turn the thumbscrew and release.

37 Push the thumbscrew all the way in and turn.

☉ Result: The thumbscrew should move easily and stay in position.

38 Operate the hand pump on top of the power unit cover.

☉ Result: The primary boom should lower.

39 Turn the thumbscrew and release.

40 To reset the valve, push the thumbscrew halfway in and turn.

☉ Result: The thumbscrew should move easily and stay in position.

41 Test the remaining valves.

☉ Result: Each valve thumbscrew should move easily and stay in position.

Note: Make sure to properly reset each valve. The machine will not operate unless the valves are reset.

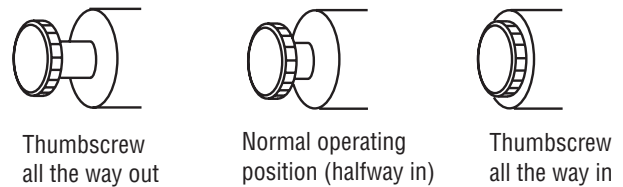

FUNCTION TESTS

At the Platform Controls

- 42 Turn the key switch to platform control.
- 43 Pull out the platform red Emergency Stop button to the on position.

Test Emergency Stop

- 44 Push in the platform red Emergency Stop button to the off position.
- ⊙ Result: All platform control functions should not operate.
- 45 Pull out the platform red Emergency Stop button to the on position.

Test Boom Functions and Function Enable

- 46 Do not push a function enable button. Attempt to activate each boom function button.
- ⊙ Result: All boom functions should not operate.
- 47 Push and hold the blue function enable button. Activate each boom function button.
- ⊙ Result: Primary boom up, primary boom extend, secondary boom up, platform level up and turntable rotate right should all function.
- 48 Push and hold the yellow function enable button. Activate each boom function button.
- ⊙ Result: Primary boom down, primary boom retract, secondary boom down, platform level down and turntable rotate left should all function.

Workplace Inspection



Do Not Operate Unless:

- You learn and practice the principles of safe machine operation contained in this operator's manual.

- 1 Avoid hazardous situations.
- 2 Always perform a pre-operation inspection.
- 3 Always perform function tests prior to use.

4 Inspect the workplace.

Know and understand the workplace inspection before going on to the next section.

- 5 Only use the machine as it was intended.

Fundamentals

The workplace inspection helps the operator determine if the workplace is suitable for safe machine operation. It should be performed by the operator prior to moving the machine to the workplace.

It is the operator's responsibility to read and remember the workplace hazards, then watch for and avoid them while moving, setting up and operating the machine.

Workplace Inspection

Be aware of and avoid the following hazardous situations:

- drop-offs or holes
- bumps, floor obstructions or debris
- slopes that exceed the machine's leveling capability
- unstable or slippery surfaces
- overhead obstructions and high voltage conductors
- hazardous locations
- inadequate surface support to withstand all load forces imposed by the machine
- wind and weather conditions
- the presence of unauthorized personnel
- other possible unsafe conditions

Operating Instructions



Do Not Operate Unless:

- You learn and practice the principles of safe machine operation contained in this operator's manual.
 - 1 Avoid hazardous situations.
 - 2 Always perform a pre-operation inspection.
 - 3 Always perform function tests prior to use.
 - 4 Inspect the workplace.
- 5 Only use the machine as it was intended.**

Fundamentals

The Operating Instructions section provides instructions for each aspect of machine operation. It is the operator's responsibility to follow all the safety rules and instructions in the operator's, safety and responsibilities manuals.

Using the machine for anything other than lifting personnel, along with their tools and materials, to an aerial work site is unsafe and dangerous.

Only trained and authorized personnel should be permitted to operate a machine. If more than one operator is expected to use a machine at different times in the same work shift, they must all be qualified operators and are all expected to follow all safety rules and instructions in the operator's, safety and responsibilities manuals. That means every new operator should perform a pre-operation inspection, function tests and a workplace inspection before using the machine.

Emergency Stop

Push in the red Emergency Stop button to the off position at the ground or platform controls to stop all machine functions.

Repair any function that operates when the red Emergency Stop button is pushed in.

Selecting and operating the ground controls will override the platform red Emergency Stop button.

Setup

Make sure the machine is properly set up and tested. See Function Tests section.

OPERATING INSTRUCTIONS

Operation from Ground

- 1 Turn the key switch to ground control.
- 2 Pull out the red Emergency Stop button to the on position.
- 3 Press and hold the yellow function enable button. Press and hold the auto level button or the individual outrigger buttons to lower the outriggers and level the machine.
- 4 Check the bubble level to make sure the machine is level.

**To Position Platform**

- 1 Push and hold the appropriate function enable button.
- 2 Push and hold the boom function button according to the markings on the control panel.

Operation from Platform

- 1 Turn the key switch to platform control.
- 2 Pull out both ground and platform red Emergency Stop buttons to the on position.

To Position Platform

- 1 Push and hold the appropriate function enable button.
- 2 Push and hold the boom function button according to the markings on the control panel.
- 3 If equipped: Rotate the platform by turning the hand crank in either a clockwise or counterclockwise direction.

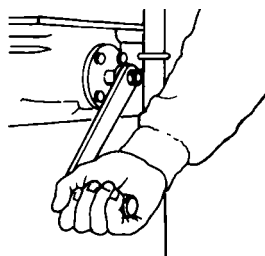
**Manual Operation of Functions**

All boom functions can be operated with the hand pump located on top of the power unit cover.

Manifold valves are located under the manifold cover on the ground controls side of the machine.

There are three locked positions on each manifold valve. The center locked position is for normal machine operation.

- 1 Locate the valve for the desired function. Push the thumbscrew and turn to release.
- 2 Set the valve to perform the desired action. Make sure to turn the thumbscrew until it locks in place.

Turntable rotate

Clockwise: Pull the thumbscrew all the way out and turn.

Counterclockwise: Push the thumbscrew all the way in and turn.



Turntable rotate

**Primary boom**

Retract: Push the thumbscrew all the way in and turn.

Extend: Pull the thumbscrew all the way out and turn.

Down: Push the thumbscrew all the way in and turn.

Up: Pull the thumbscrew all the way out and turn.



Primary boom extend/retract



Primary boom up/down



Secondary boom up/down

Secondary boom

Down: Push the thumbscrew all the way in and turn.

Up: Pull the thumbscrew all the way out and turn.

- 3 Operate the hand pump.

OPERATING INSTRUCTIONS

- 4 Turn the thumbscrew to release.
- 5 Push the thumbscrew halfway in and turn clockwise to lock into position for normal machine operation.

Note: The machine will not operate unless the valves are properly reset.

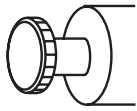

Thumbscrew
all the way out

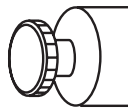

Normal operating
position (halfway in)



Thumbscrew
all the way in

Platform Overload Indicator Light (if equipped)



Light flashing indicates the platform is overloaded and no functions will operate.

Remove weight from the platform until the light goes off.

Fall Protection

Personal fall protection equipment (PFPE) is required when operating this machine.

All PFPE must comply with applicable governmental regulations, and must be inspected and used in accordance with the PFPE manufacturer's instructions.

After Each Use

- 1 Rotate the turntable so that the platform is opposite the tongue of the machine.
- 2 Lower the boom into the mast cradles on the chassis and the tongue.
- 3 Secure the hold-down latches.
- 4 Turn the key switch to the off position and remove the key to secure from unauthorized use.
- 5 DC models: Charge the batteries.

Storage

- 1 Make sure the boom is properly stowed and the hold-down latches are secured.
- 2 Raise and stow the outriggers.
- 3 Select a safe parking location—firm level surface, clear of obstructions and traffic.
- 4 Turn the key switch to the off position and remove the key to secure from unauthorized use.
- 5 Chock the wheels.
- 6 DC models: Charge the batteries.

Moving Machine Without a Tow Vehicle

Do not attempt to manually move a machine unless it is on a firm, level surface. Use the parking brake to control the speed of the machine while pushing it.

OPERATING INSTRUCTIONS

Towing

- 1 Set the parking brake.
- 2 Secure the boom with the hold-down latches.
- 3 Models with Platform Rotate: Rotate the platform until the blue arrows line up on each side of the rotator.
- 4 Raise the tongue by turning the jack handle.
- 5 Position the ball of the transport vehicle directly under the ball coupler.
- 6 Open the latch on the ball coupler.
- 7 Lower the tongue by turning the jack handle.
- 8 Close the latch on the ball coupler.
- 9 Attach the safety chains (if required) and the brake cables to the vehicle. Cross the chains under the hitch.
- 10 Pull the jack release handle and rotate the tongue jack to the stowed position.
- 11 Connect and test the trailer lights.
- 12 Release the parking brake.

Towing Information

Driving a vehicle that is pulling a trailer is different from driving a vehicle alone. Read the following instructions carefully.

Use the checklist on the back cover of this manual before towing and while on the road. Inspect all connections at each stop.

All tires must be properly inflated. Find the recommended cold tire pressures on the tire sidewall or trailer decal. Do not overinflate the tires. Tire pressures go up during driving. Checking the tire pressure when the tires are warm will give you an inaccurate pressure reading.

Increase the distance between your vehicle and the vehicle in front of you to twice the normal following distance when towing a trailer. Allow more following distance in adverse weather.

Slow down for downgrades and shift your transmission into a lower gear.

Slow down for curves, hazardous road conditions, freeway exits, and when driving in adverse weather.

When passing other vehicles, be sure to leave enough room for the extra length of the trailer. You will need to go much farther beyond the passed vehicle before you can return to your lane.

When turning with a trailer, avoid jerky or sudden movements.

Heavy winds, excessive speed, load shifting or passing vehicles can cause the trailer to sway while driving. If this occurs, do not brake, speed up or turn the steering wheel. Turning the steering wheel or applying the brakes can cause the vehicle and trailer to jackknife. Let up on the gas pedal and keep the steering wheel straight.

If the vehicle and/or trailer travels off the paved road, hold the steering wheel firmly and let up on the gas pedal. Do not apply the brakes. Do not turn sharply. Slow down to under 25 mph / 40 km/h. Gradually turn the steering wheel to get back on the road. Proceed with caution when entering traffic.

Backing Up with Trailer (if equipped with hydraulic surge brake)

If your machine is equipped with a hydraulic surge brake, the system must be released before backing up.

Consult the surge brake system manual for specific instructions on each surge brake.

Be sure that the machine is returned to towing or operating configuration when finished.

OPERATING INSTRUCTIONS



Battery and Charger Instructions

Observe and Obey:

- Do not use an external charger or booster battery.
- Charge the battery in a well-ventilated area.
- Use the proper AC input voltage for charging as indicated on the charger.
- Use only a Genie authorized battery and charger.

To Charge Battery

- 1 Be sure the batteries are connected before charging the batteries.
- 2 Open the battery box covers. The covers should remain open for the entire charging cycle.
- 3 Remove the battery vent caps and check the battery acid level. If necessary, add only enough distilled water to cover the plates. Do not overfill prior to the charge cycle.
- 4 Replace the battery vent caps.
- 5 Connect the battery charger to a grounded AC circuit.
- 6 The charger will indicate when the battery is fully charged.
- 7 Check the battery acid level when the charging cycle is complete. Replenish with distilled water to the bottom of the fill tube. Do not overfill.

Dry Battery Filling and Charging Instructions

- 1 Remove the battery vent caps and permanently remove the plastic seal from the battery vent openings.
- 2 Fill each cell with battery acid (electrolyte) until the level is sufficient to cover the plates.

Do not fill to maximum level until the battery charge cycle is complete. Overfilling can cause the battery acid to overflow during charging. Neutralize battery acid spills with baking soda and water.

- 3 Install the battery vent caps.
- 4 Charge the battery.
- 5 Check the battery acid level when the charging cycle is complete. Replenish with distilled water to the bottom of the fill tube. Do not overfill.

Transport and Lifting Instructions



Observe and Obey:

- ☑ The transport vehicle must be parked on a level surface.
- ☑ The transport vehicle must be secured to prevent rolling while the machine is being loaded.
- ☑ Be sure the vehicle capacity, loading surfaces and chains or straps are sufficient to withstand the machine weight. See the serial plate for the machine weight.

Securing to Truck or Trailer for Transit

Fully lower and retract the boom. Make sure the boom and mid-pivot rest securely in the mast cradles.

Securely latch the boom hold-down latches.

Raise all four outriggers to the stowed position.

Always chock the machine wheels in preparation for transport.

Turn the key switch to the off position and remove the key before transporting.

Inspect the entire machine for loose or unsecured items.

Securing the Chassis

Place a block under the tongue.

Place a block on both sides of the axle behind the wheels.

Use the four tie-down points on the chassis for anchoring down to the transport surface.

Use chains or straps of ample load capacity.

Use a minimum of 4 chains to secure the chassis.

Adjust the rigging to prevent damage to the chains.

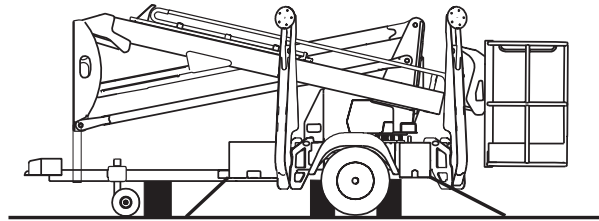

Securing the Boom

Models that are not equipped with a mast cradle at the mid-pivot must perform the following steps:

Support the secondary boom at the mid-pivot with a block placed on the floor of the truck bed, not the tongue of the machine.

Secure the boom with a nylon strap placed over the secondary boom. Do not use excessive downward force when securing the boom section.

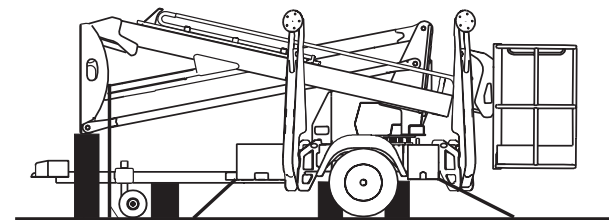

Mid-pivot block
Nylon strap

TRANSPORT AND LIFTING INSTRUCTIONS



Observe and Obey:

- ☑ Only qualified riggers should rig and lift the machine.
- ☑ Be sure the crane capacity, loading surfaces and straps or lines are sufficient to withstand the machine weight. See the serial plate for the machine weight.

Lifting Instructions

Fully lower and retract the boom. Make sure the boom rests in the cradle on the chassis.

Securely latch the boom hold-down latches.

Raise all four outriggers to the stowed position.

Remove all loose items on the machine.

Determine the center of gravity of your machine using the table and the picture on this page.

Attach the rigging only to the designated lifting points on the machine. There are four lifting points on the chassis.

Adjust the rigging to prevent damage to the machine and to keep the machine level.

	X Axis	Y Axis
ANSI & CSA	9.1 in 23.1 cm	9.4 in 23.9 cm
CE	5.2 in 13.2 cm	9.0 in 22.9 cm

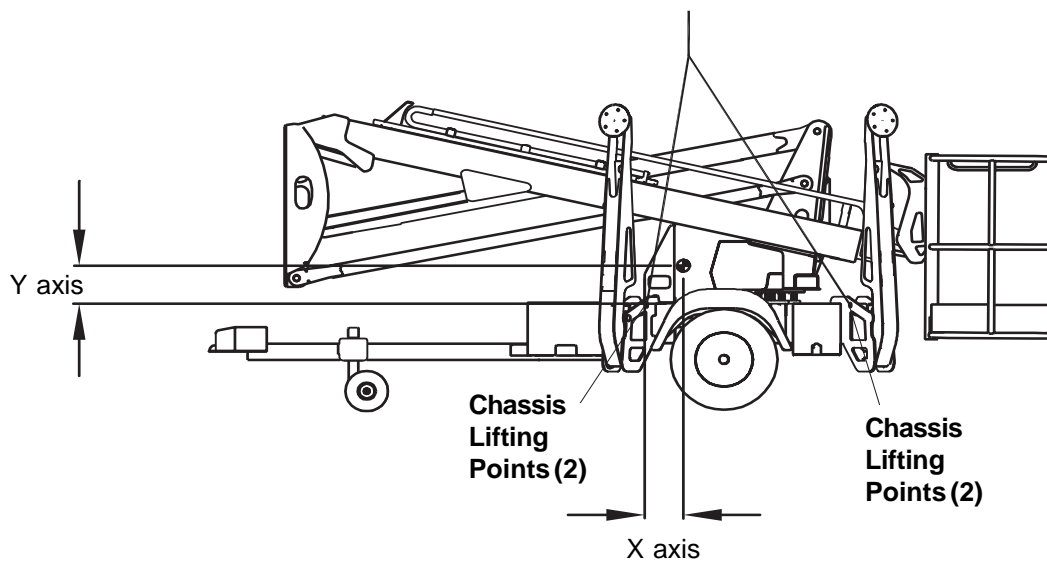

Decals

Inspection for Decals with Words

Determine whether the decals on your machine have words or symbols. Use the appropriate inspection to verify that all decals are legible and in place.

Part No.	Description	Quantity
27564	Danger - Electrocution Hazard	2
28161	Warning - Crushing Hazard	4
28164	Notice - Hazardous Materials	1
28174	Label - Power to Platform, 230V	2
28175	Caution - Compartment Access	1
28176	Notice - Missing Manuals	1
28181	Warning - No Step or Ride	1
28235	Label - Power to Platform, 115V	2
28236	Warning - Failure To Read . . .	1
28373	Label - Forklift Pocket	4
31785	Notice - Battery Charger Operating Instr.	2
37052	Notice - Max Capacity, 500 lbs / 227 kg	1
40434	Label - Lanyard Anchorage	2
43617	Danger - Tip-over (batteries)	2
43658	Label - Power to Battery Charger, 230V	1
44980	Label - Power to Battery Charger, 115V	1
46262	Danger - Battery/Charger Safety	2
48723	Label - Parking Brake	1
52475	Label - Transport Tie-down	4
62707	Warning - Towing Hazard	1
62719	Label - Black Arrow	2
72832	Danger - Tip-over Hazard	4

Part No.	Description	Quantity
72891	Label - Blue Arrow (Platform Rotate)	4
82366	Label - Chevron Rykon	1
82409	Warning - Transport Instructions	1
82423	Danger - General Safety, Platform	1
82477	Notice - Operating Instructions, Platform	1
82478	Notice - Operating Instructions, Ground	1
82479	Danger - General Safety, Ground	1
82491	Notice - Tire Specifications	2
82492	Notice - Battery Connection Diagram	2
82493	Cosmetic - Genie TZ-34/20	2
82505	Danger - Crushing Hazard, Elevated Components	2
82506	Caution - Foot Crushing Hazard	6
82558	Warning - Skin Injection Hazard	1
82585	Label - Outrigger Load	2
82663	Label - Wheel Load	2
82674	Notice - Max Capacity, 460 lbs / 209 kg	1
97557	Ground Control Panel	1
97558	Platform Control Panel	1
97762	Label - Horn (option)	1
97768	Notice - Manifold Valves	1

 Shading indicates decal is hidden from view, i.e. under covers

DECALS

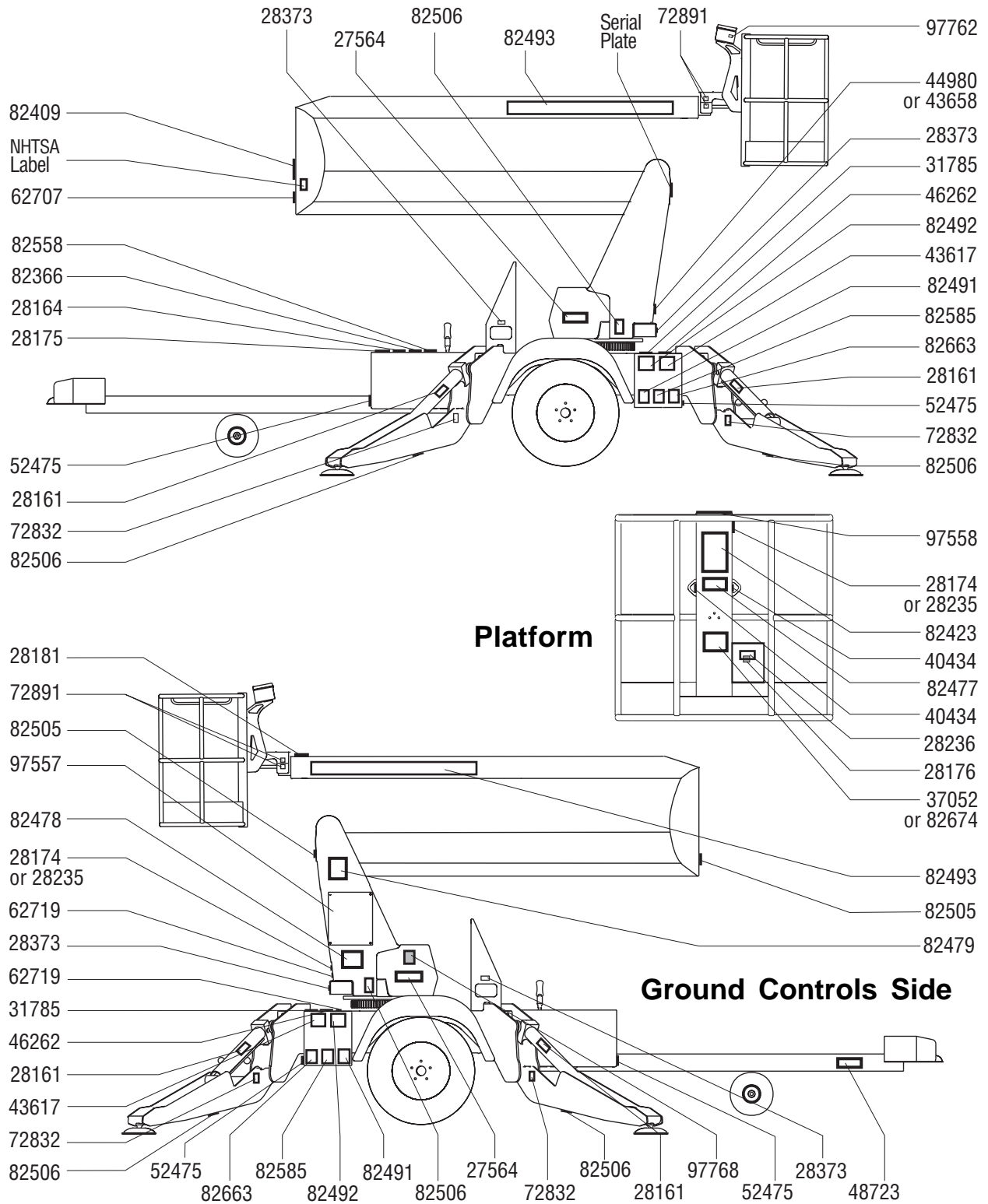

DECALS

Inspection for Decals with Symbols

Determine whether the decals on your machine have words or symbols. Use the appropriate inspection to verify that all decals are legible and in place.

Part No.	Description	Quantity
28174	Label - Power to Platform, 230V	2
28235	Label - Power to Platform, 115V	2
40434	Label - Lanyard Anchorage	2
43658	Label - Power to Battery Charger, 230V	1
44980	Label - Power to Battery Charger, 115V	1
52475	Label - Transport Tie-down	4
62719	Label - Black Arrow	2
72891	Label - Blue Arrow (Platform Rotate)	4
82472	Warning - Crushing Hazard	4
82475	Caution - Foot Crushing Hazard	4
82481	Danger - Battery Safety, DC Models	2
82487	Label - Read The Manual	2
82493	Cosmetic - Genie TZ-34/20	2
82544	Danger - Electrocutation Hazard	3
82560	Warning - Skin Injection Hazard	1
82585	Label - Outrigger Load	2
82612	Danger - Maximum Capacity, 200 kg, ANSI & CSA	1
82614	Danger - Crushing Hazard, Elevated Components	2

Part No.	Description	Quantity
82622	Label - Tire Pressure, ANSI & CSA	2
82658	Danger - Maximum Manual Force, 400 N, CE	1
82659	Label - Parking Brake, CE	1
82661	Label - Parking Brake, ANSI	1
82663	Label - Wheel Load	2
82666	Label - Forklift Pocket	4
82667	Danger - Maximum Capacity, 227 kg, ANSI & CSA	1
82670	Danger - Maximum Capacity, 181 kg, CE	1
82672	Label - Tire Pressure, CE	4
82675	Danger - Maximum Capacity, 209 kg, CE	1
97557	Ground Control Panel	1
97558	Platform Control Panel	1
97563	Label - Circuit Breaker, AC Models	1
97564	Label - AC Power Cord, AC Models	1
97762	Label - Horn (option)	1
97770	Label - Manifold Valves	1



Shading indicates decal is hidden from view, i.e. under covers

DECALS

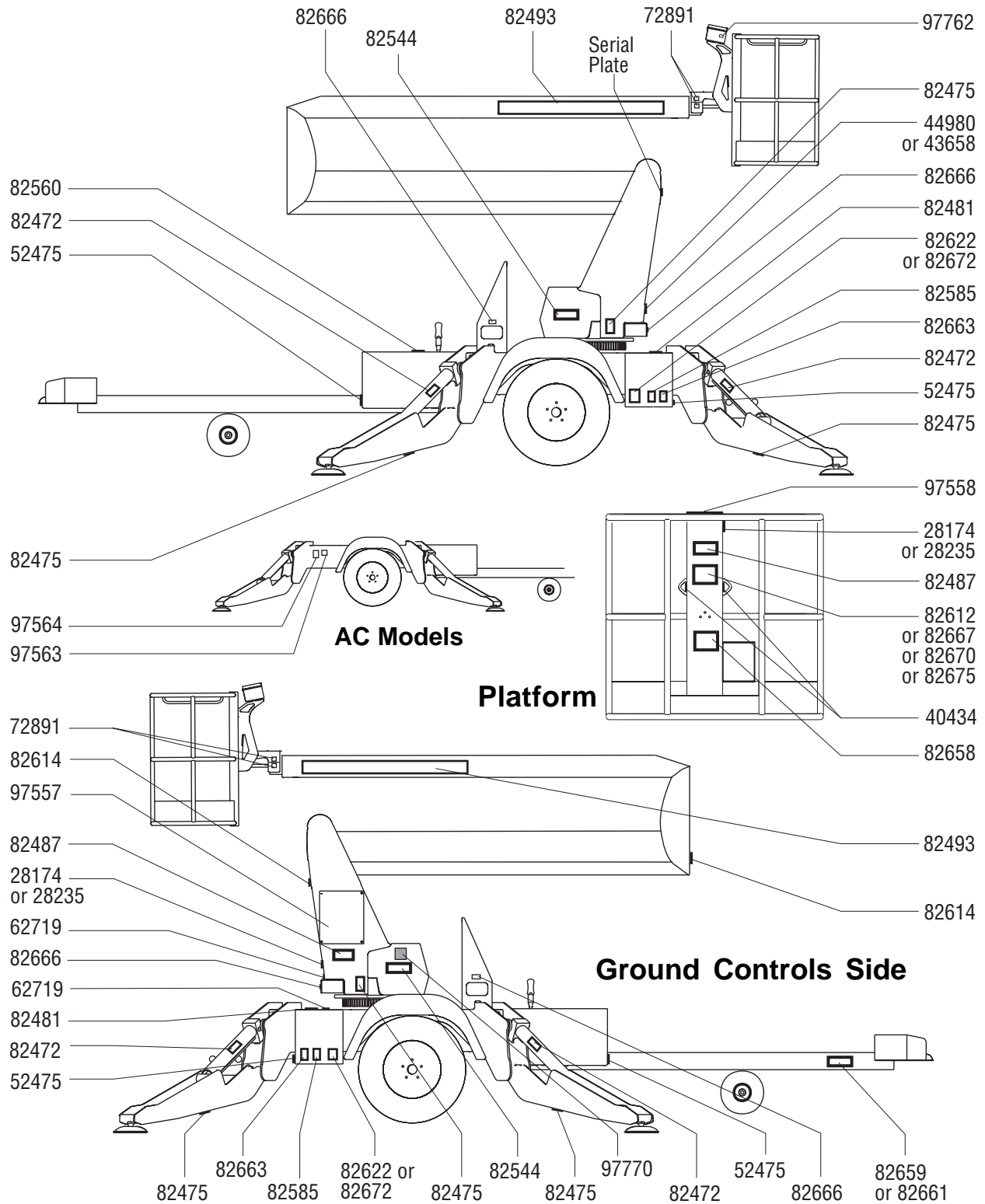

Specifications

Height, working maximum	40 ft	12.2 m
Height, platform maximum	34 ft	10.3 m
Height, stowed maximum	6 ft 5 in	1.96 m
Horizontal working reach maximum from centerline of machine	20 ft	6.1 m
Outrigger footprint (w x l)	10 ft 9 in x 11 ft 10 in	3.3 x 3.6 m
Maximum load capacity without optional platform rotate		
ANSI & CSA	500 lbs	227 kg
CE	440 lbs	200 kg
Maximum load capacity with optional platform rotate		
ANSI & CSA	460 lbs	209 kg
CE - 1 occupant only	400 lbs	181 kg
Width	4 ft 10 in	1.47 m
Length, stowed	16 ft 8 in	5 m
Turntable rotation		359°
Platform rotation (option)		90°
Platform dimensions	44 x 27 in	1.1 m x 68 cm
Platform leveling		self-leveling
Power source	4 GroupT-105 6V 225AH Batteries OR 230V AC/50 Hz	
AC outlet in platform		standard
Tire size, ANSI & CSA models	ST205/75 R14 Load Range C	
Tire size, CE models	185 R14C 102/100N	
Ground clearance	10 in	25.4 cm
Weight (Machine weights vary with option configurations)		See Serial Plate
Maximum towing speed	60 mph	97 km/h

Continuous improvement of our products is a Genie policy. Product specifications are subject to change without notice or obligation.

Maximum tongue weight		
ANSI & CSA	315 lbs	136 kg
CE	165 lbs	75 kg
Airborne noise emissions		70 dB
Maximum sound level at normal operating workstations (A-weighted)		
Hydraulic pressure, maximum (boom functions)	3500 psi	241 bar
System voltage		24V
Floor Loading Information (ANSI & CSA)		
GVW	3150 lbs	1429 kg
Axle load, maximum (GVW only)	2850 lbs	1293 kg
Wheel load, maximum (GVW only)	1425 lbs	646.3 kg
Localized pressure per tire (GVW only)	37 psi	2.6 kg/cm ² 255 kPa
Localized pressure per outrigger (including rated load)	39 psi	2.7 kg/cm ² 268.9 kPa
Outrigger load, maximum (including rated load)	1935 lbs	877 kg
Floor Loading Information (CE)		
GVW	3230 lbs	1469 kg
Axle load, maximum (GVW only)	3065 lbs	1390 kg
Wheel load, maximum (GVW only)	1533 lbs	695 kg
Localized pressure per tire (GVW only)	40 psi	2.81 kg/cm ² 275.7 kPa
Localized pressure per outrigger (including rated load)	39 psi	2.7 kg/cm ² 268.9 kPa
Outrigger load, maximum (including rated load)	1945 lbs	882 kg

Note: Floor loading information is approximate and does not incorporate different option configurations. It should be used only with adequate safety factors.

SPECIFICATIONS

Range of Motion Chart

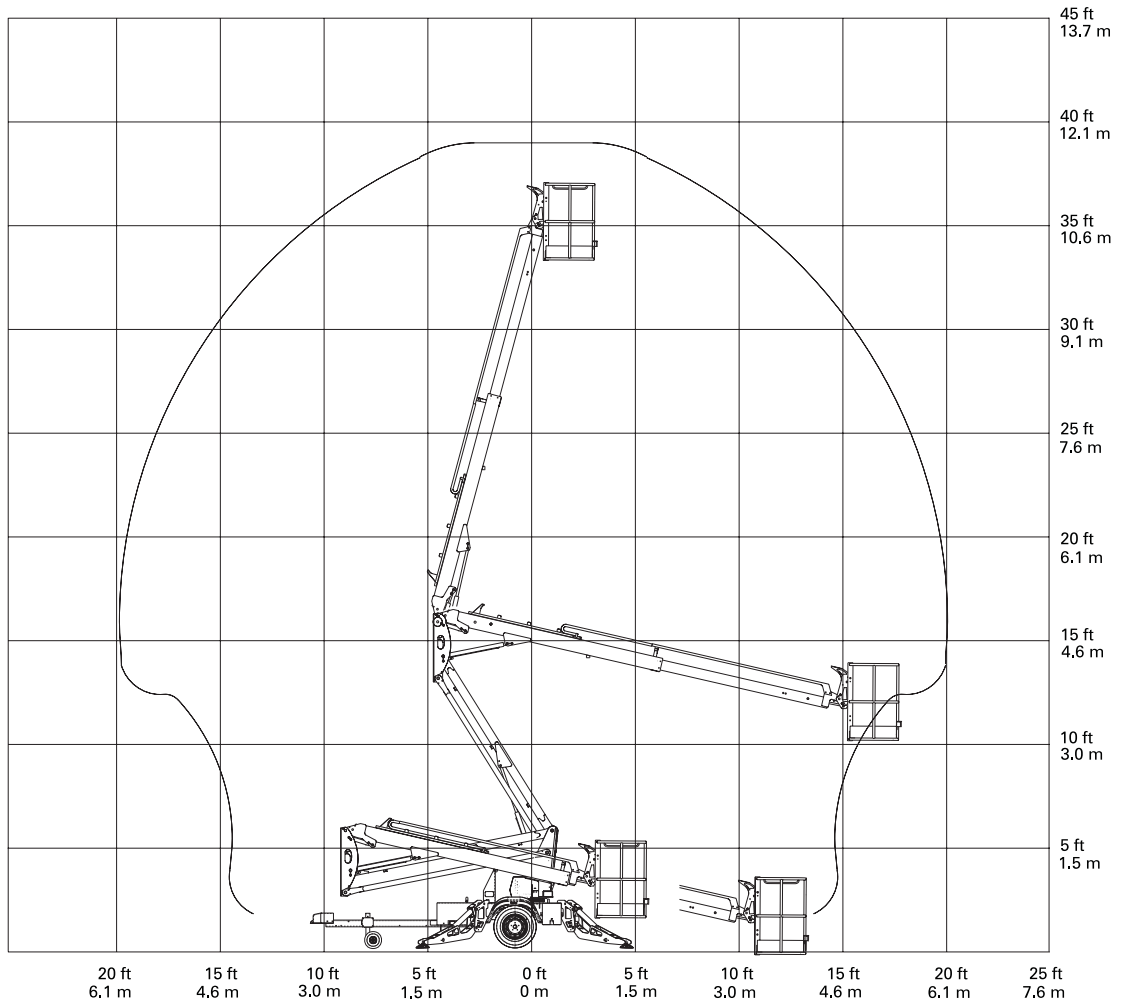

Reporting Safety Defects

Genie Industries
PO Box 97030
Redmond, WA 98073-9730

Reporting Safety Defects

If you believe that your vehicle has a defect which could cause a crash or could cause injury or death, you should immediately inform the National Highway Traffic Safety Administration (NHTSA) in addition to Genie Industries.

If NHTSA receives similar complaints, it may open an investigation, and if it finds that a safety defect exists in a group of vehicles, it may order a recall and remedy campaign. However, NHTSA cannot become involved in any individual problems between you, your dealer or Genie Industries.

To contact NHTSA you may either call the Auto Safety Hotline toll-free at 1-800-424-9393 (366-0123 in Washington DC area) or write to:

NHTSA
U.S. Department of Transportation
400 7th Street SW, (NSA-11)
Washington DC 20590

You can also obtain information about motor vehicle safety from the Hotline.

Towing Checklist

(Use at each stop)

Before Towing

- Boom hold-down latch is securely locked in place
- Towing hitch is properly secured to tow vehicle
- Safety chains (if required) are properly attached and secure (chains are crossed below hitch)
- All lights are connected and working
- Tires are properly inflated

Before Driving

- Fasten safety restraints
- Properly adjust mirrors

On The Road

- Do not exceed 60 mph / 97 km/h. Obey all local and national towing speed laws
- Check connections and tire pressure at each stop
- Slow down for hazardous conditions
- Allow extra distance for following and passing other vehicles

Genie North America

Phone 425.881.1800
Toll Free USA and Canada
800.536.1800
Fax 425.883.3475

Genie Australia Pty Ltd.

Phone +61 7 3375 1660
Fax +61 7 3375 1002

Genie China

Phone +86 21 53852570
Fax +86 21 53852569

Genie Malaysia

Phone +65 98 480 775
Fax +65 67 533 544

Genie Japan

Phone +81 3 3453 6082
Fax +81 3 3453 6083

Genie Korea

Phone +82 25 587 267
Fax +82 25 583 910

Genie Brasil

Phone +55 11 41 665 755
Fax +55 11 41 665 754

Genie Holland

Phone +31 10 220 7911
Fax +31 10 220 6642

Genie Scandinavia

Phone +46 31 3409612
Fax +46 31 3409613

Genie France

Phone +33 (0)2 37 26 09 99
Fax +33 (0)2 37 26 09 98

Genie Iberica

Phone +34 93 579 5042
Fax +34 93 579 5059

Genie Germany

Phone +49 (0)4202 88520
Fax +49 (0)4202 8852-20

Genie U.K.

Phone +44 (0)1476 584333
Fax +44 (0)1476 584334

Genie Mexico City

Phone +52 55 5666 5242
Fax +52 55 5666 3241

Distributed By: