



# *Service Manual*

Serial Number Range

***TML-4000***

from TML01-226

***TML-4000N***

from TML01-226

First Edition

First Printing

Part No. 116472

September 2008

---

# Introduction

---

## Important

Read, understand and obey the safety rules and operating instructions in the appropriate Operator's Manual on your machine before attempting any maintenance procedure.

Basic mechanical, hydraulic and electrical skills are required to perform most procedures. However, several procedures require specialized skills, tools, lifting equipment and a suitable workshop. In these instances, we strongly recommend that maintenance and repair be performed at an authorized Genie dealer service center.

---

## Technical Publications

Genie Industries has endeavored to deliver the highest degree of accuracy possible. However, continuous improvement of our products is a Genie policy. Therefore, product specifications are subject to change without notice.

Readers are encouraged to notify Genie of errors and send in suggestions for improvement. All communications will be carefully considered for future printings of this and all other manuals.

---

## Serial Number Information

Genie Industries offers the following manuals for these models:

Title	Part No.
Genie TML-4000N Operator's Manual, First Edition .....	97600
Genie TML-4000N Parts Manual, First Edition (after serial number TML01-226) .....	116471
Genie TML-4000N Service Manual, First Edition .....	116472

---

## Contact Us:

www.genieindustries.com  
e-mail: techsup@genieind.com

---

Copyright © 2008 by Genie Industries

116472 Rev A September 2008  
First Edition, First Printing

"Genie" is a registered trademark of Genie Industries in the USA and many other countries.  
"TML" is a trademark of Genie Industries.

 Printed on recycled paper

Printed in U.S.A.



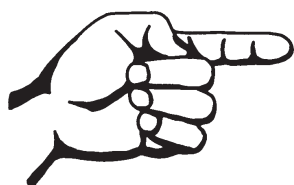

This page intentionally left blank.

# Safety Rules



## Danger

Failure to obey the instructions and safety rules in this manual and the appropriate Operator's Manual on your machine will result in death or serious injury.

Many of the hazards identified in the operator's manual are also safety hazards when maintenance and repair procedures are performed.

## Do Not Perform Maintenance Unless:

- You are trained and qualified to perform maintenance on this machine.
- You read, understand and obey:
  - manufacturer's instructions and safety rules
  - employer's safety rules and worksite regulations
  - applicable governmental regulations
- You have the appropriate tools, lifting equipment and a suitable workshop.

## SAFETY RULES

**Personal Safety**

Any person working on or around a machine must be aware of all known safety hazards. Personal safety and the continued safe operation of the machine should be your top priority.



Read each procedure thoroughly. This manual and the decals on the machine, use signal words to identify the following:



Safety alert symbol—used to alert personnel to potential personal injury hazards. Obey all safety messages that follow this symbol to avoid possible injury or death.



Indicates an imminently hazardous situation which, if not avoided, will result in death or serious injury.



Indicates a potentially hazardous situation which, if not avoided, could result in death or serious injury.



Indicates a potentially hazardous situation which, if not avoided, may cause minor or moderate injury.



Indicates a potentially hazardous situation which, if not avoided, may result in property damage.



Be sure to wear protective eye wear and other protective clothing if the situation warrants it.



Be aware of potential crushing hazards such as moving parts, free swinging or unsecured components when lifting or placing loads. Always wear approved steel-toed shoes.

**Workplace Safety**

Be sure to keep sparks, flames and lighted tobacco away from flammable and combustible materials like battery gases and engine fuels. Always have an approved fire extinguisher within easy reach.



Be sure that all tools and working areas are properly maintained and ready for use. Keep work surfaces clean and free of debris that could get into machine components and cause damage.



Be sure any forklift, overhead crane or other lifting or supporting device is fully capable of supporting and stabilizing the weight to be lifted. Use only chains or straps that are in good condition and of ample capacity.



Be sure that fasteners intended for one time use (i.e., cotter pins and self-locking nuts) are not reused. These components may fail if they are used a second time.



Be sure to properly dispose of old oil or other fluids. Use an approved container. Please be environmentally safe.



Be sure that your workshop or work area is properly ventilated and well lit.

# Table of Contents

---

## Introduction

Important Information .....	<i>ii</i>
How to Read Your Serial Number .....	<i>iii</i>
Parts Stocking List .....	<i>x</i>
How to Order Parts .....	<i>xii</i>
Service Parts Fax Order Form .....	<i>xiii</i>

---

## Section 1

### Safety Rules

General Safety Rules .....	<i>v</i>
----------------------------	----------

---

## Section 2

### Rev

### Specifications

B	Machine Specifications .....	2 - 1
	Performance Specifications .....	2 - 1
	Deutz F3M 1008 Engine .....	2 - 2
	Lombardini LDW 1003/L and Deutz F3M 1008F Engine .....	2 - 3
	Perkins 103-10 Engine .....	2 - 4
	Perkins 403C-11 Engine .....	2 - 5
	Generator Specifications .....	2 - 6
	SAE and Metric Fasteners Torque Charts .....	2 - 7

---

## Section 3

### Rev

### Scheduled Maintenance Procedures

	Introduction .....	3 - 1
	Pre-delivery Preparation Report .....	3 - 3
	Maintenance Inspection Report .....	3 - 5
C	<b>Checklist A Procedures</b>	
A-1	Inspect the Manuals and Decals .....	3 - 6
A-2	Perform Pre-operation Inspection .....	3 - 7
A-3	Perform Function Tests .....	3 - 7
A-4	Perform Engine Maintenance - Perkins Models .....	3 - 7
A-5	Perform Hitch Maintenance .....	3 - 7
A-6	Perform Engine Maintenance - Lombardini and Deutz Models .....	3 - 8
A-7	Perform Hitch Maintenance .....	3 - 8
A-8	Perform 30 Day Service .....	3 - 9



## TABLE OF CONTENTS

<b>Section 3</b>	<b>Rev</b>	<b>Scheduled Maintenance Procedures</b> , continued	
	A-9	Perform Engine Maintenance - Perkins 103-10 Models .....	3 - 9
	A-10	Perform Engine Maintenance - Lombardini and Deutz Models .....	3 - 10
	A-11	Perform Engine Maintenance - Perkins 103-10 Models .....	3 - 10
	A-12	Perform Generator Maintenance .....	3 - 10
	<b>C</b>	<b>Checklist B Procedures</b>	
	B-1	Inspect the Battery .....	3 - 11
	B-2	Inspect the Electrical Wiring .....	3 - 12
	B-3	Inspect the Tires and Wheels (including lug nut torque) .....	3 - 12
	B-4	Perform Engine Maintenance - Lombardini and Deutz Models .....	3 - 13
	B-5	Perform Engine Maintenance - Perkins 403C-11 Models .....	3 - 13
	B-6	Perform Hitch Maintenance .....	3 - 14
	B-7	Perform Engine Maintenance - Perkins 103-10 Models .....	3 - 14
	B-8	Perform Axle Maintenance .....	3 - 14
	<b>B</b>	<b>Checklist C Procedures</b>	
	C-1	Inspect the Cable and Cable Pulleys .....	3 - 15
	C-2	Perform Engine Maintenance - Perkins 403C-11 Models .....	3 - 15
	C-3	Perform Engine Maintenance - Lombardini and Deutz Models .....	3 - 16
	C-4	Perform Engine Maintenance - Perkins 103-10 Models .....	3 - 16
	C-5	Perform Axle Maintenance .....	3 - 16
	<b>B</b>	<b>Checklist D Procedures</b>	
	D-1	Perform Engine Maintenance - Lombardini and Deutz Models .....	3 - 17
	D-2	Perform Engine Maintenance - Perkins 403C-11 Models .....	3 - 17
	D-3	Perform Generator Maintenance - Leroy Somer Models .....	3 - 18
	D-4	Perform Tongue Jack and Outrigger Jack Maintenance .....	3 - 18
	D-5	Perform Axle Maintenance .....	3 - 18
	<b>B</b>	<b>Checklist E Procedure</b>	
	E-1	Perform Engine Maintenance - Lombardini and Deutz Models .....	3 - 19
	E-2	Perform Engine Maintenance - Perkins 403C-11 Models .....	3 - 19
	E-3	Perform Engine Maintenance - Perkins 403C-11 Models .....	3 - 20
	E-4	Perform Generator Maintenance - Marathon Models .....	3 - 20
	E-5	Perform Generator Maintenance - Leroy Somer Models .....	3 - 20



TABLE OF CONTENTS

<b>Section 4</b>	<b>Rev</b>	<b>Repair Procedures</b>	
		Introduction .....	4 - 1
	A	<b>Lighting</b>	
		1-1 Lighting .....	4 - 2
	A	<b>Mast</b>	
		2-1 Mast .....	4 - 4
	A	<b>Chassis</b>	
		3-1 Ground Controls .....	4 - 8
	B	<b>Generator</b>	
		4-1 Generator .....	4 - 11
<hr/>			
<b>Section 5</b>	<b>Rev</b>	<b>Troubleshooting</b>	
		Introduction .....	5 - 1
	A	Theory of Operation .....	5 - 3
	A	Lamp Troubleshooting .....	5 - 4
<hr/>			
<b>Section 6</b>	<b>Rev</b>	<b>Schematics</b>	
	A	Introduction .....	6 - 1
	A	Trailer Lighting Wiring Diagram .....	6 - 2
	A	Electrical Symbols Legend .....	6 - 3
	A	Electrical Schematic - TML4000N (before serial number TML02-522) .....	6 - 4
	A	Electrical Schematic - TML-4000 (before serial number TML02-522) .....	6 - 5
	A	Electrical Schematic - TML-4000 and TML-4000N (after serial number TML02-521) .....	6 - 6
	A	Electrical Schematic - Deutz Engine (before serial number TML05-213) .....	6 - 8
	B	Electrical Schematic - Lombardini and Deutz Engines (after serial number TML05-212) .....	6 - 9
	A	Electrical Schematic - Perkins Engine (before serial number TML05-362) .....	6 - 10
	A	Electrical Schematic - Perkins Engine (after serial number TML05-361) .....	6 - 11



# Parts Stocking List

## Required Parts

The following parts are required to perform maintenance procedures as outlined in the *Genie TML-4000 and TML-4000N Parts and Service Manual*.

Description	Part No.
<b>Perkins 103-10 Models</b>	
Dielectric Grease .....	66399
Oil Filter .....	85069
Air Filter .....	85081
Fuel Filter .....	(refer to Figure 9-G)
V-belt .....	85071
<b>Perkins 403C-11 Models</b>	
Dielectric Grease .....	66399
Oil Filter .....	94762
Air Filter .....	97474
Fuel Filter .....	62421
V-belt .....	85071
Valve Cover Breather .....	84860
<b>Lombardini and Deutz Models</b>	
Dielectric Grease .....	66399
Oil Filter .....	80053

## Recommended Parts

Description	Part No.
Genie Gray Paint, 12 Ounce (355 ml) Aerosol .....	1268
Genie Blue Paint, 12 Ounce (355 ml) Aerosol .....	1484
Genie Blue Paint, 1 Gallon (3.78 liters) .....	32150
Genie Gray Paint, 1 Gallon (3.78 liters) .....	32151

## Manuals

Genie Industries offers the following support documents for these models:

Title	Part No.
Genie TML-4000 and TML-4000N Operator's Manual, Second Edition (from serial number TML-01-225 to TML04-559) .....	82199
Genie TML-4000 and TML-4000N Operator's Manual, Third Edition (after serial number TML04-559) .....	97600
Manual of Responsibilities ANSI A92.3 .....	31587



This page intentionally left blank.

# How To Order Parts

Please be prepared with the following information when ordering replacement parts for your Genie product:

- Machine model number
- Machine serial number
- Genie part number
- Part description and quantity
- Purchase order number
- "Ship to" address
- Desired method of shipment
- Name and telephone number of the authorized Genie Distributor in your area

Use the Service Parts Fax Order Form on the next page and fax your order to our Parts Department.

If you don't know the name of your authorized distributor, or if your area is not currently serviced by an authorized distributor, please call Genie Industries.

## Machine Information

---

**Model**

---

**Serial Number**

---

**Date of Purchase**

---

**Authorized Genie Distributor**

---

**Phone Number**

### Genie North America

Telephone (425) 556-6551

Toll Free (877) 367-5606 in U.S.A. and Canada

Fax (425) 556-8659

### Genie UK

Parts Telephone (44) (0) 1476 584352

Parts Fax (44) (0) 1476 584340

### Genie Australia

Parts Telephone (617) 03375 1660

Parts Fax (617) 03375 1002

### Genie France

Parts Telephone (33) (0) 237 26 09 99

Parts Fax (33) (0) 237 31 50 10

### Genie Germany

Parts Telephone (49) (0) 4202 885223

Parts Fax (49) (0) 4202 885225

### Genie Scandinavia

Parts Telephone (46) (31) 3409612

Parts Fax (46) (31) 3409613

### Genie Iberica

Parts Telephone (34) (93) 5795042

### Genie Brazil

Parts Telephone (55) (114) 1665755

Parts Fax (55) (114) 1665754

### Genie Japan

Parts Telephone (81) (33) 4536082

Parts Fax (81) (33) 4536083

### Genie China

Parts Telephone (86) (215) 3852570

Parts Fax (86) (215) 3852569



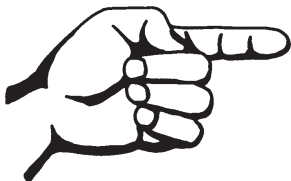

This page intentionally left blank.

# Specifications

REV A

## Machine Specifications

<b>Total lighting wattage</b>	4000 watts
<b>Fuel capacities</b>	
TML-4000	50 gallons 189 liters
TML-4000N	30 gallons 114 liters
<b>Battery - Standard</b>	
Type	12V DC
Group	70
Quantity	1
Cold cranking ampere	450
Reserve capacity @ 25A rate	105 minutes
<b>Battery - Heavy Duty</b>	
Type	12V DC
Group	31
Quantity	1
Cold cranking ampere	950
Reserve capacity @ 25A rate	190 minutes
<b>Tires and wheels</b>	
<b>Axle</b>	
Tire size	ST185/80D13
Load range	B
Lug nut torque, dry	80 ft-lbs 108 Nm
Tire pressure, maximum (cold)	50 psi 3.4 bar
<b>Airborne Noise Emissions</b>	71 dB
Maximum sound level at normal operating workstations (A-weighted)	

## Performance Specifications

<b>Tongue weight, maximum</b>	
TML-4000	145 lbs 66 kg
TML-4000N	110 lbs 50 kg
<b>Run time</b>	
TML-4000 (full load with full fuel tank)	100 hours
TML-4000N (full load with full fuel tank)	60 hours

**Continuous improvement of our products is a Genie policy. Product specifications are subject to change without notice.**

**For operational specifications, refer to the Operator's Manual.**



## SPECIFICATIONS

REV A

**Deutz F3M 1008 Engine**

<b>Displacement</b>	55.9 cu in 0.916 liters
---------------------	----------------------------

<b>Number of cylinders</b>	3
----------------------------	---

<b>Bore and stroke</b>	2.83 x 2.95 inches 72 x 75 mm
------------------------	----------------------------------

<b>Horsepower</b>	see engine rating plate
-------------------	-------------------------

<b>Firing order</b>	1 - 3 - 2
---------------------	-----------

<b>Compression ratio</b>	22.8:1
--------------------------	--------

<b>Engine speed</b>	1800 rpm
---------------------	----------

<b>Governor</b>	mechanical
-----------------	------------

**Valve clearance, cold**

Intake	0.0079 in 0.2 mm
--------	---------------------

Exhaust	0.0079 in 0.2 mm
---------	---------------------

**Lubrication system**

Oil pressure (hot @ 1800 rpm)	40 to 60 psi 2.75 to 4.1 bar
-------------------------------	---------------------------------

Oil capacity (including filter)	2.65 quarts 2.5 liters
---------------------------------	---------------------------

Oil pressure switch (engine shut-off pressure)	4.35 ±2 psi 0.3 ±0.15 bar
--	------------------------------

**Oil viscosity requirements**

Units ship with 15W-40.

Extreme operating temperatures may require the use of alternative engine oils. For oil requirements, refer to the Engine Operator Handbook on your machine.

**Engine coolant**

Capacity	5.2 quarts 4.9 liters
----------	--------------------------

Coolant temperature switch (engine shut-off temperature)	230° ±5°F 110° ±3°C
--	------------------------

**Injection system**

Injection pump make	Bosch
---------------------	-------

Injection pump pressure	6500 ±700 psi 450 ±50 bar
-------------------------	------------------------------

Injector opening pressure	1958 ±72 psi 135 ±5 bar
---------------------------	----------------------------

**Fuel requirement**

For fuel requirements, refer to the engine Operator's Manual on your machine.

**Alternator**

Output	45A, 12V DC
--------	-------------

Fan belt tension (new belt installation)	90 ± 4 ft-lbs 400 ±20 N
--	----------------------------

Fan belt tension (retension)(after 15 min of use)	56 ± 4 ft-lbs 250 ±20 N
---	----------------------------

**Temperature sensor**

Engine block temperature, maximum	302°F 150°C
-----------------------------------	----------------



REV A

SPECIFICATIONS

## Lombardini LDW-1003/L /Deutz F3M 1008F Engine

<b>Displacement</b>	62.85 cu in 1.03 liters
<b>Number of cylinders</b>	3
<b>Bore and stroke</b>	2.95 x 3.06 inches 75 x 77.6 mm
<b>Horsepower</b>	see engine rating plate
<b>Firing order</b>	1 - 3 - 2
<b>Compression ratio</b>	22.8:1
<b>Engine speed</b>	1800 rpm
<b>Governor</b>	mechanical
<b>Valve clearance, cold</b>	
Intake	0.0079 in 0.2 mm
Exhaust	0.0079 in 0.2 mm
<b>Lubrication system</b>	
Oil pressure (hot @ 1800 rpm)	40 to 60 psi 2.75 to 4.1 bar
Oil capacity (including filter)	2.65 quarts 2.5 liters
Oil pressure switch (engine shut-off pressure)	4.35 ±2 psi 0.3 ±0.15 bar

### Oil viscosity requirements

Units ship with 15W-40.

Extreme operating temperatures may require the use of alternative engine oils. For oil requirements, refer to the Engine Operator Handbook on your machine.

### Engine coolant

Capacity	5.2 quarts 4.9 liters
Coolant temperature switch (engine shut-off temperature)	230° ±5°F 110° ±3°C

### Injection system

Injection pump make	Bosch
Injection pump pressure	6500 ±700 psi 450 ±50 bar
Injector opening pressure	1958 ±72 psi 135 ±5 bar

### Fuel requirement

For fuel requirements, refer to the engine Operator's Manual on your machine.

### Alternator

Output	45A, 12V DC
Fan belt tension (new belt installation)	90 ± 4 ft-lbs 400 ±20 N
Fan belt tension (retension)(after 15 min of use)	56 ± 4 ft-lbs 250 ±20 N

### Temperature sensor

Engine block temperature, maximum	302°F 150°C
-----------------------------------	----------------

## SPECIFICATIONS

REV A

**Perkins 103-10 Engine**

<b>Displacement</b>	58.21 cu in 0.954 liters
---------------------	-----------------------------

<b>Number of cylinders</b>	3
----------------------------	---

<b>Bore and stroke</b>	3.3 x 3.15 inches 84 x 80 mm
------------------------	---------------------------------

<b>Horsepower</b>	see engine rating plate
-------------------	-------------------------

<b>Firing order</b>	1 - 2 - 3
---------------------	-----------

<b>Compression ratio</b>	23:1
--------------------------	------

<b>Compression pressure</b>	425 psi 29.3 bar
-----------------------------	---------------------

Pressure of the lowest cylinder must be within 50 psi / 3.45 bar of the highest cylinder, though at no time less than 360 psi / 24.8 bar

<b>Engine speed</b>	
models with 50 Hz generator	1500 rpm
models with 60 Hz generator	1800 rpm

<b>Governor</b>	all-speed mechanical
-----------------	----------------------

**Valve clearance, cold**

Intake	0.0078 in 0.2 mm
--------	---------------------

Exhaust	0.0078 in 0.2 mm
---------	---------------------

**Lubrication system**

Oil pressure (hot @ 1800 rpm)	40 to 60 psi 2.75 to 4.1 bar
-------------------------------	---------------------------------

Oil capacity (including filter)	3.7 quarts 3.5 liters
---------------------------------	--------------------------

Oil pressure switch (engine shut-off pressure)	5 psi 0.34 bar
--	-------------------

**Oil viscosity requirements**

Units ship with 15W-40.  
Extreme operating temperatures may require the use of alternative engine oils. For oil requirements, refer to the Engine Operating Instructions on your machine.

**Engine coolant**

Capacity	5.5 quarts 5.21 liters
----------	---------------------------

Coolant temperature switch (engine shut-off temperature)	221° ±7°F 105° ±4°C
--	------------------------

**Injection system**

Injection pump make	Kikicexel
---------------------	-----------

Injection pump pressure	1764 psi 121 bar
-------------------------	---------------------

**Fuel requirement**

For fuel requirements, refer to the engine Operator's Manual on your machine.

**Alternator**

Output	15A, 12V DC
--------	-------------

Fan belt deflection (between crankshaft pulley and alternator with finger force of approximately 11 ft-lbs / 49 N)	0.19 in 5 mm
--	-----------------

REV A

SPECIFICATIONS

## Perkins 403C-11 Engine

<b>Displacement</b>	69 cu in 1.131 liters
---------------------	--------------------------

<b>Number of cylinders</b>	3
----------------------------	---

<b>Bore and stroke</b>	3.03 x 3.19 inches 77 x 81 mm
------------------------	----------------------------------

<b>Horsepower</b>	see engine rating plate
-------------------	-------------------------

<b>Firing order</b>	1 - 2 - 3
---------------------	-----------

<b>Compression ratio</b>	23:1
--------------------------	------

<b>Compression pressure</b>	425 psi 29.3 bar
-----------------------------	---------------------

Pressure of the lowest cylinder must be within 50 psi / 3.45 bar of the highest cylinder, though at no time less than 360 psi / 24.8 bar

<b>Engine speed</b>	
models with 50 Hz generator	1500 rpm
models with 60 Hz generator	1800 rpm

<b>Governor</b>	mechanical
-----------------	------------

### Valve clearance, cold

Intake	0.0078 in 0.2 mm
--------	---------------------

Exhaust	0.0078 in 0.2 mm
---------	---------------------

### Lubrication system

Oil pressure (hot @ 1800 rpm)	40 to 60 psi 2.75 to 4.1 bar
-------------------------------	---------------------------------

Oil capacity (including filter)	5.18 quarts 4.9 liters
---------------------------------	---------------------------

Oil pressure switch (engine shut-off pressure)	7 psi 0.48 bar
--	-------------------

### Oil viscosity requirements

Units ship with 15W-40.

Extreme operating temperatures may require the use of alternative engine oils. For oil requirements, refer to the Engine User's Handbook on your machine.

### Engine coolant

Capacity	5.5 quarts 5.21 liters
----------	---------------------------

Coolant temperature switch (engine shut-off temperature)	221° ±7°F 105° ±4°C
--	------------------------

### Injection system

Injection pump make	Kikicexel
---------------------	-----------

Injection pump pressure	1764 psi 121 bar
-------------------------	---------------------

### Fuel requirement

For fuel requirements, refer to the engine Operator's Manual on your machine.

### Alternator

Output	15A, 12V DC
--------	-------------

Fan belt deflection (along longest free length with finger force of approximately 11 ft-lbs / 49 N)	0.19 in 5 mm
---	-----------------

## SPECIFICATIONS

REV A

**Leroy Somer Generator**

<b>Generator speed @ full load</b>	60 Hz 1800 rpm
<b>Temperature, ambient maximum</b>	104°F 40°C
<b>Power</b>	6 kw
<b>Capacitor (disconnected)</b>	70 µF @ ±10%
<b>Capacitor (disconnected)</b>	22.5 µF @ ± 5%

**Mecc Alte Generator**



<b>Generator rpm @ full load</b>	50 Hz 1500 rpm 60 Hz 1800 rpm
<b>Temperature, ambient maximum</b>	104°F 40°C
<b>Power</b>	6 kw
<b>Capacitor (disconnected)</b>	
220V / 50Hz	50 µF @ 3.4V ±10%
240V / 60Hz	70 µF @ 6.3V ±10%





**Marathon Generator**

<b>Generator speed @ full load</b>	60 Hz 1800 rpm
<b>Temperature, ambient maximum</b>	104°F 40°C
<b>Power</b>	6 kw
<b>Capacitor (disconnected)</b>	45 µF

REV A

SPECIFICATIONS

<b>SAE FASTENER TORQUE CHART</b>											
• This chart is to be used as a guide only unless noted elsewhere in this manual •											
SIZE	THREAD	Grade 5 				Grade 8 				A574 High Strength Black Oxide Bolts	
		LUBED		DRY		LUBED		DRY		LUBED	
		in-lbs	Nm	in-lbs	Nm	in-lbs	Nm	in-lbs	Nm	in-lbs	Nm
1/4	20	100	11.3	80	9	140	15.8	110	12.4	130	14.7
	28	90	10.1	120	13.5	120	13.5	160	18	140	15.8
		LUBED		DRY		LUBED		DRY		LUBED	
		ft-lbs	Nm	ft-lbs	Nm	ft-lbs	Nm	ft-lbs	Nm	ft-lbs	Nm
5/16	18	13	17.6	17	23	18	24	25	33.9	21	28.4
	24	14	19	19	25.7	20	27.1	27	36.6	24	32.5
3/8	16	23	31.2	31	42	33	44.7	44	59.6	38	51.5
	24	26	35.2	35	47.4	37	50.1	49	66.4	43	58.3
7/16	14	37	50.1	49	66.4	50	67.8	70	94.7	61	82.7
	20	41	55.5	55	74.5	60	81.3	80	108.4	68	92.1
1/2	13	57	77.3	75	101.6	80	108.4	110	149	93	126
	20	64	86.7	85	115	90	122	120	162	105	142
9/16	12	80	108.4	110	149	120	162	150	203	130	176
	18	90	122	120	162	130	176	170	230	140	189
5/8	11	110	149	150	203	160	217	210	284	180	244
	18	130	176	170	230	180	244	240	325	200	271
3/4	10	200	271	270	366	280	379	380	515	320	433
	16	220	298	300	406	310	420	420	569	350	474
7/8	9	320	433	430	583	450	610	610	827	510	691
	14	350	474	470	637	500	678	670	908	560	759
1	8	480	650	640	867	680	922	910	1233	770	1044
	12	530	718	710	962	750	1016	990	1342	840	1139
1.125	7	590	800	790	1071	970	1315	1290	1749	1090	1477
	12	670	908	890	1206	1080	1464	1440	1952	1220	1654
1.25	7	840	1138	1120	1518	1360	1844	1820	2467	1530	2074
	12	930	1260	1240	1681	1510	2047	2010	2725	1700	2304
1.5	6	1460	1979	1950	2643	2370	3213	3160	4284	2670	3620
	12	1640	2223	2190	2969	2670	3620	3560	4826	3000	4067

<b>METRIC FASTENER TORQUE CHART</b>																
• This chart is to be used as a guide only unless noted elsewhere in this manual •																
Size (mm)	Class 4.6 				Class 8.8 				Class 10.9 				Class 12.9 			
	LUBED		DRY		LUBED		DRY		LUBED		DRY		LUBED		DRY	
	in-lbs	Nm	in-lbs	Nm	in-lbs	Nm	in-lbs	Nm	in-lbs	Nm	in-lbs	Nm	in-lbs	Nm	in-lbs	Nm
5	16	1.8	21	2.4	41	4.63	54	6.18	58	6.63	78	8.84	68	7.75	91	10.3
6	19	3.05	36	4.07	69	7.87	93	10.5	100	11.3	132	15	116	13.2	155	17.6
7	45	5.12	60	6.83	116	13.2	155	17.6	167	18.9	223	25.2	1.95	22.1	260	29.4
	LUBED		DRY		LUBED		DRY		LUBED		DRY		LUBED		DRY	
	ft-lbs	Nm	ft-lbs	Nm	ft-lbs	Nm	ft-lbs	Nm	ft-lbs	Nm	ft-lbs	Nm	ft-lbs	Nm	ft-lbs	Nm
8	5.4	7.41	7.2	9.88	14	19.1	18.8	25.5	20.1	27.3	26.9	36.5	23.6	32	31.4	42.6
10	10.8	14.7	14.4	19.6	27.9	37.8	37.2	50.5	39.9	54.1	53.2	72.2	46.7	63.3	62.3	84.4
12	18.9	25.6	25.1	34.1	48.6	66	64.9	88	69.7	94.5	92.2	125	81	110	108	147
14	30.1	40.8	40	54.3	77.4	105	103	140	110	150	147	200	129	175	172	234
16	46.9	63.6	62.5	84.8	125	170	166	226	173	235	230	313	202	274	269	365
18	64.5	87.5	86.2	117	171	233	229	311	238	323	317	430	278	377	371	503
20	91	124	121	165	243	330	325	441	337	458	450	610	394	535	525	713
22	124	169	166	225	331	450	442	600	458	622	612	830	536	727	715	970
24	157	214	210	285	420	570	562	762	583	791	778	1055	682	925	909	1233



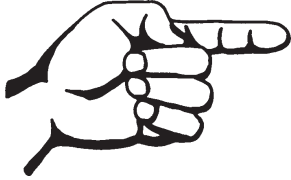

This page intentionally left blank.

# Scheduled Maintenance Procedures



## Observe and Obey:

- ☑ Maintenance inspections shall be completed by a person trained and qualified on the maintenance of this machine.
- ☑ Scheduled maintenance inspections shall be completed daily, quarterly, semi-annually, annually and every 2 years as specified on the *Maintenance Inspection Report*.

**⚠ WARNING** Failure to perform each procedure as presented and scheduled could result in death, serious injury or substantial damage.

- ☑ Immediately tag and remove from service a damaged or malfunctioning machine.
- ☑ Repair any machine damage or malfunction before operating the machine.
- ☑ Use only Genie approved replacement parts.
- ☑ Machines that have been out of service for a period longer than 3 months must complete the quarterly inspection.
- ☑ Unless otherwise specified, perform each maintenance procedure with the machine in the following configuration:
  - Machine parked on a firm, level surface
  - Mast in the stowed position
  - Light switches in the off position
  - Key switch in the off position
  - Wheels chocked

## About This Section

This section contains detailed procedures for each scheduled maintenance inspection.

Each procedure includes a description, safety warnings and step-by-step instructions.

### Symbols Legend



Safety alert symbol—used to alert personnel to potential personal injury hazards. Obey all safety messages that follow this symbol to avoid possible injury or death.

#### ⚠ DANGER

Indicates an imminently hazardous situation which, if not avoided, will result in death or serious injury.

#### ⚠ WARNING

Indicates a potentially hazardous situation which, if not avoided, could result in death or serious injury.

#### ⚠ CAUTION

Indicates a potentially hazardous situation which, if not avoided, may cause minor or moderate injury.

#### NOTICE

Indicates a potentially hazardous situation which, if not avoided, may result in property damage.

- ⦿ Indicates that a specific result is expected after performing a series of steps.
- ⊗ Indicates that an incorrect result has occurred after performing a series of steps.

## SCHEDULED MAINTENANCE PROCEDURES

**Maintenance Symbols Legend**

Note: The following symbols have been used in this manual to help communicate the intent of the instructions. When one or more of the symbols appears at the beginning of a maintenance procedure, it conveys the meaning below.



Indicates that tools will be required to perform this procedure.



Indicates that new parts will be required to perform this procedure.



Indicates that a cold motor or pump will be required to perform this procedure.



Indicates that dealer service will be required to perform this procedure.

**Pre-delivery Preparation Report**

The pre-delivery preparation report contains checklists for each type of scheduled inspection.

Make copies of the *Pre-delivery Preparation* report to use for each inspection. Store completed forms as required.

**Maintenance Schedule**

There are five types of maintenance inspections that must be performed according to a schedule—daily, quarterly, semi-annually, annually, and two year. The *Scheduled Maintenance Procedures Section and the Maintenance Inspection Report* have been divided into five subsections—A, B, C, D, and E. Use the following chart to determine which group(s) of procedures are required to perform a scheduled inspection.

Inspection	Checklist
Daily or every 8 hours	A
Quarterly or every 250 hours	A + B
Semi-annually or every 500 hours	A + B + C
Annually or every 1000 hours	A + B + C + D
Two year or every 2000 hours	A + B + C + D + E

**Maintenance Inspection Report**

The maintenance inspection report contains checklists for each type of scheduled inspection.

Make copies of the *Maintenance Inspection Report* to use for each inspection. Store completed forms for three years.



# Pre-Delivery Preparation

## Fundamentals

It is the responsibility of the dealer to perform the Pre-delivery Preparation.

The Pre-delivery Preparation is performed prior to each delivery. The inspection is designed to discover if anything is apparently wrong with a machine before it is put into service.

A damaged or modified machine must never be used. If damage or any variation from factory delivered condition is discovered, the machine must be tagged and removed from service.

Repairs to the machine may only be made by a qualified service technician, according to the manufacturer's specifications.

Scheduled maintenance inspections shall be performed by qualified service technicians, according to the manufacturer's specifications and the requirements listed in the responsibilities manual.

## Instructions

Use the operator's manual on your machine.

The Pre-delivery Preparation consists of completing the Pre-operation Inspection, the Maintenance items and the Function Tests.

Use this form to record the results. Place a check in the appropriate box after each part is completed. Follow the instructions in the operator's manual.

If any inspection receives an N, remove the machine from service, repair and re-inspect it. After repair, place a check in the R box.

### Legend

Y = yes, completed

N = no, unable to complete

R = repaired

### Comments

Pre-Delivery Preparation	Y	N	R
Pre-operation inspection completed			
Maintenance items completed			
Function tests completed			

Model

Serial number

Date

Machine owner

Inspected by (print)

Inspector signature

Inspector title

Inspector company



**Genie Industries USA**  
18340 NE 76th Street  
PO Box 97030  
Redmond, WA 98073-9730  
(425) 881-1800

**Genie UK**  
The Maltings, Wharf Road  
Grantham, Lincolnshire  
NG31-6BH England  
(44) 1476-584333

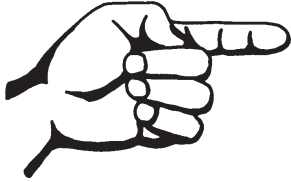

This page intentionally left blank.

# Maintenance Inspection Report

<b>Model</b>
<b>Serial number</b>
<b>Date</b>
<b>Hour meter</b>
<b>Machine owner</b>
<b>Inspected by (print)</b>
<b>Inspector signature</b>
<b>Inspector title</b>
<b>Inspector company</b>

**Instructions**

- Make copies of this report to use for each inspection.
- Select the appropriate checklist(s) for the type of inspection to be performed.

<input type="checkbox"/>	<b>Daily or 8 hours Inspection:</b>	<b>A</b>
<input type="checkbox"/>	<b>Quarterly or 250 hours Inspection:</b>	<b>A+B</b>
<input type="checkbox"/>	<b>Semi-annually or 500 hours Inspection:</b>	<b>A+B+C</b>
<input type="checkbox"/>	<b>Annually or 1000 hours Inspection:</b>	<b>A+B+C+D</b>
<input type="checkbox"/>	<b>Two year or 2000 hours Inspection:</b>	<b>A+B+C+D+E</b>

- Place a check in the appropriate box after each inspection procedure is completed.
- Use the step-by-step procedures in this section to learn how to perform these inspections.
- If any inspection receives an "N", tag and remove the machine from service, repair and re-inspect it. After repair, place a check in the "R" box.

**Legend**

Y = yes, acceptable  
 N = no, remove from service  
 R = repaired

<b>Checklist A - Rev C</b>		<b>Y</b>	<b>N</b>	<b>R</b>
A-1	Manuals and decals			
A-2	Pre-operation inspect			
A-3	Function tests			
<b>Perform every 8 hours:</b>				
A-4	Engine maintenance - Perkins models			
A-5	Winch maintenance			
<b>Perform every 10 hours:</b>				
A-6	Engine maintenance - Deutz models			
<b>Perform every 50 miles:</b>				
A-7	Hitch maintenance			
<b>Perform after 40 hours:</b>				
A-8	30 day service			
<b>Perform every 100 hours:</b>				
A-9	Engine maintenance - Perkins 103-10 models			
<b>Perform every 125 hours:</b>				
A-10	Engine maintenance - Deutz models			
<b>Perform every 200 hours:</b>				
A-11	Engine maintenance - Perkins 103-10 models			
A-12	Generator maintenance - Marathon models			

<b>Checklist B - Rev C</b>		<b>Y</b>	<b>N</b>	<b>R</b>
B-1	Battery			
B-2	Electrical wiring			
B-3	Tires and wheels			
B-4	Engine maintenance - Deutz models			
B-5	Engine maintenance - Perkins 403C11 models			
B-6	Hitch maintenance			
<b>Perform every 400 hours:</b>				
B-7	Engine maintenance - Perkins 103-10 models			
<b>Perform every 3000 miles:</b>				
B-8	Axle maintenance			

<b>Checklist C - Rev B</b>		<b>Y</b>	<b>N</b>	<b>R</b>
C-1	Cable and pulleys			
C-2	Engine maintenance - Perkins 403C11 models			
C-3	Engine maintenance - Deutz models			
<b>Perform every 600 hours:</b>				
C-4	Engine maintenance - Perkins 103-10 models			
<b>Perform every 6000 miles:</b>				
C-5	Axle maintenance			

<b>Checklist D - Rev B</b>		<b>Y</b>	<b>N</b>	<b>R</b>
D-1	Engine maintenance - Deutz models			
D-2	Engine maintenance - Perkins 403C11 models			
D-3	Generator maintenance - Leroy Somer models			
D-4	Jack maintenance			
D-5	Axle maintenance			

<b>Checklist E - Rev B</b>		<b>Y</b>	<b>N</b>	<b>R</b>
E-1	Engine maintenance - Deutz models			
E-2	Engine maintenance - Perkins 403C11 models			
E-3	Engine maintenance - Perkins 403C11 models			
E-4	Generator maintenance - Marathon models			
E-5	Generator maintenance - Leroy Somer models			

**Comments**



# Checklist A Procedures

REV A

## A-1 Inspect the Manuals and Decals

Genie specifications require that this procedure be performed every 8 hours or daily, whichever comes first.

Maintaining the operator's and safety manuals in good condition is essential to safe machine operation. Manuals are included with each machine and should be stored in the container provided in the platform. An illegible or missing manual will not provide safety and operational information necessary for a safe operating condition.

In addition, maintaining all of the safety and instructional decals in good condition is mandatory for safe machine operation. Decals alert operators and personnel to the many possible hazards associated with using this machine. They also provide users with operation and maintenance information. An illegible decal will fail to alert personnel of a procedure or hazard and could result in unsafe operating conditions.

- 1 Check to make sure that the operator's and safety manuals are present and complete in the storage container on the platform.
  - 2 Examine the pages of each manual to be sure that they are legible and in good condition.
- ⦿ Result: The operator's manual is appropriate for the machine and all manuals are legible and in good condition.
  - ✗ Result: The operator's manual is not appropriate for the machine or all manuals are not in good condition or is illegible. Remove the machine from service until the manual is replaced.

- 3 Open the operator's manual to the decals inspection section. Carefully and thoroughly inspect all decals on the machine for legibility and damage.
- ⦿ Result: The machine is equipped with all required decals, and all decals are legible and in good condition.
  - ✗ Result: The machine is not equipped with all required decals, or one or more decals are illegible or in poor condition. Remove the machine from service until the decals are replaced.
- 4 Always return the manuals to the storage container after use.

Note: Contact your authorized Genie distributor or Genie Industries if replacement manuals or decals are needed.

REV A

CHECKLIST A PROCEDURES

## A-2 Perform Pre-operation Inspection

Genie specifications require that this procedure be performed every 8 hours or daily, whichever comes first.

Completing a Pre-operation Inspection is essential to safe machine operation. The Pre-operation Inspection is a visual inspection performed by the operator prior to each work shift. The inspection is designed to discover if anything is apparently wrong with a machine before the operator performs the function tests. The Pre-operation Inspection also serves to determine if routine maintenance procedures are required.

Complete information to perform this procedure is available in the appropriate operator's manual. Refer to the Operator's Manual on your machine.

## A-3 Perform Function Tests

Genie specifications require that this procedure be performed every 8 hours or daily, whichever comes first.

Completing the function tests is essential to safe machine operation. Function tests are designed to discover any malfunctions before the machine is put into service. A malfunctioning machine must never be used. If malfunctions are discovered, the machine must be tagged and removed from service.

Complete information to perform this procedure is available in the appropriate operator's manual. Refer to the Operator's Manual on your machine.

## A-4 Perform Engine Maintenance - Perkins Models



Engine specifications require that this procedure be performed every 8 hours or daily, whichever comes first.

Required maintenance procedures and additional engine information is available in the *Perkins 100 Series Operating Instructions* (Perkins part number 100816243-0695) OR the *Perkins 400 Series User's Handbook* (Perkins part number 100816460).

---

<b>Perkins 100 Series Operating Instructions</b>	
Genie part number	150137

---

<b>Perkins 400 Series User's Handbook</b>	
Genie part number	97360

---

## A-5 Perform Winch Maintenance



Winch specifications require that this procedure be performed every 8 hours or daily, whichever comes first.

Required maintenance procedures and additional winch information is available in the *Fulton Winch Operator's Manual* (Fulton part number F1928).

---

<b>Fulton Winch Operator's Manual</b>	
Genie part number	150143

---

## CHECKLIST A PROCEDURES

REV A

## A-6 Perform Engine Maintenance - Lombardini and Deutz Models



Engine specifications require that this procedure be performed every 10 hours or daily, whichever comes first.

Required maintenance procedures and additional engine information is available in the *Lombardini LDW 1003/L or Deutz 1008 Operation Manual* (Deutz part number 0297 9689).

---

<b>Deutz 1008 Operation Manual</b>	
Genie part number	150108

---

<b>Lombardini LDW 1003/L Operation Manual</b>	
Genie part number	116031

---

## A-7 Perform Hitch Maintenance



Hitch specifications require that this procedure be performed every 50 miles.

Required maintenance procedures and additional hitch information is available in the *Fulton Coupler Use Manual* (Fulton part number F1937).

---

<b>Fulton Coupler Use Manual</b>	
Genie part number	150139

---

REV A

CHECKLIST A PROCEDURES

## A-8 Perform 30 Day Service



The 30 day maintenance procedure is a one time procedure to be performed after the first 30 days or 40 hours of usage. After this interval, refer to the maintenance tables for continued scheduled maintenance.

1 Perform the following maintenance procedures:

- B-3      Inspect the Tires and Wheels  
(including castle nut torque)

## A-9 Perform Engine Maintenance - Perkins 103-10 Models



Engine specifications require that this procedure be performed every 100 hours or quarterly, whichever comes first.

Required maintenance procedures and additional engine information is available in the *Perkins 100 Series Operating Instructions* (Perkins part number 100816243-0695).

---

**Perkins 100 Series Operating Instructions**

Genie part number

150137

---

## A-10 Perform Engine Maintenance - Lombardini and Deutz Models



Engine specifications require that this procedure be performed every 125 hours or quarterly, whichever comes first.

Required maintenance procedures and additional engine information is available in the *Lombardini LDW 1003/L or Deutz 1008 Operation Manual* (Deutz part number 0297 9689).

---

<b>Deutz 1008 Operation Manual</b>	
Genie part number	150108

---

<b>Lombardini LDW 1003/L Operation Manual</b>	
Genie part number	116031

---

## A-11 Perform Engine Maintenance - Perkins 103-10 Models



Engine specifications require that this procedure be performed every 200 hours or quarterly, whichever comes first.

Required maintenance procedures and additional engine information is available in the *Perkins 100 Series Operating Instructions* (Perkins part number 100816243-0695).

---

<b>Perkins 100 Series Operating Instructions</b>	
Genie part number	150137

---

## A-12 Perform Generator Maintenance - Marathon Models



Generator specifications require that this procedure be performed every 200 hours or quarterly, whichever comes first.

Required maintenance procedures and additional generator information is available in the *Marathon Generator Service Manual* (Marathon part number SM301).

---

<b>Marathon Generator Service Manual</b>	
Genie part number	150109

---



# Checklist B Procedures

REV A

## B-1 Inspect the Battery



Genie requires that this procedure be performed every 250 hours or quarterly, whichever comes first.

Proper battery condition is essential to good machine performance and operational safety. Improper fluid levels or damaged cables and connections can result in component damage and hazardous conditions.

**⚠ WARNING** Electrocutation hazard. Contact with electrically charged circuits could result in death or serious injury. Remove all rings, watches and other jewelry.

**⚠ WARNING** Bodily injury hazard. Batteries contain acid. Avoid spilling or contacting battery acid. Neutralize battery acid spills with baking soda and water.

- 1 Put on protective clothing and eye wear.
- 2 Be sure that the battery cable connections are free of corrosion.

Note: Adding terminal protectors and a corrosion preventative sealant will help eliminate corrosion on the battery terminals and cables.

- 3 Be sure that the battery retainers and cable connections are tight.
- 4 Fully charge the battery. Allow the battery to rest 24 hours before performing this procedure to allow the battery cells to equalize.
- 5 Remove the battery vent caps and check the specific gravity of each battery cell with a hydrometer. Note the results.

- 6 Check the ambient air temperature and adjust the specific gravity reading for each cell as follows:
  - Add 0.004 to the reading of each cell for every 10° / 5.5° C above 80° F / 26.7° C.
  - Subtract 0.004 from the reading of each cell for every 10° / 5.5° C below 80° F / 26.7° C.
- ⊙ Result: All battery cells display an adjusted specific gravity of 1.277 or higher. The battery is fully charged. Proceed to step 10.
- ✗ Result: One or more battery cells display a specific gravity of 1.217 or below. Proceed to step 7.
- 7 Perform an equalizing charge OR fully charge the batteries and allow the battery to rest at least 6 hours.
- 8 Remove the battery vent caps and check the specific gravity of each battery cell with a hydrometer. Note the results.
- 9 Check the ambient air temperature and adjust the specific gravity reading for each cell as follows:
  - Add 0.004 to the reading of each cell for every 10° / 5.5° C above 80° F / 26.7° C.
  - Subtract 0.004 from the reading of each cell for every 10° / 5.5° C below 80° F / 26.7° C.
- ⊙ Result: All battery cells display a specific gravity of 1.277 or greater. The battery is fully charged. Proceed to step 10.
- ✗ Result: The difference in specific gravity readings between cells is greater than 0.1 OR the specific gravity of one or more cells is less than 1.217. Replace the battery.
- 10 Check the battery acid level. If needed, replenish with distilled water to 1/8 inch / 3 mm below the bottom of the battery fill tube. Do not overfill.
- 11 Install the vent caps and neutralize any electrolyte that may have spilled.

## CHECKLIST B PROCEDURES

REV A

## B-2 Inspect the Electrical Wiring



Genie requires that this procedure be performed every 250 hours or quarterly, whichever comes first.

Maintaining electrical wiring in good condition is essential to safe operation and good machine performance. Failure to find and replace burnt, chafed, corroded or pinched wires could result in unsafe operating conditions and may cause component damage.

**⚠ WARNING** Electrocutation hazard. Contact with hot or live circuits could result in death or serious injury. Remove all rings, watches and other jewelry.

- 1 Inspect the following areas for burnt, chafed, corroded and loose wires, and for a liberal coating of dielectric grease in the harness connections:
  - Mast
  - Chassis
  - Trailer lighting
- 2 Open the chassis side covers and inspect for a liberal coating of dielectric grease in the harness connections between the generator and the mast light assemblies.
- 3 Inspect the engine and generator area for burnt, chafed, corroded, pinched and loose wires, and and for a liberal coating of dielectric grease in the harness connections.

## B-3 Inspect the Tires and Wheels (including lug nut torque)



Genie requires that this procedure be performed every 250 hours or quarterly, whichever comes first.

Maintaining the tires and wheels in good condition is essential to safe operation and good performance. Tire and/or wheel failure could result in a machine tip-over. Component damage may also result if problems are not discovered and repaired in a timely fashion.

- 1 Check the tire tread and sidewalls for cuts, cracks, punctures and unusual wear.
- 2 Check each wheel for damage, bends and cracked welds.
- 3 Check each lug nut or lug bolt for proper torque. Refer to Section 2, *Specifications*.
- 4 Check the air pressure of each tire. Refer to Section 2, *Specifications*.

REV A

CHECKLIST B PROCEDURES

**B-4  
Perform Engine Maintenance -  
Lombardini and Deutz Models**



Engine specifications require that this procedure be performed every 250 hours or quarterly, whichever comes first.

Required maintenance procedures and additional engine information is available in the *Lombardini LDW 1003/L or Deutz 1008 Operation Manual* (Deutz part number 0297 9689).

---

<b>Deutz 1008 Operation Manual</b>	
Genie part number	150108

---

<b>Lombardini LDW 1003/L Operation Manual</b>	
Genie part number	116031

---

**B-5  
Perform Engine Maintenance -  
Perkins 403C-11 Models**



Engine specifications require that this procedure be performed every 250 hours or quarterly, whichever comes first.

Required maintenance procedures and additional engine information is available in the *Perkins 400 Series User's Handbook* (Perkins part number 100816460).

---

<b>Perkins 400 Series User's Handbook</b>	
Genie part number	97360

---

## CHECKLIST B PROCEDURES

REV A

## B-6 Perform Hitch Maintenance



Hitch specifications require that this procedure be performed quarterly.

Required maintenance procedures and additional hitch information is available in the *Fulton Coupler Use Manual* (Fulton part number F1937).

---

### Fulton Coupler Use Manual

Genie part number 150139

---

## B-7 Perform Engine Maintenance - Perkins 103-10 Models



Engine specifications require that this procedure be performed every 400 hours or semi-annually, whichever comes first.

Required maintenance procedures and additional engine information is available in the *Perkins 100 Series Operating Instructions* (Perkins part number 100816243-0695).

---

### Perkins 100 Series Operating Instructions

Genie part number 150137

---

## B-8 Perform Axle Maintenance



Axle specifications require that this procedure be performed quarterly or every 3000 miles, whichever comes first.

Proper axle maintenance, following the axle manufacturer's maintenance schedule, is essential to good axle performance and service life. Failure to perform the maintenance procedures can lead to poor axle performance and component damage.

Required maintenance procedures and additional axle information is available in the *Dexter Axle Operation Maintenance Service Manual* (Dexter part number LIT-001-00).

---

### Dexter Axle Operation Maintenance Service Manual

Genie part number 84376

---

# Checklist C Procedures

REV A

## C-1 Inspect the Cable and Cable Pulleys

Genie specifications require that this procedure be performed every 500 hours or semi-annually, whichever comes first.

Detection of damage to the cable or pulleys is essential for safe machine operation. An unsafe working condition exists if these components are damaged and do not operate smoothly. Regular inspection of this system allows the inspector to identify changes in the operating condition that may indicate damage.

- 1 Visually inspect the cable and components for the following:
  - frayed or broken wire strands
  - kinks in the cable
  - corrosion
  - paint or foreign materials
  - cable is properly secured to the winch
  - cable is on the pulleys
  - broken or damaged pulleys
  - unusual or excessive pulley wear

## C-2 Perform Engine Maintenance - Perkins 403C-11 Models



Engine specifications require that this procedure be performed every 500 hours or semi-annually, whichever comes first.

Required maintenance procedures and additional engine information is available in the *Perkins 400 Series User's Handbook* (Perkins part number 100816460).

---

### **Perkins 400 Series User's Handbook**

Genie part number

97360

## CHECKLIST C PROCEDURES

REV A

### C-3 Perform Engine Maintenance - Lombardini and Deutz Models



Engine specifications require that this procedure be performed every 500 hours or semi-annually, whichever comes first.

Required maintenance procedures and additional engine information is available in the *Lombardini LDW 1003/L or Deutz 1008 Operation Manual* (Deutz part number 0297 9689).

---

<b>Deutz 1008 Operation Manual</b>	
Genie part number	150108

---

<b>Lombardini LDW 1003/L Operation Manual</b>	
Genie part number	116031

---

### C-4 Perform Engine Maintenance - Perkins 103-10 Models



Engine specifications require that this procedure be performed every 600 hours or annually, whichever comes first.

Required maintenance procedures and additional engine information is available in the *Perkins 100 Series Operating Instructions* (Perkins part number 100816243-0695).

---

<b>Perkins 100 Series Operating Instructions</b>	
Genie part number	150137

---

### C-5 Perform Axle Maintenance



Axle specifications require that this procedure be performed every 6 months or 6000 miles, whichever comes first.

Required maintenance procedures and additional axle information is available in the *Dexter Axle Operation Maintenance Service Manual* (Dexter part number LIT-001-00).

---

<b>Dexter Axle Operation Maintenance Service Manual</b>	
Genie part number	84376

---

# Checklist D Procedures

REV A

## D-1 Perform Engine Maintenance - Lombardini and Deutz Models



Engine specifications require that this procedure be performed every 1000 hours or annually, whichever comes first.

Required maintenance procedures and additional engine information is available in the *Lombardini LDW 1003/L or Deutz 1008 Operation Manual* (Deutz part number 0297 9689).

---

<b>Deutz 1008 Operation Manual</b>	
Genie part number	150108

---

<b>Lombardini LDW 1003/L Operation Manual</b>	
Genie part number	116031

---

## D-2 Perform Engine Maintenance - Perkins 403C-11 Models



Engine specifications require that this procedure be performed every 1000 hours.

Required maintenance procedures and additional engine information is available in the *Perkins 400 Series User's Handbook* (Perkins part number 100816460).

---

<b>Perkins 400 Series User's Handbook</b>	
Genie part number	97360

---

## CHECKLIST D PROCEDURES

REV A

### D-3 Perform Generator Maintenance - Leroy Somer Models



Generator specifications require that this procedure be performed annually.

Required maintenance procedures and additional generator information is available in the *Leroy Somer Installation and Maintenance Manual* (Leroy Somer part number 1903-4.33).

---

**Leroy Somer Installation and Maintenance Manual**  
Genie part number 150138

---

### D-4 Perform Tongue Jack and Outrigger Jack Maintenance



Tongue jack specifications require that this procedure be performed annually.

Required maintenance procedures and additional hitch information is available in the *Cequent Tongue Jack Use Manual* (Cequent part number F3282ML).

---

**Cequent Tongue Jack Use Manual**  
Genie part number 150140

---

### D-5 Perform Axle Maintenance



Axle specifications require that this procedure be performed annually or every 12,000 miles, whichever comes first.

Required maintenance procedures and additional axle information is available in the *Dexter Axle Operation Maintenance Service Manual* (Dexter part number LIT-001-00).

---

**Dexter Axle Operation Maintenance Service Manual**  
Genie part number 84376

---



# Checklist E Procedures

REV A

## E-1

### Perform Engine Maintenance - Lombardini and Deutz Models



Engine specifications require that this procedure be performed every 2000 hours or two years, whichever comes first.

Required maintenance procedures and additional engine information is available in the *Lombardini LDW 1003/L or Deutz 1008 Operation Manual* (Deutz part number 0297 9689).

---

<b>Deutz 1008 Operation Manual</b>	
Genie part number	150108

---

<b>Lombardini LDW 1003/L Operation Manual</b>	
Genie part number	116031

---

## E-2

### Perform Engine Maintenance - Perkins 403C-11 Models



Engine specifications require that this procedure be performed every 2000 hours.

Required maintenance procedures and additional engine information is available in the *Perkins 400 Series User's Handbook* (Perkins part number 100816460).

---

<b>Perkins 400 Series User's Handbook</b>	
Genie part number	97360

---

### E-3 Perform Engine Maintenance - Perkins 403C-11 Models



Engine specifications require that this procedure be performed every 3000 hours.

Required maintenance procedures and additional engine information is available in the *Perkins 400 Series User's Handbook* (Perkins part number 100816460).

---

<b>Perkins 400 Series User's Handbook</b>	
Genie part number	97360

---

### E-4 Perform Generator Maintenance - Marathon Models



Generator specifications require that this procedure be performed every 10,000 hours.

Required maintenance procedures and additional generator information is available in the *Marathon Generator Service Manual* (Marathon part number SM301).

---

<b>Marathon Generator Service Manual</b>	
Genie part number	150109

---

### E-5 Perform Generator Maintenance - Leroy Somer Models



Generator specifications require that this procedure be performed every three years.

Required maintenance procedures and additional engine information is available in the *Leroy Somer Installation and Maintenance Manual* (Leroy Somer part number 1903-4.33).

---

<b>Leroy Somer Installation and Maintenance Manual</b>	
Genie part number	150138

---

# Repair Procedures



## Observe and Obey:

- ☑ Repair procedures shall be completed by a person trained and qualified on the repair of this machine.
- ☑ Immediately tag and remove from service a damaged or malfunctioning machine.
- ☑ Repair any machine damage or malfunction before operating the machine.

## Before Repairs Start:

- ☑ Read, understand and obey the safety rules and operating instructions in the appropriate operator's manual on your machine.
- ☑ Be sure that all necessary tools and parts are available and ready for use.
- ☑ Use only Genie approved replacement parts.
- ☑ Read each procedure completely and adhere to the instructions. Attempting shortcuts may produce hazardous conditions.
- ☑ Unless otherwise specified, perform each repair procedure with the machine in the following configuration:
  - Machine parked on a firm, level surface
  - Mast in the stowed position
  - Key switch in the off position
  - Light switches in the off position
  - Wheels chocked

## About This Section

Most of the procedures in this section should only be performed by a trained service professional in a suitably equipped workshop. Select the appropriate repair procedure after troubleshooting the problem.

Perform disassembly procedures to the point where repairs can be completed. Then to re-assemble, perform the disassembly steps in reverse order.

## Symbols Legend



Safety alert symbol—used to alert personnel to potential personal injury hazards. Obey all safety messages that follow this symbol to avoid possible injury or death.

### **▲ DANGER**

Indicates an imminently hazardous situation which, if not avoided, will result in death or serious injury.

### **▲ WARNING**

Indicates a potentially hazardous situation which, if not avoided, could result in death or serious injury.

### **▲ CAUTION**

Indicates a potentially hazardous situation which, if not avoided, may cause minor or moderate injury.

### **NOTICE**

Indicates a potentially hazardous situation which, if not avoided, may result in property damage.

⦿ Indicates that a specific result is expected after performing a series of steps.

⊗ Indicates that an incorrect result has occurred after performing a series of steps.

# Lighting

REV A

## 1-1 Lighting

### How to Remove a Lamp

**⚠ DANGER** High voltage. Exposure to electrical wires or electrical current will result in death or serious injury. Remove all rings, watches and other jewelry. Turn off all power when not needed for testing. Use extreme caution when working with high voltage electrical components.

**⚠ CAUTION** Burn hazard. Contact with hot lamp components may cause severe burns. Use caution when working around lamps.

- 1 Turn off all machine power.
- 2 Remove the light lens mounting fasteners and remove the lens.
- 3 Remove the mounting fasteners securing the lamp retainer to the reflector.

**NOTICE** Component damage hazard. Contacting the lamp with bare skin can cause damage to the lamp. Do not allow bare-skin contact with the lamps.

- 4 Wrap a clean cloth around the lamp and remove the lamp from the socket.

Note: Be sure to wrap a clean cloth around a lamp when installing a lamp into a lamp socket.

### How to Check Line Voltage

Correct line voltage at the lamp socket is essential for proper operation of the lighting system.

**⚠ DANGER** High voltage. Exposure to electrical wires or electrical current will result in death or serious injury. Remove all rings, watches and other jewelry. Turn off all power when not needed for testing. Use extreme caution when working with high voltage electrical components.

- 1 Turn off all machine power.
  - 2 Remove the cover from the lamp junction box.
- Note: The junction box is located between the light housings at the top of the mast.
- 3 Locate the correct wire for the lamp to be tested.
  - 4 Start the engine.
  - 5 Connect a voltmeter to the lamp wires.
  - 6 Turn the appropriate circuit breaker light switch to the on position.

REV A

LIGHTING

- 7 Observe the voltage as the lamps warm up.  
Refer to the following chart.

Note: It can take up to 5 minutes for the lights to reach full intensity. If the lights are turned off and then turned back on while they are still warm, they will not light up again for 10 to 20 minutes.

Time	Line Voltage
Initial ignition	427V AC
30 seconds	436V AC
1 minute	435V AC
2 minutes	431V AC
5 minutes	241V AC
10 minutes	No significant change

Note: If the voltage reading remains high during warm up, check for loose or broken wire connections OR the lamp may be faulty.

Note: The voltage readings provided in the chart are averages; voltage on your machine may vary.

## How to Check the Open Circuit Voltage

Correct line voltage at the lamp socket is essential for proper operation of the lighting system.

**⚠ DANGER** High voltage. Exposure to electrical wires or electrical current will result in death or serious injury. Remove all rings, watches and other jewelry. Turn off all power when not needed for testing. Use extreme caution when working with high voltage electrical components.

- 1 Turn off all machine power.
- 2 Remove the lamp. See 1-1, *How to Remove a Lamp*.
- 3 Install an adapter into the lamp socket.
- 4 With a voltmeter set to read 0-750V AC, connect the voltmeter leads to the lamp socket adapter.
- 5 Start the engine.
- 6 Turn the appropriate circuit breaker light switch to the on position and observe the reading on the voltmeter. Refer to the following chart.

### Voltage Specification

Lamp socket	400V AC to 445V AC
-------------	--------------------

Note: If there is no reading on the meter. Repair or replace the lamp socket, capacitor, ballast or wiring.

# Mast

REV A

## 2-1 Mast

### How to Remove the Mast Assembly

**⚠WARNING** Bodily injury hazard. The procedures in this section require specific repair skills, lifting equipment and a suitable workshop. Attempting this procedure without these skills and tools could result in death or serious injury and significant component damage. Dealer service is required.

- 1 Turn the handle of the mast pivot winch and loosen the mast pivot cable.
- 2 Remove the fasteners securing the cable pulley to the bottom of the mast and remove the pulley. Lay the cable to the side.

Note: Always replace the cotter pin with a new one when removing the pulley.

- 3 Tag and disconnect the mast wire harness connector from the machine at the firewall adjacent to the generator. Release the wire harness from the engine cover.
- 4 Attach a lifting strap from an overhead crane to the mast. Support the mast. Do not apply any lifting pressure.
- 5 Unlock the mast hold-down pin at the mast cradle.
- 6 Remove the mast pivot fasteners, securing the lower end of the mast to the machine, and remove the mast from the machine.

### How to Disassemble the Mast

- 1 Remove the mast assembly. See 2-1, *How to Remove the Mast Assembly*.
- 2 Remove the guide pad from the top of the number 2 mast tube.

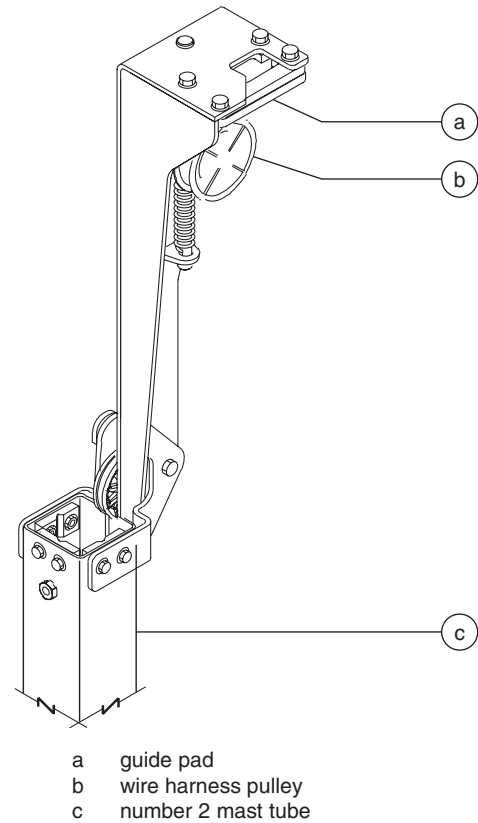

- 3 Remove the lighting wire harness from the number 1 mast tube.

REV A

MAST

- 4 Remove the light bar mounting fasteners. Remove the light bar and number 4 mast tube from the mast assembly and set them to the side.

**NOTICE** Component damage hazard. Cables can be damaged if they are kinked or pinched.

- 5 Remove the fasteners securing the number 3 lift cable to the top of the number 1 mast tube.
- 6 Remove the fasteners securing the cable pulley to the top of the number 2 mast tube. Remove the pulley from the mast and set it to the side.

Note: Always replace the cotter pin with a new one when removing the pulley.

- 7 Pull the number 2 mast tube approximately 12 inches / 30 cm out of number 1 mast tube.
- 8 Remove the inner wear pads from the top of the number 2 mast tube.
- 9 Remove the number 3 mast tube and cable from the mast assembly and set it to the side.

Note: If replacing the number 3 lift cable, remove the cable from the mast.

Note: To ensure that the mast extends properly after reassembly, carefully measure the cable to be sure the new cable is the same length as the old one.

- 10 Remove the cable retaining fastener securing the cable to the winch drum. Unwind the cable from the winch drum.

**CAUTION** Bodily injury hazard. Cables can fray. Always wear adequate hand protection when handling the cable.

- 11 Remove the inner wear pads from the top of the number 1 mast tube.
- 12 Remove the number 2 mast tube from the mast assembly and set it to the side.

Note: If replacing the number 2 lift cable, remove the cable from the mast.

Note: To ensure that the mast extends properly after reassembly, carefully measure the cable to be sure the new cable is the same length as the old one.

MAST

REV A

## How to Replace the Mast Lift Cable

See 2-1, *How to Disassemble the Mast*.

## How to Disassemble the Winch

Note: For ease of disassembly, refer to the illustration on the next page.

- 1 Lower the mast to the stowed position.
- 2 Remove the cable retaining fastener securing the cable to the winch drum. Unwind the cable from the winch drum.

**CAUTION** Bodily injury hazard. Cables can fray. Always wear adequate hand protection when handling the cable.

- 3 Remove the winch from the machine.
- 4 On a workbench, remove the handle, handle nut and two jam nuts from the pinion shaft.
- 5 Remove the retaining ring from the small groove at the non-threaded end of the pinion shaft. Rotate the pinion shaft until the shaft is removed. Hold the winch components in place while removing the pinion shaft.
- 6 Remove the cable drum.
- 7 Remove the ratchet pawl assemblies.
- 8 Remove the pinion shaft bushings. Use a soft metal drift equal to the outside diameter of the bushing and tap with a rubber mallet.

Note: Note the quantity and location of the shims between the winch drum and the bushing before disassembling.



REV A

MAST

## How to Assemble the Winch

- 1 Clean and inspect the winch components before installing.
- 2 Install the pinion shaft bushings. Use a soft metal drift equal to the outside diameter of the bushing and tap with a rubber mallet until fully seated.
- 3 Apply a small amount of lithium grease to the large threaded section of the pinion shaft.
- 4 Insert the pinion shaft through the small bushing in the winch frame, the pinion gear, friction disc ratchet gear, and finally through the large bushing at the other side of the frame. Refer to the illustration below.

**NOTICE** Component damage hazard. Grease or oil on the friction disc will result in poor winch performance. Do not allow grease or oil onto the friction disk.

- 5 Install the retaining ring into the small groove at the non-threaded end of the pinion shaft.

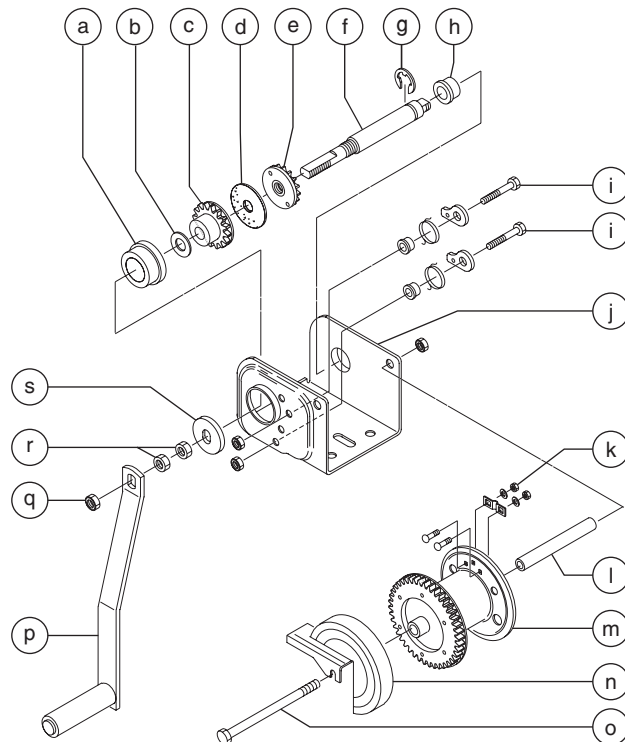

- 6 Install the ratchet pawl kit as shown in the illustration. Securely tighten the fasteners.
- 7 Insert the drum bolt through the frame spacer and the winch drum. Install and securely tighten the locknut.
- 8 Working from the threaded end of the pinion shaft, turn the shaft in a clockwise direction until the retaining ring, installed in step 5, is against the winch frame.
- 9 Install the thrust washer and pinion plate onto the pinion shaft.
- 10 Install the two jam nuts onto the pinion shaft and tighten.

**NOTICE** Component damage hazard. Be sure the pinion shaft is threaded all the way into the winch drum before tightening the two jam nuts.

- 11 Install the handle onto the winch. Install the handle nut onto the winch and securely tighten.
- 12 Route the cable onto the winch drum and install the cable retaining fasteners. Wind the cable onto the drum

**CAUTION** Bodily injury hazard. Cables can fray. Always wear adequate hand protection when handling the cable.

Note: Be sure the end of the cable does not extend past the edge of the winch drum.

- a pinion shaft bushing - large
- b thrust washer
- c ratchet gear
- d friction disc
- e pinion gear
- f pinion shaft
- g retaining ring
- h pinion shaft bushing - small
- i ratchet pawl assembly
- j winch frame
- k cable keeper kit
- l frame spacer
- m cable drum
- n cable drum cover
- o drum bolt
- p winch handle
- q handle nut
- r jam nut
- s pinion plate



# Chassis

REV A

## 3-1 Ground Controls

### How to Check a Lighting Capacitor

**⚠ DANGER** High voltage. Exposure to electrical wires or electrical current will result in death or serious injury. Remove all rings, watches and other jewelry. Turn off all power when not needed for testing. Use extreme caution when working with high voltage electrical components.

**⚠ DANGER** Electrocutation hazard. Attempting to service the machine before the capacitors are fully discharged will result in death or serious injury.

Note: Be sure the engine has been turned off for at least 15 minutes before servicing the machine. Use a voltmeter to confirm there is no residual voltage in the capacitors.

Note: This procedure is only for the capacitors which are attached to the lighting ballasts. To test a generator capacitor, see 4-1, *How to Check a Generator Capacitor*.

- 1 Remove the front access cover next to the machine control panel.
- 2 Tag and disconnect the four transformer harness connectors from the machine wire harness.

- 3 Using an insulated conductor or a screwdriver with an insulated handle, discharge each of the four capacitors by shorting across the capacitor terminals.

**⚠ DANGER** High voltage. Exposure to electrical wires or electrical current will result in death or serious injury. Remove all rings, watches and other jewelry. Use extreme caution when working with high voltage electrical components.

- 4 If equipped, tag and disconnect the external resistor from the capacitor.
- 5 With an ohmmeter set to its highest resistance scale, connect the ohmmeter leads to the capacitor terminals and observe the reading on the meter. Then, reverse the connections and observe the reading on the meter.
  - ⊙ Result: **Models with external resistor:** The meter indicates a very low resistance which then gradually increases AND a very high resistance which then gradually decreases. The capacitor is working.
  - ⊙ Result: **Models with internal resistor:** The meter indicates a resistance which then gradually decreases. The capacitor is working.
  - ⊗ Result: The meter indicates a very high resistance which does not decrease. The capacitor is faulty and should be replaced.
  - ⊗ Result: The meter indicates a very low resistance which does not increase. The capacitor is faulty and should be replaced.

Probable causes of capacitor failure:

- Normal end-of-life failure.
- Overheated due to fixture heat or high ambient temperature.
- Capacitor heat barrier removed.
- Incorrect capacitor voltage rating.

REV A

CHASSIS

## How to Check a Ballast

**⚠ DANGER** High voltage. Exposure to electrical wires or electrical current will result in death or serious injury. Remove all rings, watches and other jewelry. Turn off all power when not needed for testing. Use extreme caution when working with high voltage electrical components.

**⚠ DANGER** Electrocutation hazard. Attempting to service the machine before the capacitors are fully discharged will result in death or serious injury.

Note: Be sure the engine has been turned off for at least 15 minutes before servicing the machine. Use a voltmeter to confirm there is no residual voltage in the capacitors.

- 1 Tag and disconnect the four transformer harness connectors from the machine wire harness.

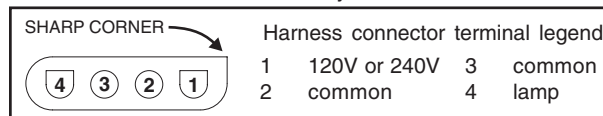
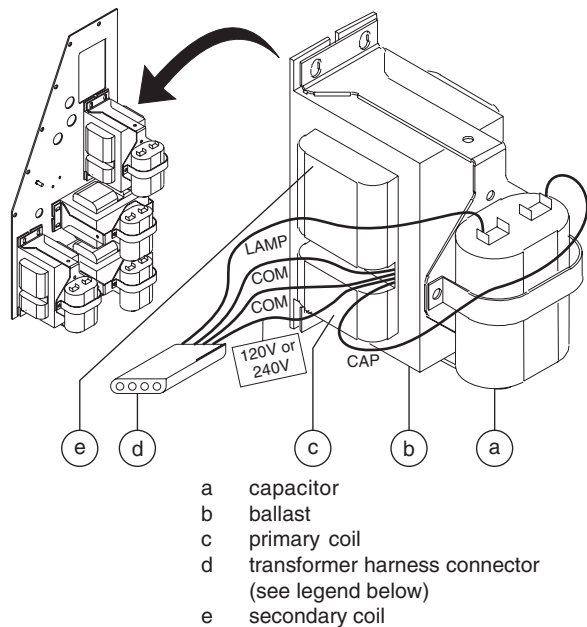

- 2 Using an insulated conductor or a screwdriver with an insulated handle, discharge each of the four capacitors by shorting across the capacitor terminals.

**⚠ DANGER** High voltage. Exposure to electrical wires or electrical current will result in death or serious injury. Remove all rings, watches and other jewelry. Use extreme caution when working with high voltage electrical components.

### Primary (input) coil resistance

- 3 With a multimeter set to read ohms, connect the multimeter leads to terminal 1 and 2 of the transformer harness connector and observe the reading on the meter.

⊙ Result: **Before serial number TML02-522 (with 120V AC ballast):** The meter shows ~0.4Ω to 0.6Ω resistance.

⊙ Result: **After serial number TML02-521 (with 240V AC ballast):** The meter shows ~0.8Ω to 0.9Ω resistance.

⊗ Result: There is no resistance or infinite resistance. The ballast is faulty and must be replaced.

### Secondary (output) coil resistance

- 4 With a multimeter set to read ohms, connect the multimeter lead to terminal 3 of the transformer harness connector.

- 5 Tag and disconnect the transformer wire lead from the capacitor and connect it to the other multimeter lead and observe the reading on the meter.

⊙ Result: The meter shows ~1.8Ω to 1.9Ω resistance.

⊗ Result: There is no resistance or infinite resistance. The ballast is faulty and must be replaced.



## CHASSIS

REV A

## How to Remove the Glow Plug Timer Circuit Board

- 1 Turn off all machine power.
- 2 Remove the fasteners securing the inspection panel to the chassis.

**⚠ DANGER** High voltage. Exposure to electrical wires or electrical current will result in death or serious injury. Remove all rings, watches and other jewelry. Turn off all power when not needed for testing. Use extreme caution when working with high voltage electrical components.

Note: Be sure the engine has been turned off for at least 15 minutes before servicing the machine. Use a voltmeter to confirm there is no residual voltage in the capacitors.

Note: The inspection panel is located next to the ground control panel.

- 3 Locate the glow plug circuit board behind the ground control panel.
- 4 Tag and disconnect the wire harness connector from the circuit board.
- 5 Carefully remove the retaining fastener and remove the circuit board from the machine.

## How to Remove the Fuel Tank

**⚠ DANGER** Explosion and fire hazard. Engine fuels are combustible. Remove the fuel tank in an open, well-ventilated area away from heaters, sparks, flames and lighted tobacco. Always have an approved fire extinguisher within easy reach.

**⚠ DANGER** Explosion and fire hazard. Never drain or store fuel in an open container due to the possibility of fire.

**⚠ DANGER** Explosion and fire hazard. When transferring fuel, connect a grounding strip between the machine and container.

- 1 Raise the mast to the fully vertical position.
- 2 Loosen the wire harness retainer at the chassis top cover.
- 3 Remove the fasteners securing the top cover to the chassis and remove the cover from the machine.
- 4 Remove the fasteners securing the fuel tank to the chassis.
- 5 Remove the supply hoses from the fuel tank and allow all of the fuel from the tank to drain into a suitable container. Refer to Section 2, *Specifications*.

Note: Be sure to clean up any fuel which may have spilled.

- 6 Plug the supply hoses and remove the fuel tank from the machine.

# Generator

REV A

## 4-1 Generator

### How to Remove the Generator Capacitor Cover

**▲ DANGER** High voltage. Exposure to electrical wires or electrical current will result in death or serious injury. Remove all rings, watches and other jewelry. Turn off all power when not needed for testing. Use extreme caution when working with high voltage electrical components.

Note: Be sure the engine has been turned off for at least 15 minutes before servicing the machine. Use a voltmeter to confirm there is no residual voltage in the capacitors.

- 1 Loosen but do not remove the fasteners securing the capacitor cover to the top of the generator.

**▲ CAUTION** Burn hazard. Contact with hot engine components may cause severe burns. Use caution when working around a hot engine.

- 2 Pull the cover off the top of the generator just enough to access the wire harness where it connects to the generator.
- 3 Tag and disconnect the wires at the top of the generator. Remove the cover.

### How to Check a Generator Capacitor

**▲ DANGER** High voltage. Exposure to electrical wires or electrical current will result in death or serious injury. Remove all rings, watches and other jewelry. Turn off all power when not needed for testing. Use extreme caution when working with high voltage electrical components.

**▲ DANGER** Electrocutation hazard. Attempting to service the machine before the capacitors are fully discharged will result in death or serious injury.

Note: Be sure the engine has been turned off for at least 15 minutes before servicing the machine. Use a voltmeter to confirm there is no residual voltage in the capacitors.

Note: This procedure is only for the capacitors which are attached to the generator. To test a lighting capacitor, see 3-1, *How to Check a Lighting Capacitor*.

- 1 Remove the generator capacitor cover. See 4-1, *How to Remove the Generator Capacitor Cover*.
- 2 Tag and disconnect the wires attached to the capacitor(s).

## GENERATOR

REV A

- 3 Using an insulated conductor or a screwdriver with an insulated handle, discharge the capacitor by shorting across the capacitor terminals. Repeat for the second capacitor, if equipped.

**⚠ DANGER** High voltage. Exposure to electrical wires or electrical current will result in death or serious injury. Remove all rings, watches and other jewelry. Use extreme caution when working with high voltage electrical components.

- 4 With an ohmmeter set to its highest resistance scale, connect the ohmmeter leads to the capacitor terminals and observe the reading on the meter. Then, reverse the connections and observe the reading on the meter.

- ⊙ Result: The meter indicates a very low resistance which then gradually increases AND a very high resistance which then gradually decreases. The capacitor is working.
- ⊗ Result: The meter indicates a very high resistance which does not decrease. The capacitor is faulty and should be replaced.
- ⊗ Result: The meter indicates a very low resistance which does not increase. The capacitor is faulty and should be replaced.

Probable causes of capacitor failure:

- Normal end-of-life failure.
- Overheated due to fixture heat or high ambient temperature.
- Capacitor heat barrier removed.
- Incorrect capacitor voltage rating.

Note: After shorting out the capacitor, it will be necessary to recharge it before starting the machine. To recharge the capacitor, connect the leads from a 6V DC battery to the leads of the capacitor for 1 second.

REV A

GENERATOR

## How to Remove the Generator

**⚠ DANGER** High voltage. Exposure to electrical wires or electrical current will result in death or serious injury. Remove all rings, watches and other jewelry. Turn off all power when not needed for testing. Use extreme caution when working with high voltage electrical components.

Note: Be sure the engine has been turned off for at least 15 minutes before servicing the machine. Use a voltmeter to confirm there is no residual voltage in the capacitors.

### Models with Lombardini or Deutz engine:

- 1 Remove the fuel tank. See 3-1, *How to Remove the Fuel Tank*.
  - 2 **Models with over-engine exhaust:** Remove the fasteners securing the exhaust pipe to the engine. Remove the exhaust pipe from the machine.
  - 3 Loosen but do not remove the fasteners securing the capacitor cover to the top of the generator.
- ⚠ CAUTION** Burn hazard. Contact with hot engine components may cause severe burns. Use caution when working around a hot engine.
- 4 Pull the cover off the top of the generator just enough to access the wire harness where it connects to the generator.

- 5 Using an insulated conductor or a screwdriver with an insulated handle, discharge the capacitor by shorting across the capacitor terminals. Repeat for the second capacitor, if equipped.

**⚠ DANGER** High voltage. Exposure to electrical wires or electrical current will result in death or serious injury. Remove all rings, watches and other jewelry. Use extreme caution when working with high voltage electrical components.

- 6 Tag and disconnect the wires at the top of the generator. Remove the cover.
- 7 Use a lifting jack to support the rear of the engine. Do not apply any lifting pressure.
- 8 Remove the generator fan screen from the generator.

Note: The generator fan screen covers the generator fan blades and is located between the generator and the engine bellhousing.

- 9 Remove the fasteners securing the generator to the engine flywheel.
- 10 Remove the fasteners securing the generator to the chassis.
- 11 Attach a lifting strap from an overhead crane to the generator. Support the generator. Do not apply any lifting pressure.
- 12 Remove the fasteners securing the generator to the engine bellhousing.
- 13 Remove the generator from the machine.

**⚠ CAUTION** Crushing hazard. The generator will fall if not properly supported when removed from the machine.

## GENERATOR

REV A

**Models with Perkins engine:**

- 1 Remove the fuel tank. See 3-1, *How to Remove the Fuel Tank*.
- 2 Loosen but do not remove the fasteners securing the capacitor cover to the top of the generator.

**CAUTION** Burn hazard. Contact with hot engine components may cause severe burns. Use caution when working around a hot engine.

- 3 Pull the cover off the top of the generator just enough to access the wire harness where it connects to the generator.
- 4 Using an insulated conductor or a screwdriver with an insulated handle, discharge the capacitor by shorting across the capacitor terminals. Repeat for the second capacitor, if equipped.

**DANGER** High voltage. Exposure to electrical wires or electrical current will result in death or serious injury. Remove all rings, watches and other jewelry. Use extreme caution when working with high voltage electrical components.

- 5 Tag and disconnect the wires at the top of the generator. Remove the cover.
- 6 Use a lifting jack to support the rear of the engine. Do not apply any lifting pressure.
- 7 Remove the fasteners securing the generator to the engine bellhousing.

- 8 Remove the fasteners securing the generator to the chassis.
- 9 Insert two pinch bars, equally spaced from each other, between the bellhousing and the generator. Gently tap them in between the bellhousing and generator.
- 10 Using equal pressure on both pinch bars, pull the bars towards the rear of the machine until the generator housing is  $\frac{3}{8}$  to  $\frac{1}{2}$  inch / 9 to 13 mm away from the engine bellhousing.

Note: It may be easier to open the gap by using larger bars after achieving some initial clearance.

- 11 Remove the fasteners securing the generator to the engine flywheel.
- 12 Attach a lifting strap from an overhead crane to the generator. Support the generator. Do not apply any lifting pressure.
- 13 Remove the generator from the machine.

**CAUTION** Crushing hazard. The generator will fall if not properly supported when removed from the machine.



REV A

GENERATOR

## How to Install the Generator

### Models with Lombardini or Deutz engine:

- 1 Remove the generator fan screen from the generator.
- 2 With the engine supported, install the generator onto the engine. Using a liquid threadlocker on the fastener threads, install the fasteners securing the generator to the engine bellhousing. Tighten to finger tight.
- 3 In a star pattern, torque the bellhousing fasteners to 30 ft-lbs / 20 Nm.
- 4 Using a liquid threadlocker on the fastener threads, install the fasteners securing the generator rotor to the engine flywheel. Tighten to finger tight.
- 5 In a star pattern, torque the flywheel fasteners to 15 ft-lbs / 41 Nm.
- 6 Install the fasteners securing the generator to the chassis. Securely tighten the fasteners.
- 7 Install the generator fan screen onto the generator. Install and securely tighten the retaining fasteners.
- 8 Install the wires onto the terminal block at the top of the generator. Securely tighten the fasteners.
- 9 Install the capacitor cover onto the generator. Install and securely tighten the fasteners.
- 10 **Models with over-engine exhaust:** Install the exhaust pipe into the muffler. Install and securely tighten all fasteners securing the exhaust pipe to the engine.
- 11 Install the fuel tank.

### Models with Perkins engine:

- 1 Using a liquid threadlocker on the fastener threads, install the armature drive plate and plate fasteners onto the engine flywheel. Install the fasteners to finger tight.
- 2 In a star pattern, torque the armature drive plate fasteners to 18 ft-lbs / 24 Nm.
- 3 Being careful to not damage the armature field windings, gently slide the generator housing over the armature until the rear armature race makes contact with the rear armature bearing.
- 4 Install four longer bolts through the generator housing and into the bellhousing equally spaced around the housing.

Note: These bolts will serve as a temporary guide while installing the generator housing onto the engine bellhousing.

- 5 Install four of the generator-to-flywheel fasteners to finger tight, equally spacing the fasteners around the generator. In a star pattern, tighten each bolt one-half turn at a time just until the generator housing evenly contacts the bellhousing.
- 6 Remove the long guide bolts.
- 7 Remove the generator housing fasteners.
- 8 Using a liquid threadlocker on the fastener threads, install the generator housing fasteners into the engine bellhousing. Install the fasteners to finger tight.
- 9 In a star pattern, torque the generator housing fasteners to 24 ft-lbs / 33 Nm.
- 10 Install the fasteners securing the generator to the chassis. Securely tighten the fasteners.
- 11 Install the wire harness onto the generator. Securely tighten the fasteners.
- 12 Install the capacitor cover onto the generator. Install and securely tighten the fasteners.

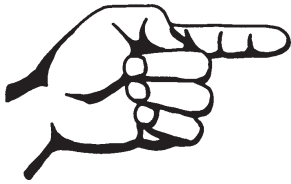

This page intentionally left blank.

# Troubleshooting



## Observe and Obey:

- ☑ Troubleshooting and repair procedures shall be completed by a person trained and qualified on the repair of this machine.
- ☑ Immediately tag and remove from service a damaged or malfunctioning machine.
- ☑ Repair any machine damage or malfunction before operating the machine.
- ☑ Unless otherwise specified, perform each repair procedure with the machine in the following configuration:
  - Machine parked on a firm, level surface
  - Mast in the stowed position
  - Key switch in the off position
  - Light switches in the off position
  - Wheels chocked

## Before Troubleshooting:

- ☑ Read, understand and obey the safety rules and operating instructions in the appropriate operator's manual on your machine.
- ☑ Be sure that all necessary tools and test equipment are available and ready for use.
- ☑ Be aware of the following hazards and follow generally accepted safe workshop practices.

**⚠ DANGER** Electrocutation hazard. Exposure to electrically charged circuits could result in death or serious injury. Remove all rings, watches and other jewelry.

**⚠ DANGER** Electrocutation hazard. Attempting to service the machine before the capacitors are fully discharged will result in death or serious injury.

**⚠ DANGER** High voltage. Exposure to electrical wires or electrical current will result in death or serious injury. Remove all rings, watches and other jewelry. Turn off all power when not needed for testing. Use extreme caution when working with high voltage electrical components.

**⚠ CAUTION** Burn hazard. Contact with hot lamp or engine components may cause severe burns. Use caution when working around lamps or a hot engine.

## TROUBLESHOOTING

## About This Section

When a malfunction is discovered, the fault code chart in this section will help a service professional pinpoint the cause of the problem. To use this section, basic hand tools and certain pieces of test equipment are required—voltmeter, ohmmeter, pressure gauges.

### General Repair Process

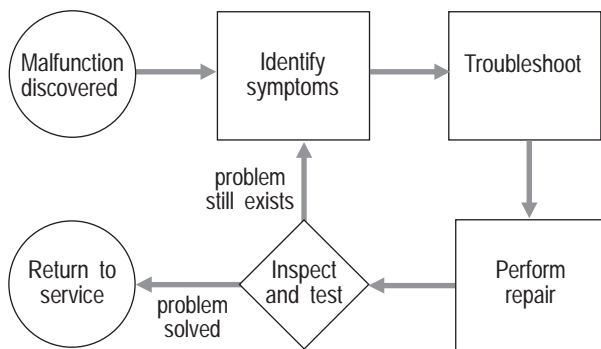

REV A

# Theory of Operation

The light system consists of four 1000W metal halide lamps mounted in reflective fixtures. Metal halide lamps are a specific type of lamp within the high intensity discharge (HID) lamp family. These HID lamps are powered by four "core and coil" or constant wattage autotransformer (CWA) type ballasts, which are mounted inside a secure compartment next to the ground control panel.

Generally, the ballast in a metal halide lighting system has two purposes:

- 1) To supply the proper starting voltage sufficient to strike and maintain the arc within the lamp, and
- 2) To supply the proper current to the lamp once the arc is established.

When using this type of ballast, a line voltage variation of  $\pm 10\%$  will result in a change in lamp wattage of similar proportions. Additionally, the ballast input current during lamp warm-up does not exceed the current when the lamp is stabilized.

At lamp start-up, the ballast produces a higher voltage of approximately twice the lamps voltage to initiate and maintain the arc. As the lamp temperature increases during warm-up, the voltage drops to the steady operating level. Metal halide lamps take from 2 to 5 minutes to warm-up and reach full lumen output. The following illustration shows how the voltage varies from lamp start-up to full lumen output.

An interruption in the power supply at any time or a sudden drop in voltage may cause the arc to extinguish. A lamp that is still hot will not restart until it has cooled enough to reduce vapor pressure within the arc tube to a point where the arc can restart, typically 10 to 20 minutes.

The incidences of accidental lamp outages tied to voltage dips is relatively low when using CWA type ballasts because the lamps can tolerate drops in line voltage of 30-40% before the lamp extinguishes.

### Lamp Voltage vs. Ignition Time

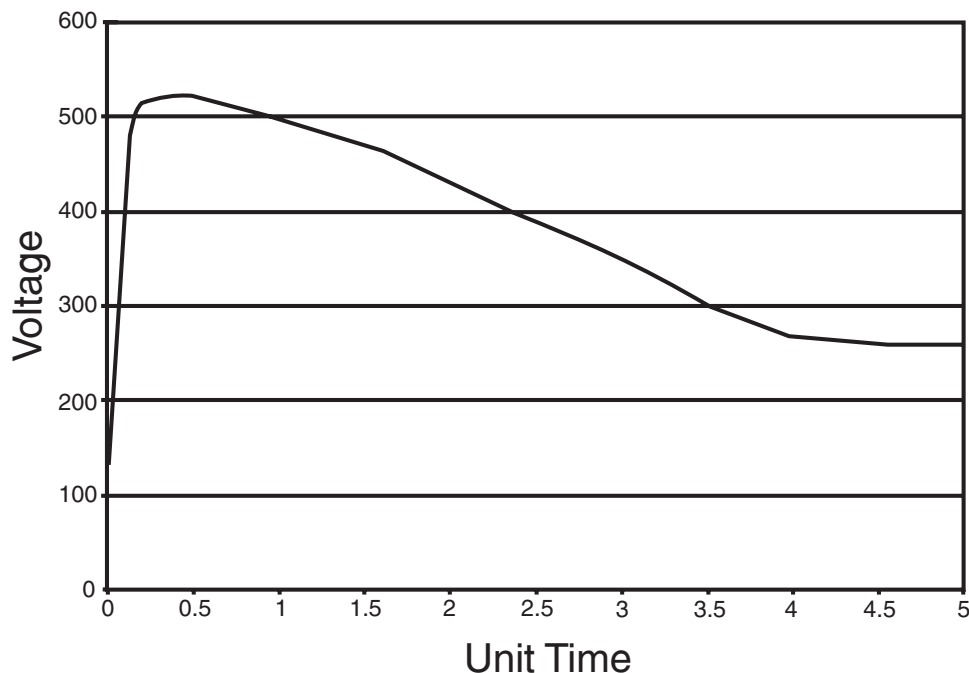

# Lamp Troubleshooting

REV A

Problem	Solution
Lamp will not start	Refer to Charts 1 through 8
Slow or erratic starting	Refer to Charts 1 through 10
Blinking or flickering	Refer to Charts 3, 9, 11 and 12
Cycling (lamps turn on and off)	Refer to Charts 1, 3, 5 and 9
Light output reduced	Refer to Charts 3, 4, 6 and 8
Short lamp life	Refer to Charts 1, 4, 13 and 14
Tripped circuit breaker	Refer to Charts 15, 16 and 17

Chart	Cause	Solution
1	Incorrect lamp or ballast	Check fixture label against lamp type
2	Lamp is improperly seated in socket	Remove and securely reinstall lamp. Confirm the pin connection in the lamp socket. Check the center contact of the socket for compression; if so, disconnect the fixture from power supply and carefully bend the contact into position with a screwdriver.
3	Incorrect or loose wiring	Disconnect from power supply and check all wiring and connections.
4	Lamp is at or near end of life	Replace with new lamp. <b>Metal Halide</b> lamps will produce low light output, may exhibit intermittent starting and suffer severe color changes. <b>High Pressure Sodium</b> lamps will exhibit normal starting but will turn off and on during operation (cycling), and may develop a brownish discoloration and a general blackening at the ends of the tube. <b>Low Pressure Sodium</b> lamps at nearly full light output but starting will become impossible at end of life. Check for blackening of the ends of the arc tube.
5	Line or ballast output voltage low	Check line voltage at the fixture. Check open circuit voltage.



REV A

LAMP TROUBLESHOOTING

<b>Chart</b>	<b>Cause</b>	<b>Solution</b>
6	Ballast burned out	Check circuit continuity. Replace capacitor at the same time.
7	Dirty or burned-out lamp	Visually inspect lamp for dirt or foreign materials. Visually inspect lamp for discoloration.
8	Improper ambient temperature	Metal halide lamps will start above -20°F. Other lamps experience starting problems when the ambient temperature is below 50°F.
9	Line voltage varies	Check incoming voltage with voltmeter. If this is the issue, check other equipment on the same circuit.
10	Hard-starting lamp	Replace with new lamp if delay is lengthy.
11	New lamp needs to be seasoned	Turn lamp on and off several times at 30-minute intervals
12	Significant air movement across lamps	Check for fans or air conditioning blowing across lamps.
13	Lamp operates less than 10 hours per start	Rated lamp life is based on 10 hours of operation per start. General rule for expected lamp life is that a 50% reduction in burn time per start results in a 25% reduction in lamp life.
14	Faulty Lamp	Replace with new lamp
15	Improper circuit breakers installed for fixture	Confirm that the circuit breakers match manufacturers specification.
16	Overloaded circuit	Verify that the total circuit load is less than circuit rating.
17	Shorted or grounded fixtures	Test for a short in the circuit. Replace faulty fixture.

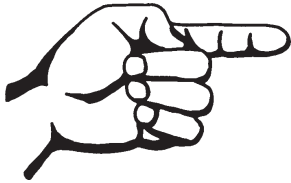

This page intentionally left blank.



# Schematics



## Observe and Obey:

- ☑ Troubleshooting and repair procedures shall be completed by a person trained and qualified on the repair of this machine.
- ☑ Immediately tag and remove from service a damaged or malfunctioning machine.
- ☑ Repair any machine damage or malfunction before operating the machine.

## Before Troubleshooting:

- ☑ Read, understand and obey the safety rules and operating instructions in the appropriate operator's manual on your machine.
- ☑ Be sure that all necessary tools and test equipment are available and ready for use.

## About This Section

There are two groups of schematics in this section. An illustration legend precedes each group of drawings.

### Electrical Schematics

**⚠ WARNING** Electrocutation hazard. Contact with electrically charged circuits could result in death or serious injury. Remove all rings, watches and other jewelry.

### Hydraulic Schematics

**⚠ WARNING** Bodily injury hazard. Spraying hydraulic oil can penetrate and burn skin. Loosen hydraulic connections very slowly to allow the oil pressure to dissipate gradually. Do not allow oil to squirt or spray.

### General Repair Process

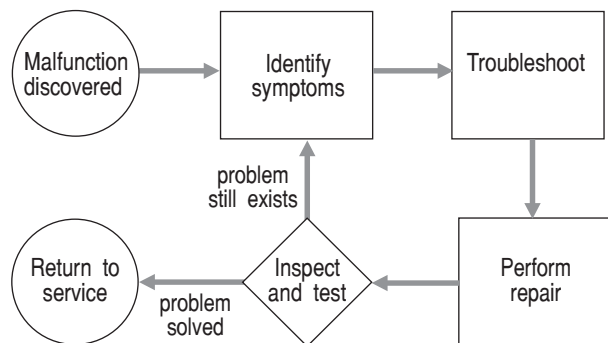

# Trailer Lighting Wiring Diagram

REV A

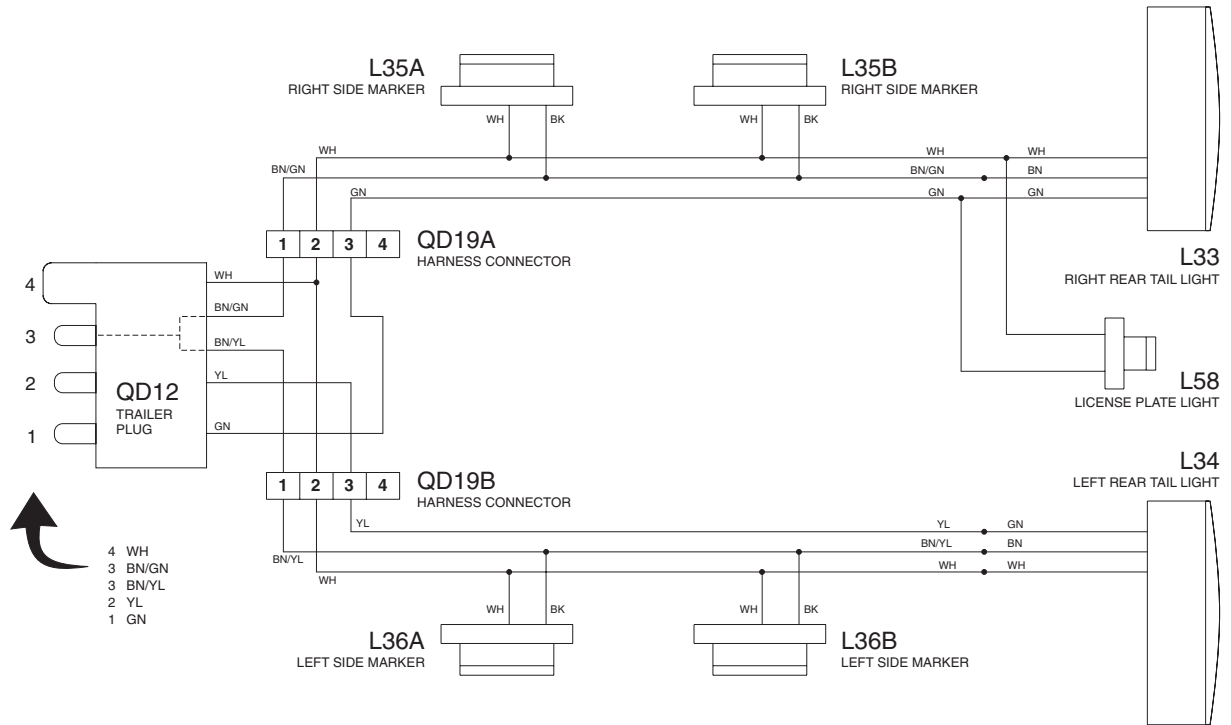

# Electrical Symbols Legend

REV A

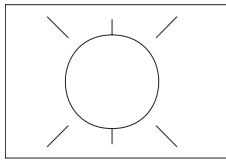

Lamp



Circuit breaker

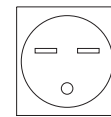
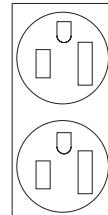
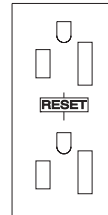

AC Outlet

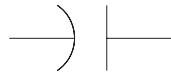

Capacitor



Switch

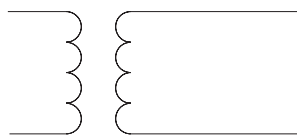

Transformer

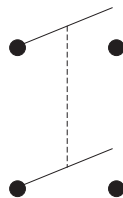

Switch

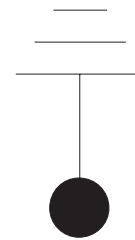

Ground

# Electrical Schematic

TML-4000N  
(before serial number TML02-522)

REV A

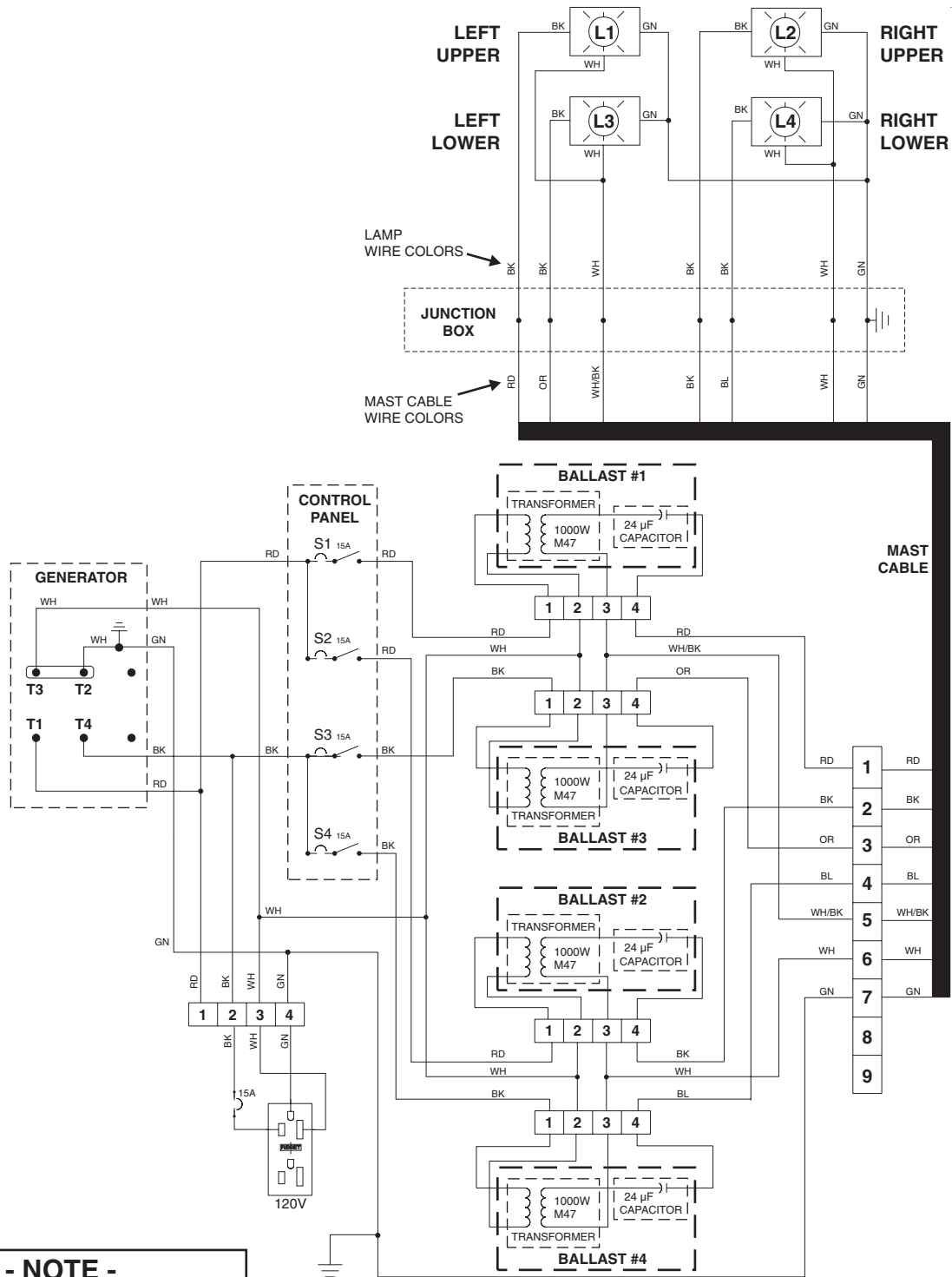

**- NOTE -**  
MACHINE SHOWN IN THE STOWED POSITION WITH THE POWER OFF



REV A

# Electrical Schematic

TML-4000  
(before serial number TML02-522)

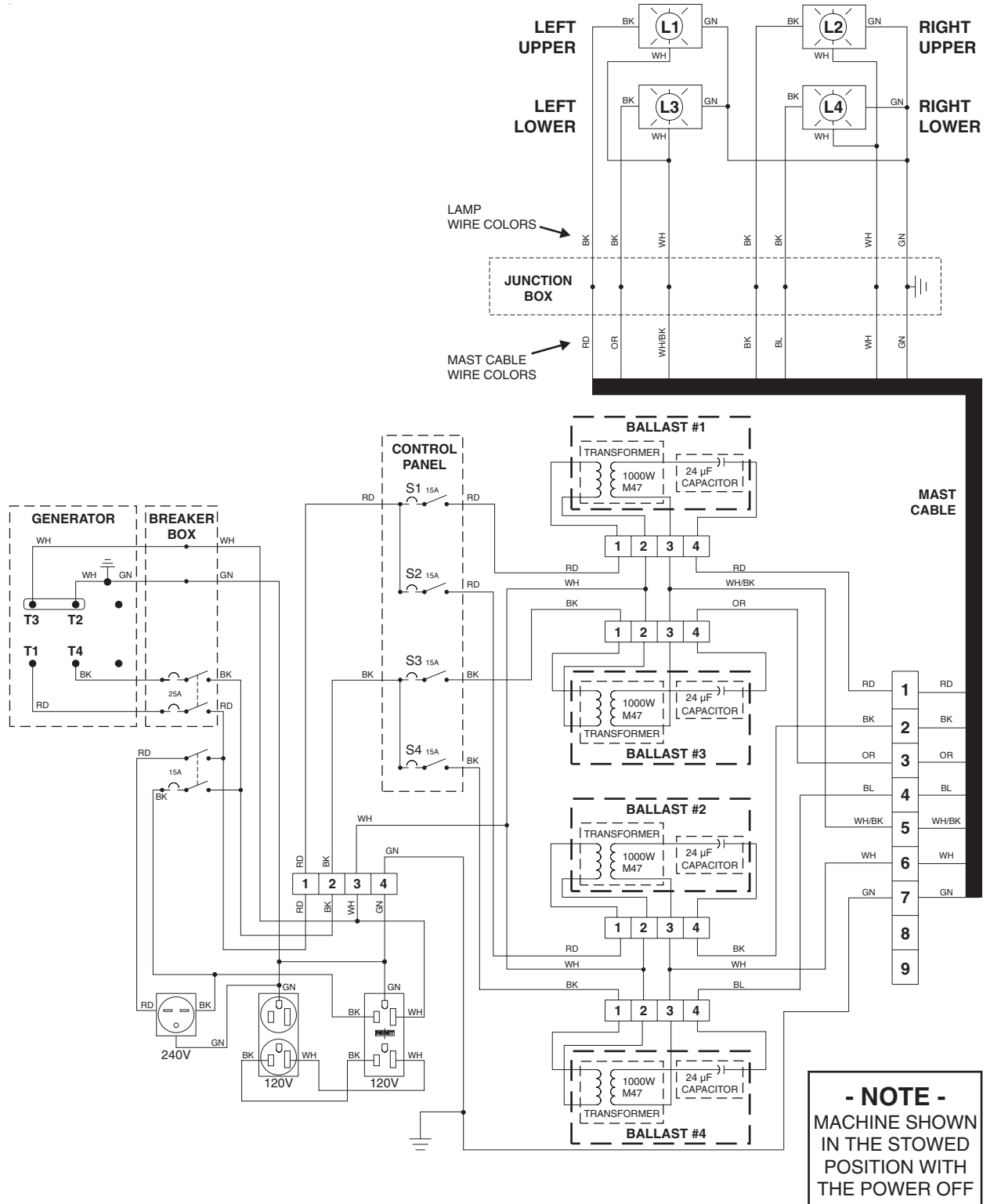

**- NOTE -**  
MACHINE SHOWN  
IN THE STOWED  
POSITION WITH  
THE POWER OFF



# Electrical Schematic

TML-4000 and TML-4000N  
(after serial number TML02-521)

REV A

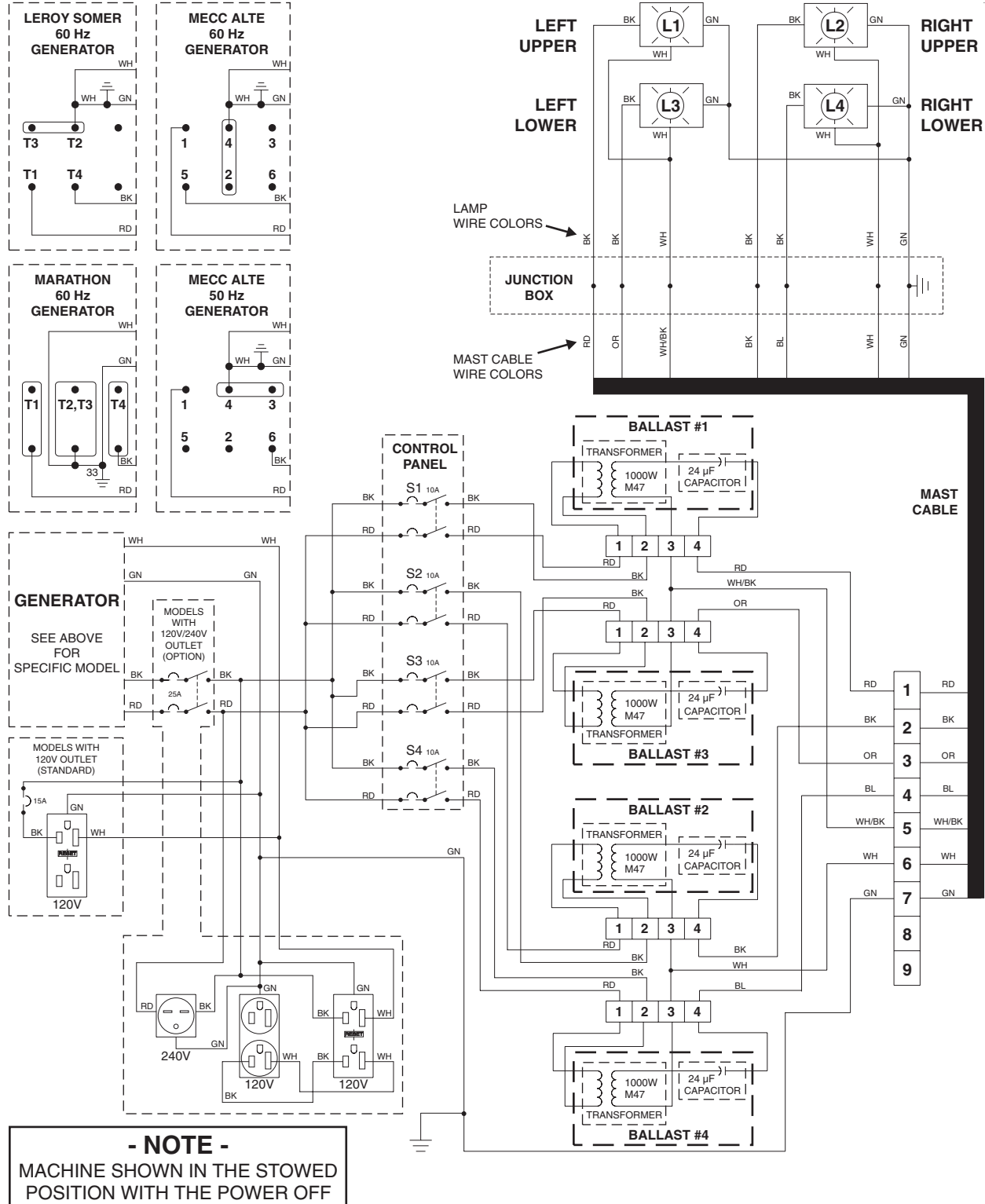

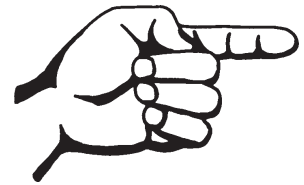

This page intentionally left blank.

# Electrical Schematic

Deutz Engine  
(before serial number TML05-213)

REV A

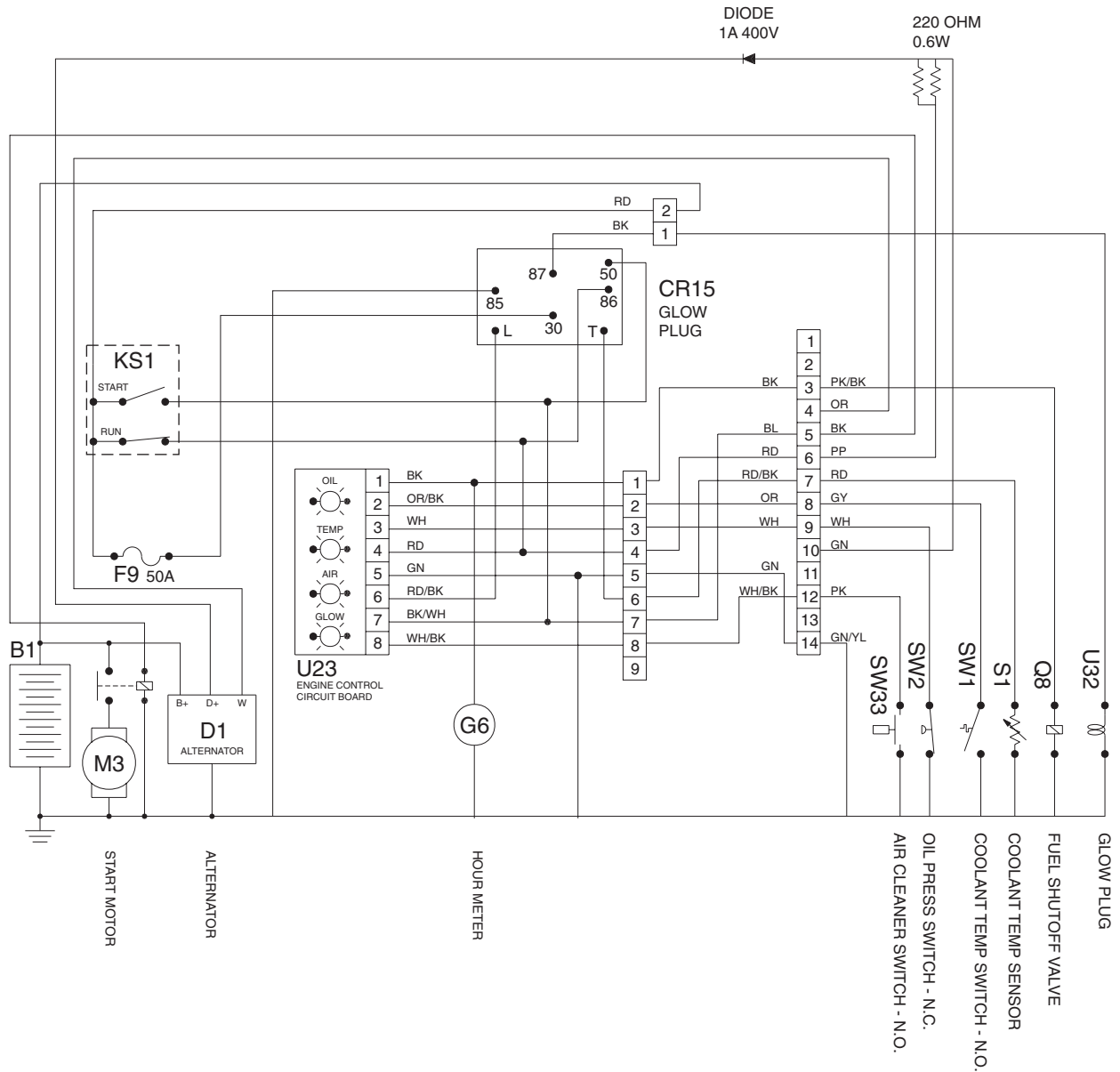

**- NOTE -**  
MACHINE SHOWN IN THE STOWED POSITION WITH THE POWER OFF





REV A

# Electrical Schematic

Lombardini and Deutz Engines  
(after serial number TML05-212)

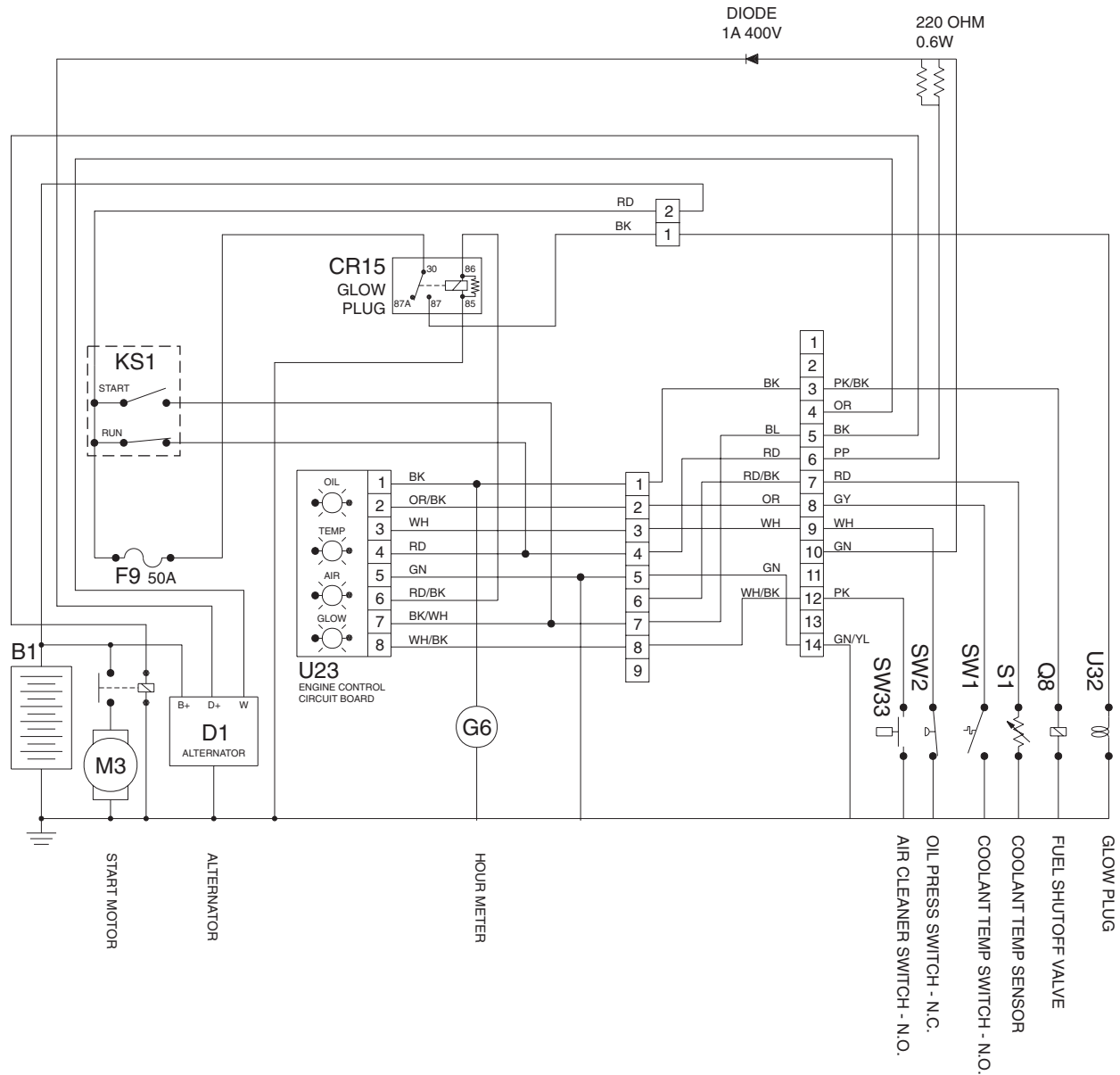

**- NOTE -**  
MACHINE SHOWN IN THE STOWED  
POSITION WITH THE POWER OFF



# Electrical Schematic

Perkins Engine  
(before serial number TML05-362)

REV A

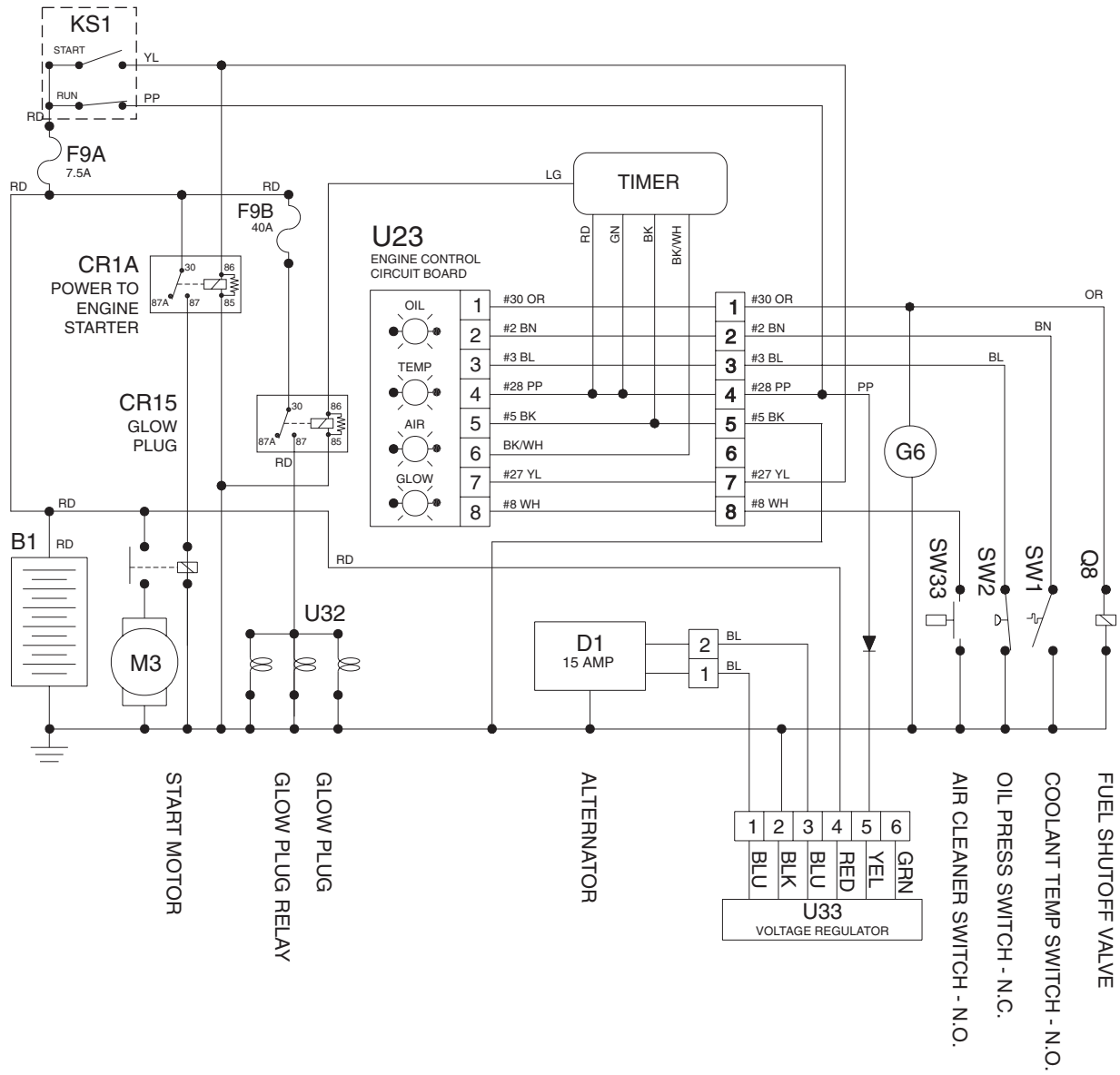

**- NOTE -**  
MACHINE SHOWN IN THE STOWED POSITION WITH THE POWER OFF



# Electrical Schematic

Perkins Engine

(after serial number TML05-361)

REV A

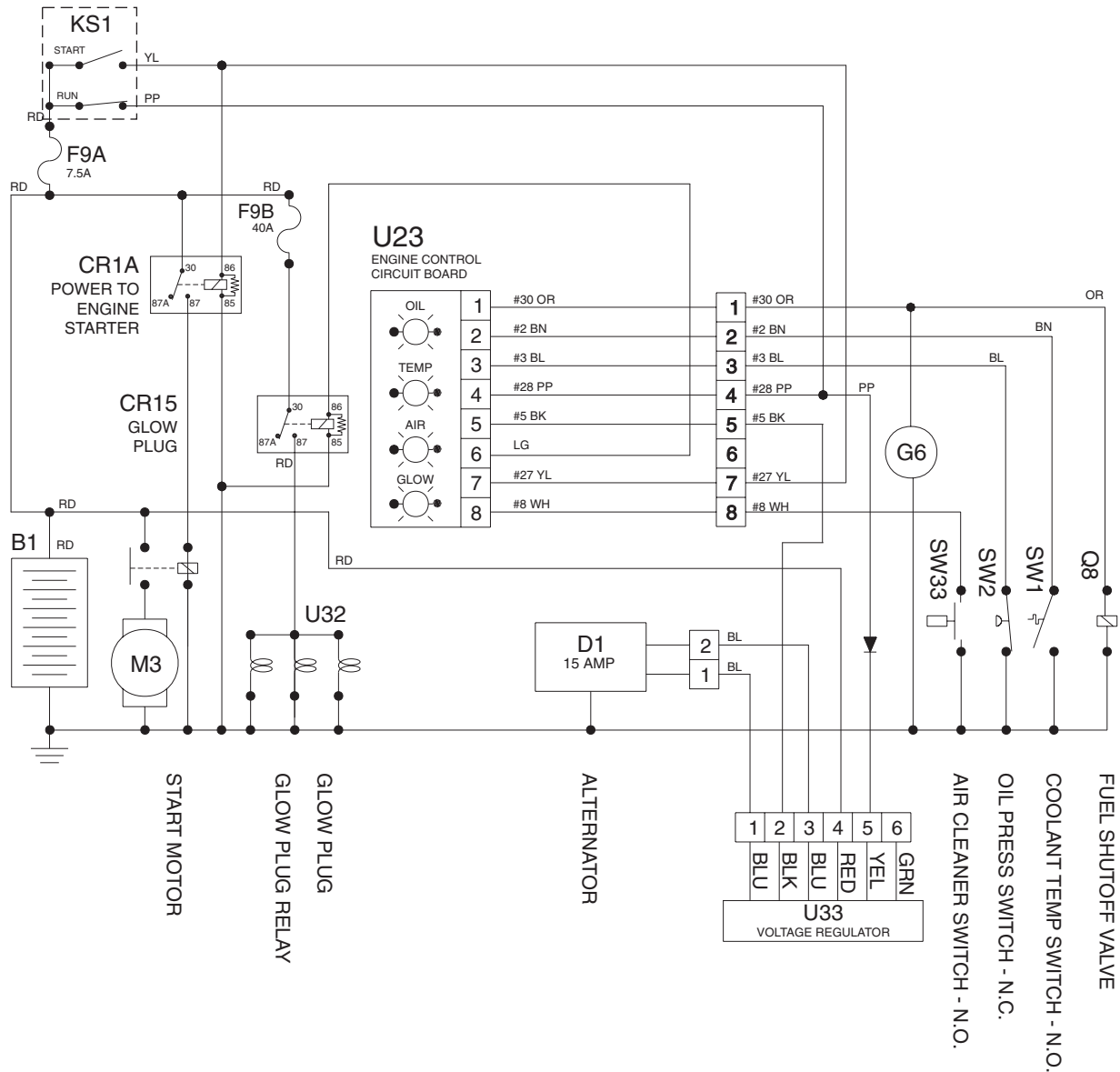

**- NOTE -**  
MACHINE SHOWN IN THE STOWED POSITION WITH THE POWER OFF



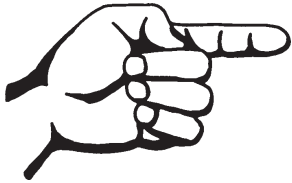

This page intentionally left blank.



California Proposition 65

## Warning

The exhaust from this product contains chemicals known to the State of California to cause cancer, birth defects or other reproductive harm.

## Towing Checklist

(Use at each stop)

### Before Towing

- Boom hold-down latch is securely locked in place
- Towing hitch is properly secured to tow vehicle
- Safety chains (if required) are properly attached and secure (chains are crossed below hitch)
- All lights are connected and working
- Tires are properly inflated

### Before Driving

- Fasten safety restraints
- Properly adjust mirrors

### On The Road

- Do not exceed 60 mph / 97 km/h. Obey all local and national towing speed laws
- Check connections and tire pressure at each stop
- Slow down for hazardous conditions
- Allow extra distance for following and passing other vehicles

Genie North America  
Phone 425.881.1800  
Toll Free USA and Canada  
800.536.1800  
Fax 425.883.3475

Genie Australia Pty Ltd.  
Phone +61 7 3375 1660  
Fax +61 7 3375 1002

Genie China  
Phone +86 21 53852570  
Fax +86 21 53852569

Genie Malaysia  
Phone +65 98 480 775  
Fax +65 67 533 544

Genie Japan  
Phone +81 3 3453 6082  
Fax +81 3 3453 6083

Genie Korea  
Phone +82 25 587 267  
Fax +82 25 583 910

Genie Brasil  
Phone +55 11 41 665 755  
Fax +55 11 41 665 754

Genie Holland  
Phone +31 183 581 102  
Fax +31 183 581 566

Genie Scandinavia  
Phone +46 31 575100  
Fax +46 31 579020

Genie France  
Phone +33 (0)2 37 26 09 99  
Fax +33 (0)2 37 26 09 98

Genie Iberica  
Phone +34 93 579 5042  
Fax +34 93 579 5059

Genie Germany  
Phone +49 (0)4202 88520  
Fax +49 (0)4202 8852-20

Genie U.K.  
Phone +44 (0)1476 584333  
Fax +44 (0)1476 584334

Genie Mexico City  
Phone +52 55 5666 5242  
Fax +52 55 5666 3241

Distributed By: