



Maintenance Manual - Telehandlers

GTH™-636
GTH™-844
GTH™-1056
GTH™-1256
GTH™-1544
GTH™-5519

Refer to the inside cover for a list of model serial number ranges included in this manual.

This manual includes detailed procedures for each maintenance inspection.

For Repair procedures, Fault Codes, Electrical and Hydraulic Schematics, refer to the appropriate Service and Repair Manual for your machine.

Original Instructions
Part No. 1272858GT
Rev B
November 2022

Introduction

Important

Read, understand and obey the safety rules and operating instructions in the appropriate Operator's Manual on your machine before attempting any maintenance procedure.

This manual provides detailed scheduled maintenance information for the machine owner and user.

Basic mechanical, hydraulic and electrical skills are required to perform most procedures. However, several procedures require specialized skills, tools, lifting equipment and a suitable workshop. In these instances, we strongly recommend that maintenance be performed at an authorized Genie dealer service center.

Compliance

Machine Design Life

Unrestricted with proper operation, inspection and scheduled maintenance.

Technical Publications

Genie has endeavored to deliver the highest degree of accuracy possible. However, continuous improvement of our products is a Genie policy. Therefore, product specifications are subject to change without notice.

Readers are encouraged to notify Genie of errors and send in suggestions for improvement. All communications will be carefully considered for future printings of this and all other manuals.

Contact Us:

Internet: www.genielift.com
E-mail: awp.techpub@terex.com

Copyright © 2016 by Terex Corporation

1272858GT Rev B, November 2022

First Edition, Second Printing

Genie is a registered trademark of Terex South Dakota, Inc. in the U.S.A. and many other countries.

"GTH" is a trademark of Terex South Dakota, Inc.

Introduction

Models included in this manual

Use the following chart to identify the specific serial number for models included in this manual.

Models	Serial number
GTH-636	from GTH0615H-10001 to 16H-10742 from GTH0615E-10000 to GTH0616E-10999 from GTH06E-11000 to GTH06E-13800
GTH-844	from GTH0813-16606 to GTH0816-21572 from GTH0816E-10000 to GTH0816E-10699 from GTH08E-10700 to GTH08E-14100
GTH-1056	from GTH1010-14001 to GTH1014-20404 from GTH1014E-10001 to GTH1016E-10799 from GTH10E-10800 to GTH10E-15999
GTH-1256	from GTH1215M-101 to GTH1216M-249 from GTH12M-250
GTH-1544	from GTH1513B-1 to 15B-339 (includes 24273)
GTH-5519	from GTH5514B-101 to GTH5516B-4411 from GTH5516M-4411 to GTH5516M-5799 from GTH55M-5800

Identifying the Correct Procedure for your Model

Unless otherwise noted, each procedure will apply to all models. Procedures that only apply to specific models or options will include the information in the procedure title.

Examples of procedures that apply to specific models:

- Adjust the Boom Sequencing Chains - **GTH-636 and GTH-844**
- Adjust the Boom Sequencing Chains - **GTH-1056**

Examples of procedures that apply to all models:

- Inspect the Electrical Wiring
- Inspect the Tires, Wheels and Lug Nut Torque

Find additional Manuals for your Model

Go to <http://www.genielift.com>

Use the links to locate Service Manuals, Maintenance Manuals, Service and Repair Manuals, Parts Manuals and Operator's Manuals.

Introduction

Revision History

Revision	Date	Section	Procedure / Description
A	3/2016		Initial Release
A1	9/2016	Introduction	Models Included
B	11/2022	Introduction	Models Included
Reference Examples:			<p style="text-align: center;">Electronic Version</p> <p>Click on any content or procedure in the Table of Contents to view the update.</p>
Section – Specifications			
Section – Maintenance, (procedure)			



Safety Rules



Danger

Failure to obey the instructions and safety rules in this manual and the appropriate Operator's Manual on your machine will result in death or serious injury.

Many of the hazards identified in the operator's manual are also safety hazards when maintenance and repair procedures are performed.

Do not modify or alter a MEWP without prior written permission from the manufacturer.

Do Not Perform Maintenance Unless:

- You are trained and qualified to perform maintenance on this machine.
- You read, understand and obey:
 - manufacturer's instructions and safety rules
 - employer's safety rules and worksite regulations
 - applicable governmental regulations
- You have the appropriate tools, lifting equipment and a suitable workshop.

Safety Rules

Personal Safety

Any person working on or around a machine must be aware of all known safety hazards. Personal safety and the continued safe operation of the machine should be your top priority.



Read each procedure thoroughly. This manual and the decals on the machine, use signal words to identify the following:



Safety alert symbol—used to alert personnel to potential personal injury hazards. Obey all safety messages that follow this symbol to avoid possible injury or death.



Indicates a imminently hazardous situation which, if not avoided, will result in death or serious injury.



Indicates a potentially hazardous situation which, if not avoided, could result in death or serious injury.



Indicates a potentially hazardous situation which, if not avoided, may cause minor or moderate injury.



Indicates a potentially hazardous situation which, if not avoided, may result in property damage.



Be sure to wear protective eye wear and other protective clothing if the situation warrants it.



Be aware of potential crushing hazards such as moving parts, free swinging or unsecured components when lifting or placing loads. Always wear approved steel-toed shoes.

Workplace Safety

Any person working on or around a machine must be aware of all known safety hazards. Personal safety and the continued safe operation of the machine should be your top priority.



Be sure to keep sparks, flames and lighted tobacco away from flammable and combustible materials like battery gases and engine fuels. Always have an approved fire extinguisher within easy reach.



Be sure that all tools and working areas are properly maintained and ready for use. Keep work surfaces clean and free of debris that could get into machine components and cause damage.



Be sure any forklift, overhead crane or other lifting or supporting device is fully capable of supporting and stabilizing the weight to be lifted. Use only chains or straps that are in good condition and of ample capacity.



Be sure that fasteners intended for one time use (i.e., cotter pins and self-locking nuts) are not reused. These components may fail if they are used a second time.



Be sure to properly dispose of old oil or other fluids. Use an approved container. Please be environmentally safe.



Be sure that your workshop or work area is properly ventilated and well lit.

Table of Contents

Introduction	Introduction..... ii
	Important Information ii
	Models included in this manual iii
	Identifying the Correct Procedure for your Model iii
	Find additional Manuals for your Model iii
	Revision History..... iv
Section 1	Safety Rules v
	General Safety Rules v
Section 2	Specifications 1
	Machine Specifications 1
	Air Conditioner Refrigerant Specifications 2
	Performance Specifications 3
	Performance Specifications..... 3
	Torque Specifications 5
	Tires and Wheels 5
	Powertrain Specifications 6
	Operator and Maintenance Manuals 6
	Deutz Engine Models 7
	John Deere Engine Models 7
	Perkins Engine Models 8
	Transmission Specifications 9
	Axle Specifications 10
	Hydraulic Specifications..... 11
	Hydraulic Relief Valves 11
	Hydraulic Oil Specifications..... 13
	Hydraulic Hose and Fitting Torque Specifications 16
	Torque Procedure 17



Table of Contents

Section 3	Maintenance Procedures	19
	Introduction	19
	Maintenance Schedule	21
	Pre-Delivery Preparation Report.....	22
	Scheduled and Programmed Maintenance Inspection Report	23
	Commissioning Procedures	24
	C-1 Perform 50 Hour Service.....	24
	C-2 Perform Engine Maintenance – 50 Hours.....	24
	C-3 Perform 150 Hour Service.....	25
	Quarterly Maintenance Procedures	26
	Q-1 Check for Open Bulletins and Owner Registration	26
	Q-2 Battery inspection	27
	Q-3 Inspect the Electrical Wiring.....	28
	Q-4 Check the Boom Wear Pads.....	29
	Q-5 Check the Exhaust System.....	31
	Q-6 Inspect the Tires, Wheels and Lug Nut Torque	31
	Q-7 Inspect the Fork Level and Auxiliary Hydraulic Hoses Tension.....	32
	Q-8 Inspect the Fuel and Hydraulic Tank Cap Venting Systems	32
	Q-9 Visual Inspection of the Hydraulic Oil	33
	Q-10 Inspect the Engine Air Filter.....	34
	Q-11 Lubricate the Driveshaft.....	35
	Q-12 Inspect and Lubricate the Sequencing Chains	35
	Annual Maintenance Procedures	38
	A-1 Inspect the Forks.....	38
	A-2 Adjust the Boom Sequencing Chains - GTH-636, GTH-844.....	38
	A-3 Adjust the Boom Sequencing Chains - GTH-1056.....	39
	A-4 Adjust the Boom Sequencing Chains - GTH-1256 and GTH-1544.....	40
	A-5 Replace Hydraulic Tank Return Filter Element	41
	A-6 Replace the Cab Air Intake Filter Element (if equipped).....	41

Table of Contents

Programmed Maintenance Procedures	42
P0-1 Lubricate the Boom.....	42
P0-2 Deutz Engine Maintenance – Under 1000 Hours	43
P0-3 Perkins Engine Maintenance – Under 1000 Hours	44
P0-4 John Deere Engine Maintenance – Under 1000 Hours.....	45
P0-5 Axle Maintenance – Under 1000 Hours.....	46
P0-6 Transmission Maintenance – Under 1000 Hours	48
P1-1 Perform Engine Maintenance – 1000 Hours	49
P1-2 Perform Transmission Maintenance – 1000 Hours	49
P1-3 Perform Axle Maintenance – 1000 Hours.....	50
P2-1 Perform Engine Maintenance – 2000 Hours	51
P2-2 Test or Replace the Hydraulic Oil	52
P3-1 Perform Engine Maintenance – 3000 Hours	53
P4-1 Perform Engine Maintenance – 4000 Hours	53
P6-1 Perform Engine Maintenance – 6000 Hours	54
P12-1 Perform Engine Maintenance – 12000 Hours	54



This page intentionally left blank.

Specifications

GTH-636

Fluid capacities

Fuel tank	27 gallons 102.2 liters
Hydraulic tank	34 gallons 128.7 liters
Hydraulic system (including tank)	46.5 gallons 176 liters

GTH-844 (to SN GTH0816-21535)

Fluid capacities

Fuel tank	35 gallons 132.5 liters
Hydraulic tank	40 gallons 151.4 liters
Hydraulic system (including tank)	55 gallons 208.2 liters

GTH-844 (from SN GTH0816-21536, GTH0816-10000)

Fluid capacities

Fuel tank	32 gallons 121.1 liters
Hydraulic tank	35 gallons 132.5 liters
Hydraulic system (including tank)	50 gallons 189.3 liters
DEF tank	2.6 gallons 10 liters

GTH-1056

Fluid capacities

Fuel tank	35 gallons 132.5 liters
Hydraulic tank	44 gallons 166.5 liters
Hydraulic system (including tank)	55 gallons 208.2 liters

GTH-1256, GTH-1544

Fluid capacities

Fuel tank	47 gallons 178 liters
Hydraulic tank	48 gallons 182 liters
Hydraulic system (including tank)	77 gallons 291 liters

GTH-5519

Fluid capacities

Fuel tank	15.9 gallons 60 liters
Hydraulic tank	16.4 gallons 62 liters
Hydraulic system (including tank)	25 gallons 95 liters

Specifications

Air Conditioner Refrigerant Specifications

System Full Charge	R134a
GTH-636, GTH-844 and GTH-1056	1 lb 14 oz
GTH-1256, GTH-1544	2 lb 3 oz
GTH-5519	1 lb 10 oz

Performance Specifications

GTH-636

Drive speed, maximum

Deutz TD2.9 Engines	18 mph 29.0 km/h
---------------------	---------------------

Draw bar pull	15,100 lbs 6849 kg
---------------	-----------------------

Lift capacity, maximum	6000 lbs 2722 kg
------------------------	---------------------

Boom function speeds, maximum

Boom up	10 to 12 seconds
---------	------------------

Boom down	8 to 10 seconds
-----------	-----------------

Boom extend	11 to 13 seconds
-------------	------------------

Boom retract	9 to 11 seconds
--------------	-----------------

Fork rotate	3 to 6 seconds
-------------	----------------

Fork tilt up	6 to 8 seconds
--------------	----------------

Fork tilt down	5 to 7 seconds
----------------	----------------

GTH-844

Drive speed, maximum

Deutz 3.6 TCD Engines	15 mph 24.1 km/h
-----------------------	---------------------

Perkins 1104D Engine	14 mph 22.5 km/h
----------------------	---------------------

Perkins 854 Engine	16 mph 25.7 mph
--------------------	--------------------

Draw bar pull	21,000 lbs 9525 kg
---------------	-----------------------

Lift capacity, maximum	8000 lbs 3629 kg
------------------------	---------------------

Boom function speeds, maximum

Boom up	12 to 14 seconds
---------	------------------

Boom down	9 to 11 seconds
-----------	-----------------

Boom extend	13 to 15 seconds
-------------	------------------

Boom retract	8 to 10 seconds
--------------	-----------------

Fork rotate	3 to 6 seconds
-------------	----------------

Fork tilt up	6 to 8 seconds
--------------	----------------

Fork tilt down	5 to 7 seconds
----------------	----------------

GTH-1056

Drive speed, maximum

All engines	19 mph 31.2 km/h
-------------	---------------------

Draw bar pull	22,900 lbs 10,387 kg
---------------	-------------------------

Lift capacity, maximum	10,000 lbs 4545 kg
------------------------	-----------------------

Boom function speeds, maximum

Boom up	12 to 14 seconds
---------	------------------

Boom down	9 to 11 seconds
-----------	-----------------

Boom extend	13 to 15 seconds
-------------	------------------

Boom retract	8 to 10 seconds
--------------	-----------------

Fork rotate	3 to 6 seconds
-------------	----------------

Fork tilt up	6.5 to 8.5 seconds
--------------	--------------------

Fork tilt down	6 to 8 seconds
----------------	----------------

GTH-1256

Drive speed, maximum

All engines	18 mph 29 km/h
-------------	-------------------

Draw bar pull	22,500 lbs 10,206 kg
---------------	-------------------------

Lift capacity, maximum	12,000 lbs 5450 kg
------------------------	-----------------------

Boom function speeds, maximum

Boom up	16 seconds
---------	------------

Boom down	13 seconds
-----------	------------

Boom extend	22 seconds
-------------	------------

Boom retract	15 seconds
--------------	------------

Fork tilt up	5 seconds
--------------	-----------

Fork tilt down	4 seconds
----------------	-----------

Performance Specifications

GTH-1544		GTH-5519	
Drive speed, maximum		Drive speed, maximum	
All engines	18 mph 29 km/h	All engines	16 mph 25.8 km/h
Draw bar pull	22,500 lbs 10,206 kg	Draw bar pull	9200 lbs 4173 kg
Lift capacity, maximum	15,000 lbs 6804 kg	Lift capacity, maximum	5,500 lbs 2,500 kg
Boom function speeds, maximum		Boom function speeds, maximum	
Boom up	19 seconds	Boom up	7 seconds
Boom down	15 seconds	Boom down	7 seconds
Boom extend	17 seconds	Boom extend	7 seconds
Boom retract	14 seconds	Boom retract	4 seconds
Fork tilt up	7 seconds	Fork tilt up	4 seconds
Fork tilt down	7 seconds	Fork tilt down	3 seconds

Torque Specifications

GTH-636

Lug nut torque	465 ft-lb 630 Nm
Tire pressure (models with air-filled tires)	58 psi 4.3 bar

GTH-844

Lug nut torque	465 ft-lb 630 Nm
Tire pressure (models with air-filled tires)	62 psi 4.3 bar

GTH-1056

Lug nut torque	465 ft-lb 630 Nm
Tire pressure (models with air-filled tires)	62 psi 4.27 bar

GTH-1256

Lug nut torque	465 ft-lb 630 Nm
Tire pressure (models with air-filled tires)	87 psi 6 bar

GTH-1544

Lug nut torque	465 ft-lb 630 Nm
Tire pressure (models with air-filled tires)	87 psi 6 bar

GTH-5519

Lug nut torque	295 ft-lb 400 Nm
Tire pressure (models with air-filled tires)	65 psi 4.5 bar

Powertrain Specifications

Engine Operator and Maintenance Manuals

Deutz TD 2.9 L4	
Genie part number	1251561
Deutz TCD3.6 L4	
Genie part number	218707
Deutz TCD 4.1 L4	
Genie part number	57.4700.0004
Perkins 854F-E34T	
Genie part number	218708
Perkins 1104D-E44TA	
Genie part number	117765
Perkins 1204E-E44TA	
Genie part number	218726
John Deere 4045TH485	
Genie part number	123703

Transmission Operator and Maintenance Manuals

Carraro 26.27M	
Genie part number	218710
Dana Integral Gear Box Shift on Fly	
Genie part number	57.4700.0007
Dana T20000	
Genie part number	115025
Dana VDT12000	
Genie part number	218706
ZF 4 WG-98 TC	
Genie part number	1258405

Axle Operator and Maintenance Manuals

Comer	
Genie part number	57.4700.0020
Dana 212	
Genie part number	1259569
Dana Planetary 213	
Genie part number	115026

Powertrain Specifications

Deutz Engine Models

TD 2.9 L4, GTH-636

Standby idle	1000 rpm
Low idle	950 rpm
High idle	2600 rpm
Oil capacity (including filter)	9.4 quarts
Units ship with 15W-40.	9 liters
Engine coolant capacity	12.4 quarts
Type: Extended Life 50/50	11.7 liters

TD 2.9 L4, GTH-5519

Low idle	1000 rpm
High idle	2700 rpm
Oil capacity (including filter)	8.5 quarts 8 liters
Units ship with 15W-40 Shell Rimula R4 L.	
Engine coolant capacity	3.3 gallons
Type: Extended Life	12.5 liters

TCD 3.6 L4, GTH-844, GTH-1056

Low idle	1000 rpm
High idle	2400 rpm
Oil capacity (including filter)	9.5 quarts 9 liters
Units ship with 15W-40 API CJ4 low ash oil.	
Engine coolant capacity	4.5 gallons
Type: Extended Life	17 liters

TCD 4.1 L4, GTH-1256, GTH-1544

Low idle	920 rpm
High idle	2300 rpm
Oil capacity (including filter)	12.1 quarts 11.5 liters
Units ship with 15W-40 API CJ4 low ash oil.	
Engine coolant capacity	7.6 gallons
Type: Ethylene Glycol	29 liters

Extreme operating temperatures may require the use of alternative engine oils. For oil requirements, refer to the Engine Operator Manual for your engine.

John Deere Engine Models

4045HF485, GTH-1056

Low idle	8000 rpm
High idle	2400 rpm
Oil capacity (including filter)	14 quarts 13.2 liters
Oil type	15W-40
Units ship with John Deere Engine Break-In Oil. During the break-in period, add John Deere Engine Break-In Oil as needed to maintain the specified oil level.	
Engine coolant capacity	7 gallons
Type: Extended Life	26.5 liters

Extreme operating temperatures may require the use of alternative engine oils. For oil requirements, refer to the Engine Operator Manual for your engine.

Powertrain Specifications

Perkins Engine Models

854E-E34TA, GTH-844

Low idle	1000 rpm
High idle	2700 rpm
Oil capacity (including filter)	8.8 quarts 8.3 liters
Units ship with 15W-40 API CJ4 low ash oil.	
Engine coolant capacity	4.9 gallons 18.5 liters

1104D-E44TA, GTH-844, GTH-1056

Low idle	1000 rpm
High idle	2500 rpm
Oil capacity (including filter)	10 quarts 9.6 liters
Units ship with 15W-40.	
Engine coolant capacity Type: Extended Life	4.6 gallons 17.4 liters

1204E-E44TA, GTH-1056

Low idle	800 rpm
High idle	2200 rpm
Oil capacity (including filter)	8.8 quarts 8.3 liters
Units ship with 15W-40 API CJ4 low ash oil.	
Engine coolant capacity Type: Extended Life	4.9 gallons 18.5 liters

1204E-E44TA, GTH-1256, GTH-1544

Low idle	800 rpm
High idle	2200 rpm
Oil capacity (including filter)	14.8 quarts 14 liters
Units ship with 15W-40 API CJ4 low ash oil.	
Engine coolant capacity Type: Ethylene Glycol	7.7 gallons 29 liters

Extreme operating temperatures may require the use of alternative engine oils. For oil requirements, refer to the Engine Operator Manual for your engine.

Powertrain Specifications

Dana Transmission Models

Dana Integral Gear Box Shift on Fly

Transmission Type: Hydrostatic with Mechanical Gear, 2 speed

Oil capacity, gear box 1.69 quarts
1.6 liters

Units ship with SAE 85W90 API GL4.

Dana T20000

Transmission Type: 3 speed powershift

Oil capacity, gear box 20 quarts
18.9 liters

Units ship with Chevron RPM SAE 10W.

Extreme operating temperatures may require the use of alternative transmission oils. For oil requirements, refer to the Dana T20000 Maintenance Manual.

Dana VDT12000

Transmission Type: 3 speed powershift

Oil capacity, transmission 14.3 quarts
13.5 liters

Oil capacity, gear box 1.1 quarts
1 liters

Units ship with Chevron Ursa Hydraulic 10W.

Extreme operating temperatures may require the use of alternative transmission oils. For oil requirements, refer to the Dana VDT12000 Service Manual.

ZF Transmission Models

ZF 4 WG-98 TC

Transmission Type: 4 speed powershift

Oil capacity 16.9 quarts
16 liters

Units ship with Chevron Delo 400 LE SAE 15W40.

Extreme operating temperatures may require the use of alternative transmission oils. For oil requirements, refer to the ZF 4 WG-98 TC Maintenance Manual.

Powertrain Specifications

Carraro Axle Models

Carraro 26.27M Drive Axle

Front Axle Lubrication

Front differential	7.4 quarts 7 liters
Axle planetary end (each)	0.8 quarts 0.8 liters

Rear Axle Lubrication

Rear differential	7.9 quarts 7.5 liters
Axle planetary end (each)	0.8 quarts 0.8 liters

Oil viscosity requirements

Differential	Chevron Supreme 80W90 L
Planetary ends	Chevron Supreme 80W90 L

Comer Axle Models

Comer Drive Axle

Front Axle Lubrication

Front differential	5.28 quarts 5 liters
Axle planetary end (each)	1 quart 0.95 liters

Rear Axle Lubrication

Rear differential	5.28 quarts 5 liters
Axle planetary end (each)	1 quart 0.95 liters

Drop Box Lubrication

Drop Box	1.04 quarts 0.98 liters
----------	----------------------------

Oil viscosity requirements

Differential	API GL5 (MIL L-2105)
Planetary ends	API GL5 (MIL L-2105)

Dana Axle Models

Dana 212 Drive Axle

Front Axle Lubrication

Front differential	7.4 quarts 7 liters
Axle planetary end (each)	0.8 quarts 0.8 liters

Rear Axle Lubrication

Rear differential	8 quarts 7.6 liters
Axle planetary end (each)	0.8 quarts 0.8 liters

Oil viscosity requirements

Differential	Chevron Supreme 85W90 (API GL5)
Planetary ends	Chevron Supreme 85W90 (API GL5)

Dana Planetary 213 Drive Axle

Front Axle Lubrication

Front differential	15 quarts 14.2 liters
Axle planetary end (each)	2 quarts 1.9 liters

Rear Axle Lubrication

Rear differential	15 quarts 14.2 liters
Axle planetary end (each)	2 quarts 1.9 liters

Oil viscosity requirements

Differential	Chervron Supreme 80W90 LS
Planetary ends	Chervron Supreme 80W90 LS

Hydraulic Specifications

GTH-636

Primary Function Manifold

System pressure, maximum	3200 psi 221 bar
Fork tilt relief valve pressure, maximum	3500 psi 241 bar
Flow regulator, Sway circuit	2 gpm 7.5 L/min

Secondary Function Manifold

Steer relief valve pressure, maximum	2650 psi 182.7 bar
Parking brake relief valve pressure, maximum	350 psi 24.1 bar
Joystick relief valve pressure, maximum	400 psi 27.5 bar

GTH-844

Primary Function Manifold

System pressure, maximum	3250 psi 224 bar
Fork tilt relief valve pressure, maximum	3500 psi 241 bar
Flow regulator, Sway circuit	2 gpm 7.5 L/min

Secondary Function Manifold

Steer relief valve pressure, maximum	2650 psi 182.7 bar
Parking brake relief valve pressure, maximum	350 psi 24.1 bar
Differential lock relief valve pressure, maximum	400 psi 27.5 bar
Rear lock-up relief valve pressure, maximum	50 psi 3.4 bar

GTH-1056

Primary Function Manifold

System pressure, maximum	3200 psi 221 bar
Boom extend relief valve pressure, maximum	3500 psi 241 bar
Fork tilt relief valve pressure, maximum	3500 psi 241 bar
Flow regulator, Fork tilt circuit	14 gpm 53 L/min
Flow regulator, Sway circuit	2 gpm 7.5 L/min
Flow regulator, Pilot pressure bleed circuit	0.1 gpm 1.4 L/min

Secondary Function Manifold

Steer relief valve pressure, maximum	2500 psi 172 bar
Parking brake relief valve pressure, maximum	400 psi 27.5 bar
Differential lock relief valve pressure, maximum	400 psi 27.5 bar
Rear lock-up relief valve pressure, maximum	50 psi 3.4 bar

Outrigger Manifold

Flow regulator, Outrigger circuit	6 gpm 22.7 L/min
-----------------------------------	---------------------

Hydraulic Specifications

GTH-1256

Function Manifold

System relief valve pressure, maximum	4060 psi 280 bar
Fork tilt relief valve pressure, maximum	4350 psi 300 bar

Auxiliary function manifold - Outriggers /chassis leveling

Steer relief valve pressure, maximum	2610 psi 180 bar
Parking brake relief valve pressure, maximum	406 psi 28 bar
Differential lock relief valve pressure, maximum	406 psi 28 bar
Rear lock-up relief valve pressure, maximum	406 psi 28 bar
Sway relief valve pressure, maximum	3335 psi 230 bar
Auxiliary line relief valve pressure, maximum	3335 psi 230 bar
Transmission gearbox speed shifting relief valve pressure, maximum	406 psi 28 bar

GTH-1544

Function Manifold

System relief valve pressure, maximum	3770 psi 260 bar
Fork tilt relief valve pressure, maximum	4060 psi 280 bar

Secondary Function Valves

Steer relief valve pressure, maximum	2610 psi 180 bar
Parking brake relief valve pressure, maximum	406 psi 28 bar
Differential lock relief valve pressure, maximum	406 psi 28 bar
Rear lock-up relief valve pressure, maximum	406 psi 28 bar
Sway relief valve pressure, maximum	3335 psi 230 bar
Auxiliary line relief valve pressure, maximum	3335 psi 230 bar
Transmission gearbox speed shifting relief valve pressure, maximum	406 psi 28 bar

GTH-5519

Function Manifold

System relief valve pressure, maximum	3915 psi 270 bar
Fork tilt relief valve pressure, maximum	4205 psi 290 bar

Secondary Function Valves

Steer relief valve pressure, maximum	2030 psi 140 bar
Steer anti-shock relief valve pressure, maximum	2900 psi 200 bar
Parking brake relief valve pressure, maximum	360 psi 25 bar
Auxiliary line relief valve pressure, maximum	3915 psi 270 bar

Hydraulic Specifications

Hydraulic Oil Specifications

Hydraulic Fluid Specifications

Genie specifications require hydraulic oils which are designed to give maximum protection to hydraulic systems, have the ability to perform over a wide temperature range, and the viscosity index should exceed 140. They should provide excellent antiwear, oxidation prevention, corrosion inhibition, seal conditioning, and foam and aeration suppression properties.

Cleanliness level, minimum	ISO 15/13
Water content, maximum	250 ppm

Recommended Hydraulic Fluid

Hydraulic oil type	Chevron Rando HD Premium
ISO Grade	32
Viscosity index, maximum	200

Optional Hydraulic Fluids

Mineral based	Shell Tellus S2 V 32
	Shell Tellus S2 V 46
	Shell Tellus S4 VX 32
	Shell Donax TG (Dexron III)
	Chevron 5606A
Biodegradable	Petro Canada Environ MV 46
Fire resistant	UCON Hydrolube HP-5046

Note: Genie specifications require additional equipment and special installation instructions for the approved optional fluids. Consult Genie Product Support before use.

NOTICE Optional fluids may not have the same hydraulic lifespan and may result in component damage.

Note: Extended machine operation can cause the hydraulic fluid temperature to increase beyond its maximum allowable range. If the hydraulic fluid temperature consistently exceeds 200°F / 90°C an optional oil cooler may be required.

NOTICE

Do not top off with incompatible hydraulic fluids. Hydraulic fluids may be incompatible due to the differences in base additive chemistry. When incompatible fluids are mixed, insoluble materials may form and deposit in the hydraulic system, plugging hydraulic lines, filters, control valves and may result in component damage.

Note: Do not operate the machine when the ambient air temperature is consistently above 120°F / 49°C.

Hydraulic Fluid Temperature Range

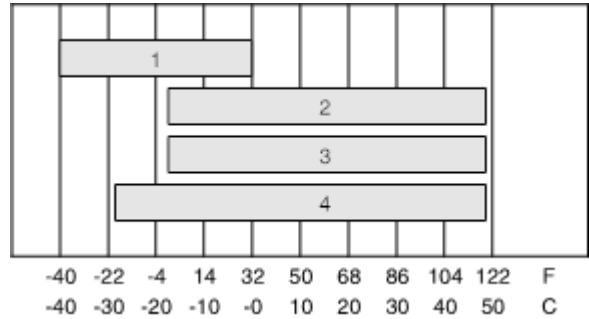

Ambient air temperature

- 1 Chevron hydraulic oil 5606A
- 2 Petro-Canada Environ MV 46
- 3 UCON Hydrolube HP-5046D
- 4 Chevron Rando HD premium oil MV

Hydraulic Specifications

Chevron Rando HD Premium Oil MV Fluid Properties

ISO Grade	32
Viscosity index, maximum	200
Kinematic Viscosity, maximum cSt @ 200°F / 100°C	7.5
cSt @ 104°F / 40°C	33.5
Brookfield Viscosity, maximum cP @ -4°F / -20°C	1040
cP @ -22°F / -30°C	3310
Flash point	375°F / 190°C
Pour point	-58°F / -50°C
Maximum continuous operating temperature	171°F / 77°C

Note: A hydraulic oil heating system is recommended when the ambient temperature is consistently below 0°F / -18°C.

Note: Do not operate the machine when the ambient temperature is below -20°F / -29°C with Rando HD Premium MV.

Chevron 5606A Hydraulic Oil Fluid Properties

ISO Grade	15
Viscosity index, maximum	300
Kinematic Viscosity, maximum cSt @ 200°F / 100°C	5.5
cSt @ 104°F / 40°C	15.0
cSt @ -40°F / -40°C	510
Flash point	180°F / 82°C
Pour point	-81°F / -63°C
Maximum continuous operating temperature	124°F / 51°C

Note: Use of Chevron 5606A hydraulic fluid, or equivalent, is required when ambient temperatures are consistently below 0°F / -17°C unless an oil heating system is used.

NOTICE

Continued use of Chevron 5606A hydraulic fluid, or equivalent, when ambient temperatures are consistently above 32°F / 0°C may result in component damage

Hydraulic Specifications

Petro-Canada Environ MV 46 Fluid Properties

ISO Grade	46
Viscosity index, maximum	154
Kinematic Viscosity, maximum	
cSt @ 200°F / 100°C	8.0
cSt @ 104°F / 40°C	44.4
Flash point	482°F / 250°C
Pour point	-49°F / -45°C
Maximum continuous operating temperature	180°F / 82°C

Shell Tellus S4 VX Fluid Properties

ISO Grade	32
Viscosity index, maximum	300
Kinematic Viscosity, maximum	
cSt @ 200°F / 100°C	9
cSt @ 104°F / 40°C	33.8
Brookfield Viscosity, maximum	
cSt @ -4°F / -20°C	481
cSt @ -13°F / -25°C	702.4
cSt @ -40°F / -40°C	2624
Flash point	>100
Pour point	-76°F / -60°C
Maximum continuous operating temperature	103°F / 75°C

UCON Hydrolube HP-5046 Fluid Properties

ISO Grade	46
Viscosity index, maximum	192
Kinematic Viscosity, maximum	
cSt @ 149°F / 65°C	22
cSt @ 104°F / 40°C	46
cSt @ 0°F / -18°C	1300
Flash point	None
Pour point	-81°F / -63°C
Maximum continuous operating temperature	189°F / 87°C

Hydraulic Specifications

Hydraulic Hose and Fitting Torque Specifications

Your machine is equipped with Parker Seal-Lok™ ORFS or 37° JIC fittings and hose ends. Genie specifications require that fittings and hose ends be torqued to specification when they are removed and installed or when new hoses or fittings are installed.

Seal-Lok™ Fittings (hose end - ORFS)	
SAE Dash Size	Torque
-4	18 ft-lbs / 25 Nm
-6	30 ft-lbs / 41 Nm
-8	40 ft-lbs / 55 Nm
-10	60 ft-lbs / 81 Nm
-12	85 ft-lbs / 115 Nm
-16	110 ft-lbs / 150 Nm
-20	150 ft-lbs / 205 Nm
-24	230 ft-lbs / 315 Nm

JIC 37° Fittings (swivel nut or hose connection)		
SAE Dash Size	Thread Size	Flats
-4	7/16-20	2
-6	9/16-18	1 1/2
-8	3/4-16	1 1/2
-10	7/8-14	1 1/2
-12	1 1/16-12	1 1/4
-16	1 5/16-12	1
-20	1 5/8-12	1
-24	1 7/8-12	1

SAE O-ring Boss Port

(tube fitting - installed into Aluminum)
(all types)

SAE Dash Size	Torque
-4	14 ft-lbs / 19 Nm
-6	23 ft-lbs / 31,2 Nm
-8	36 ft-lbs / 49 Nm
-10	62 ft-lbs / 84 Nm
-12	84 ft-lbs / 114 Nm
-16	125 ft-lbs / 169,5 Nm
-20	151 ft-lbs / 204,7 Nm
-24	184 ft-lbs / 249,5 Nm

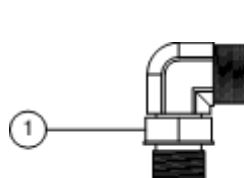

Adjustable Fitting



Non-adjustable fitting

1 jam nut

SAE O-ring Boss Port

(tube fitting - installed into Steel)

SAE Dash Size	Torque
-4 ORFS / 37° (Adj)	15 ft-lbs / 20,3 Nm
ORFS (Non-adj)	26 ft-lbs / 35,3 Nm
37° (Non-adj)	22 ft-lbs / 30 Nm
-6 ORFS (Adj / Non-adj)	35 ft-lbs / 47,5 Nm
37° (Adj / Non-adj)	29 ft-lbs / 39,3 Nm
-8 ORFS (Adj / Non-adj)	60 ft-lbs / 81,3 Nm
37° (Adj / Non-adj)	52 ft-lbs / 70,5 Nm
-10 ORFS (Adj / Non-adj)	100 ft-lbs / 135,6 Nm
37° (Adj / Non-adj)	85 ft-lbs / 115,3 Nm
-12 (All types)	135 ft-lbs / 183 Nm
-16 (All types)	200 ft-lbs / 271,2 Nm
-20 (All types)	250 ft-lbs / 339 Nm
-24 (All types)	305 ft-lbs / 413,5 Nm

Hydraulic Specifications

Torque Procedure

Seal-Lok™ fittings

- 1 Replace the O-ring. The O-ring must be replaced anytime the seal has been broken. The O-ring cannot be re-used if the fitting or hose end has been tightened beyond finger tight.

Note: The O-ring in Parker Seal Lok™ fittings and hose end are custom-size O-rings. They are not standard size O-rings. They are available in the O-ring field service kit (Genie part number 49612).

- 2 Lubricate the O-ring before installation.
- 3 Be sure the O-ring face seal is seated and retained properly.
- 4 Position the tube and nut squarely on the face seal end of the fitting, and tighten the nut finger tight.
- 5 Tighten the nut or fitting to the appropriate torque. Refer to the appropriate torque chart in this section.
- 6 Operate all machine functions and inspect the hose, fittings and related components to confirm there are no leaks.

JIC 37° fittings

- 1 Align the tube flare (hex nut) against the nose of the fitting body (body hex fitting) and tighten the hex nut to the body hex fitting to hand tight, approximately 30 in-lbs / 3.4 Nm.
- 2 Using a permanent ink marker, make a reference mark on one the flats of the hex nut and continue the mark onto the body of the hex fitting. Refer to Illustration 1.

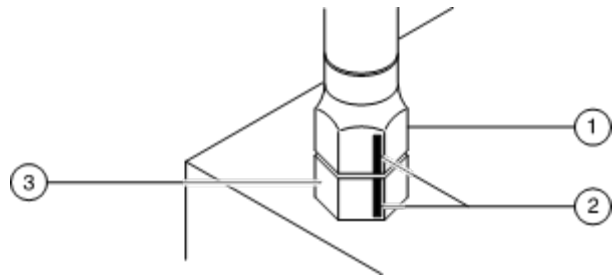

Illustration 1

- 1 hex nut
- 2 reference mark
- 3 body hex fitting

Hydraulic Specifications

- 3 Working clockwise on the body hex fitting, make a second mark with a permanent ink marker to indicate the proper tightening position. Refer to Illustration 2.

Note: Use the JIC 37° Fitting table in this section to determine the correct number of flats, for the proper tightening position.

Note: The marks indicate the correct tightening positions have been determined. Use the second mark on the body hex fitting to properly tighten the joint after it has been loosened.

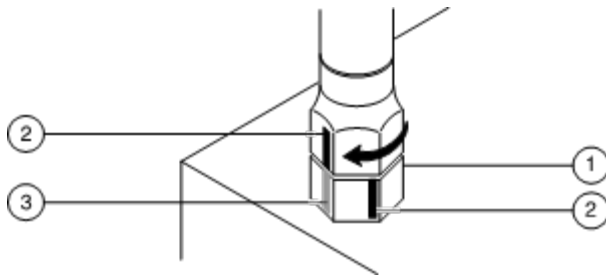

Illustration 2

- 1 body hex fitting
- 2 reference mark
- 3 second mark

- 4 Tighten the hex nut until the mark on the hex nut is aligned with the second mark on the body hex fitting.
- 5 Operate all machine functions and inspect the hose, fittings and related components to confirm there are no leaks.

Maintenance Procedures



Observe and Obey:

- ☑ Maintenance inspections shall be completed by a person trained and qualified on the maintenance of this machine.
- ☑ Scheduled maintenance inspections shall be completed as specified on the *Maintenance Inspection Reports*. The frequency and extent of periodic examinations and tests may also depend on national regulations.

▲ WARNING

Failure to perform each procedure as presented and scheduled may cause death, serious injury or substantial damage.

- ☑ Immediately tag and remove from service a damaged or malfunctioning machine.
- ☑ Repair any machine damage or malfunction before operating the machine.
- ☑ Use only Genie approved replacement parts.
- ☑ Machines that have been out of service for a period longer than 3 months must complete the quarterly inspection.

Machine Configuration:

- ☑ Unless otherwise specified, perform each procedure with the machine in the following configuration:
 - Machine parked on a firm, level surface
 - Boom in the stowed position
 - Key switch in the off position with the key removed
 - Wheels chocked

Maintenance Procedures

About This Section

This section contains detailed procedures for each scheduled maintenance inspection.

Each procedure includes a description, safety warnings and step-by-step instructions.

Symbols Legend



Safety alert symbol—used to alert personnel to potential personal injury hazards. Obey all safety messages that follow this symbol to avoid possible injury or death.



Indicates a imminently hazardous situation which, if not avoided, will result in death or serious injury.



Indicates a potentially hazardous situation which, if not avoided, could result in death or serious injury.



Indicates a potentially hazardous situation which, if not avoided, may cause minor or moderate injury.



Indicates a potentially hazardous situation which, if not avoided, may result in property damage.

- ⊙ Indicates that a specific result is expected after performing a series of steps.
- ⊗ Indicates that an incorrect result has occurred after performing a series of steps.

Maintenance Symbols Legend

Note: The following symbols have been used in this manual to help communicate the intent of the instructions. When one or more of the symbols appear at the beginning of a maintenance procedure, it conveys the meaning below.



Indicates that tools will be required to perform this procedure.



Indicates that new parts will be required to perform this procedure.



Indicates that dealer service will be required to perform this procedure.



Indicates that a cold motor/pump or engine will be required to perform this procedure.



Indicates that a warm engine will be required to perform this procedure.

Maintenance Procedures

Maintenance Schedule

The maintenance procedures have been divided into subsections that include: Commissioning, Quarterly, Annually and Programmed maintenance intervals. The maintenance inspection report has been divided into general areas of the machine that include: Drive Chassis, Booms and Fork, Functions and Controls and Powertrain.

Failure to perform these procedures may result in poor performance, component damage and unsafe operating conditions. They are essential to safe operation, machine performance and service life.

Commissioning: A series of required one time maintenance procedures to be performed at 50 and 150 hour intervals.

Quarterly and Annually: A series of maintenance procedures to be performed quarterly or annually.

Programmed: A series of maintenance procedures to be performed during a Pre-Delivery Preparation or based on machine operating hours.







Maintenance Inspection Report

The maintenance inspection report contains checklists for each type of scheduled inspection.







Make copies of the *Maintenance Inspection Report* to use for each inspection. Maintain completed forms for a minimum of 4 years or in compliance with your employer, jobsite and governmental regulations and requirements.

Instruction Examples









Commissioning Example:

Commissioning		 50	 150
 Engine - all models	 PO-1		





Quarterly and Annually Example:

 Drive Chassis	 Intervals	Q	A
 Inspect the tires, wheels and Lug Nut Torque	 Q-4		 \emptyset

Programmed Example (under 1000 HRS):







Programmed Maintenance - Under 1000 HRS		Status	Enter Hours
 Check Track Tension/Fastener Torque	 P0-1		 50
 Engines - Deutz Under 1000 HRS	 P0-2		

Programmed Example:

Programmed Maintenance	 Hours are in thousands					
All models	1	2	3	4	6	12
 Engine - all models, 1000 hrs	 P1-1		\emptyset	\emptyset	\emptyset	\emptyset

Instructions Legend

Use the following detailed descriptions to identify the intended use of the maintenance inspection reports.

-  Specific Interval: blank box is the interval to be completed and the \emptyset marks the interval as not required.
-  The description of the procedure or checklist to be completed.
-  The procedure number or checklist to be completed.
-  Check box to indicate status of inspection.
-  Specific interval is not required for this procedure.
-  General area of the machine to complete the procedure.
-  If this box has a designated time interval: this is the specific time interval to complete the procedure or checklist.

If this box is empty: the maintenance checklist will include multiple time intervals, use this box to write in the specific interval for the inspection completed.

Pre-Delivery Preparation Report

Fundamentals

It is the responsibility of the owner or dealer to perform the Pre-delivery Preparation.

The Pre-delivery Preparation is performed prior to each delivery. The inspection is designed to discover if anything is apparently wrong with a machine before it is put into service.

A damaged or modified machine must never be used. If damage or any variation from factory delivered condition is discovered, the machine must be tagged and removed from service.

Repairs to the machine may only be made by a qualified service technician, according to the manufacturer's specifications.

Scheduled maintenance inspections shall be performed by qualified service technicians, according to the manufacturer's specifications and the requirements listed in the responsibilities manual.

Instructions

Use the operator's manual on your machine.

The Pre-delivery Preparation consists of completing the Pre-operation Inspection, the Maintenance items and the Function Tests.

Use this form to record the results. Place a check in the appropriate box after each part is completed. Follow the instructions in the operator's manual.

If any inspection receives an N, remove the machine from service, repair and re-inspect it. After repair, place a check in the R box.

Legend

- Y = yes, acceptable
- N = no, remove from service
- R = repaired

Comments

Pre-delivery Preparation	Y	N	R
Pre-operation inspection completed			
Maintenance items completed			
Function tests completed			



Terex South Dakota, Inc USA
 500 Oak Wood Road
 PO Box 1150
 Watertown, SD 57201-6150
 (605) 882-4000

Genie UK
 The Maltings, Wharf Road
 Grantham, Lincolnshire
 NG31-6BH England
 (44) 1476-584333

Model

Serial number

Date

Machine owner

Inspected by (print)

Inspector signature

Inspector title

Inspector company

Model		Hour meter	Date
Serial number		Inspector company	Machine owner
Inspected by (print)		Inspector signature	
Scheduled Maintenance: Inspection Type Q = quarterly or frequent inspections A = annual inspections	Legend Y = yes, acceptable N = no, remove from service R = repaired ∅ = not applicable	Make copies of this report to use for each inspection. Select the appropriate procedures for the type of inspection(s) to perform.	Programmed Maintenance: Programmed maintenance will be completed based on machine hours. This program includes the onetime or commissioning procedures for new products. The onetime procedures will be completed at 50 or 150 hours.
If any inspection receives an "N," tag and remove the machine from service, repair and re-inspect it. After repair, place a "R" in the box.			

Drive Chassis	Intervals	Q	A
Inspect the Tires, Wheels and Lug Nut Torque	Q-6		
Mechanicals and Hydraulics	Intervals	Q	A
Inspect the Fuel and Hydraulic Tank Cap Venting Systems	Q-8		
Visual Inspection of the Hydraulic Oil	Q-9		
Replace Hydraulic Tank Return Filter Element	A-5	∅	
Replace the Cab Air Intake Filter (if equipped)	A-6	∅	
Electrical	Intervals	Q	A
Battery Inspection	Q-2		
Inspect the Electrical Wiring	Q-3		
Powertrain	Intervals	Q	A
Check the Exhaust System	Q-5		
Inspect the Engine Air Filter	Q-10		
Lubricate the Driveshaft	Q-11		
Boom(s) and Fork	Intervals	Q	A
Check the Boom Wear Pads	Q-4		
Inspect the Fork Level and Aux. Hydraulic Hoses	Q-7		
Inspect and Lubricate the Sequencing Chains - GTH-636, 1256, 1544, 844, 1056	Q-12		
Inspect the Forks	A-1	∅	
Adjust the Boom Chains - GTH-636, GTH-844	A-2	∅	
Adjust the Boom Chains - GTH-1056	A-3	∅	
Adjust the Boom Chains - GTH-1256, GTH-1544	A-4	∅	
Functions and Controls	Intervals	Q	A
Check for Open Bulletins and Owner Registration	Q-1		

Commissioning	50	150
Perform 50 Hour Service	C-1	∅
Engine Maintenance - 50 HRS	C-2	∅
Perform 150 Hour Service	C-3	∅

Programmed Maintenance - Under 1000 HRS	Status	Enter Hours
Lubricate the Boom	P0-1	8
Deutz Engine Maintenance – Under 1000 HRS	P0-2	
Perkins Engine Maintenance – Under 1000 HRS	P0-3	
John Deere Engine Maintenance – Under 1000 HRS	P0-4	
Axle Maintenance – Under 1000 HRS	P0-5	
Transmission Maintenance – Under 1000 HRS	P0-6	

Programmed Maintenance	Hours are in thousands					
All models	Perform every:					
	1	2	3	4	6	12
Engines - all models, 1000 HRS	P1-1	∅	∅	∅	∅	∅
Transmissions - all models, 1000 HRS	P1-2	∅	∅	∅	∅	∅
Axles - all models, 1000 HRS	P1-3	∅	∅	∅	∅	∅
Engines - all models, 2000 HRS	P2-1	∅	∅	∅	∅	∅
Test or Replace the Hydraulic Oil	P2-2	∅	∅	∅	∅	∅
Engines - all models, 3000 HRS	P3-1	∅	∅	∅	∅	∅
Engines - all models, 4000 HRS	P4-1	∅	∅	∅	∅	∅
Engines - all models, 6000 HRS	P6-1	∅	∅	∅	∅	∅
Engines - all models, 12000 HRS	P12-1	∅	∅	∅	∅	∅

Commissioning Procedures

C-1 Perform 50 Hour Service



The 50 hour maintenance procedure is a one time sequence of procedures to be performed after the first 50 hours of usage. After this interval, refer to the maintenance inspection report for continued scheduled maintenance.

- 1 Perform the following maintenance procedures:

All Models:

- Q-6 Inspect the Tires, Wheels and Lug Nut Torque
- A-5 Replace the Hydraulic Filters

C-2 Perform Engine Maintenance - 50 Hours



The 50 hour maintenance procedure is a one time sequence of procedures to be performed after the first 50 hours of usage. After this interval, refer to the maintenance inspection report for continued scheduled maintenance.

All Models

- Check Belt Tension
- Check The Engine Mounts
- Check Hose Clamps

John Deere Models

- Engine oil - replace
- Engine filter - replace

Required maintenance procedures and additional engine information are available in the manufacturer's manuals. Refer to Specifications, *Engine Operator and Maintenance Manuals*.

Commissioning Procedures

C-3

Perform 150 Hour Service



The 150 hour maintenance procedure is a one time sequence of procedures to be performed after the first 150 hours of usage. After this interval, refer to the maintenance tables for continued scheduled maintenance.

- 1 Perform the following maintenance procedures:

Q-9 Visual Inspection of the Hydraulic Oil

Quarterly Maintenance Procedures

Q-1 Check for Open Bulletins and Owner Registration



Genie specifications require that this procedure be performed quarterly.

Completing required bulletins is essential to safe machine operation. An important way to ensure your machine has no open bulletins is to frequently check the serial number of your Genie machine against our bulletin database. Using the links below you can view any open bulletins for your machine(s) that require mandatory and immediate work to be completed.

Note: If you are unable to access this information on our websites, please contact your local Genie representative using the contact information provided on the back cover of this manual.

- 1 Locate the serial number plate or label on your machine and document your Genie machine serial number (exactly as its displayed on the serial plate or label).
- 2 Confirm that Genie has the current machine owner information on file by contacting our warranty department at 1-800-536-1800 or use the link included in this procedure to download and complete a New Owner Registration Form.
- 3 Using the link provided, check for current bulletins for your machine(s).

Machines purchased in Australia:

Go to [Australia Bulletins](http://genielift.com.au/contact)
(<http://genielift.com.au/contact>)

- 1 Contact any one of the Genie Service centers around Australia to arrange for factory trained technicians to attend to your equipment needs.

Machines purchased in ASIA, North America and Latin America:

Go to [ASIA, North America and Latin America Bulletins](https://www.gogenielift.com/) (<https://www.gogenielift.com/>)

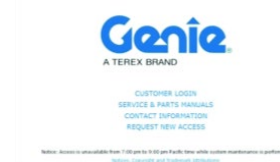

- 1 Select "Customer Login" to login or select "Request New Access" to create a new account.
- 2 At the homepage, select "Unit Configuration" and enter your machine serial number.
- 3 Press the "Lookup" button to view your machine configuration and to check for open bulletins.
- 4 Complete all required bulletins shown for your specific machine serial number.

Machines purchased in Europe, Middle East, Africa, and Russia:

Go to [EMEAR Bulletins](http://www.genielift.co.uk/en/sales-and-support/bulletin-campaigns/index.htm)
(<http://www.genielift.co.uk/en/sales-and-support/bulletin-campaigns/index.htm>)



- 1 Enter your machine serial number and press search to check for open bulletins.
- 2 Complete all required bulletins shown for your specific machine serial number.

Quarterly Maintenance Procedures

Q-2 Battery Inspection



Genie specifications require that this procedure be performed quarterly.

Proper battery condition is essential to good engine and machine performance and operational safety. Improper fluid levels or damaged cables and connections can result in engine and component damage and hazardous conditions.

▲ WARNING

Electrocution/burn hazard. Contact with electrically charged circuits could result in death or serious injury. Remove all rings, watches and other jewelry.

▲ WARNING

Bodily injury hazard. Batteries contain acid. Avoid spilling or contacting battery acid. Neutralize battery acid spills with baking soda and water.

Note: Fully charge the batteries and allow the batteries to rest 24 hours before performing this procedure to allow the battery cells to equalize.

- 1 Verify that the battery cable connections are free of corrosion.

Note: Adding terminal protectors and a corrosion preventative sealant will help eliminate corrosion on the battery terminals and cables.

- 2 Verify that the battery retainers and cable connections are tight.
- 3 Verify that the battery separator wire connections are tight (if equipped).

Models without maintenance-free or sealed batteries:

- 4 Put on protective clothing and eye wear.
- 5 Remove the battery vent caps and check the specific gravity of each battery cell with a hydrometer. Note the results.
- 6 Check the ambient air temperature and adjust the specific gravity reading for each cell as follows:
 - Add 0.004 to the reading of each cell for every 10° F / 5,5° C above 80° F / 26,7° C.
 - Subtract 0.004 from the reading of each cell for every 10° F / 5,5° C below 80° F / 26,7° C.
- ⊙ Result: All battery cells display an adjusted specific gravity of 1.277 or higher. The battery is fully charged. Proceed to step 10.
- ⊗ Result: One or more battery cells display a specific gravity of 1.276 or below. Proceed to step 7.
- 7 Perform an equalizing charge OR fully charge the battery(s) and allow the battery(s) to rest at least 6 hours.
- 8 Remove the battery vent caps and check the specific gravity of each battery cell with a hydrometer. Note the results.

Quarterly Maintenance Procedures

- 9 Check the ambient air temperature and adjust the specific gravity reading for each cell as follows:
- Add 0.004 to the reading of each cell for every 10° F / 5,5° C above 80° F / 26,7° C.
 - Subtract 0.004 from the reading of each cell for every 10° F / 5,5° C below 80° F / 26,7° C.
- ⊙ Result: All battery cells display a specific gravity of 1.277 or greater. The battery is fully charged. Proceed to step 10.
- ⊗ Result: One or more battery cells display a specific gravity from 1.218 to 1.269. The battery is still usable, but at a lower performance. The battery will need to be recharged more often. Proceed to step 10.
- ⊗ Result: One or more battery cells display a specific gravity from 1.217 to 1.173. The battery is approaching the end of its life. Proceed to step 10.
- ⊗ Result: The difference in specific gravity readings between cells is greater than 0.1 OR the specific gravity of one or more cells is less than 1.177. Replace the battery.
- 10 Check the battery acid level. If needed, replenish with distilled water to 1/8 inch / 3 mm below the bottom of the battery fill tube. Do not overfill.
- 11 Install the vent caps and neutralize any electrolyte that may have spilled.

Q-3

Inspect the Electrical Wiring



Genie specifications require that this procedure be performed quarterly.

Maintaining electrical wiring in good condition is essential to safe operation and good machine performance. Failure to find and replace burnt, chafed, corroded or pinched wires could result in unsafe operating conditions and may cause component damage.

⚠ WARNING

Electrocution/burn hazard. Contact with electrically charged circuits could result in death or serious injury. Remove all rings, watches and other jewelry.

- 1 Inspect the following areas for burnt, chafed, corroded and loose wires:
 - Inside of the operator's compartment
 - Underside of the chassis
 - Inside engine compartment
- 2 Inspect for a lite, even coating of dielectric grease in the following locations:
 - All harness connectors

Note: Do not apply excessive amounts of dielectric grease to harness connectors, pins or sockets.

Note: Do not apply dielectric grease to a engine ECU/ECM or engine harness connectors.

- 3 Start the engine and raise the boom so there is enough room to access and remove all the covers attached to the chassis.
- 4 Attach a lifting strap from an overhead crane to the boom. Support the boom. Do not apply any lifting pressure.

Quarterly Maintenance Procedures

- 5 Remove all engine covers, hydraulic tank covers and chassis covers.

▲ DANGER

Crushing hazard. Death or serious injury could result if the boom should unexpectedly fall while working underneath the boom. Do not stand or work beneath a boom that is not properly supported.

- 6 Inspect the following areas for burnt, chafed, corroded, pinched and loose wires:
- Engine
 - Transmission
 - Manifolds
 - Chassis
- 7 Inspect for a lite, even coating of dielectric grease in all connections between the transmission and the operator's compartment.

Note: Do not apply excessive amounts of dielectric grease to harness connectors, pins or sockets.

Note: Do not apply dielectric grease to a engine ECU/ECM or engine harness connectors.

- 8 Install all covers removed in step 5.
- 9 Remove the lifting strap from the overhead crane.
- 10 Start the engine and lower the boom to the stowed position. Turn the machine off.

Q-4

Check the Boom Wear Pads



Genie specifications require that this procedure be performed quarterly.

GTH-636, GTH-844, GTH-1056

- 1 Extend the boom until the wear pads are accessible.

Note: It may be necessary to remove the wear pad retainer plates to expose the wear pads.

- 2 Inspect the end of each upper wear pad.

- Result: The wear pad grooves are visible on the end of the wear pad.
- ☒ Result: The grooves on the end of the wear pad are no longer visible. Replace both wear pads. Refer to the appropriate Service and Repair Manual for repair procedure, *How to Replace the Boom Wear Pads*.

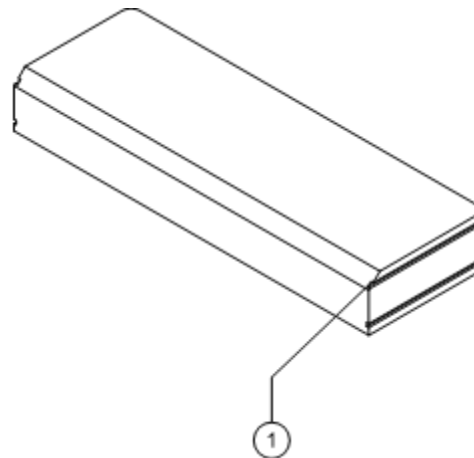

1 wear pad groove

Quarterly Maintenance Procedures

- 3 Repeat the procedure for the lower wear pads.
- 4 Measure each side wear pad.
- ⦿ Result: The measurement is within specification.
- ⊗ Result: The measurement is less than specification. Replace all side wear pads. Refer to the appropriate Service and Repair Manual for repair procedure, *How to Replace the Boom Wear Pads*.

Boom Wear Pad Specifications

Side wear pad thickness, minimum	3/8 inch 9.5 mm
----------------------------------	--------------------

GTH-1256, GTH-1544 and GTH-5519

- 1 Extend the boom until the wear pads are accessible.
- 2 Inspect each pad and ensure that the pad thickness is more than 0.04 inches / 1 mm (see figure).
- ⦿ Result: If thickness is above 0.04 inches / 1 mm, the pad can be re-used.

Result: if thickness is less than 0.04 inches / 1 mm, replace the worn pad. Refer to the appropriate Service and Repair Manual for repair procedure, *How to Replace the Boom Wear Pads*.

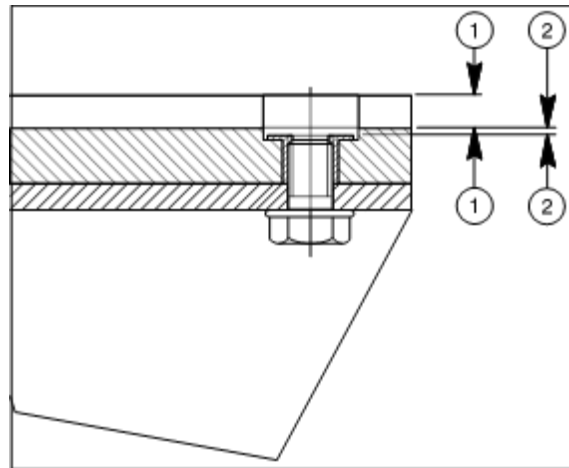

- 1 Maximum wearing thickness
- 2 Minimum wearing thickness

Boom Wear Pad Screws Tightening Specifications

Screws M10	22 ft-lbs 30 Nm
------------	--------------------

Quarterly Maintenance Procedures

Q-5 Check the Exhaust System

Genie specifications require that this procedure be performed quarterly.

Maintaining the exhaust system is essential to good engine performance and service life. Operating the engine with a damaged or leaking exhaust system can cause component damage and unsafe operating conditions.

▲ WARNING Bodily injury hazard. Do not inspect while the engine is running. Remove the key to secure from operation.

▲ CAUTION Burn hazard. Beware of hot engine components. Contact with hot engine components may result in severe burns.

- 1 Be sure that all nuts and bolts are tight.
- 2 Inspect all welds for cracks.
- 3 Inspect for exhaust leaks; i.e., carbon buildup around seams and joints.

Q-6 Inspect the Tires, Wheels and Lug Nut Torque



Genie specifications require that this procedure be performed quarterly.

Maintaining the tires and wheels, including proper wheel fastener torque, is essential to safe operation and good performance. Tire and/or wheel failure could result in a machine tip-over. Component damage may also result if problems are not discovered and repaired in a timely fashion.

▲ WARNING Bodily injury hazard. An over-inflated tire can explode and could cause death or serious injury.

▲ WARNING Tip-over hazard. Do not use temporary flat tire repair products.

Note: The tires on some machines are foam-filled or solid rubber and do not need air added to them.

Note: Refer to Specifications. *Torque Specifications, Tires and Wheels.*

- 1 Check all tire treads and sidewalls for cuts, cracks, punctures and unusual wear.
- 2 Check each wheel for damage, bends and cracked welds.
- 3 Check each lug nut for proper torque.
- 4 Check the pressure in each air-filled tire.

Quarterly Maintenance Procedures

Q-7 Inspect the Fork Level and Auxiliary Hydraulic Hoses Tension



Genie specifications require that this procedure be performed quarterly.

- 1 Fully retract the boom.
 - 2 Fully lower the tips of the lifting forks.
 - 3 Remove the cover from the fork end of the boom.
 - 4 Inspect the fork level and/or auxiliary hydraulic hoses for proper tension. Each hose should have the same amount of droop and should not rest on the boom tube.
- ⊗ Result: The hose/s rest on the boom tube or have an unequal amount of droop. Refer to the appropriate Service and Repair Manual for repair procedure, *How to Adjust the Fork Level and Auxiliary Hydraulic Hose Tension*.

Q-8 Inspect the Fuel and Hydraulic Tank Cap Venting Systems



Genie specifications require that this procedure be performed quarterly.

Perform this procedure more often if dusty conditions exist.

Free-breathing fuel and hydraulic tank caps are essential for good machine performance and service life. A dirty or clogged tank cap may cause the machine to perform poorly and continued use may cause component damage. Extremely dirty conditions may require that the caps be inspected more often.



Explosion and fire hazard. Engine fuels are combustible. Perform this procedure in an open, well-ventilated area away from heaters, sparks, flames and lighted tobacco. Always have an approved fire extinguisher within easy reach.

Note: Perform this procedure with the engine off.

GTH-636 and GTH-844

- 1 Identify the vent tube breather from the fuel tank under the chassis center cover.
- 2 Check for proper venting.
 - ⦿ Result: Air passes through the vent tube. Proceed to **Hydraulic Tank Breather Cap**.
 - ⊗ Result: If air does not pass through the vent tube, clean or replace the tube. Proceed to step 3.

Note: When checking for positive tank cap venting, air should pass freely through the tube.

- 3 Using a mild solvent, carefully wash the tube venting system. Dry using low pressure compressed air. Repeat this procedure beginning with step 2.

Quarterly Maintenance Procedures

GTH-1056, GTH-1256, GTH-1544 and GTH-5519:

- 1 Remove the fuel filler cap from the tank.
- 2 Check for proper venting.
- ⦿ Result: Air passes through the fuel tank cap. Proceed to step 4.
- ⊗ Result: If air does not pass through the cap, clean or replace the cap. Proceed to step 3.

Note: When checking for positive tank cap venting, air should pass freely through the cap.

- 3 Using a mild solvent, carefully wash the cap venting system. Dry using low pressure compressed air. Repeat this procedure beginning with step 2.
- 4 Install the fuel tank cap onto the fuel tank.

Hydraulic Tank Breather Cap - All Models

- 1 Remove the breather cap from the hydraulic tank.
- 2 Check for proper venting. The cap is pressurized to 3 psi.
- ⦿ Result: Air passes through the breather cap. Proceed to step 4.
- ⊗ Result: If air does not pass through the cap, clean or replace the cap. Proceed to step 3.

Note: When checking for positive tank cap venting, air should pass freely through the cap.

- 3 Using a mild solvent, carefully wash the cap venting system. Dry using low pressure compressed air. Repeat this procedure beginning with step 2.
- 4 Install the breather cap onto the hydraulic tank.

Q-9

Visual Inspection of the Hydraulic Oil



Genie specifications require that this procedure be performed quarterly.

Replacement or testing of the hydraulic oil is essential for good machine performance and service life. Dirty oil and a clogged suction strainer may cause the machine to perform poorly and continued use may cause component damage. Extremely dirty conditions may require oil changes to be performed more often. For hydraulic oil specifications, Refer to Specifications, *Hydraulic Specifications*.

Note: Before replacing the hydraulic oil, the oil may be tested by an oil distributor for specific levels of contamination to verify that changing the oil is necessary. Replace the oil when it fails the test. Refer to Maintenance Procedure, *Test or Replace the Hydraulic Oil*.

Quarterly Maintenance Procedures

- 1 Collect a sample of hydraulic oil and place in a clear container. Visually inspect the hydraulic oil for the following:
 - Color: oil should be a clear, light-honey colored
 - Appearance, oil should be clear and not cloudy or visibly distorts the view through the sight glass or container
 - Contains no particles, foreign objects, or other contamination
 - The hydraulic oil can be inspected by smell (can smell “hot” but not “burnt”) or rubbing between fingers (should feel viscous and free of any rough feel due to particles)
- ⦿ If the hydraulic oil passes all of the above inspections, continue the scheduled maintenance intervals.
- ⊗ If the hydraulic oil fails any of the above inspections, the hydraulic oil must be tested by an oil distributor or replaced.

Note: If the hydraulic oil was not replaced at or before the 2000 hour maintenance interval, the oil must be tested every quarter by an oil distributor until the oil fails the test and is replaced. After the oil has been replaced, continue the scheduled quarterly maintenance inspection.

Note: When replacing the hydraulic oil, it is recommended that all hydraulic filters be replaced at the same time.

Q-10

Inspect the Engine Air Filter



Genie specifications require that this procedure be performed quarterly.

Perform this procedure more often if dusty conditions exist.

Maintaining the engine air filter in good condition is essential to good engine performance and service life. Failure to perform this procedure can lead to poor engine performance and component damage.

Note: Perform this procedure with the engine off.

- 1 Release the latches on the cover of the air cleaner assembly. Remove the cover.
- 2 Gently twist and pull out the external or primary filter element.
- 3 Remove the inner or secondary filter element.
- 4 Clean the inside of the canister and the gasket with a damp cloth.
- 5 Inspect the primary and secondary air filter elements. If needed, blow from the inside out using low pressure dry compressed air, or carefully tap out dust.
- 6 Install the secondary filter element first, then install the primary filter element.
- 7 Install the front cover onto the air cleaner assembly and secure the latches.

Quarterly Maintenance Procedures

Q-11 Lubricate the Driveshaft



Genie specifications require that this procedure be performed quarterly.

Greasing the specified locations is essential for good machine performance and service life. Operating the machine with little or no grease may cause the machine to perform poorly and continued use may cause component damage.

- 1 Using a grease gun, thoroughly grease each driveshaft, at both ends of the driveshaft.

Grease Specifications

Chevron Ultra-duty grease, EP NLGI 2 (lithium based) or equivalent

Q-12 Inspect and Lubricate the Sequencing Chains - GTH-636, GTH-1256, GTH-1544, GTH-844 and GTH-1056



Genie specifications require that this procedure be performed quarterly.

In extremely dusty or hostile environments, it may be necessary to lubricate the chains more often.

Maintaining the sequencing chains in good condition is essential to safe operation and good machine performance. Failure to detect damage to the chains could result in a hazardous operating condition.

Environments in which Genie Telehandlers operate can vary widely from outdoor moisture and temperature extremes, to mildly corrosive or highly corrosive industrial atmospheres, in addition to abrasive exposures such as sand and grit.

In addition, dynamic shock loading can impose abnormal loads above the endurance limit of the chains. Examples of dynamic shock loading are:

- High velocity movement of load, followed by sudden abrupt stops.
- Carrying loads in suspension over irregular surfaces and rough terrain.
- Attempting to "inch" loads which are beyond the rated capacity of the vehicle.

The load cycles and environmental conditions make it impossible to predict chain life. It is therefore necessary to conduct regular inspections.

Quarterly Maintenance Procedures

- 1 Park the machine on a firm level surface, level the boom and engage the parking brake.
- 2 Fully extend the boom.
- 3 Inspect the chains for the following conditions:

GTH-636, GTH-844 and GTH-1056 models

- Elongation
- BL666 chain - Measure 16 pitches of the extend chain for machines using BL666 chain.

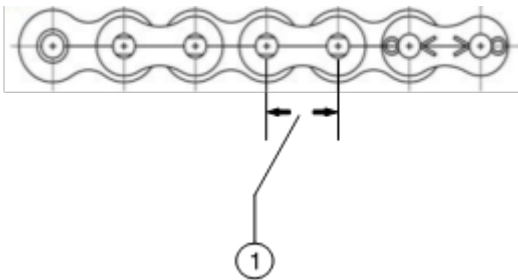

1 chain pitch

Note: For identification, this chain typically measures 3/4 inch between pin centers when new.

Note: Both the extend and retract chains should be measured.

Note: Measurement should be taken in the area where the chain articulates most frequently over the sheaves.

- ⊙ Result: The distance measures 12.36 inches / 313mm or less. The chain is within specifications. Continue with inspection.
- ⊗ Result: If the distance is greater than 12.36 inches / 313mm, the machine shall be removed from service until the chain is replaced.

Note: The boom chain's normal life expectancy can be expressed as a maximum percent of elongation of 3%.

GTH-1256 and GTH-1544 models

- Elongation

Note: The pitch of the boom extend chains (boom lower section) shall be 1 inch / 25.4 mm.

Note: The pitch of the boom retract chains (boom upper section) shall be 0.75 inches / 19.05 mm.

GTH-1256: Only the extend chains should be measured.

GTH-1544: Both the extend and retract chains should be measured.

Note: Measurement should be taken in the area where the chain articulates most frequently over the sheaves.

- ⊙ Result: The distance measures 1 inch / 25.4 mm (lower chain) or 0.75 inches / 19.05 mm (upper chain). The chain is within specification. Continue with inspection.
- ⊗ Result: The distance is greater than 1 inch / 25.4 mm (lower chain) or 0.75 inches / 19.05 mm. The machine shall be removed from service until the chain is replaced.

Note: The boom chain's normal life expectancy can be expressed as a maximum percent of elongation of 2%.

Note: Consult Product Support to know the correct procedure to better understand maximum percent of chain elongation.

Quarterly Maintenance Procedures

All models:

- **Edge wear:**

Check the chain for wear on the link plate edges caused by running back and forth over the sheave. The maximum reduction of material should not exceed 5%.

- **Cracked plates:**

Check link side plates for any cracks. These are generally a sign of chain fatigue.

- **Turning pins:**

Check the pins. The position of the riveting must be parallel with the top and bottom of the side plate.

If any of these conditions are discovered during the inspection, the chain must be replaced.

After inspection and before being returned to service, the chains must be lubricated with a quality chain lubricant.

Note: Do not use grease to lubricate chains.

The chain plates should be brushed with a wire brush prior to lubrication to clear the space between the plates.

The lubricant must penetrate the chain joint to prevent wear. Applying lubricant to the external surfaces will prevent rust, but the chains should be articulated to make sure the lubricant penetrates to the working surfaces between the pins and links.

Lubricant may be applied with a brush, sprayed or poured on, but the chain should be well flooded with lubricant and the boom should be extended and retracted to insure that the lubricant penetrates all working surfaces. All excess lubricant should be wiped away from the external surfaces.

Note: Do not use solvents to remove excess lubricant.

Annual Maintenance Procedures

A-1 Inspect the Forks



Genie specifications require that this procedure be performed annually. OR whenever permanent deformation of the forks is suspected.

Maintaining the lifting forks in good condition is essential to safe operation and good machine performance. Failure to detect damage to the forks could result in a hazardous operating condition.

- 1 Thoroughly clean the lifting forks.
- 2 Inspect the forks for the following:
 - Surface cracks
 - Straightness of the blade and shank
 - Fork angle at 90 ± 3 degrees
 - Relative height of fork tips shall not differ more than 3% of blade length

Fork	3% of blade length
48 in / 122 cm	1.44 in / 3,66 cm
60 in / 152,4 cm	1.8 in / 4,6 cm
72 in / 183 cm	2.16 in / 5,5 cm

- Excessive wear to the forks, fork mount or legible markings

⊗ Result: If any of the above criteria are not met, the fork must be removed from service until it is repaired or replaced.

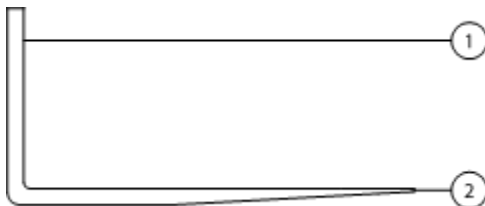

1 shank
2 blade

A-2 Adjust the Boom Sequencing Chains - GTH-636, GTH-844



Genie specifications require that this procedure be performed annually.

- 1 Raise the boom to the horizontal position.
- 2 Extend the boom fully, then retract the boom approximately 1 inch / 25 mm.
- 3 On either side of the middle boom section, estimate the center. Place one end of a tape measure on the top surface of the boom directly above the estimated center.
- 4 Select a reference point on the sequencing chain. Measure the distance between the chain and the top surface of the boom. Note the measurement (1). Refer to the following illustrations.

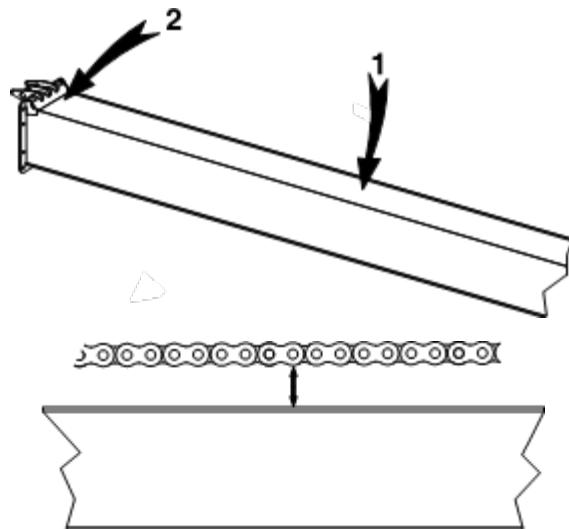

Annual Maintenance Procedures

- 5 Move to the fork end of the same boom section that was just measured.
- 6 Measure the distance between the top surface of the boom and the same reference point used on the sequencing chain in step 4. Note the measurement (2).
- ⊙ Result: The difference between measurements 1 and 2 is 0.25 - 0.5 inch / 6,35 - 12,7 mm. No adjustment to the chain is necessary. Proceed to step 10.
- ⊗ Result: The difference between measurements 1 and 2 is less than a 0.25 inch / 6,35 mm OR is greater than 0.5 inch / 12,7 mm. The chain requires adjustment. Proceed to step 7.

Note: The measurements taken in step 4 and step 6 must be taken from the same plane on the boom.

- 7 Working at the fork end of the large boom tube, locate the adjustable chain anchor on the top of boom section.
- 8 Place an adjustable wrench across the flat part of the chain, just ahead of the chain anchor. Tighten the wrench onto the chain.
- 9 Using a 1 7/16 inch wrench, adjust the nut as required to tighten or loosen the chain. Repeat this procedure for each chain beginning with step 4.

A-3

Adjust the Boom Sequencing Chains - GTH-1056



Genie specifications require that this procedure be performed annually.

- 1 Raise the boom to the horizontal position.
- 2 Extend the boom fully, then retract the boom approximately 1 inch / 25 mm.
- 3 Tie a string line on each end of the chain, being sure to pull the string taut.
- 4 At the midpoint of the string, measure the distance between the string and the chain surface corresponding to the surface the string line is attached to.
- ⊙ Result: The distance is 0.25 to 0.5 inch / 6.35 to 12.7 mm. No adjustment to the chain is necessary. Proceed to step 8.
- ⊗ Result: The distance is less than a 0.25 inch / 6.35 mm OR is greater than 0.5 inch / 12.7 mm. The chain requires adjustment. Proceed to step 5.
- 5 Working at the fork end of the large boom tube, locate the adjustable chain anchor on the top of the boom section.

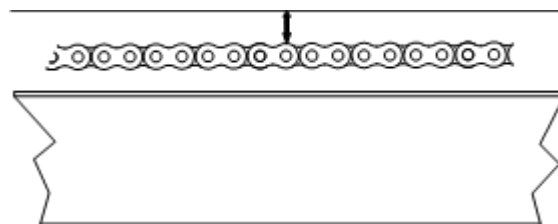

Annual Maintenance Procedures

- 6 Place an adjustable wrench across the flat part of the chain, just ahead of the chain anchor. Tighten the wrench onto the chain.
- 7 Using a 1 7/16 inch wrench, adjust the nut as required to tighten or loosen the chain. Repeat this procedure beginning with step 4 until the gap is between 0.25 to 0.5 inch / 6.35 to 12.7 mm.

Note: If the adjusting bolt runs out of threads before the chain tension is correct, the chain has stretched too far and the chain must be replaced.

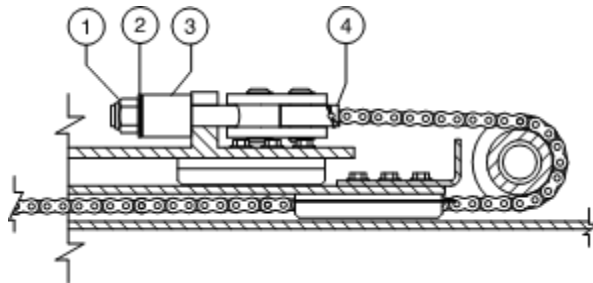

- 1 nut
- 2 washer
- 3 spacer
- 4 chain anchor

- 8 Fully retract the boom.
- 9 Measure the gap between the washer and the spacer. The gap should be between 0.125 to 0.25 inch / 3.2 mm to 6.35 mm.

A-4

Adjust the Boom Sequencing Chains - GTH-1256 and GTH-1544



Genie specifications require that this procedure be performed annually.

Extend chains (boom bottom side)

- 1 Raise the boom to horizontal position.
- 2 Fully extend the boom.
- 3 Retract it about 3.9 inches / 100 mm.
- 4 Tighten the chain up to a maximum tension value of 37 ft-lbs / 50 Nm.
- 5 Check that all chains have been equally tensioned. If not, repeat the operation described above.
- 6 Lock the chain tensioners by means of a conternut and locknut.

Retract chains (boom upper side)

- 1 Fully retract the boom.
- 2 Extend the boom by 11.8 inches / 300 mm.
- 3 Loosen the locker nut.
- 4 Tighten the tensioning nut to 37 ft-lbs / 50 Nm.
- 5 Tighten the locker nut.
- 6 Check that all chains have been equally tensioned. If not, repeat the operation described above.

Note: If during chain tensioning, problems are detected, please Genie Product Support.

Annual Maintenance Procedures

A-5 Replace Hydraulic Tank Return Filter Element



Genie specifications require that this procedure be performed annually.

Perform this procedure more often if dusty conditions exist.

Replacement of the hydraulic filters is essential for good machine performance and service life. A dirty or clogged filter may cause the machine to perform poorly and continued use may cause component damage. Extremely dirty conditions may require that the filter be replaced more often.



CAUTION Bodily injury hazard. Beware of hot oil. Contact with hot oil may cause severe burns.

Note: Perform this procedure with the engine off.

- 1 Locate the hydraulic tank return filter.

Note: Location and access may vary, depending on model.

- 2 Release the pressure in the oil reservoir by loosening the filler/breather cap.
- 3 Unscrew the return filter.
- 4 Install the new filter element.
- 5 Tighten the filler/breather cap.
- 6 Record the hours the filter element was replaced and keep with your maintenance records.
- 7 Start the engine.
- 8 Inspect the filter assembly to be sure that there are no leaks.
- 9 Clean up any oil that may have spilled during the installation procedure.

A-6 Replace the Cab Air Intake Filter Element (if equipped)



Genie specifications require that this procedure be performed annually.

Perform this procedure more often if dusty conditions exist.

Note: Location of the air intake access cover will vary, depending on specific models.

- 1 Remove the fasteners securing the cab air intake access cover and remove the cover.
- 2 Remove the air intake filter element.
- 3 Install the new filter element.
- 4 Re-install the cab air intake access cover.

Programmed Maintenance Procedures

P0-1

Lubricate the Boom



Genie specifications require that this procedure be performed every 8 hours or daily, whichever comes first.

Greasing the specified locations is essential for good machine performance and service life. Operating the machine with little or no grease may cause the machine to perform poorly and continued use may cause component damage.

- 1 Fully extend and raise the boom, then retract the boom, checking to insure it operates smoothly. There should be a light film of lubricant on wear pad contact surfaces.
 - ⦿ Result: Boom operates smoothly and a thin film of lubricant is visible. Proceed to step 6.
 - ⊗ Result: Boom does not extend or retract smoothly and no lubricant is visible on wear pad contact surfaces. Proceed to step 2.
- 2 GTH-1056 and GTH-1256 proceed to step 3. GTH-844, GTH-636 and GTH-5519 proceed to step 4.
- 3 Apply a thin layer of grease to the underside of the number 4 boom tube where it makes contact with the number 3 boom tube lower wear pads.

- 4 Apply a thin layer of grease to the underside of the number 3 boom tube where it makes contact with the number 1 boom tube lower wear pads.
- 5 Lubricate the top and side boom tube wear pads.
- 6 Return the boom to the stowed position.

Grease specification

EP NLGI 2 (lithium based) or equivalent

Lube-A-Boom grease, 7 lb pail
(recommended)

Genie part number 110147

Chevron Ultra-Duty EP 2 grease (alternate)

PTFE INTERFLON FIN GREASE LS 2

Genie part number 09.4693.0000

Programmed Maintenance Procedures

P0-2

Deutz Engine Maintenance – Under 1000 Hours

Additional engine maintenance is required. Refer to the *Programmed Maintenance Inspection Report* for the specific intervals that apply.

Required maintenance procedures and additional engine information are available in the manufacturer's manuals. Refer to Specifications, *Engine Operator and Maintenance Manuals*.

This maintenance schedule applies to the following Deutz Engines:

Deutz TD 2.9 L4

Deutz TCD 3.6 L4

Deutz TCD 4.1 L4

Deutz Engines		Hour Intervals			
		Procedure	Ø = Not required	Daily	250
Oil level - check				Ø	Ø
Coolant level - check				Ø	Ø
Oil, fuel and coolant systems - check for leaks				Ø	Ø
Fuel system filter/water separator – inspect/drain				Ø	Ø
Air filter discharge valve - clean				Ø	Ø
Engine tightness – check for leaks				Ø	Ø
Exhaust system - inspect				Ø	Ø
Fuel pre-cleaner / fuel pre-filter - clean			Ø		Ø
Cooling system- check			Ø		Ø
Engine oil and filter – replace			Ø	Ø	
Air filter - replace			Ø	Ø	
Valve clearance - check/adjust			Ø	Ø	
Engine coolant - test/add			Ø	Ø	
Air intake pipes - inspect			Ø	Ø	
V-belts - inspect			Ø	Ø	
Fuel filter / separator - replace			Ø	Ø	

Programmed Maintenance Procedures

P0-3

Perkins Engine Maintenance – Under 1000 Hours

Additional engine maintenance is required. Refer to the *Programmed Maintenance Inspection Report* for the specific intervals that apply.

Required maintenance procedures and additional engine information are available in the manufacturer's manuals. Refer to Specifications, *Engine Operator and Maintenance Manuals*.

This maintenance schedule applies to the following Perkins Engines:

Perkins 854E-E34TA Perkins 1104D-E44TA Perkins 1204E-E44TA

Perkins Engine		Hour Intervals		
Procedure	∅ = Not required	Daily	50	500
Oil level - check			∅	∅
Coolant level – check/add			∅	∅
Oil, fuel and coolant systems - check for leaks			∅	∅
Air filter discharge valve - clean			∅	∅
Fuel system filter/water separator – drain			∅	∅
Alternator belt - inspect/adjust/replace			∅	∅
V-belts - inspect/adjust/replace			∅	∅
Exhaust system - check for leaks			∅	∅
Fuel tank water/sediment - drain		∅		∅
Hoses and clamps – inspect/replace		∅		∅
Engine valve lash – inspect/adjust - 1104D-E44TA Models (initial one time service)		∅	∅	
Battery electrolyte level - check		∅	∅	
Cooling system supplement additive - test/add		∅	∅	
Engine oil and filter – replace		∅	∅	
Fuel system filter(s) - replace		∅	∅	
Radiator – clean		∅	∅	
Air cleaner element - clean/replace		∅	∅	
Fan clearance - check		∅	∅	

Programmed Maintenance Procedures

P0-4

John Deere Engine Maintenance – Under 1000 Hours

Additional engine maintenance is required. Refer to the *Programmed Maintenance Inspection Report* for the specific intervals that apply.

Required maintenance procedures and additional engine information are available in the manufacturer's manuals. Refer to Specifications, *Engine Operator and Maintenance Manuals*.

John Deere 4045TH485		Hour Intervals	
Procedure	∅ = Not required	Daily	500
Oil level - check			∅
Coolant level – check/add			∅
Fuel system filter/water separator – drain			∅
Air filter discharge valve - clean			∅
Oil, fuel and coolant systems - check for leaks			∅
Air cleaner - check			∅
Visual inspection of engine			∅
Engine oil - replace		∅	
Oil filter - replace		∅	
Engine mounts - inspect		∅	
Battery - check		∅	
Crankcase vent system - check		∅	
Air intake system - inspect		∅	
Cooling system - check		∅	
Engine ground - check		∅	
Air filter - replace		∅	
Engine belts - check/adjust/replace		∅	
Fuel system - check		∅	
Fuel filter - replace		∅	

Programmed Maintenance Procedures

P0-5

Axle Maintenance – Under 1000 Hours

Additional axle maintenance is required. Refer to the *Programmed Maintenance Inspection Report* for the specific intervals that apply.

Required maintenance procedures and additional transmission information are available in the manufacturer's manuals. Refer to Specifications, *Operator and Maintenance Manuals*.

Carraro 26.27M Axle		Hour Intervals		
Procedure	∅ = Not required	50	150	300
Oil level - check/add (initial, one-time interval)			∅	∅
Axle oil - change (initial, one-time interval)		∅		∅
Clean magnetic oil plugs (initial, one-time interval)		∅		∅
Oil breather - clean (initial, one-time interval)		∅		∅
Grease axle (initial, one-time interval)		∅		∅
Oil level - check/add		∅	∅	
Oil breather - clean		∅	∅	

Comer Axle		Hour Intervals		
Procedure	∅ = Not required	100	200	300
Differential lubricating oil - check/add (initial, one-time interval)			∅	∅
Planetary reduction lubricating oil - check/add (initial, one-time interval)			∅	∅
Differential lubricating oil - change (initial, one-time interval)		∅		∅
Planetary reduction lubricating oil - change (initial, one-time interval)		∅		∅
Magnetic plug - clean (initial, one-time interval)		∅		∅
Axle - grease		∅		∅
Differential lubricating oil - check/add		∅	∅	
Planetary reduction lubricating oil - check/add		∅	∅	
Oil breather - clean		∅	∅	

Programmed Maintenance Procedures

Dana Axles		Hour Intervals					
Procedure	\emptyset = Not required	Weekly	Monthly	100	200	500	800
King pin bearings and bushings - grease (severe duty perform daily)			\emptyset	\emptyset	\emptyset	\emptyset	\emptyset
Trunnion bushings - grease (severe duty perform daily)			\emptyset	\emptyset	\emptyset	\emptyset	\emptyset
Differential oil level - check		\emptyset		\emptyset	\emptyset	\emptyset	\emptyset
Differential oil - change (initial, one-time interval)		\emptyset	\emptyset		\emptyset	\emptyset	\emptyset
Hub oil - change (initial, one-time interval)		\emptyset	\emptyset		\emptyset	\emptyset	\emptyset
Differential lubricating oil - change (initial, one-time interval)		\emptyset	\emptyset		\emptyset	\emptyset	\emptyset
Planetary reduction lubricating oil - change (initial, one-time interval)		\emptyset	\emptyset		\emptyset	\emptyset	\emptyset
Negative brake - adjust (initial, one-time interval)		\emptyset	\emptyset		\emptyset	\emptyset	\emptyset
Hub oil - Check		\emptyset	\emptyset	\emptyset		\emptyset	\emptyset
Planetary reduction lubricating oil - check/add		\emptyset	\emptyset	\emptyset		\emptyset	\emptyset
Service brake - adjust		\emptyset	\emptyset	\emptyset	\emptyset		\emptyset
Differential oil - change		\emptyset	\emptyset	\emptyset	\emptyset	\emptyset	
Differential lubricating oil - change		\emptyset	\emptyset	\emptyset	\emptyset	\emptyset	

Programmed Maintenance Procedures

P0-6

Transmission Maintenance – Under 1000 Hours

Additional transmission maintenance is required. Refer to the *Programmed Maintenance Inspection Report* for the specific intervals that apply.

Required maintenance procedures and additional transmission information are available in the manufacturer's manuals. Refer to Specifications, *Operator and Maintenance Manuals*.

This maintenance schedule applies to the following transmissions:

Dana VDT12000 Dana TT20000 Dana Integral Gear Box Shift on Fly ZF 4 WG-98 TC

Transmissions		Hour Intervals	
Procedure	∅ = Not required	Daily	100
Transmission oil level - check/add*			∅
Drop box oil level - check/add			∅
Transmission filter - replace (initial, one-time interval)		∅	
Transmission oil - replace (initial, one-time interval)		∅	

*check oil with engine running at idle and oil at 180-200° F / 65-93° C

Programmed Maintenance Procedures

P1-1 Perform Engine Maintenance – 1000 Hours



Engine specifications require that this procedure be performed every 1000 hours.

Required maintenance procedures and additional engine information are available in the manufacturer's manuals. Refer to Specifications, *Engine Operator and Maintenance Manuals*.

Deutz Models

All Models:

- Charge air cooler entry area- drain lube oil/condensate
- Engine mounts- check
- Hose clamps and hoses- check
- V-rib belt and tensioning pulley- check
- Fuel filter cartridge - replace
- Fuel pre-filter - replace
- Filter insert for fuel pre-filter- replace
- Battery and cable connectors - check
- Cold starting device (if equipped) - check

Perkins Models

854E-E34TA, 1204E-E44TA

- Water pump - inspect
- Engine crankcase breather element - replace

1104D-E44TA

- Engine valve lash - inspect/adjust

P1-2 Perform Transmission Maintenance – 1000 Hours



Transmission specifications require that this procedure be performed every 1000 hours.

Required maintenance procedures and additional transmission information are available in the manufacturer's manuals. Refer to Specifications, *Operator and Maintenance Manuals*.

- Transmission oil and filter - replace
- Drop box (gearbox) - change oil

Programmed Maintenance Procedures

P1-3

Perform Axle Maintenance – 1000 Hours



Axle specifications require that this procedure be performed every 1000 hours.

Required maintenance procedures and additional axle information are available in the manufacturer's manuals. Refer to Specifications, *Operator and Maintenance Manuals*.

Dana Models

- Negative brake - adjust
- Hub oil level - change
- Planetary reduction lubricating oil - change

Carraro 26.27M Models

- Change axle oil 1500 hrs
- Clean magnetic oil plugs 1500 hrs

Comer Models

- Differential lubricating oil - change
- Planetary reduction lubricating oil - change
- Magnetic plug - clean

Programmed Maintenance Procedures

P2-1 Perform Engine Maintenance – 2000 Hours



Engine specifications require that this procedure be performed every 2000 hours.

Required maintenance procedures and additional engine information are available in the manufacturer's manuals. Refer to Specifications, *Engine Operator and Maintenance Manuals*.

Deutz Models

TCD 4.1 L4

- Valve clearance - setting
- V-belts - replace
- Exhaust gas recirculation, rods clearance - check/adjust
- Fuel pre-filter - replace
- Coolant - replace

Perkins Models

All models:

- Aftercooler core - inspect
- Engine mounts - inspect
- Starting motor - inspect
- Turbocharger - inspect

1104D-E44TA

- Water pump - inspect
- Belt tensioner - inspect

1104D-E44TA, 1204E-E44TA

- Alternator - inspect

John Deere

4045TH485

- Thermostats - test
- Engine valve clearance check and adjust
- Cooling system - flush and refill

Programmed Maintenance Procedures

P2-2

Test or Replace the Hydraulic Oil



Genie requires that this procedure be performed every 2000 hours.

Replacement or testing of the hydraulic oil is essential for good machine performance and service life. Dirty oil and a clogged suction strainer or hydraulic filters may cause the machine to perform poorly and continued use may cause component damage. Extremely dirty conditions may require oil changes to be performed more frequently.

Note: Before replacing the hydraulic oil, the oil may be tested by an oil distributor for specific levels of contamination to verify that changing the oil is necessary. If the hydraulic oil is not replaced at the 2000 hour inspection, test the oil quarterly. Replace the oil when it fails the test.

Note: When removing a hose assembly or fitting, the O-ring (if equipped) on the fitting and/or hose end must be replaced. All connections must be torqued to specification during installation. Refer to Specifications, *Hydraulic Hose and Fitting Torque Specifications*.

Testing the oil:

- 1 Complete the hydraulic oil testing with an oil distributor.
- ⦿ If the hydraulic oil passes testing at the 2000 hour maintenance interval, the oil must be tested every quarter by an oil distributor until the oil fails the test and is replaced.
- ⊗ If the hydraulic oil fails testing at the 2000 hour maintenance interval, the oil must be replaced. After the oil has been replaced, continue the scheduled quarterly maintenance inspection.

Replacing the hydraulic oil:

- 1 Remove the drain plug from the hydraulic tank and completely drain the tank into a container of suitable capacity. Refer to Specifications, *Hydraulic Fluid Capacities Specifications*.
- 2 Fill the tank with the proper hydraulic oil for your machine. Refer to Specifications, *Hydraulic Specifications*.
- 3 **Engine Models:** Prime the pump. Refer to Repair Procedure in the appropriate Service and Repair Manual for your machine, *How to Prime the Pump*.
- 4 Clean up and properly dispose of any oil that may have spilled.

Note: When replacing the hydraulic oil, it is recommended that the hydraulic tank be cleaned using a mild solvent and all hydraulic filters and strainers be replaced.

Note: Always use pipe thread sealant when installing the suction hose fittings and the drain plug.

Note: After the oil has been replaced, continue the scheduled quarterly maintenance inspection.

Programmed Maintenance Procedures

P3-1 Perform Engine Maintenance – 3000 Hours



Engine specifications require that this procedure be performed every 3000 hours.

Required maintenance procedures and additional engine information are available in the manufacturer's manuals. Refer to Specifications, *Engine Operator and Maintenance Manuals*.

Deutz Models

TD 2.9 L4, TCD3.6 L4

- V-rib belt and tensioning pulley- replace

Perkins Models

All Models:

- Alternator Belt - Inspect/Adjust/Replace
- Cooling system coolant - change

854E-E34TA

- Alternator - inspect
- Diesel Particulate Filter - clean
- Radiator Pressure Cap - clean/replace

1204E-E44TA

- Radiator Pressure Cap - clean/replace
- Belt tensioner - inspect

P4-1 Perform Engine Maintenance – 4000 Hours



Engine specifications require that this procedure be performed every 4000 hours.

Required maintenance procedures and additional engine information are available in the manufacturer's manuals. Refer to Specifications, *Engine Operator and Maintenance Manuals*.

Deutz Models

TCD 4.1 L4

- Flatter valve - replace
- V-rib belt and tensioning pulley - replace
- Spark plug of the DPF burner - replace

Perkins Models

All Models:

- Aftercooler Core - Clean/Test

John Deere 4045HF485 - 4500 Hours

- Crankshaft damper - replace

Programmed Maintenance Procedures

P6-1 Perform Engine Maintenance – 6000 Hours



Engine specifications require that this procedure be performed every 6000 hours.

Required maintenance procedures and additional engine information are available in the manufacturer's manuals. Refer to Specifications, *Engine Operator and Maintenance Manuals*.

Deutz Models

TCD 4.1 L4

- Crankcase breather valve - replace

P12-1 Perform Engine Maintenance – 12000 Hours



Engine specifications require that this procedure be performed every 12000 hours.

Required maintenance procedures and additional engine information are available in the manufacturer's manuals. Refer to Specifications, *Engine Operator and Maintenance Manuals*.

Perkins Models

854E-E34TA, 1104D-E44TA, 1204E-E44TA

- Cooling System Coolant (Extended life coolant) - change

California Proposition 65



Operating, servicing and maintaining this equipment can expose you to chemicals including engine exhaust, carbon monoxide, phthalates, and lead, which are known to the State of California to cause cancer and birth defects or other reproductive harm. These chemicals can be emitted from or contained in other various parts and systems, fluids and some component wear by-products. To minimize exposure, avoid breathing exhaust, do not idle the engine except as necessary, service your equipment and vehicle in a well-ventilated area and wear gloves or wash your hands frequently when servicing your equipment or vehicle and after operation. For more information go to www.P65Warnings.ca.gov/passenger-vehicle.

Breathing diesel engine exhaust exposes you to chemicals known to the State of California to cause cancer and birth defects or other reproductive harm.

- Always start and operate the engine in a well-ventilated area.
- If in an enclosed area, vent the exhaust to the outside.
- Do not modify or tamper with the exhaust system.
- Do not idle the engine except as necessary.

For more information go to www.P65warnings.ca.gov/diesel.