



Service Manual

Serial Number Range

TZ™-34/20

from TZ3403-001
to TZ3413-595

Part No. 84382

Rev D1

August 2022

Introduction

Important

Read, understand and obey the safety rules and operating instructions in the appropriate operator's manual on your machine before attempting any maintenance or repair procedure.

This manual provides detailed scheduled maintenance information for the machine owner and user. It also provides troubleshooting fault codes and repair procedures for qualified service professionals.

Basic mechanical, hydraulic and electrical skills are required to perform most procedures. However, several procedures require specialized skills, tools, lifting equipment and a suitable workshop. In these instances, we strongly recommend that maintenance and repair be performed at an authorized Genie dealer service center.

Compliance

Machine Classification

Group B/Type 3 as defined by ISO 16368

Machine Design Life

Unrestricted with proper operation, inspection and scheduled maintenance.

Technical Publications

Genie has endeavored to deliver the highest degree of accuracy possible. However, continuous improvement of our products is a Genie policy. Therefore, product specifications are subject to change without notice.

Readers are encouraged to notify Genie of errors and send in suggestions for improvement. All communications will be carefully considered for future printings of this and all other manuals.

Contact Us:

<http://www.genielift.com>
e-mail: awp.techpub@terex.com

Copyright © 2011 Terex Corporation

84382 Rev D June 2013
First Edition, Fourth Printing

Genie is a registered trademarks of Terex South Dakota, Inc. in the USA and many other countries.

"TZ" is a trademark of Terex South Dakota, INC.

 Printed on recycled paper

Printed in U.S.A.



Revision History

Revision	Date	Section	Procedure / Schematic Page / Description
A	11/2004		New release
D	6/2013	Introduction	Revision History Added
		2 - Spec.	Hydraulic Specifications SAE and Metric Fastener Torque Chart
		3 - Maint.	Added specific maintenance to all axle procedures. Revised procedures.
		4 - Repair	Revised procedures.
		5 - Schem.	Revised all schematics and grouped by market
D1	8/2022	4 - Repair	6-2
REFERENCE EXAMPLES:			
Honda Engine_Section 2_Specifications. A-6,B-3,C-7_Section 3_Maintenance Procedure. 3-2, 6-4, 9-1_Section 4_Repair Procedure. 5-35, 5-56, 5-104_Section 5_Schematic Page #.			



REVISION HISTORY, CONTINUED

Revision	Date	Section	Procedure / Schematic Page / Description
REFERENCE EXAMPLES:			
<p>Honda Engine_Section 2_Specifications. A-6,B-3,C-7_Section 3_Maintenance Procedure. 3-2, 6-4, 9-1_Section 4_Repair Procedure. 5-35, 5-56, 5-104_Section 5_Schematic Page #.</p>			<p><u>Electronic Version</u></p> <p>Click on any procedure or page number highlighted in blue to view the update.</p>



Safety Rules



Danger

Failure to obey the instructions and safety rules in this manual and the appropriate Operator's Manual on your machine will result in death or serious injury.

Many of the hazards identified in the operator's manual are also safety hazards when maintenance and repair procedures are performed.

Do not modify or alter a MEWP without prior written permission from the manufacture.

Do Not Perform Maintenance Unless:

- ☑ You are trained and qualified to perform maintenance on this machine.
- ☑ You read, understand and obey:
 - manufacturer's instructions and safety rules
 - employer's safety rules and worksite regulations
 - applicable governmental regulations
- ☑ You have the appropriate tools, lifting equipment and a suitable workshop.

Personal Safety

Any person working on or around a machine must be aware of all known safety hazards. Personal safety and the continued safe operation of the machine should be your top priority.



Read each procedure thoroughly. This manual and the decals on the machine, use signal words to identify the following:



Safety alert symbol—used to alert personnel to potential personal injury hazards. Obey all safety messages that follow this symbol to avoid possible injury or death.

▲ DANGER

Indicates an imminently hazardous situation which, if not avoided, will result in death or serious injury.

▲ WARNING

Indicates a potentially hazardous situation which, if not avoided, could result in death or serious injury.

▲ CAUTION

Indicates a potentially hazardous situation which, if not avoided, may cause minor or moderate injury.

NOTICE

Indicates a potentially hazardous situation which, if not avoided, may result in property damage.



Be sure to wear protective eye wear and other protective clothing if the situation warrants it.



Be aware of potential crushing hazards such as moving parts, free swinging or unsecured components when lifting or placing loads. Always wear approved steel-toed shoes.

SAFETY RULES

Workplace Safety



Be sure to keep sparks, flames and lighted tobacco away from flammable and combustible materials like battery gases and engine fuels. Always have an approved fire extinguisher within easy reach.



Be sure that all tools and working areas are properly maintained and ready for use. Keep work surfaces clean and free of debris that could get into machine components and cause damage.



Be sure any forklift, overhead crane or other lifting or supporting device is fully capable of supporting and stabilizing the weight to be lifted. Use only chains or straps that are in good condition and of ample capacity.



Be sure that fasteners intended for one time use (i.e., cotter pins and self-locking nuts) are not reused. These components may fail if they are used a second time.



Be sure to properly dispose of old oil or other fluids. Use an approved container. Please be environmentally safe.



Be sure that your workshop or work area is properly ventilated and well lit.

Table of Contents

Introduction

Important Information	<i>ii</i>
Revision History	<i>iii</i>
Serial Number Legend	<i>v</i>

Section 1 **Safety Rules**

General Safety Rules	<i>iv</i>
----------------------------	-----------

Section 2 **Specifications**

Machine Specifications	2 - 1
Performance Specifications	2 - 2
Hydraulic Specifications	2 - 2
Manifold Component Specifications	2 - 3
Hydraulic Hose and Fitting Torque Specifications	2 - 4
SAE and Metric Fastener Torque Chart	2 - 6

Section 3 **Scheduled Maintenance Procedures**

Introduction	3 - 1
Pre-delivery Preparation Report	3 - 3
Maintenance Inspection Report	3 - 5
Checklist A Procedures	
A-1 Inspect the Manuals and Decals	3 - 6
A-2 Perform Pre-operation Inspection	3 - 7
A-3 Perform Function Tests	3 - 7
A-4 Torque the Lug Bolts - ANSI/CSA/AS	3 - 7
A-5 Torque the Lug Bolts - CE	3 - 8

Section 3 **Scheduled Maintenance Procedures**, continued

A-6 Perform Hitch Maintenance - ANSI/CSA/AS 3 - 8

A-7 Perform 30 Day Service 3 - 9

A-8 Grease the Turntable Rotation Bearing and Rotate Gear 3 - 9

Checklist B Procedures

B-1 Inspect the Batteries 3 - 10

B-2 Inspect the Electrical Wiring 3 - 11

B-3 Inspect the Electrical Contactor 3 - 11

B-4 Test the Emergency Stop 3 - 12

B-5 Test the Key Switch 3 - 12

B-6 Test the Manual Override 3 - 13

B-7 Test the Platform Rotation (if equipped) 3 - 17

B-8 Perform Hydraulic Oil Analysis 3 - 17

B-9 Perform Axle Maintenance - ANSI/CSA/AS 3 - 18

B-10 Check the Wheel Bearings - CE 3 - 18

B-11 Service the Hitch - CE 3 - 19

B-12 Perform Axle Maintenance - CE 3 - 19

B-13 Inspect the Parking Brake 3 - 20

B-14 Service the Tongue Jack 3 - 20

Checklist C Procedures

C-1 Grease the Platform Overload Mechanism (if equipped) 3 - 21

C-2 Test the Platform Overload System (if equipped) 3 - 21

C-3 Perform Axle Maintenance - ANSI/CSA/AS 3 - 23

 TABLE OF CONTENTS

Section 3	Scheduled Maintenance Procedures, continued	
C-4	Replace the Hydraulic Tank Breather Cap Models with Optional Hydraulic Oil	3 - 23
C-5	Grease the Axle Wheel Bearings - CE	3 - 24
C-6	Adjust the Brakes - CE	3 - 25
	Checklist D Procedures	
D-1	Perform Axle Maintenance - ANSI/CSA/AS	3 - 26
D-2	Check the Boom Wear Pads	3 - 26
D-3	Replace the Hydraulic Tank Return Filter	3 - 27
D-4	Check the Turntable Rotation Bearing Bolts	3 - 28
D-5	Inspect for Turntable Bearing Wear	3 - 29
	Checklist E Procedure	
E-1	Test or Replace the Hydraulic Oil	3 - 31
Section 4	Repair	
	Introduction	4 - 1
	Platform Components	
1-1	Platform	4 - 2
1-2	Platform Rotator (if equipped)	4 - 2
	Primary Boom Components	
2-1	Cable Track	4 - 7
2-2	Primary Boom	4 - 9
2-3	Primary Boom Lift Cylinder	4 - 13
2-4	Platform Leveling Cylinders	4 - 14
	Secondary Boom Components	
3-1	Secondary Boom	4 - 17
3-2	Secondary Boom Lift Cylinder	4 - 19
	Ground Controls	
4-1	Level Sensor	4 - 20

Section 4	Repair, continued	
	Hydraulic Power Unit	
5-1	Hydraulic Power Unit Components (to serial number TZ3412-298)	4 - 24
5-2	Hydraulic Power Unit Components (from serial number TZ3412-299)	4 - 26
5-3	Valve Adjustments - Hydraulic Power Unit	4 - 28
5-4	Hydraulic Pump	4 - 29
	Manifolds	
6-1	Function Manifold Components (to serial number TZ3403-248)	4 - 30
6-2	Function Manifold Components (from serial number TZ3403-249 to TZ3405-171)	4 - 32
6-3	Function Manifold Components (from serial number TZ3405-172)	4 - 34
6-4	Outrigger Counterbalance Valve Manifold Components (from serial number TZ3412-299)	4 - 36
6-5	Valve Coils	4 - 37
	Turntable Rotation Components	
7-1	Turntable Rotation Motor	4 - 39
	Axle Components	
8-1	Axle	4 - 40
	Trailer Components	
9-1	Hydraulic and Mechanical Brakes	4 - 41
9-2	Parking Brake	4 - 41
	Outriggers	
10-1	Outrigger Components	4 - 42
10-2	Outrigger Cylinder	4 - 43
	Platform Overload Components	
11-1	Platform Overload System	4 - 44

TABLE OF CONTENTS

Section 5	Schematics	
	Introduction	5 - 1
	Electrical Abbreviations Legend	5 - 2
	Wire Color Legend	5 - 4
	Limit Switch Legend	5 - 5
	Electrical Symbols Legend	5 - 6
	Hydraulic Abbreviations Legend	5 - 7
	Hydraulic Symbols Legend	5 - 8
	Trailer Lighting Wiring Diagram - ANSI/CSA	5 - 9
	Trailer Lighting Wiring Diagram - Mechanical Axle, CE (to serial number TZ3412-193)	5 - 10
	Trailer Lighting Wiring Diagram - Mechanical Axle, CE (from serial number TZ3412-194)	5 - 11
	Trailer Lighting Wiring Diagram - Hydraulic Axle, AS (from serial number TZ3412-193)	5 - 12

Section 5 Schematics, continued

Control Box Wiring Diagrams - ANSI/CSA

Ground Control Box Wiring Diagram - ANSI/CSA
 (to serial number TZ3403-185) 5 - 14

Ground Control Box Wiring Diagram - ANSI/CSA
 (from serial number TZ3403-186 to TZ3403-248) 5 - 16

Ground Control Box Wiring Diagram - ANSI/CSA
 (from serial number TZ3403-249 to TZ3404-303) 5 - 18

Ground Control Box Wiring Diagram - ANSI/CSA
 (from serial number TZ3404-304 to TZ3404-505) 5 - 20

Ground Control Box Wiring Diagram - ANSI/CSA
 (from serial number TZ3404-506 to TZ3405-189) 5 - 22

Ground Control Box Wiring Diagram - ANSI/CSA
 (from serial number TZ3405-190 to TZ3406-204) 5 - 24

Ground Control Box Wiring Diagram - ANSI/CSA
 (from serial number TZ3406-205) 5 - 26

Platform Control Box Wiring Diagram - ANSI/CSA
 (to serial number TZ3403-185) 5 - 28

Platform Control Box Wiring Diagram - ANSI/CSA
 (from serial number TZ3403-186 to TZ3403-248) 5 - 29

Platform Control Box Wiring Diagram - ANSI/CSA
 (from serial number TZ3403-249 to TZ3404-303) 5 - 30

Platform Control Box Wiring Diagram - ANSI/CSA
 (from serial number TZ3404-304 to TZ3406-204) 5 - 31

Platform Control Box Wiring Diagram - ANSI/CSA
 (from serial number TZ3406-205) 5 - 32

TABLE OF CONTENTS

Section 5 **Schematics, continued**

Control Box Wiring Diagrams - AS/CE

 Ground Control Box Wiring Diagram - AS/CE
 (to serial number TZ3404-303) 5 - 34

 Ground Control Box Wiring Diagram - AS/CE
 (from serial number TZ3404-304 to TZ3404-505) 5 - 36

 Ground Control Box Wiring Diagram - AS/CE
 (from serial number TZ3404-506 to TZ3405-189) 5 - 38

 Ground Control Box Wiring Diagram - AS/CE
 (from serial number TZ3405-190 to TZ3406-204) 5 - 40

 Ground Control Box Wiring Diagram - AS/CE
 (from serial number TZ3406-205) 5 - 42

 Platform Control Box Wiring Diagrams - AS/CE
 (to serial number TZ3404-303) 5 - 44

 Platform Control Box Wiring Diagrams - AS/CE
 (from serial number TZ3404-304 to TZ3406-204) 5 - 45

 Platform Control Box Wiring Diagrams - AS/CE
 (from serial number TZ3406-205 to TZ3410-144) 5 - 46

 Platform Control Box Wiring Diagrams - AS/CE
 (from serial number TZ3410-145) 5 - 47

Section 5 **Schematics, continued**

Electrical Schematics - ANSI/CSA

Electrical Schematic - ANSI/CSA (to serial number TZ3403-185)	5 - 50
Electrical Schematic - ANSI/CSA (from serial number TZ3403-186 to TZ3403-248)	5 - 54
Electrical Schematic - ANSI/CSA (from serial number TZ3403-249 to TZ3404-303)	5 - 58
Electrical Schematic - ANSI/CSA (from serial number TZ3404-304 to TZ3405-189)	5 - 62
Electrical Schematic - ANSI/CSA (from serial number TZ3405-190 to TZ3406-204)	5 - 66
Electrical Schematic - ANSI/CSA (from serial number TZ3406-205 to TZ3411-358)	5 - 70
Electrical Schematic - ANSI/CSA (from serial number TZ3411-359 to TZ3412-344)	5 - 74
Electrical Schematic - ANSI/CSA (from serial number TZ3413-345)	5 - 78

TABLE OF CONTENTS

Section 5 Schematics, continued

Electrical Schematics - AS/CE

Electrical Schematic - AS/CE
 (to serial number TZ3404-303) 5 - 82

Electrical Schematic - AS/CE
 (from serial number TZ3404-304 to TZ3405-189) 5 - 86

Electrical Schematic - AS/CE
 (from serial number TZ3405-190 to TZ3406-204) 5 - 90

Electrical Schematic - AS/CE
 (from serial number TZ3406-205 to TZ3411-358) 5 - 94

Electrical Schematic - AS/CE
 (from serial number TZ3411-359 to TZ3413-344) 5 - 98

Electrical Schematic - AS/CE
 (from serial number TZ3413-345) 5 - 102

Hydraulic Schematics

Hydraulic Schematic (to serial number TZ3403-248) 5 - 106

Hydraulic Schematic (from serial number TZ3403-249 to TZ3405-171) 5 - 107

Hydraulic Schematic (from serial number TZ3405-172 to TZ3412-298) 5 - 110

Hydraulic Schematic (from serial number TZ3412-299) 5 - 111

Specifications

Machine Specifications

Batteries

Type	6V DC
Group	T-105
Quantity	4
Battery capacity	225AH
Reserve capacity @ 25A rate	447 minutes

Fluid capacities

To TZ3407-483	
Hydraulic tank	2.2 gallons 8.4 liters
Hydraulic system (including tank)	3.9 gallons 14.8 liters
From TZ3407-484	
Hydraulic tank	2.8 gallons 10.6 liters
Hydraulic system (including tank)	4.5 gallons 17 liters

Tires and wheels - ANSI/CSA/AS

Axle

Tire size	ST205/75 R14
Load range	C
Lug nut torque, dry	100 ft-lbs 135 Nm
Tire pressure, maximum (cold)	50 psi 3.4 bar

Tongue jack

Tire size	4.10 / 3.50-4
Tire pressure, maximum (cold)	50 psi 3.4 bar

Tires and wheels - CE

Axle

Tire size	185 R14C 104/102N
Lug bolt torque, dry	66 ft-lbs 90 Nm
Tire pressure, maximum (cold)	65 psi 4.5 bar

Tongue jack

Tire size	8 x 2
-----------	-------

For operational specifications, refer to the Operator's Manual.

Continuous improvement of our products is a Genie policy. Product specifications are subject to change without notice.



SPECIFICATIONS

Performance Specifications**Boom function speeds, maximum from platform controls**
(no weight in platform)

Primary boom up	14 to 22 seconds
Primary boom down	24 to 32 seconds
Primary boom extend	18 to 28 seconds
Primary boom retract	18 to 28 seconds
Secondary boom up	14 to 24 seconds
Secondary boom down	14 to 24 seconds
Turntable rotate - 359°	80 to 115 seconds
Airborne noise emissions Maximum sound level at normal operation workstations (A-weighted)	80 dB

Hydraulic Specifications**Hydraulic Oil Specifications**

Hydraulic oil type	Chevron Rando HD equivalent
Viscosity grade	Multi-viscosity
Viscosity index	200
Cleanliness level, minimum	15/13
Water content, maximum	200 ppm

Chevron Rando HD oil is fully compatible and mixable with Shell Donax TG (Dexron III) oils.

Genie specifications require hydraulic oils which are designed to give maximum protection to hydraulic systems, have the ability to perform over a wide temperature range, and the viscosity index should exceed 140. They should provide excellent antiwear, oxidation, corrosion inhibition, seal conditioning, and foam and aeration suppression properties.

Optional fluids

Biodegradable	Petro Canada Environ MV 46 Statoil Hydra Way Bio Pa 32 BP Biohyd SE-S
Fire resistant	UCON Hydrolube HP-5046 Quintolubric 822
Mineral based	Shell Tellus S2 V 32 Shell Tellus S2 V 46 Chevron Aviation A Arnica 32

NOTICE

Continued use of Chevron Aviation A hydraulic fluid when ambient temperatures are consistently above 32°F / 0°C may result in component damage.

Note: Use Chevron Aviation A hydraulic fluid when ambient temperatures are consistently below 0°F / -17°C.

Note: Use Shell Tellus S2 V 46 hydraulic oil when oil temperatures consistently exceed 205°F / 96°C.

Note: Genie specifications require additional equipment and special installation instructions for the approved optional fluids. Consult the Genie Service Department before use.

Continuous improvement of our products is a Genie policy. Product specifications are subject to change without notice.

SPECIFICATIONS

Function pump - To TZ3407-483

Displacement per revolution	0.122 cu in 2.0 cc
Flow rate @ 3500 rpm	1.65 gallons per minute 6.25 liters per minute

Function pump - From TZ3407-484

Displacement per revolution	0.101 cu in 1.66 cc
Flow rate @ 3500 rpm	1.3 gallons per minute 4.9 liters per minute

Relief Valve Pressures

System relief valve pressure	3500 psi 241.3 bar
Outrigger relief valve pressure	4000 psi 275.8 bar
Turntable rotate relief valve pressure	1200 psi 82.7 bar
Boom extend relief valve pressure	1800 psi 124.1 bar
Primary boom lift cylinder relief valve pressure	1600 psi 110.3 bar
Secondary boom lift cylinder relief valve pressure	1100 psi 75.8 bar

Manifold Component Specifications**Plug torque**

SAE No. 2	50 in-lbs / 6 Nm
SAE No. 4	13 ft-lbs / 18 Nm
SAE No. 6	18 ft-lbs / 24 Nm
SAE No. 8	50 ft-lbs / 68 Nm
SAE No. 10	55 ft-lbs / 75 Nm
SAE No. 12	75 ft-lbs / 102 Nm

Valve Coil Resistance

Description	Specification
Solenoid valve, 3 position 4 way 24V DC with diode (schematic item B, AA, AB, AC, AD and AE)	29 to 31 Ω
Solenoid valve, 3 position 4 way 24V DC with diode (schematic items K, M, Q and T)	20 to 22 Ω
Solenoid valve, 2 position 3 way 24V DC with diode (schematic items O and V)	29 to 31 Ω
Solenoid valve, 2 position 2 way, N.C. 24V DC with diode (schematic items W, X, Y and Z)	29 to 31 Ω

Continuous improvement of our products is a Genie policy. Product specifications are subject to change without notice.



SPECIFICATIONS

Hydraulic Hose and Fitting Torque Specifications

Your machine is equipped with Parker Seal-Lok™ ORFS or 37° JIC fittings and hose ends. Genie specifications require that fittings and hose ends be torqued to specification when they are removed and installed or when new hoses or fittings are installed.

Seal-Lok™ Fittings (hose end - ORFS)

SAE Dash size	Torque
-4	10 ft-lbs / 13.6 Nm
-6	30 ft-lbs / 40.7 Nm
-8	40 ft-lbs / 54.2 Nm
-10	60 ft-lbs / 81.3 Nm
-12	85 ft-lbs / 115 Nm
-16	110 ft-lbs / 150 Nm
-20	140 ft-lbs / 190 Nm
-24	180 ft-lbs / 245 Nm

JIC 37° Fittings (swivel nut or hose connection)

SAE Dash size	Thread Size	Flats
-4	7/16-20	2
-6	9/16-18	1 1/4
-8	3/4-16	1
-10	7/8-14	1
-12	1 1/16-12	1
-16	1 5/16-12	1
-20	1 5/8-12	1
-24	1 7/8-12	1

SAE O-ring Boss Port (tube fitting - installed into Aluminum) (all types)

SAE Dash size	Torque
-4	14 ft-lbs / 19 Nm
-6	23 ft-lbs / 31.2 Nm
-8	36 ft-lbs / 54.2 Nm
-10	62 ft-lbs / 84 Nm
-12	84 ft-lbs / 114 Nm
-16	125 ft-lbs / 169.5 Nm
-20	151 ft-lbs / 204.7 Nm
-24	184 ft-lbs / 249.5 Nm

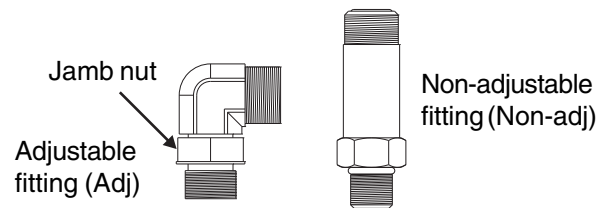

SAE O-ring Boss Port (tube fitting - installed into Steel)

SAE Dash size	Torque
-4 ORFS / 37° (Adj)	15 ft-lbs / 20.3 Nm
ORFS (Non-adj)	26 ft-lbs / 35.3 Nm
37° (Non-adj)	22 ft-lbs / 30 Nm
-6 ORFS (Adj / Non-adj)	35 ft-lbs / 47.5 Nm
37° (Adj / Non-adj)	29 ft-lbs / 39.3 Nm
-8 ORFS (Adj / Non-adj)	60 ft-lbs / 81.3 Nm
37° (Adj / Non-adj)	52 ft-lbs / 70.5 Nm
-10 ORFS (Adj / Non-adj)	100 ft-lbs / 135.6 Nm
37° (Adj / Non-adj)	85 ft-lbs / 115.3 Nm
-12 (All types)	135 ft-lbs / 183 Nm
-16 (All types)	200 ft-lbs / 271.2 Nm
-20 (All types)	250 ft-lbs / 339 Nm
-24 (All types)	305 ft-lbs / 413.5 Nm

SPECIFICATIONS

Torque Procedure

Seal-Lok™ fittings

- 1 Replace the O-ring. The O-ring must be replaced anytime the seal has been broken. The O-ring cannot be re-used if the fitting or hose end has been tightened beyond finger tight.

Note: The O-rings used in the Parker Seal Lok™ fittings and hose ends are custom-size O-rings. They are not standard SAE size O-rings. They are available in the O-ring field service kit (Genie part number 49612).

- 2 Lubricate the O-ring before installation.
- 3 Be sure that the face seal O-ring is seated and retained properly.
- 4 Position the tube and nut squarely on the face seal end of the fitting and tighten the nut finger tight.
- 5 Tighten the nut or fitting to the appropriate torque per given size as shown in the table.
- 6 Operate all machine functions and inspect the hoses and fittings and related components to confirm that there are no leaks.

JIC 37° fittings

- 1 Align the tube flare (hex nut) against the nose of the fitting body (body hex fitting) and tighten the hex nut to the body hex fitting to hand-tight, approximately 30 in-lbs / 3.4 Nm.
- 2 Make a reference mark on one of the flats of the hex nut, and continue it on to the body hex fitting with a permanent ink marker. Refer to Figure 1.

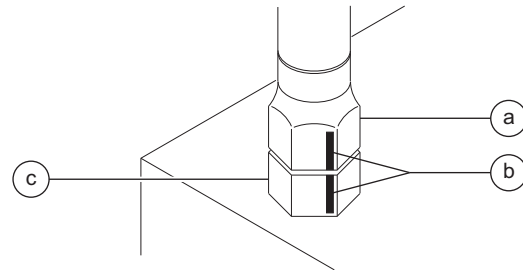

Figure 1

- a hex nut
- b reference mark
- c body hex fitting

- 3 Working clockwise on the body hex fitting, make a second mark with a permanent ink marker to indicate the proper tightening position. Refer to Figure 2.

Note: Use the *JIC 37° Fittings* table on the previous page to determine the correct number of flats for the proper tightening position.

Note: The marks indicate that the correct tightening positions have been determined. Use the second mark on the body hex fitting to properly tighten the joint after it has been loosened.

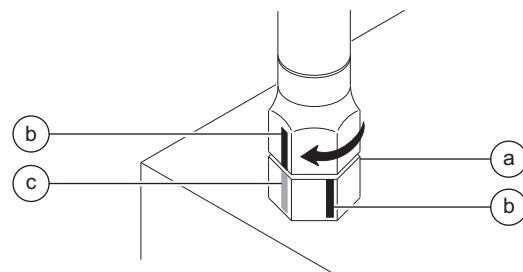



Figure 2

- a body hex fitting
- b reference mark
- c second mark





- 4 Tighten the hex nut until the mark on the hex nut is aligned with the second mark on the body hex fitting.
- 5 Operate all machine functions and inspect the hoses and fittings and related components to confirm that there are no leaks.

SPECIFICATIONS

SAE FASTENER TORQUE CHART
 • This chart is to be used as a guide only unless noted elsewhere in this manual •

SIZE	THREAD	Grade 5 				Grade 8 				A574 High Strength Black Oxide Bolts	
		LUBED		DRY		LUBED		DRY		LUBED	
		in-lbs	Nm	in-lbs	Nm	in-lbs	Nm	in-lbs	Nm	in-lbs	Nm
1/4	20	80	9	100	11.3	110	12.4	140	15.8	130	14.7
	28	90	10.1	120	13.5	120	13.5	160	18	140	15.8
		LUBED		DRY		LUBED		DRY		LUBED	
		ft-lbs	Nm	ft-lbs	Nm	ft-lbs	Nm	ft-lbs	Nm	ft-lbs	Nm
5/16	18	13	17.6	17	23	18	24	25	33.9	21	28.4
	24	14	19	19	25.7	20	27.1	27	36.6	24	32.5
3/8	16	23	31.2	31	42	33	44.7	44	59.6	38	51.5
	24	26	35.2	35	47.4	37	50.1	49	66.4	43	58.3
7/16	14	37	50.1	49	66.4	50	67.8	70	94.7	61	82.7
	20	41	55.5	55	74.5	60	81.3	80	108.4	68	92.1
1/2	13	57	77.3	75	101.6	80	108.4	110	149	93	126
	20	64	86.7	85	115	90	122	120	162	105	142
9/16	12	80	108.4	110	149	120	162	150	203	130	176
	18	90	122	120	162	130	176	170	230	140	189
5/8	11	110	149	150	203	160	217	210	284	180	244
	18	130	176	170	230	180	244	240	325	200	271
3/4	10	200	271	270	366	280	379	380	515	320	433
	16	220	298	300	406	310	420	420	569	350	474
7/8	9	320	433	430	583	450	610	610	827	510	691
	14	350	474	470	637	500	678	670	908	560	759
1	8	480	650	640	867	680	922	910	1233	770	1044
	12	530	718	710	962	750	1016	990	1342	840	1139
1 1/8	7	590	800	790	1071	970	1315	1290	1749	1090	1477
	12	670	908	890	1206	1080	1464	1440	1952	1220	1654
1 1/4	7	840	1138	1120	1518	1360	1844	1820	2467	1530	2074
	12	930	1260	1240	1681	1510	2047	2010	2725	1700	2304
1 1/2	6	1460	1979	1950	2643	2370	3213	3160	4284	2670	3620
	12	1640	2223	2190	2969	2670	3620	3560	4826	3000	4067

METRIC FASTENER TORQUE CHART
 • This chart is to be used as a guide only unless noted elsewhere in this manual •

Size (mm)	Class 4.6 				Class 8.8 				Class 10.9 				Class 12.9 			
	LUBED		DRY		LUBED		DRY		LUBED		DRY		LUBED		DRY	
	in-lbs	Nm	in-lbs	Nm	in-lbs	Nm	in-lbs	Nm	in-lbs	Nm	in-lbs	Nm	in-lbs	Nm	in-lbs	Nm
5	16	1.8	21	2.4	41	4.63	54	6.18	58	6.63	78	8.84	68	7.75	91	10.3
6	19	3.05	36	4.07	69	7.87	93	10.5	100	11.3	132	15	116	13.2	155	17.6
7	45	5.12	60	6.83	116	13.2	155	17.6	167	18.9	223	25.2	195	22.1	260	29.4
	LUBED		DRY		LUBED		DRY		LUBED		DRY		LUBED		DRY	
	ft-lbs	Nm	ft-lbs	Nm	ft-lbs	Nm	ft-lbs	Nm	ft-lbs	Nm	ft-lbs	Nm	ft-lbs	Nm	ft-lbs	Nm
8	5.4	7.41	7.2	9.88	14	19.1	18.8	25.5	20.1	27.3	26.9	36.5	23.6	32	31.4	42.6
10	10.8	14.7	14.4	19.6	27.9	37.8	37.2	50.5	39.9	54.1	53.2	72.2	46.7	63.3	62.3	84.4
12	18.9	25.6	25.1	34.1	48.6	66	64.9	88	69.7	94.5	92.2	125	81	110	108	147
14	30.1	40.8	40	54.3	77.4	105	103	140	110	150	147	200	129	175	172	234
16	46.9	63.6	62.5	84.8	125	170	166	226	173	235	230	313	202	274	269	365
18	64.5	87.5	86.2	117	171	233	229	311	238	323	317	430	278	377	371	503
20	91	124	121	165	243	330	325	441	337	458	450	610	394	535	525	713
22	124	169	166	225	331	450	442	600	458	622	612	830	536	727	715	970
24	157	214	210	285	420	570	562	762	583	791	778	1055	682	925	909	1233



Scheduled Maintenance Procedures



Observe and Obey:

- ☑ Maintenance inspections shall be completed by a person trained and qualified on the maintenance of this machine.
- ☑ Scheduled maintenance inspections shall be completed daily, quarterly and semi-annually as specified on the *Maintenance Inspection Report*. The frequency and extent of periodical examinations and tests may also depend on national regulations.

⚠ WARNING Failure to properly complete each inspection when required may cause death, serious injury or substantial machine damage.

- ☑ Immediately tag and remove from service a damaged or malfunctioning machine.
- ☑ Repair any machine damage or malfunction before operating the machine.
- ☑ Use only Genie approved replacement parts.
- ☑ Machines that have been out of service for a period longer than 3 months must complete the quarterly inspection.
- ☑ Unless otherwise specified, perform each maintenance procedure with the machine in the following configuration:
 - Machine disconnected from tow vehicle
 - Machine parked on a firm, level surface
 - Boom in the stowed position with both latches secured
 - Key switch in the off position with the key removed
 - Wheels chocked
 - Parking brake applied

About This Section

This section contains detailed procedures for each scheduled maintenance inspection.

Each procedure includes a description, safety warnings and step-by-step instructions.

Symbols Legend



Safety alert symbol—used to alert personnel to potential personal injury hazards. Obey all safety messages that follow this symbol to avoid possible injury or death.



Indicates an imminently hazardous situation which, if not avoided, will result in death or serious injury.



Indicates a potentially hazardous situation which, if not avoided, could result in death or serious injury.



Indicates a potentially hazardous situation which, if not avoided, may cause minor or moderate injury.



Indicates a potentially hazardous situation which, if not avoided, may result in property damage.

⦿ Indicates that a specific result is expected after performing a series of steps.

⊗ Indicates that an incorrect result has occurred after performing a series of steps.

SCHEDULED MAINTENANCE PROCEDURES

Maintenance Symbols Legend

The following symbols have been used in this manual to help communicate the intent of the instructions. When one or more of the symbols appears at the beginning of a maintenance procedure, it conveys the meaning below.



Indicates that tools will be required to perform this procedure.



Indicates that new parts will be required to perform this procedure.



Indicates that a cold motor or pump will be required to perform this procedure.



Indicates that dealer service will be required to perform this procedure.

Pre-delivery Preparation Report

The pre-delivery preparation report contains checklists for each type of scheduled inspection.

Make copies of the *Pre-delivery Preparation* report to use for each inspection. Store completed forms as required.

Maintenance Schedule

There are five types of maintenance inspections that must be performed according to a schedule—daily, quarterly, semi-annually, annually, and two year. The *Scheduled Maintenance Procedures Section* and the *Maintenance Inspection Report* have been divided into five subsections—A, B, C, D, and E. Use the following chart to determine which group(s) of procedures are required to perform a scheduled inspection.

Inspection	Checklist
Daily or every 8 hours	A
Quarterly or every 250 hours or every 3000 miles / 5000 km	A + B
Semi-annually or every 500 hours or every 6000 miles / 10,000 km	A + B + C
Annually or every 1000 hours or every 12,000 miles	A + B + C + D
Two year or every 2000 hours	A + B + C + D + E

Maintenance Inspection Report

The maintenance inspection report contains checklists for each type of scheduled inspection.

Make copies of the *Maintenance Inspection Report* to use for each inspection. Maintain completed forms for a minimum of 4 years or in compliance with employer, jobsite and governmental regulations and requirements.

Pre-Delivery Preparation

Fundamentals

It is the responsibility of the dealer to perform the Pre-delivery Preparation.

The Pre-delivery Preparation is performed prior to each delivery. The inspection is designed to discover if anything is apparently wrong with a machine before it is put into service.

A damaged or modified machine must never be used. If damage or any variation from factory delivered condition is discovered, the machine must be tagged and removed from service.

Repairs to the machine may only be made by a qualified service technician, according to the manufacturer's specifications.

Scheduled maintenance inspections shall be performed by qualified service technicians, according to the manufacturer's specifications and the requirements listed in the responsibilities manual.

Instructions

Use the operator's manual on your machine.

The Pre-delivery Preparation consists of completing the Pre-operation Inspection, the Maintenance items and the Function Tests.

Use this form to record the results. Place a check in the appropriate box after each part is completed. Follow the instructions in the operator's manual.

If any inspection receives an N, remove the machine from service, repair and re-inspect it. After repair, place a check in the R box.

Legend

Y = yes, completed

N = no, unable to complete

R = repaired

Comments

Pre-Delivery Preparation	Y	N	R
Pre-operation inspection completed			
Maintenance items completed			
Function tests completed			

Model

Serial number

Date

Machine owner

Inspected by (print)

Inspector signature

Inspector title

Inspector company



Terex South Dakota, Inc USA
500 Oak Wood Road
PO Box 1150
Watertown, SD 57201-6150
(605) 882-4000

Genie UK
The Maltings, Wharf Road
Grantham, Lincolnshire
NG31-6BH England
(44) 1476-584333

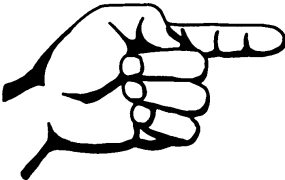

This page intentionally left blank.

Maintenance Inspection Report

Model
Serial number
Date
Hour meter
Machine owner
Inspected by (print)
Inspector signature
Inspector title
Inspector company

Instructions

- Make copies of this report to use for each inspection.
- Select the appropriate checklist(s) for the type of inspection to be performed.

<input type="checkbox"/>	Daily or 8 hours Inspection:	A
<input type="checkbox"/>	Quarterly or 250 hours or 3000 mile / 5000 km Inspection:	A+B
<input type="checkbox"/>	Semi-annually or 500 hours or 6000 mile / 10,000 km Inspection:	A+B+C
<input type="checkbox"/>	Annually or 1000 hours or 12,000 mile Inspection:	A+B+C+D
<input type="checkbox"/>	Two year or 2000 hours Inspection:	A+B+C+D+E

- Place a check in the appropriate box after each inspection procedure is completed.
- Use the step-by-step procedures in this section to learn how to perform these inspections.
- If any inspection receives an "N", tag and remove the machine from service, repair and re-inspect it. After repair, place a check in the "R" box.

Legend

Y = yes, acceptable
 N = no, remove from service
 R = repaired

Checklist A	Y	N	R
A-1 Manuals and Decals			
A-2 Pre-operation inspect			
A-3 Function tests			
A-4 Lug Bolts - ANSI/CSA/AS			
A-5 Lug Bolts - CE			
A-6 Hitch maintenance - ANSI/CSA/AS			

Perform after 40 hours:

A-7 Perform 30 day service			
----------------------------	--	--	--

Perform every 100 hours:

A-8 Grease rotate bearing			
---------------------------	--	--	--

Checklist B	Y	N	R
B-1 Batteries			
B-2 Electrical wiring			
B-3 Electrical Contactor			
B-4 Emergency Stop			
B-5 Key switch			
B-6 Manual override			
B-7 Platform rotation			
B-8 Hydraulic Oil Analysis			
B-9 Axle maintenance - ANSI/CSA/AS			
B-10 Wheel bearings - CE			
B-11 Hitch - CE			
B-12 Axle maintenance - CE			
B-13 Parking brake			
B-14 Tongue jack			

Checklist C	Y	N	R
C-1 Grease platform overload (if equipped)			
C-2 Test platform overload (if equipped)			
C-3 Axle maintenance - ANSI/CSA/AS			
C-4 Breather Cap			
C-5 Wheel Bearings - CE			
C-6 Brakes - CE			

Checklist D	Y	N	R
D-1 Axle maintenance - ANSI/CSA/AS			
D-2 Boom wear pads			
D-3 Hydraulic filter			
D-4 Turntable bearing bolts			
D-5 Turntable bearing wear			

Checklist E	Y	N	R
E-1 Hydraulic oil			

Comments

Checklist A Procedures

A-1

Inspect the Manuals and Decals

Genie specifications require that this procedure be performed daily or every 8 hours, whichever comes first.

Maintaining the operator's and safety manuals in good condition is essential to safe machine operation. Manuals are included with each machine and should be stored in the container provided in the platform. An illegible or missing manual will not provide safety and operational information necessary for a safe operating condition.

In addition, maintaining all of the safety and instructional decals in good condition is mandatory for safe machine operation. Decals alert operators and personnel to the many possible hazards associated with using this machine. They also provide users with operation and maintenance information. An illegible decal will fail to alert personnel of a procedure or hazard and could result in unsafe operating conditions.

- 1 Check to make sure that the operator's and safety manuals are present and complete in the storage container on the platform.
 - 2 Examine the pages of each manual to be sure that they are legible and in good condition.
- ⦿ Result: The operator's manual is appropriate for the machine and all manuals are legible and in good condition.
 - ✗ Result: The operator's manual is not appropriate for the machine or all manuals are not in good condition or are illegible. Remove the machine from service until the manual is replaced.

- 3 Open the operator's manual to the decals inspection section. Carefully and thoroughly inspect all decals on the machine for legibility and damage.
- ⦿ Result: The machine is equipped with all required decals, and all decals are legible and in good condition.
 - ✗ Result: The machine is not equipped with all required decals, or one or more decals are illegible or in poor condition. Remove the machine from service until the decals are replaced.
- 4 Always return the manuals to the storage container after use.

Note: Contact your authorized Genie distributor or Genie if replacement manuals or decals are needed.

CHECKLIST A PROCEDURES

A-2 Perform Pre-operation Inspection

Completing a Pre-operation Inspection is essential to safe machine operation. The Pre-operation Inspection is a visual inspection performed by the operator prior to each work shift. The inspection is designed to discover if anything is apparently wrong with a machine before the operator performs the function tests. The Pre-operation Inspection also serves to determine if routine maintenance procedures are required.

Complete information to perform this procedure is available in the appropriate operator's manual. Refer to the Operator's Manual on your machine.

A-3 Perform Function Tests

Completing the function tests is essential to safe machine operation. Function tests are designed to discover any malfunctions before the machine is put into service. A malfunctioning machine must never be used. If malfunctions are discovered, the machine must be tagged and removed from service.

Complete information to perform this procedure is available in the appropriate operator's manual. Refer to the Operator's Manual on your machine.

A-4 Torque the Lug Bolts - ANSI/CSA/AS



Axle specifications require that this procedure be performed initially after 10, 25 and 50 miles.

Proper axle maintenance, following the axle manufacturer's maintenance schedule, is essential to good axle performance and service life. Failure to perform the maintenance procedures can lead to poor axle performance and component damage.

- 1 Check each lug bolt for proper torque. Refer to Section 2, *Specifications*.

Required maintenance procedures and additional axle information is available in the *Dexter Axle Operation Maintenance Service Manual* (Dexter part number LIT-001-00).

Dexter Axle Operation Maintenance Service Manual	
Genie part number	84376

CHECKLIST A PROCEDURES

A-5 Torque the Lug Bolts - CE



Axle specifications require that this procedure be performed initially after 50 km, or 50 km after a wheel change.

Proper axle maintenance, following the axle manufacturer's maintenance schedule, is essential to good axle performance and service life. Failure to perform the maintenance procedures can lead to poor axle performance and component damage.

- 1 Check each lug bolt for proper torque. Refer to Section 2, *Specifications*.

Required maintenance procedures and additional axle information is available in the *KNOTT Axle Service Manual* (KNOTT part number P005).

KNOTT Axle Service Manual

Genie part number 84443

A-6 Perform Hitch Maintenance - ANSI/CSA/AS



Hitch specifications require that this procedure be performed weekly.

- Brake fluid level
- Inspect actuator

Required maintenance procedures and additional hitch information is available in the *Demco Model 91 Brake Actuators Owner/Operator Manual* (Demco part number BH20023).

Demco Model 91 Owner/Operator Manual

Genie part number 84592

CHECKLIST A PROCEDURES

A-7 Perform 30 Day Service



The 30 day maintenance procedure is a onetime procedure to be performed after the first 30 days or 40 hours of usage. After this interval, refer to the maintenance tables for continued scheduled maintenance.

1 Perform the following maintenance procedures:

- A-8 Grease the Turntable Rotation Bearing and Rotate Gear
- B-13 Inspect the Parking Brake
- D-3 Replace the Hydraulic Tank Return Filter
- D-4 Check the Turnable Rotation Bearing Bolts

A-8 Grease the Turntable Rotation Bearing and Rotate Gear



Genie specifications require that this procedure be performed every 100 hours of operation.

Regular application of lubrication to the turntable bearing and rotate gear is essential to good machine performance and service life. Continued use of an insufficiently greased bearing and gear will result in component damage.

- 1 Raise the boom enough to access the turntable bearing.
- 2 Locate the grease fitting on the platform end of the turntable, next to the boom hold-down latch.
- 3 Pump multipurpose grease into the turntable rotation bearing. Rotate the turntable in increments of 4 to 5 inches / 10 to 13 cm at a time and repeat this step until the entire bearing has been greased.
- 4 Apply grease to each tooth of the drive gear located under the turntable.

Grease type	Multipurpose grease
--------------------	---------------------

Checklist B Procedures

B-1 Inspect the Batteries



Proper battery condition is essential to good machine performance and operational safety. A faulty battery cell can result in poor machine performance and improper fluid levels or damaged cables and connections can result in component damage and hazardous conditions.

⚠ WARNING Bodily injury hazard. Batteries contain acid. Avoid spilling or contacting battery acid. Neutralize battery acid spills with baking soda and water.

⚠ WARNING Electrocutation hazard. Contact with hot or live circuits could result in death or serious injury. Remove all rings, watches and other jewelry.

NOTICE Perform this test after fully charging the battery.

NOTICE For a more accurate determination of battery condition, fully charge the batteries and allow the batteries to rest 24 hours before performing this procedure to allow the battery cells to equalize.

- 1 Put on protective clothing and eye wear.
- 2 Be sure that the battery cable connections are free of corrosion.

- 3 Be sure that the battery retaining fasteners and cable connections are tight.
- 4 Remove the battery vent caps from all batteries and check the specific gravity of each battery cell with a hydrometer.
- ⑤ **Result:** If any battery cell displays a specific gravity of less than 1.026, the battery must be replaced.
- 5 Check the battery acid level of each battery. If needed, replenish with distilled water to the bottom of each battery fill tube. Do not overfill.
- 6 Install the battery vent caps.
- 7 Check each battery pack and verify that the batteries are wired correctly.

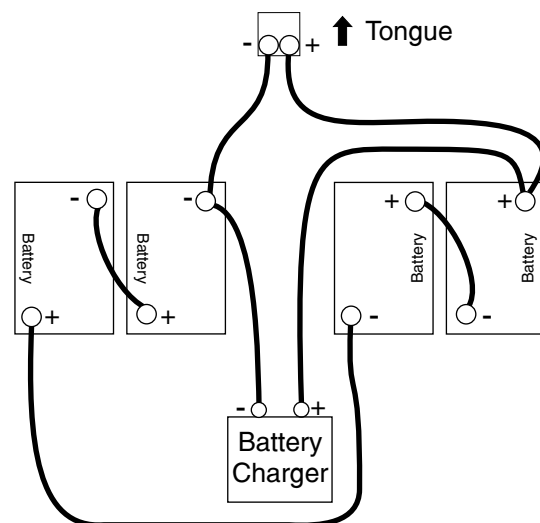

CHECKLIST B PROCEDURES

B-2 Inspect the Electrical Wiring

Maintaining electrical wiring in good condition is essential to safe operation and good machine performance. Failure to find and replace burnt, chafed, corroded or pinched wires could result in unsafe operating conditions and may cause component damage.

⚠ WARNING Electrocutation hazard. Contact with hot or live circuits could result in death or serious injury. Remove all rings, watches and other jewelry.

- 1 Inspect the following areas for burnt, chafed, corroded and loose wires:
 - Turntable area
 - Ground controls
 - Power unit wiring
- 2 Turn the key switch to ground control and pull out the red Emergency Stop button to the on position at both the ground and platform controls.
- 3 Raise the secondary boom until the platform is approximately 10 feet / 3 m off the ground.
- 4 Inspect the boom storage area for burnt, chafed and pinched cables.
- 5 Lower the boom to the stowed position and turn the machine off.
- 6 Inspect the following areas for burnt, chafed, corroded, pinched and loose wires:
 - Boom to platform cable harness
 - Primary and secondary booms

B-3 Inspect the Electrical Contactor



Genie requires that this procedure be performed every 250 hours or quarterly, whichever comes first.

Maintaining the electrical contactor in good condition is essential to safe machine operation. Failure to locate a worn or damaged contactor could result in an unsafe working condition and component damage.

- 1 At the ground controls, turn the key switch to the off position and push in the red Emergency Stop button to the off position.
- 2 Disconnect the batteries.
- 3 Remove the hydraulic power unit cover.
- 4 Locate the electrical contactor mounted by the hydraulic power unit.
- 5 Visually inspect the contact points of the contactor for the following items:
 - Excessive burns
 - Excessive arcs
 - Excessive pitting

⚠ WARNING Electrocutation/burn hazard. Contact with hot or live circuits could result in death or serious injury. Remove all rings, watches and other jewelry.

Note: Replace the contactor if any damage is found.

CHECKLIST B PROCEDURES

B-4 Test the Emergency Stop

A properly functioning Emergency Stop is essential for safe machine operation. An improperly operating red Emergency Stop button will fail to shut off power and stop all machine functions, resulting in a hazardous situation.

Note: As a safety feature, selecting and operating the ground controls will override the platform controls.

- 1 Turn the key switch to ground control and pull out the red Emergency Stop button to the on position at both the ground and platform controls.
 - 2 Push in the red Emergency Stop button at the ground controls to the off position.
- ⊙ Result: No machine functions should operate.
- 3 Turn the key switch to platform control and pull out the red Emergency Stop button to the on position at both the ground and platform controls.
 - 4 Push in the red Emergency Stop button at the platform controls to the off position.

⊙ Result: No machine functions should operate.

Note: The red Emergency Stop button at the ground controls will stop all machine operation without regard to the position of the key switch.

B-5 Test the Key Switch

Proper key switch action and response is essential to safe machine operation. The machine can be operated from the ground or platform controls and the activation of one or the other is accomplished with the key switch. Failure of the key switch to activate the appropriate control panel could cause a hazardous operating situation.

Note: Perform this procedure from the ground using the platform controls. Do not stand in the platform.

- 1 Pull out the red Emergency Stop button to the on position at both the ground and platform controls.
 - 2 Turn the key switch to **platform control**.
 - 3 Check the platform up/down function from the **ground controls**.
- ⊙ Result: The machine functions should **not** operate.
- 4 Turn the key switch to **ground control**.
 - 5 Check the machine functions from the **platform controls**.
- ⊙ Result: The machine functions should **not** operate.
- 6 Turn the key switch to the off position.
- ⊙ Result: No function should operate.

CHECKLIST B PROCEDURES

B-6 Test the Manual Override

Testing the manual override for malfunctions is essential for safe machine operation. An unsafe working condition exists if the manual override function does not operate in the event of a main power loss.

Before serial number TZ3405-172:

- 1 Locate the primary boom up valve at the side of the manifold opposite the ground controls. Fully loosen the thumbscrew locknut and turn the thumbscrew fully in a clockwise direction to open the valve.
- Result: The locknut should loosen and the thumbscrew should screw all the way in.

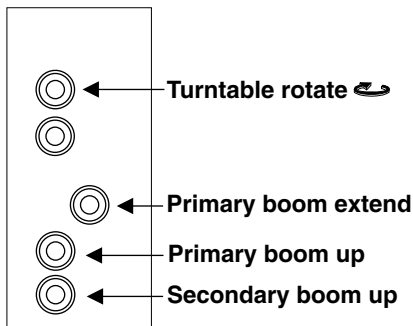

Turntable rotate side

- 2 To close the valve, turn the thumbscrew fully in a counterclockwise direction. Tighten the locknut.

Note: The machine functions will not operate unless the valves are closed.

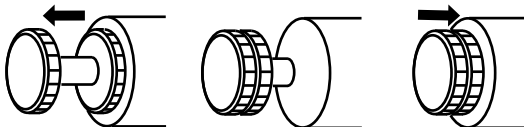

- 3 Locate the secondary boom up valve at the side of the manifold opposite the ground controls. Fully loosen the thumbscrew locknut and turn the thumbscrew fully in a clockwise direction to open the valve.
- Result: The locknut should loosen and the thumbscrew should screw all the way in.
- 4 To close the valve, turn the thumbscrew fully in a counterclockwise direction. Tighten the locknut.

Note: The machine functions will not operate unless the valves are closed.

- 5 Locate the primary boom extend valve at the side of the manifold opposite the ground controls. Fully loosen the thumbscrew locknut and turn the thumbscrew fully in a clockwise direction to open the valve.
- Result: The locknut should loosen and the thumbscrew should screw all the way in.
- 6 To close the valve, turn the thumbscrew fully in a counterclockwise direction. Tighten the locknut.

Note: The machine functions will not operate unless the valves are closed.

- 7 Locate the primary boom down valve on the manifold at the ground controls side of the machine. Fully loosen the thumbscrew locknut and turn the thumbscrew fully in a clockwise direction to open the valve.
- Result: The locknut should loosen and the thumbscrew should screw all the way in.

CHECKLIST B PROCEDURES

- 8 Turn the thumbscrew fully in a counterclockwise direction to close the valve. Tighten the locknut.

Note: The machine functions will not operate unless the valves are closed.

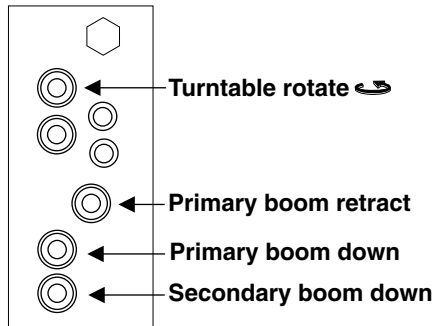

Ground controls side

- 9 Locate the secondary boom down valve on the manifold at the ground controls side of the machine. Fully loosen the thumbscrew locknut and turn the thumbscrew fully in a clockwise direction to open the valve.

⊙ Result: The locknut should loosen and the thumbscrew should screw all the way in.

- 10 Turn the thumbscrew fully in a counterclockwise direction to close the valve. Tighten the locknut.

Note: The machine functions will not operate unless the valves are closed.

- 11 Locate the primary boom retract valve on the manifold at the ground controls side of the machine. Loosen the thumbscrew locknut and turn the thumbscrew fully in a counterclockwise direction to open the valve.

⊙ Result: The locknut should loosen and the thumbscrew should screw all the way in.

- 12 Turn the thumbscrew fully in a counterclockwise direction to close the valve. Tighten the locknut.

Note: The machine functions will not operate unless the valves are closed.

- 13 Locate the turntable rotate valve on the manifold at the ground controls side of the machine. Fully loosen the thumbscrew locknut and turn the thumbscrew fully in a clockwise direction to open the valve. Push the turntable in either direction.

⊙ Result: The locknut should loosen, the thumbscrew should screw all the way in and the turntable should rotate.

- 14 Turn the thumbscrew fully in a counterclockwise direction to close the valve. Tighten the locknut.

Note: The machine functions will not operate unless the valves are closed.

CHECKLIST B PROCEDURES

From serial number TZ3403-249 to TZ3405-171:

15 Locate the turntable rotate valve at the side of the manifold opposite the ground controls. Fully loosen the thumbscrew locknut and turn the thumbscrew fully in a clockwise direction to open the valve.

- ⦿ Result: The locknut should loosen and the thumbscrew should screw all the way in.

16 Turn the thumbscrew fully in a counterclockwise direction to close the valve. Tighten the locknut.

Note: The machine functions will not operate unless the valves are closed.

17 Locate the turntable rotate function valve coil on the manifold at the ground controls side of the machine. Loosen the thumbscrew locknut and turn the thumbscrew fully in a clockwise direction to open the valve.

- ⦿ Result: The locknut should loosen and the thumbscrew should screw all the way in.

18 Turn the thumbscrew fully in a counterclockwise direction to close the valve. Tighten the locknut.

Note: The machine functions will not operate unless the valves are closed.

After serial number TZ3405-171:

1 Locate the primary boom up/down valve at the manifold on the ground controls side of the machine. Push the thumbscrew in and turn fully in a clockwise direction to open the valve.

- ⦿ Result: The thumbscrew should move easily.

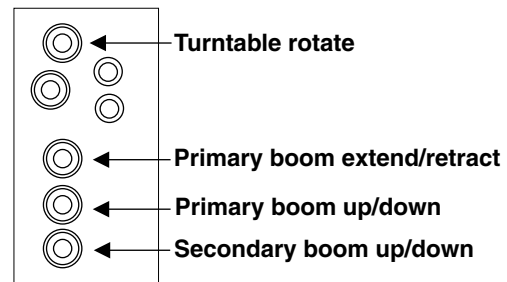

Ground controls side

2 To close the valve, push the thumbscrew in and turn fully in a counterclockwise direction and release.

3 Pull the thumbscrew out and turn fully in a clockwise direction to open the valve.

- ⦿ Result: The thumbscrew should move easily.

4 To close the valve, pull the thumbscrew out and turn fully in a clockwise direction and release.

Note: The machine functions will not operate unless the valves are closed.

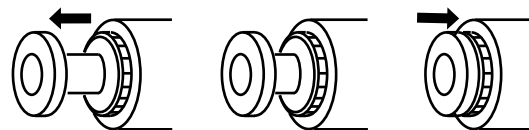

CHECKLIST B PROCEDURES

5 Locate the secondary boom up/down valve at the manifold. Push the thumbscrew in and turn fully in a clockwise direction to open the valve.

⦿ Result: The thumbscrew should move easily.

6 To close the valve, push the thumbscrew in and turn fully in a counterclockwise direction and release.

7 Pull the thumbscrew out and turn fully in a clockwise direction to open the valve.

⦿ Result: The thumbscrew should move easily.

8 To close the valve, pull the thumbscrew out and turn fully in a counterclockwise direction and release.

Note: The machine functions will not operate unless the valves are closed.

9 Locate the primary boom extend/retract valve at the manifold. Push the thumbscrew in and turn fully in a clockwise direction to open the valve.

⦿ Result: The thumbscrew should move easily.

10 To close the valve, push the thumbscrew in and turn fully in a counterclockwise direction and release.

11 Pull the thumbscrew out and turn fully in a clockwise direction to open the valve.

⦿ Result: The thumbscrew should move easily.

12 To close the valve, pull the thumbscrew out and turn fully in a counterclockwise direction and release.

Note: The machine functions will not operate unless the valves are closed.

13 Locate the turntable rotate valve at the manifold. Push the thumbscrew in and turn fully in a clockwise direction to open the valve.

⦿ Result: The thumbscrew should move easily.

14 To close the valve, push the thumbscrew in and turn fully in a counterclockwise direction and release.

15 Pull the thumbscrew out and turn fully in a clockwise direction to open the valve.

⦿ Result: The thumbscrew should move easily.

16 To close the valve, pull the thumbscrew out and turn fully in a counterclockwise direction and release.

Note: The machine functions will not operate unless the valves are closed.

CHECKLIST B PROCEDURES

B-7 Test the Platform Rotation (if equipped)

Testing the platform rotation for malfunctions is essential for safe machine operation. The platform rotator is operated by manually turning the hand crank in either a clockwise or counterclockwise direction.

- 1 Turn the hand crank at the platform in the clockwise direction.
 - ⦿ Result: The platform should rotate to the right and operate smoothly without any hesitation or binding.
- 2 Turn the hand crank at the platform in the counterclockwise direction.
 - ⦿ Result: The platform should rotate to the left and operate smoothly without any hesitation or binding.

B-8 Perform Hydraulic Oil Analysis



Replacement or testing of the hydraulic oil is essential for good machine performance and service life. Dirty oil may cause the machine to perform poorly and continued use may cause component damage. Extremely dirty conditions may require oil changes to be performed more often.

Note: Before replacing the hydraulic oil, the oil may be tested by an oil distributor for specific levels of contamination to verify that changing the oil is necessary. **If the hydraulic oil is not replaced at the two year inspection, test the oil quarterly. Replace the oil when it fails the test.** See E-1, *Test or Replace the Hydraulic Oil*.

CHECKLIST B PROCEDURES

B-9 Perform Axle Maintenance - ANSI/CSA/AS



Axle specifications require that this procedure be performed quarterly or every 3000 miles, whichever comes first.

- Brake Adjustment

Required maintenance procedures and additional axle information is available in the *Dexter Axle Operation Maintenance Service Manual* (Dexter part number LIT-001-00).

Dexter Axle Operation Maintenance Service Manual
Genie part number 84376

B-10 Check the Wheel Bearings - CE



Axle specifications require that this procedure be performed quarterly or every 5000 km, whichever comes first.

Proper axle maintenance, following the axle manufacturer's maintenance schedule, is essential to good axle performance and service life. Failure to perform the maintenance procedures can lead to poor axle performance and component damage.

- 1 At the ground controls, extend the outriggers until the axle is off the ground and the machine is level.
- 2 Check for wheel bearing wear by attempting to move the wheel hub side to side, then up and down.
 - ⦿ Result: There should be no side to side or up and down movement.
 - ✗ Result: There is side to side or up and down movement. See C-5, Grease the Axle Wheel Bearings - CE.

Required maintenance procedures and additional axle information is available in the *KNOTT Axle Service Manual* (KNOTT part number P005).

KNOTT Axle Service Manual
Genie part number 84443

CHECKLIST B PROCEDURES

B-11**Service the Hitch - CE**

Axle specifications require that this procedure be performed quarterly or every 5000 km, whichever comes first.

Proper axle maintenance, following the axle manufacturer's maintenance schedule, is essential to good axle performance and service life. Failure to perform the maintenance procedures can lead to poor axle performance and component damage.

- 1 Clean all visible surfaces of the ball coupler.
- 2 Lubricate the hitch at both grease fittings at the top of the over-run hitch.
- 3 Lubricate all bolts and articulated points on the hand brake lever using commonly available machine oil or motor oil.
- 4 Lubricate all bolts and movable parts of the coupler using commonly available machine oil or motor oil.
- 5 Lightly grease the ball mount.
- 6 Confirm that the brake cable is securely installed into the brake handle linkage.
- 7 Apply the hand brake.

- 8 Attempt to manually push the machine.

- ⊙ Result: The machine does not move.
- ⊙ Result: The machine moves. Adjust the brakes. See Maintenance procedure C-6, *Adjust the Brakes - CE*.

Required maintenance procedures and additional axle information is available in the *KNOTT Axle Service Manual* (KNOTT part number P005).

KNOTT Axle Service Manual

Genie part number

84443

B-12**Perform Axle Maintenance - CE**

Axle specifications require that this procedure be performed annually or every 5000 km, whichever comes first.

- Brake Inspection
- Axle Inspection

Required maintenance procedures and additional axle information is available in the *KNOTT Axle Service Manual* (KNOTT part number P005).

KNOTT Axle Service Manual

Genie part number

84443

CHECKLIST B PROCEDURES

B-13 Inspect the Parking Brake



A properly functioning parking brake is essential to safe machine operation. The parking brake is manually activated. An improperly functioning parking brake will prevent the operator from properly securing the machine when not in use.

- 1 Visually inspect the parking brake cables and components for damage.
- 2 Visually inspect the parking brake cables to ensure both are properly secured and installed into the brake backing plate.
- 3 Set the parking brake.

Note: If the brake cables are too tight the parking brake will be difficult to set. If the brake cables are too loose, the brakes will not activate when the lever is set.

- 4 Attempt to manually push the machine.

⦿ Result: The machine should not move.

✗ Result: The machine moves. Refer to Repair procedure 9-2, *How To Adjust the Parking Brake*.

B-14 Service the Tongue Jack



Maintaining the tongue jack in good condition is essential to safe operation and good machine performance. Failure to lubricate the internal gears and bearings of the jack and axle bolt could result in unsafe operating conditions and may cause component damage.

- 1 Using a needle nose applicator, pump a small amount of automotive grease through the lubrication opening. Rotate the handle to evenly distribute the lubricant to the internal gears.

Note: The lubrication opening is located on the side of the jack, above the support plate.

- 2 Lightly grease the inner tube of the jack with the same type of grease.
- 3 Lubricate the handle at both sides of the tube with a lightweight oil.
- 4 Lubricate the axle bolt and nut assembly with a lightweight oil.

ANSI models:

- 5 Check each tire with an air pressure gauge and add air as needed. Refer to Section 2, *Specifications*.

⚠ WARNING An over-inflated tire can explode and could result in death or serious injury.

Checklist C Procedures

C-1

Grease the Platform Overload Mechanism (if equipped)



Genie specifications require that this procedure be performed every 500 hours or 6 months, whichever comes first. Perform this procedure more often if dusty conditions exist.

Application of lubrication to the platform overload mechanism is essential to safe machine operation. Continued use of an improperly greased platform overload mechanism could result in the system not sensing an overloaded platform condition and will result in component damage.

- 1 Locate the grease fittings on each pivot pin of the platform overload assembly.
- 2 Thoroughly pump grease into each grease fitting using a multi-purpose grease.

C-2

Test the Platform Overload System (if equipped)



Genie specifications require that this procedure be performed every 500 hours or 6 months, whichever comes first.

Testing the platform overload system regularly is essential to safe machine operation. Continued use of an improperly operating platform overload system could result in the system not sensing an overloaded platform condition. Machine stability could be compromised resulting in the machine tipping over.

Note: Perform this procedure with the machine on a firm, level surface.

- 1 At the ground controls, extend the outriggers until the tires are off the ground and the machine is level.
 - 2 Release the boom hold down latch.
 - 3 Turn the key switch to platform control.
 - 4 Level the platform.
 - 5 Determine the maximum platform capacity. Refer to the machine serial plate.
 - 6 Using a suitable lifting device, place an appropriate test weight equal to the maximum platform capacity in the center of the platform floor.
- ⦿ Result: The platform overload indicator light should be off at both the ground and platform controls.

CHECKLIST C PROCEDURES

7 Add an additional 44 lbs / 20 kg of weight to overload the platform.

⦿ Result: The platform overload indicator light should be flashing at both the ground and platform controls.

8 Test all machine functions from the platform controls.

⦿ Result: All platform control functions should not operate.

9 Turn the key switch to ground control.

10 Test all machine functions from the ground controls.

⦿ Result: All ground control functions should not operate.

11 Lift the test weight off the platform floor using a suitable lifting device.

⦿ Result: The platform overload indicator light should turn off at both the ground and platform controls.

12 Test all machine functions from the ground controls.

⦿ Result: All ground control functions should operate normally.

13 Turn the key switch to platform control.

14 Test all machine functions from the platform controls.

⦿ Result: All platform control functions should operate.

Note: If the platform overload system is not operating properly, refer to Repair Procedure 11-1, *Calibrate the Platform Overload System (if equipped)*.

CHECKLIST C PROCEDURES

C-3 Perform Axle Maintenance - ANSI/CSA/AS



Axle specifications require that this procedure be performed every 6 months or 6000 miles, whichever comes first.

- Brake Magnets
- Brake Controller
- Suspension Components

Required maintenance procedures and additional axle information is available in the *Dexter Axle Operation Maintenance Service Manual* (Dexter part number LIT-001-00).

Dexter Axle Operation Maintenance Service Manual
Genie part number 84376

C-4 Replace the Hydraulic Tank Breather Cap - Models with Optional Hydraulic Oil



The hydraulic tank is a vented-type tank. The breather cap has an internal air filter that can become clogged or, over time, can deteriorate. If the breather cap is faulty or improperly installed, impurities can enter the hydraulic system which may cause component damage. Extremely dirty conditions may require that the cap be inspected more often.

- 1 Remove and discard the hydraulic tank breather cap.
- 2 Install a new cap onto the tank.

CHECKLIST C PROCEDURES

C-5 Grease the Axle Wheel Bearings CE



Axle specifications require that this procedure be performed every 6 months or 10,000 km, whichever comes first.

Maintaining the axle wheel bearings is essential to safe operation and good machine performance. Towing the machine with loose or worn wheel bearings may cause an unsafe towing condition and continued use may result in component or property damage. Regular steam cleaning and pressure washing of the machine may require that this procedure be performed more often.

- 1 Loosen the wheel lug bolts. Do not remove them.
- 2 At the ground controls, extend the outriggers until the axle is off the ground and the machine is level.
- 3 Remove the lug bolts and remove the tire and wheel assembly from the machine.
- 4 Remove, wash and inspect the axle wheel bearings and spacer ring.
- 5 Pack both bearings with clean, fresh grease.
- 6 Install the bearings and spacer ring onto the axle and reassemble the axle.
- 7 Tighten the castle nut until the wheel runs with a little bite.

- 8 Loosen the castle nut just until the cotter pin fits into the next hole. Install a new cotter pin and lock into position. Install the dust cap.

NOTICE Always replace the cotter pin with a new one when removing the castle nut or when checking the torque of the castle nut.

- 9 Install the tire and wheel onto the axle. Install and torque the lug bolts to specification. Refer to Section 2, *Specifications*.
- 10 Perform steps 3 through 9 for the other side of the machine.
- 11 Return the outriggers to the stowed position.

Required maintenance procedures and additional axle information is available in the *KNOTT Axle Service Manual* (KNOTT part number P005).

KNOTT Axle Service Manual

Genie part number

84443

CHECKLIST C PROCEDURES

C-6**Adjust the Brakes - CE**

Axle specifications require that this procedure be performed every 6 months or 10,000 km, whichever comes first.

Proper axle maintenance, following the axle manufacturer's maintenance schedule, is essential to good axle performance and service life. Failure to perform the maintenance procedures can lead to poor axle performance and component damage.

- 1 At the ground controls, extend the outriggers until the axle is off the ground and the machine is level.
- 2 Release the parking brake.
- 3 Working from the exposed inside face of the brake plate, opposite the cable entry, tighten the adjusting screw until the wheel can only be turned with difficulty or not at all.

NOTICE When tighten the adjusting screw, turn the wheel only in the direction of travel.

- 4 Ease off the adjusting screw approximately one-half turn in a counterclockwise direction, until the wheel turns freely.
- 5 Repeat steps 3 through 4 for the other brake.

- 6 Inspect the balance plate at the control cables.
 - ⦿ Result: The balance plate is at a right angle to the direction of towing.
 - ✗ Result: The balance plate is not at a right angle to the direction of towing. Tighten or loosen the brake cable ends coming from the axle until the balance plate is at a right angle to the direction of towing.
- 7 Return the outriggers to the stowed position.
- 8 Apply the parking brake.
- 9 Attempt to manually push the machine.
 - ⦿ Result: The machine does not move.
 - ✗ Result: The machine moves. Repeat this procedure beginning with step 1.
 - ✗ Result: One wheel rolls and the other one doesn't. Repeat step 6 and adjust the balance plate to tighten the brake cable from the wheel which is rolling.

Required maintenance procedures and additional axle information is available in the *KNOTT Axle Service Manual* (KNOTT part number P005).

KNOTT Axle Service Manual

Genie part number

84443

Checklist D Procedures

D-1

Perform Axle Maintenance - ANSI/CSA/AS



Axle specifications require that this procedure be performed every 12 months or 12,000 miles, whichever comes first.

- Brake lining
- Brake cylinders
- Brake lines
- Trailer brake wiring
- Hub/Drum
- Wheel bearings
- Seals
- Springs
- Hangers

Required maintenance procedures and additional axle information is available in the *Dexter Axle Operation Maintenance Service Manual* (Dexter part number LIT-001-00).

Dexter Axle Operation Maintenance Service Manual
Genie part number 84376

D-2

Check the Boom Wear Pads



Maintaining the boom wear pads in good condition is essential to safe machine operation. Wear pads are placed on boom tube surfaces to provide a low friction, replaceable wear pad between moving parts. Improperly shimmed wear pads or continued use of extremely worn wear pads may result in component damage and unsafe operating conditions.

Note: If the wear pads are within specification, refer to Repair Procedure 3-2, *How to Shim the Boom*.

- 1 Extend the boom until the wear pads are accessible.
- 2 Measure the thickness of the top, side and bottom wear pads. If the wear pad is within specification, shim as necessary to obtain zero clearance and zero drag.
- 3 Extend and retract the boom through the entire range of motion to check for tight spots that may cause binding or scraping of the boom.

Note: Always maintain squareness between the outer and inner boom tubes.

Boom wear pad specifications

Wear pad thickness, minimum	7/16 inch 11 mm
-----------------------------	--------------------

CHECKLIST D PROCEDURES

D-3 Replace the Hydraulic Tank Return Filter



Replacement of the hydraulic tank return filter element is essential for good machine performance and service life. A dirty or clogged filter element may cause the machine to perform poorly and continued use may cause component damage. Extremely dirty conditions may require that the filter element be replaced more often.

CAUTION Burn hazard. Beware of hot oil. Contact with hot oil may cause severe burns.

- 1 Clean the area around the hydraulic oil filter. Remove the filter with an oil filter wrench.

WARNING Bodily injury hazard. Spraying hydraulic oil can penetrate and burn skin. Loosen hydraulic connections very slowly to allow the oil pressure to dissipate gradually. Do not allow oil to squirt or spray.

- 2 Use a permanent ink marker to write the date and number of hours from the hour meter on the new filter.
- 3 Apply a thin layer of fresh oil onto the gasket of the new oil filter.

- 4 Install the filter and tighten it securely by hand.

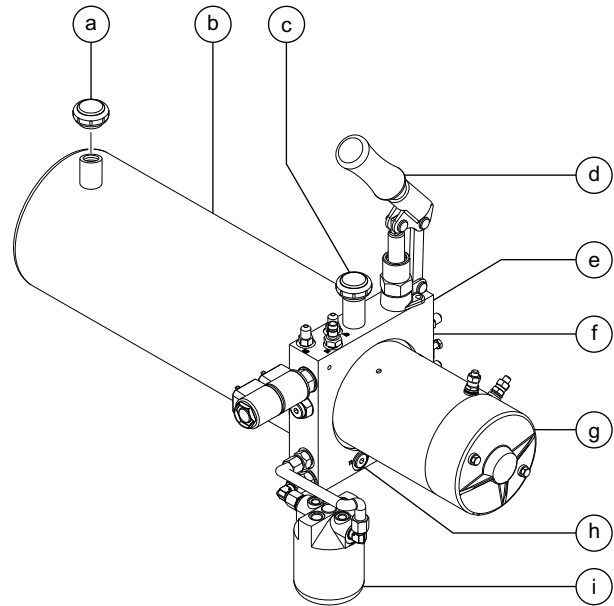

Power unit components

- a breather cap
- b hydraulic tank
- c filler cap
- d hand pump
- e sight gauge (hidden from view)
- f hydraulic pump
- g motor
- h drain plug
- i hydraulic filter

- 5 Clean up any oil that may have spilled during the replacement procedure. Properly discard the used filter.

CHECKLIST D PROCEDURES

- 6 Turn the key switch to ground controls and pull out the red Emergency Stop button to the on position at both the ground and platform controls.
- 7 Press and hold the yellow function enable button and activate the outrigger autolevel function.
- ① Result: The motor should activate and the outriggers should lower.
- 8 Inspect the filter and related components to be sure that there are no leaks.

D-4 Check the Turntable Rotation Bearing Bolts



Maintaining proper torque on the turntable bearing bolts is essential to safe machine operation. Improper bolt torque or torque sequence could result in an unsafe operating condition and component damage.

- 1 Be sure that each turntable rotation bearing mounting bolt above the turntable is torqued in sequence to specification. See below.

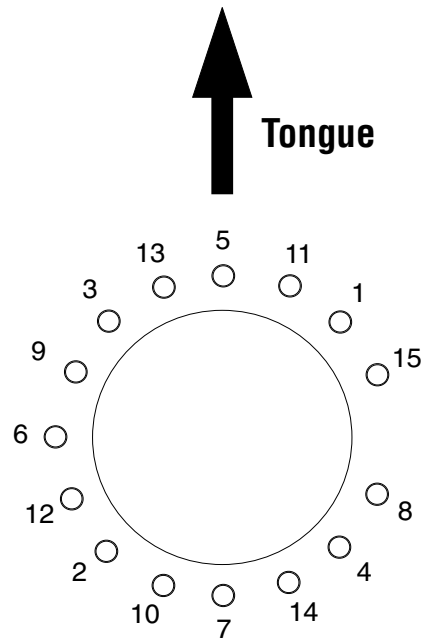

Bearing-to-turntable bolt torque sequence

CHECKLIST D PROCEDURES

- Working through the bearing bolt access, be sure that each turntable rotation bearing mounting bolt is torqued in sequence to specification. See below.

Note: The rotate bearing bolt access is located next to the turntable rotate motor.

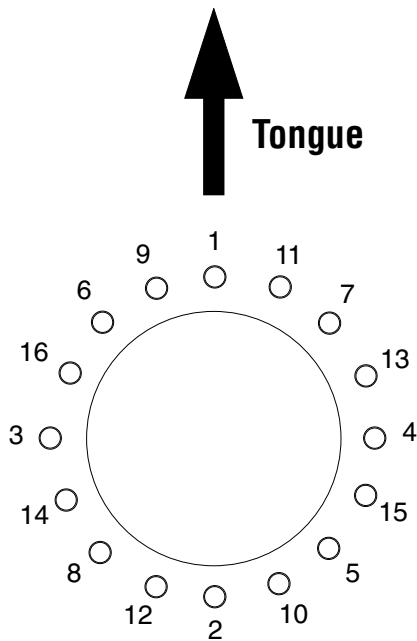

Bearing-to-chassis bolt torque sequence

Turntable rotation bearing bolt torque specifications

Bearing to chassis, lubricated	95 ft-lbs 129 Nm
Bearing to turntable, lubricated	200 ft-lbs 271 Nm

**D-5
Inspect for
Turntable Bearing Wear**



Periodic inspection of turntable bearing wear is essential to safe machine operation, good machine performance and service life. Continued use of a worn turntable bearing could create an unsafe operating condition, resulting in death or serious injury and component damage.

NOTICE Perform this procedure with the machine on a firm, level surface and the boom in the stowed position.

- Grease the turntable bearing. See A-8, *Grease the Turntable Rotation Bearing and Rotate Gear*.
- Torque the turntable bearing bolts to specification. See D-4, *Check the Turntable Rotation Bearing Bolts*.
- Start the machine from the ground controls and raise the primary and secondary booms to full height. Do not extend the primary boom.
- Place a dial indicator between the drive chassis and the turntable at a point that is directly under, or inline with, the boom and no more than 1 inch / 2.5 cm from the bearing.

Note: To obtain an accurate measurement, place the dial indicator no more than 1 inch / 2.5 cm from the turntable rotation bearing.

CHECKLIST D PROCEDURES

- 5 At the dial indicator, adjust it to "zero" the indicator.

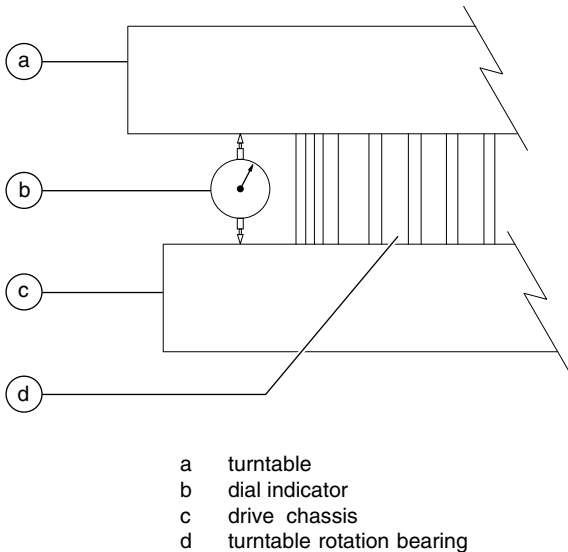

- 6 Lower the secondary boom to the stowed position and lower the primary boom to a horizontal position. Fully extend the primary boom.
- 7 Note the reading on the dial indicator.
- ⊙ Result: The measurement is less than 0.025 inch / 0.635 mm. The bearing is good.
- ⊗ Result: The measurement is more than 0.025 inch / 0.635 mm. The bearing is worn and needs to be replaced.
- 8 Fully retract the primary boom. Raise the primary and secondary booms to full height. Visually inspect the dial indicator to be sure the needle returns to the "zero" position.
- 9 Remove the dial indicator and rotate the turntable 90°.
- 10 Repeat steps 4 through 9 until the rotation bearing has been checked in at least four equally spaced areas 90° apart.
- 11 Lower the primary and secondary booms to the stowed position and turn the machine off.
- 12 Remove the dial indicator from the machine.

Checklist E Procedure

E-1 Test or Replace the Hydraulic Oil



Replacement or testing of the hydraulic oil is essential for good machine performance and service life. Dirty oil and suction strainers may cause the machine to perform poorly and continued use may cause component damage. Extremely dirty conditions may require oil changes to be performed more often.

Note: Before replacing the hydraulic oil, the oil may be tested by an oil distributor for specific levels of contamination to verify that changing the oil is necessary. **If the hydraulic oil is not replaced at the two year inspection, test the oil quarterly. Replace the oil when it fails the test.**

Note: Perform this procedure with the boom in the stowed position.

- 1 Open the power unit module tray.
- 2 Disconnect the battery pack from the machine.

⚠ WARNING Electrocutation hazard. Contact with hot or live circuits could result in death or serious injury. Remove all rings, watches and other jewelry.

- 3 Remove the drain plug from the power unit valve body and completely drain the tank into a suitable container. Refer to Section 2, *Specifications*, for capacity information.

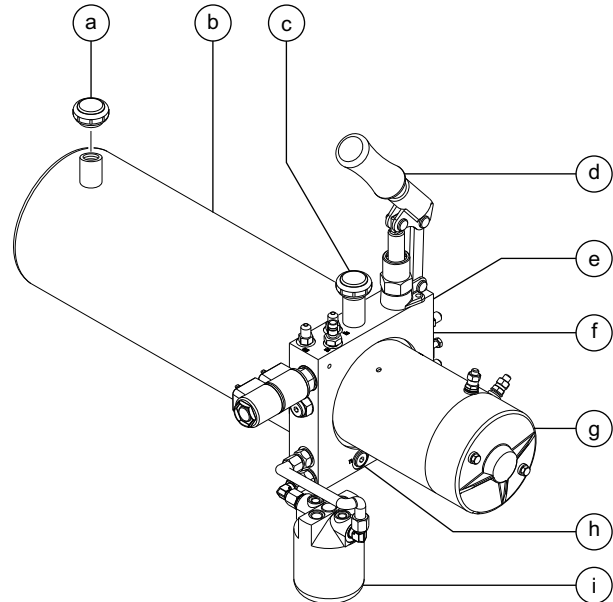

Power unit components

- a breather cap
- b hydraulic tank
- c filler cap
- d hand pump
- e sight gauge (hidden from view)
- f hydraulic pump
- g motor
- h drain plug
- i hydraulic filter

- 4 Tag and disconnect the wire harness from the valve coils on the power unit.
- 5 Tag and disconnect the wire harness from the motor controller and 275A fuse.
- 6 Pull the trailer wiring harness through the power unit module bulkhead.

CHECKLIST E PROCEDURE

- 7 Tag, disconnect and plug the hydraulic hoses from the power unit. Cap the fittings.

Note: Do not disconnect the hydraulic filter lines from the power unit.

- 8 Tag and disconnect the brake line at the fitting under the motor controller.
- 9 Remove the hydraulic filter from the filter head.
- 10 Remove the power unit module retaining fasteners and remove the power unit module from the machine.
- 11 Remove the mounting fasteners that attach the hydraulic tank to the power unit. Remove the tank from the power unit.
- 12 Remove the pick-up filter. Clean the filter and tank using a mild solvent.
- 13 Install the pick-up filter onto the oil pick-up.
- 14 Apply thread sealant to the threads of the drain plug. Install the drain plug into the pump and tighten. Do not overtighten.
- 15 Install the hydraulic tank onto the power unit.

CAUTION Component damage hazard. The O-ring can be damaged if the hydraulic tank is not installed correctly. Use caution when installing the hydraulic tank onto the power unit.

- 16 Install the power unit onto the machine, and install and tighten the power unit retaining fasteners. Do not overtighten.
- 17 Apply a thin layer of fresh oil to the gasket of the new oil filter.

- 18 Install the hydraulic hoses onto the power unit. Torque to specification.

- 19 Install the brake line to the brake fitting under the motor controller and tighten the fitting. Do not overtighten.

- 20 Install the wire harness onto the motor controller and 275A fuse.

- 21 Route the trailer wiring harness through the module bulkhead and to the front of the trailer. Secure the wiring.

- 22 Install the wiring harness onto the valve coils at the power unit.

- 23 Fill the tank with hydraulic oil until the oil is visible in the sight gauge. Do not overfill. Refer to Section 2, *Specifications*.

- 24 Activate the pump to fill the hydraulic system with oil and bleed the system of air.

CAUTION Component damage hazard. The pump can be damaged if operated without oil. Be careful not to empty the hydraulic tank while in the process of filling the hydraulic system.

- 25 Repeat steps 23 through 24 until the hydraulic system and tank are both full.

- 26 Retract the outriggers and return the boom to the stowed position.

- 27 Clean up any oil that may have spilled. Properly discard the used oil and filter.

Repair Procedures



Observe and Obey:

- ☑ Repair procedures shall be completed by a person trained and qualified on the repair of this machine.
- ☑ Immediately tag and remove from service a damaged or malfunctioning machine.
- ☑ Repair any machine damage or malfunction before operating the machine.

Before Repairs Start:

- ☑ Read, understand and obey the safety rules and operating instructions in the appropriate Operator's Manual on your machine.
- ☑ Be sure that all necessary tools and parts are available and ready for use.
- ☑ Use only Genie approved replacement parts.
- ☑ Read each procedure completely and adhere to the instructions. Attempting shortcuts may produce hazardous conditions.
- ☑ Unless otherwise specified, perform each repair procedure with the machine in the following configuration:
 - Machine disconnected from tow vehicle
 - Machine parked on a firm, level surface
 - Boom in the stowed position with both latches secured
 - Key switch in the off position with the key removed
 - Wheels chocked
 - Parking brake applied

About This Section

Most of the procedures in this section should only be performed by a trained service professional in a suitably equipped workshop. Select the appropriate repair procedure after troubleshooting the problem.

Perform disassembly procedures to the point where repairs can be completed. Then to re-assemble, perform the disassembly steps in reverse order.

Symbols Legend



Safety alert symbol—used to alert personnel to potential personal injury hazards. Obey all safety messages that follow this symbol to avoid possible injury or death.

▲ DANGER

Indicates an imminently hazardous situation which, if not avoided, will result in death or serious injury.

▲ WARNING

Indicates a potentially hazardous situation which, if not avoided, could result in death or serious injury.

▲ CAUTION

Indicates a potentially hazardous situation which, if not avoided, may cause minor or moderate injury.

NOTICE

Indicates a potentially hazardous situation which, if not avoided, may result in property damage.

⦿ Indicates that a specific result is expected after performing a series of steps.

⊗ Indicates that an incorrect result has occurred after performing a series of steps.

Platform Components

1-1 Platform

How to Remove the Platform

- 1 Tag and disconnect the taillight control cable at the front of the platform.
- 2 Remove the platform rotate handle (if equipped).
- 3 Support and secure the platform to an appropriate lifting device. Do not apply any lifting pressure.
- 4 Remove the fasteners securing the platform to the platform mount bracket.
- 5 Remove the pin securing the platform to the platform rotator assembly.

⚠WARNING Crushing hazard. The platform could become unbalanced and fall if not properly supported when the pin is removed.

- 6 Remove the platform from the platform rotator assembly.

1-2 Platform Rotator (if equipped)

The platform rotator is a manually-operated gear assembly used to rotate the platform.

How to Remove the Platform Rotator

- 1 Remove the platform. See 1-1, *How to Remove the Platform*.
- 2 Tag and disconnect the platform control cable(s) from the platform controls.
- 3 Tag and disconnect the wiring at the power-to-platform junction box on the platform rotator assembly.
- 4 Completely loosen the shaft retaining fasteners at the bottom of the platform pivot shaft. Remove the platform rotate assembly from the machine.

PLATFORM COMPONENTS

How to Adjust the Platform Rotator

The platform rotator is designed to allow the platform to slip in the event of striking an object to help prevent damage to the platform. If the platform rotator is too tight or seized, damage to the platform may occur. If the platform rotator is too loose, the platform may rotate side to side unexpectedly, resulting in a unsafe operating condition.

- 1 Remove the platform. See 1-1, *How to Remove the Platform*.
- 2 Remove the platform rotate mount, platform mount and platform rotate gear assembly from the machine.
- 3 Remove the four bolts securing the cover over the rotate handle shaft. Remove the cover.
- 4 Remove the rotate handle shaft and pinion from the rotate gear case.
- 5 Remove the fasteners securing the rotate gear case to the gear shaft seal plate. Remove the case from the rotate gear assembly.
- 6 Remove the gear assembly retaining nut from the top of the shaft.

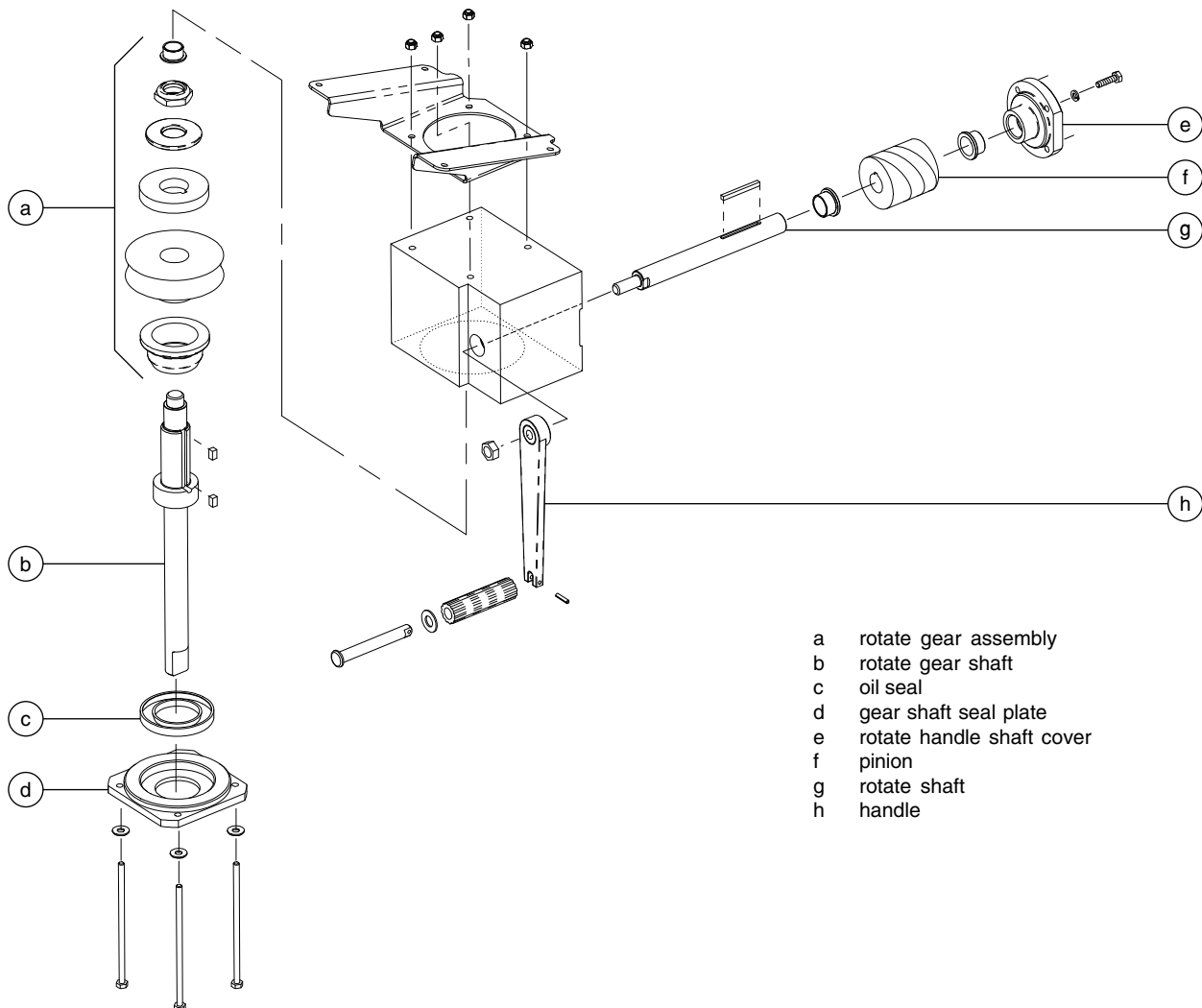

PLATFORM COMPONENTS

7 Disassemble the gear assembly.

Note: For ease of assembly, note the order of disassembly of the gear assembly.

8 Visually inspect the inside of the platform rotator for the following items:

- Excessive wear
- Broken or damaged parts
- Rust or corrosion
- Binding

NOTICE If any parts are lightly rusted or corroded, remove them and clean rust or corrosion off with a wire brush. If parts are worn, heavily rusted or corroded, replace them.

9 Remove the gear shaft from the shaft retainer bracket.

10 Thoroughly degrease and dry the case, covers and gear components.

11 Install the gear shaft fully into the shaft retainer bracket. Torque to specification.

12 Assemble the gear assembly in the reverse order of disassembly in step 7.

13 Install the gear assembly retaining nut onto the top of the shaft. Torque to specification.

14 Install the case over the gear assembly and onto the shaft seal plate. Install and securely tighten the retaining fasteners. Do not over tighten.

15 Thoroughly and heavily lubricate each tooth of the gear using multipurpose grease. Rotate the gear case as required.

NOTICE When lubricating the gear, do not apply any grease to the remainder of the gear assembly components. Grease on the balance of the gear components may result in slippage and poor rotator performance.

16 Install the rotate handle shaft and pinion into the rotate gear case.

17 Thoroughly and heavily lubricate each tooth of the pinion using multipurpose grease.

18 Install the rotate handle shaft cover. Install and securely tighten the cover fasteners. Do not over tighten.

Torque specification

Rotate gear shaft retainer bracket, dry	50 lbs-ft 68 Nm
Rotate gear nut, dry	200 lbs-ft 271 Nm

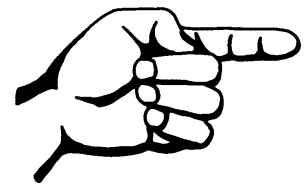

This page intentionally left blank.

Primary Boom Components

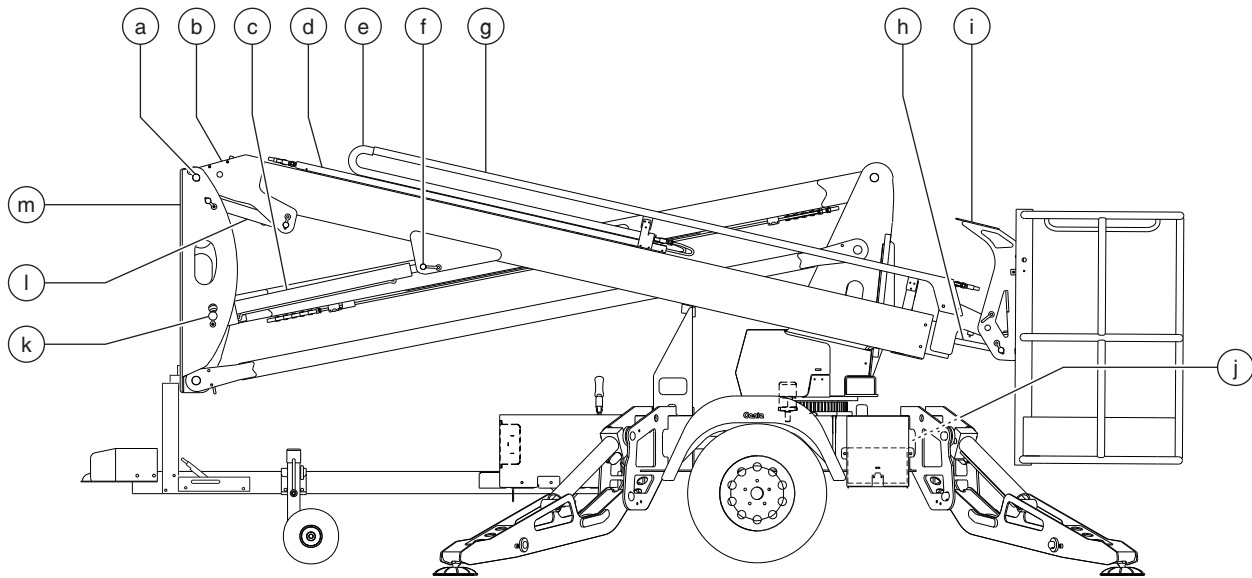

- | | | | |
|---|--|---|---|
| a | primary boom pivot pin | m | mid-pivot |
| b | primary boom | n | latch |
| c | primary boom lift cylinder | o | ground controls |
| d | cable tray | p | secondary boom lift cylinder barrel-end pivot pin |
| e | cable track | q | turntable |
| f | primary boom lift cylinder rod-end pivot pin | r | secondary boom pivot pin |
| g | cable bridge | s | secondary boom link pivot pin |
| h | platform level slave cylinder | t | secondary boom link |
| i | platform mount | u | secondary boom |
| j | battery charger | v | secondary boom lift cylinder |
| k | primary boom lift cylinder barrel-end AND secondary boom pivot pin | w | secondary lift cylinder rod-end pivot pin |
| l | platform level master cylinder | x | secondary boom link pivot pin |

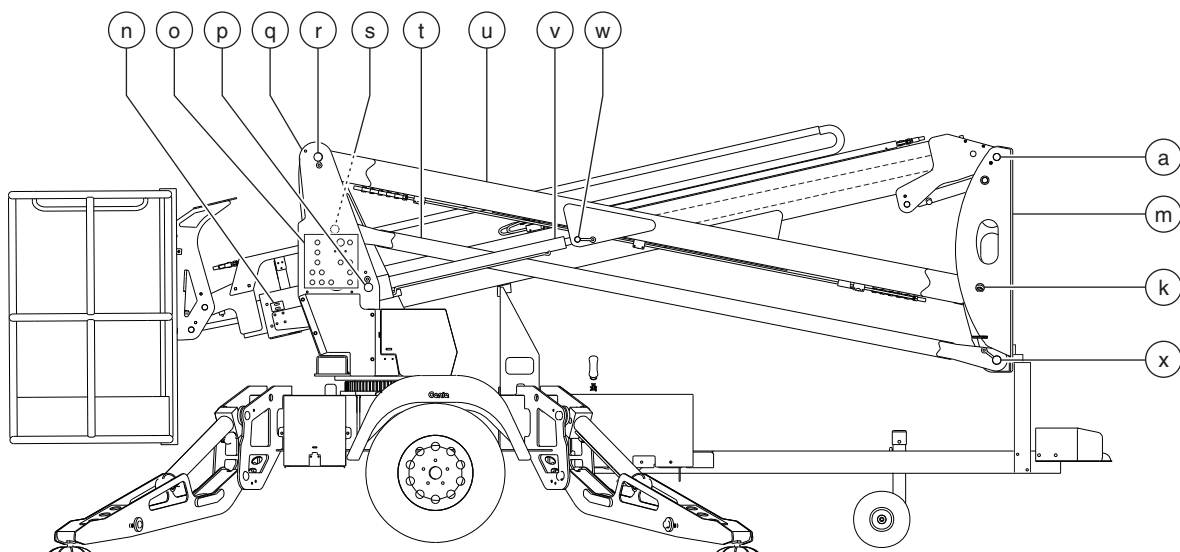

PRIMARY BOOM COMPONENTS

2-1 Cable Track

The boom cable track guides cables and hoses running up the boom. It can be repaired link by link without removing the cables and hoses that run through it. Removing the entire boom cable track may be necessary when performing major repairs that involve removing the boom.

How to Remove the Cable Track

Note: When removing a hose assembly or fitting, the O-ring on the fitting and/or hose end must be replaced and then torqued to specification during installation.

Refer to Section Two, *Hydraulic Hose and Fitting Torque Specifications*.

- 1 Working at the turntable, locate the three wire cables which are routed to the platform through the inside of the secondary boom.

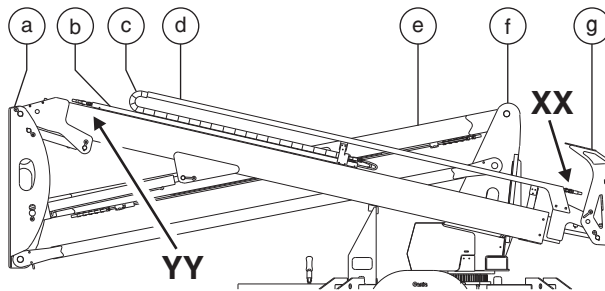

- a mid pivot
- b cable tray
- c cable track
- d cable bridge
- e secondary boom
- f turntable
- g platform mount

- 2 Tag and disconnect two of these wire cables from their source at the ground control box.
- 3 At the rear of the chassis, open the AC plug. Tag and disconnect the wiring from the plug. Remove the wiring from the clamp behind the battery charger cover.
- 4 Working from the mid pivot, pull the three wire cables through the turntable, secondary boom and mid pivot. Set the cables off to the side of the primary boom.

CAUTION Component damage hazard. Cables and hoses can be damaged if they are kinked or pinched.

- 5 Tag and disconnect the wire harness from the platform control box.
- 6 Tag and disconnect the trailer lighting wire harness at the platform. Remove the wiring from the clamp.
- 7 Remove the cover from the AC outlet. Tag and disconnect the wiring from the outlet.
- 8 Pull the three harness cables through the platform mount and lay them off to the side of the primary boom.

CAUTION Component damage hazard. Cables and hoses can be damaged if they are kinked or pinched.

- 9 Tag, disconnect and plug the hydraulic hoses at the platform end of the cable bridge. Cap the fittings on the hydraulic hard lines. Refer to 'XX' in the illustration.

WARNING Bodily injury hazard. Spraying hydraulic oil can penetrate and burn skin. Loosen hydraulic connections very slowly to allow the oil pressure to dissipate gradually. Do not allow oil to squirt or spray.

PRIMARY BOOM COMPONENTS

10 Tag, disconnect and plug the hydraulic hoses at the mid pivot end of the cable tray. Cap the fittings on the hydraulic hard lines. Refer to 'YY' in the illustration.

11 Place blocks between the cable bridge, cable track and cable tray. Secure them together.

WARNING Crushing hazard. If the cable bridge, cable track and cable tray are not properly secured together, the combination could become unbalanced and fall when removed from the machine.

12 Remove the fasteners securing the cable tray to the primary boom.

WARNING Crushing hazard. The cable track assembly could fall if not properly supported when the fasteners are removed.

13 Remove the fasteners securing the cable bridge to the extension boom.

14 Remove the cable track from the machine and place it on a structure capable of supporting it.

WARNING Crushing hazard. The cable track assembly could fall if not properly supported when removed from the machine.

How to Repair the Cable Track

CAUTION Component damage hazard. The cable track can be damaged if it is twisted.

- 1 Visually inspect the cable track and determine which 7 link section needs to be replaced.
- 2 Using a flat blade screwdriver, pry open the hinge bar on each link of the 7 link section, plus one more on each end making a total of 9.
- 3 Using a flat blade screwdriver at one side of the link to be replaced, separate the connection and open the joint slightly by sliding the link over the link pivot. Repeat for the other side of the link to separate the link sections.
- 4 Repeat step 3 for the other end of the section to be replaced.
- 5 Lift up the hoses and cables and carefully remove the damaged section of cable track.

CAUTION Component damage hazard. Hoses and cables can be damaged if they are kinked or pinched.

- 6 Lift up the hoses and cables and carefully insert the new section of cable track.
- 7 Install the new section of cable track onto the existing track. Be sure the link pivot on both sides of the link are in place and that the track hinges correctly
- 8 Securely lock the hinge bar for each link.
- 9 Operate the boom extend/retract function through a full cycle to ensure smooth operation of the new section of cable track.

PRIMARY BOOM COMPONENTS

2-2 Primary Boom

How to Shim the Primary Boom

- 1 Extend the boom until the wear pads are accessible.
- 2 Loosen the wear pad mounting fasteners.
- 3 Install the new shims under the wear pad to obtain zero clearance and zero drag.
- 4 Securely tighten the mounting fasteners. Do not overtighten.
- 5 Extend and retract the boom through an entire cycle. Check for tight spots that could cause binding or scraping.

NOTICE Always maintain squareness between the outer and inner boom tubes.

How to Remove the Primary Boom

WARNING This procedure in this section requires specific repair skills, lifting equipment and a suitable workshop. Attempting this procedure without these skills and tools could result in death or serious injury and significant component damage. Dealer service is required.

Note: Perform this procedure on a firm, level surface, with the boom in the stowed position.

Note: When removing a hose assembly or fitting, the O-ring on the fitting and/or hose end must be replaced and then torqued to specification during installation. Refer to Section 2, *Hydraulic Hose and Fitting Torque Specifications*.

- 1 Remove the platform. See 1-1, *How to Remove the Platform*.
- 2 Remove the cover under the ground controls.
- 3 Tag and disconnect the platform to ground control cable from the underside of the ground controls.

Note: Looking at the ground control box, the cable is at the far right and directly under the secondary boom up/down button.

- 4 Tag and disconnect the 8-pin wire harness connector behind the ground control box.

PRIMARY BOOM COMPONENTS

- 5 Remove the battery charger cover at the rear of the machine and remove the cable clamp securing the power-to-platform plug to the chassis near the battery charger.
- 6 Pull the cables from steps 3, 4 and 5 fully through the secondary boom and mid-pivot until they are clear of the mid-pivot. Carefully lay the cables over the primary boom.

CAUTION Component damage hazard. Cables and hoses can be damaged if they are kinked or pinched.

Note: For ease of assembly, pay close attention to how the cables are routed when pulling the cables through the boom and mid-pivot.

- 7 Tag, disconnect and plug the hydraulic hoses to the primary boom lift cylinder. Cap the fittings.

WARNING Bodily injury hazard. Spraying hydraulic oil can penetrate and burn skin. Loosen hydraulic connections very slowly to allow the oil pressure to dissipate gradually. Do not allow oil to squirt or spray.

CAUTION Component damage hazard. Cables and hoses can be damaged if they are kinked or pinched.

- 8 Attach a lifting strap of suitable capacity from an overhead crane to the primary boom lift cylinder.
- 9 Remove the pin retaining fasteners securing the primary boom lift cylinder pivot pin to the primary boom.
- 10 Using a soft metal drift, remove the primary boom lift cylinder pivot pin at the primary boom. Lower the cylinder onto the chassis.

WARNING Crushing hazard. The cylinder could fall if not properly supported when the pivot pin is removed.

- 11 Tag, disconnect and plug the hydraulic hoses to the platform level master cylinder. Cap the fittings.

WARNING Bodily injury hazard. Spraying hydraulic oil can penetrate and burn skin. Loosen hydraulic connections very slowly to allow the oil pressure to dissipate gradually. Do not allow oil to squirt or spray.

CAUTION Component damage hazard. Cables and hoses can be damaged if they are kinked or pinched.

- 12 Attach a lifting strap of suitable capacity from an overhead crane to the platform level master cylinder.
- 13 Remove the pin retaining fasteners securing the platform level master cylinder pivot pin to the primary boom. Lower the cylinder.
- 14 Using a soft metal drift, remove the platform level master cylinder pivot pin at the primary boom.

WARNING Crushing hazard. The cylinder could fall if not properly supported when the pivot pin is removed.

- 15 Tag, disconnect and plug the hydraulic hoses at the top of the primary boom near the mid-pivot. Cap the fittings.

WARNING Bodily injury hazard. Spraying hydraulic oil can penetrate and burn skin. Loosen hydraulic connections very slowly to allow the oil pressure to dissipate gradually. Do not allow oil to squirt or spray.

CAUTION Component damage hazard. Cables and hoses can be damaged if they are kinked or pinched.

PRIMARY BOOM COMPONENTS

16 Tag, disconnect and plug the hydraulic hoses to the primary boom extension cylinder at the mid pivot end of the primary boom. Cap the fittings.

▲WARNING Bodily injury hazard. Spraying hydraulic oil can penetrate and burn skin. Loosen hydraulic connections very slowly to allow the oil pressure to dissipate gradually. Do not allow oil to squirt or spray.

▲CAUTION Component damage hazard. Cables and hoses can be damaged if they are kinked or pinched.

17 Attach a lifting strap of suitable capacity from an overhead crane to the primary boom. Raise the boom to a horizontal position.

18 Remove the pin retaining fasteners securing the primary boom pivot pin to the mid-pivot.

19 Using a soft metal drift, remove the primary boom pivot pin at the mid-pivot.

▲WARNING Crushing hazard. The primary boom could become unbalanced and fall if not properly supported when the pin is removed.

20 Remove the primary boom from the machine.

▲WARNING Crushing hazard. The primary boom could become unbalanced and fall if not properly supported when removed from the machine.

How to Remove the Boom Extension

▲WARNING This procedure in this section requires specific repair skills, lifting equipment and a suitable workshop. Attempting this procedure without these skills and tools could result in death or serious injury and significant component damage. Dealer service is required.

Note: Perform this procedure on a firm level surface, boom in the stowed position.

Note: When removing a hose assembly or fitting, the O-ring on the fitting and/or hose end must be replaced and then torqued to specification during installation. Refer to Section 2, *Hydraulic Hose and Fitting Torque Specifications*.

- 1 Remove the primary boom. See 2-2, *How to Remove the Boom*.
- 2 Tag and disconnect the wiring at the power-to-platform junction box.
- 3 Tag and disconnect the cables from the platform control box.
- 4 Remove the platform controls and controls mounting bracket from the boom extension.

PRIMARY BOOM COMPONENTS

- 5 Attach a lifting strap of suitable capacity from an overhead crane to the platform mount. Do not apply any lifting pressure.
 - 6 Remove the pin retaining fasteners securing the platform mount pivot pin to the boom extension cylinder.
 - 7 Using a soft metal drift, remove the platform mount pivot pin at the boom extension cylinder.
AWARNING Crushing hazard. The platform mount could become unbalanced and fall if not properly supported when the pin is removed.
 - 8 Remove the pin retaining fasteners securing the platform mount pivot pin to the platform level slave cylinder.
 - 9 Using a soft metal drift, remove the platform mount pivot pin at the platform level slave cylinder.
AWARNING Crushing hazard. The platform mount could become unbalanced and fall if not properly supported when the pin is removed.
 - 10 Remove the wear pad retaining fasteners from the primary boom. Remove the wear pads from the boom.
- Note: For ease of assembly, note the quantity and location of shims during disassembly.
- 11 Tag, disconnect and plug the hydraulic hoses from the platform level slave cylinder at the cable track. Cap the fittings.
 - 12 Pull the boom extension out of the primary boom approximately 18 inches / 50 cm.
 - 13 Remove the pin retaining fasteners securing the barrel end of the extension cylinder to the extension boom at the platform end.
 - 14 Remove the retainer securing the hydraulic hoses at the platform end of the boom.
 - 15 Remove the pin retaining fasteners securing the platform level slave cylinder pivot pin to the boom extension.
 - 16 Using a soft metal drift, remove the platform level slave cylinder pivot pin.
 - 17 Remove the pin retaining fasteners securing the boom extension cylinder pivot pin to the primary boom.
 - 18 Using a soft metal drift, remove the boom extension cylinder pivot pin.
 - 19 Remove the boom extension and cylinder from the boom.

PRIMARY BOOM COMPONENTS

2-3 Primary Boom Lift Cylinder

The primary boom lift cylinder raises and lowers the primary boom. The primary boom lift cylinder is equipped with a bi-directional solenoid valve to prevent movement in the event of a hydraulic line failure.

How to Remove the Primary Boom Lift Cylinder

Note: When removing a hose assembly or fitting, the O-ring on the fitting and/or hose end must be replaced and then torqued to specification during installation. Refer to Section 2, *Hydraulic Hose and Fitting Torque Specifications*.

Note: Perform this procedure on a firm, level surface, with the boom in the stowed position and latched.

- 1 Tag, disconnect and plug the hydraulic hoses on the lift cylinder. Cap the fittings on the cylinder.

WARNING Bodily injury hazard. Spraying hydraulic oil can penetrate and burn skin. Loosen hydraulic connections very slowly to allow the oil pressure to dissipate gradually. Do not allow oil to squirt or spray.

- 2 Attach a lifting strap of suitable capacity from an overhead crane to the lift cylinder.
- 3 Remove the pin retaining fastener from the lift cylinder rod-end pivot pin.
- 4 Place a rod through the hole in the outrigger pivot pin and twist to remove the pin.

WARNING Crushing hazard. The lift cylinder will fall if not properly supported when the pivot pin is removed.

- 5 Lower the cylinder to a horizontal position.
- 6 Remove the pin retaining fastener from the lift cylinder barrel-end pivot pin.
- 7 Place a rod through the hole in the outrigger pivot pin and twist to remove the pin.

WARNING Crushing hazard. The lift cylinder will fall if not properly supported when the pivot pin is removed.

- 8 Carefully remove the cylinder from the machine.

WARNING Crushing hazard. The lift cylinder could become unbalanced and fall if not properly supported when removed from the machine.

CAUTION Component damage hazard. The solenoid valve can be damaged. Use caution when removing the cylinder from the machine.

PRIMARY BOOM COMPONENTS

2-4 Platform Leveling Cylinders

How to Remove the Master Cylinder

The master cylinder, located inside the mid pivot, acts as a pump for the slave cylinder, which is located at the platform end of the extension boom. The master cylinder operates in a closed-circuit hydraulic loop with the slave cylinder, keeping the platform level through the entire range of boom motion.

Note: When removing a hose assembly or fitting, the O-ring on the fitting and/or hose end must be replaced and then torqued to specification during installation.

Refer to Section Two, *Hydraulic Hose and Fitting Torque Specifications*.

- 1 Tag, disconnect and plug the master cylinder hydraulic hoses. Cap the fittings on the cylinder.

⚠ WARNING Bodily injury hazard. Spraying hydraulic oil can penetrate and burn skin. Loosen hydraulic connections very slowly to allow the oil pressure to dissipate gradually. Do not allow oil to squirt or spray.

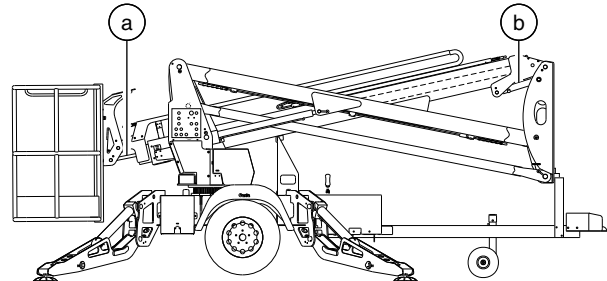

a platform level slave cylinder
b platform level master cylinder

- 2 Remove the pin retaining fastener from the master cylinder barrel end pivot pin.
- 3 Using a soft metal drift, remove the master cylinder barrel end pivot pin.
- 4 Attach a lifting strap from an overhead crane to the lug on the rod end of the master cylinder.
- 5 Remove the pin retaining fastener from the rod end pivot pin.
- 6 Using a soft metal drift, remove the master cylinder rod end pivot pin. Remove the master cylinder from the machine.

⚠ WARNING Crushing hazard. The master cylinder could become unbalanced and fall if not properly supported when removed from the machine.

PRIMARY BOOM COMPONENTS

How to Remove the Slave Cylinder

The slave cylinder, via a closed-circuit hydraulic loop, works in tandem with the master cylinder to maintain the platform in a level condition through the entire range of boom motion. The slave cylinder, located at the platform end of the extension boom, is equipped with counterbalance valves to prevent movement in the event of a hydraulic line failure.

Note: Before cylinder removal is considered to correct a malfunction, bleed the slave cylinder to be sure there is no air in the closed loop hydraulic circuit.

Note: When removing a hose assembly or fitting, the O-ring on the fitting and/or hose end must be replaced and then torqued to specification during installation. Refer to Section Two, *Hydraulic Hose and Fitting Torque Specifications*.

- 1 Extend the boom approximately 12 inches / 30 cm.
- 2 Tag, disconnect and plug the slave cylinder hydraulic hoses from the tee fittings on the jib manifold, and connect them together using a connector. Cap the fittings on the manifold.

⚠ WARNING Bodily injury hazard. Spraying hydraulic oil can penetrate and burn skin. Loosen hydraulic connections very slowly to allow the oil pressure to dissipate gradually. Do not allow oil to squirt or spray.

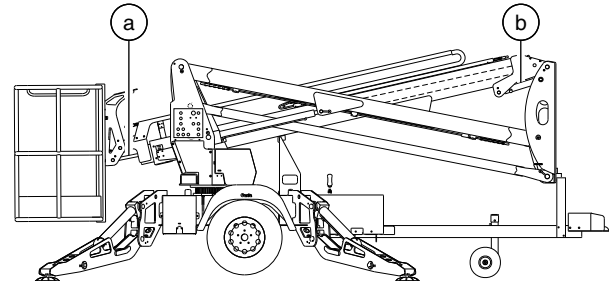

a platform level slave cylinder
b platform level master cylinder

- 3 Remove the pin retaining fastener from the slave cylinder rod end pivot pin. Do not remove the pin.
- 4 Remove the external retaining rings from the barrel end pivot pin.
- 5 Using a soft metal drift, remove the rod end pivot pin.
- 6 Carefully pull the cylinder out of the boom.

CAUTION Component damage hazard. Hoses can be damaged if they are kinked or pinched.

How to Bleed the Slave Cylinder

- 1 Raise the boom to a horizontal position.
- 2 Activate the platform level function in both up and down directions through two complete platform leveling cycles to remove any air that might be in the system.

The master cylinder acts as a pump for the slave cylinder. It is part of the closed loop hydraulic circuit that keeps the platform level through the entire range of boom motion. The master cylinder is located inside the mid pivot.

Secondary Boom Components

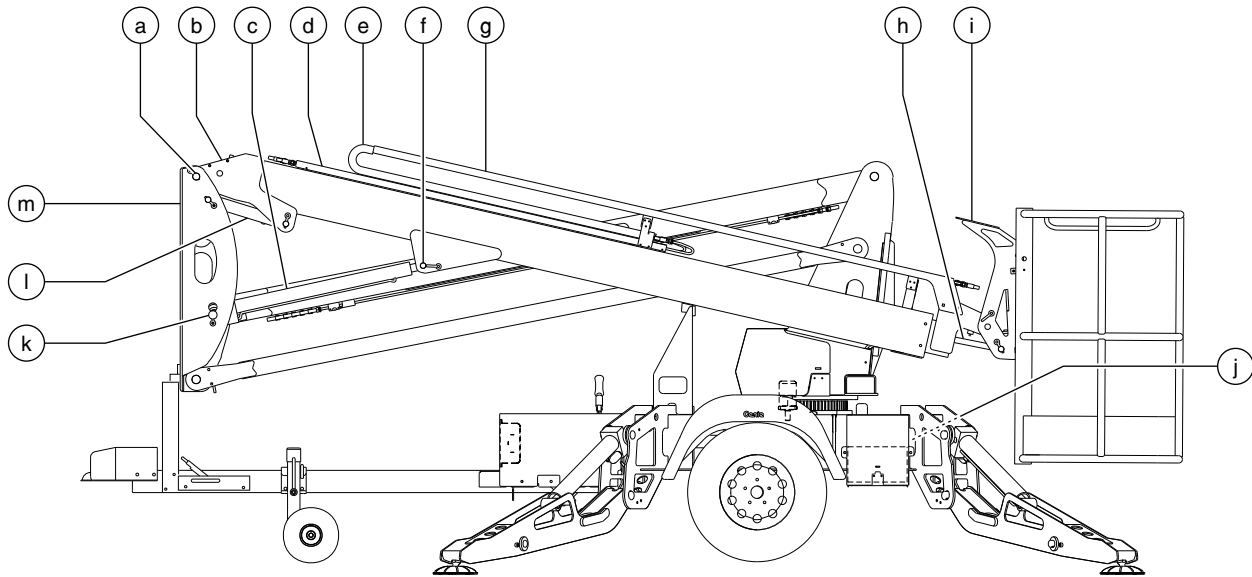

- | | | | |
|---|--|---|---|
| a | primary boom pivot pin | m | mid-pivot |
| b | primary boom | n | latch |
| c | primary boom lift cylinder | o | ground controls |
| d | cable tray | p | secondary boom lift cylinder barrel-end pivot pin |
| e | cable track | q | turntable |
| f | primary boom lift cylinder rod-end pivot pin | r | secondary boom pivot pin |
| g | cable bridge | s | secondary boom link pivot pin |
| h | platform level slave cylinder | t | secondary boom link |
| i | platform mount | u | secondary boom |
| j | battery charger | v | secondary boom lift cylinder |
| k | primary boom lift cylinder barrel-end AND secondary boom pivot pin | w | secondary lift cylinder rod-end pivot pin |
| l | platform level master cylinder | x | secondary boom link pivot pin |

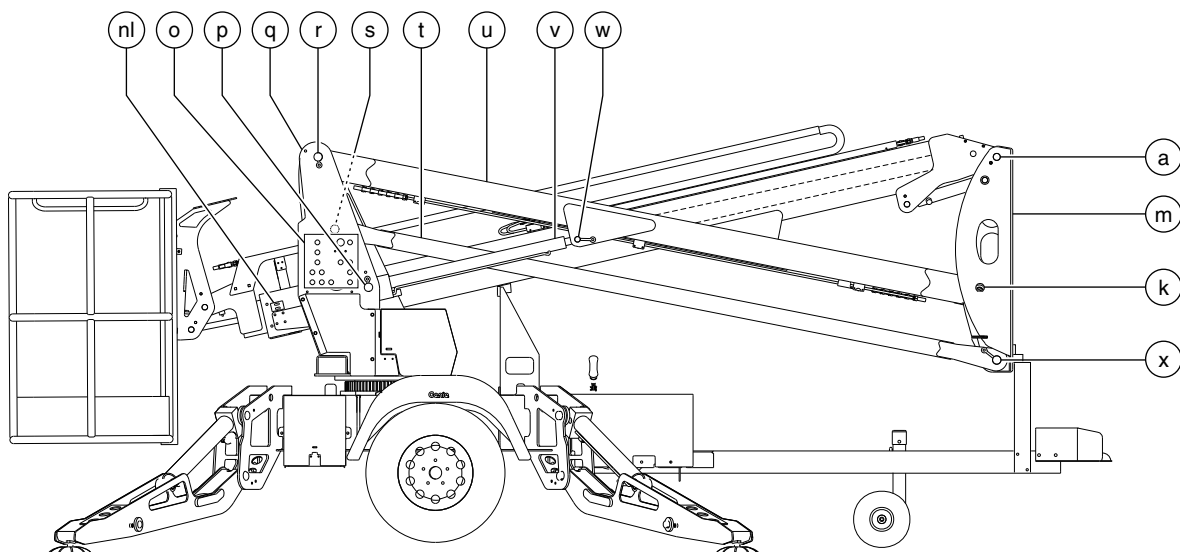

SECONDARY BOOM COMPONENTS

3-1 Secondary Boom

How to Remove the Secondary Boom

▲WARNING This procedure in this section requires specific repair skills, lifting equipment and a suitable workshop. Attempting this procedure without these skills and tools could result in death or serious injury and significant component damage. Dealer service is required.

Note: Perform this procedure on a firm, level surface, with the boom in the stowed position.

Note: When removing a hose assembly or fitting, the O-ring on the fitting and/or hose end must be replaced and then torqued to specification during installation.

Refer to Section 2, *Hydraulic Hose and Fitting Torque Specifications*.

- 1 Remove the primary boom. See 2-2, *How to Remove the Primary Boom*.

Remove the mid-pivot

- 2 Attach a lifting strap of suitable capacity from an overhead crane to the primary lift cylinder. Raise the cylinder to a horizontal position.
- 3 Remove the pin retaining fasteners securing the primary lift cylinder pivot pin to the mid-pivot.
- 4 Using a soft metal drift, remove the primary lift cylinder pivot pin at the mid-pivot.

▲WARNING Crushing hazard. The cylinder could fall if not properly supported when the pivot pin is removed.

- 5 Attach a lifting strap of suitable capacity from an overhead crane to the mid-pivot. Do not apply any lifting pressure.
- 6 Remove the pin retaining fasteners securing the secondary boom pivot pin to the mid-pivot.
- 7 Remove the pin retaining fasteners securing the secondary link pivot pin to the mid-pivot.
- 8 Remove the hose clamps securing the hydraulic hoses to the mid-pivot.
- 9 Tag, disconnect and plug the hydraulic hoses to the hydraulic hard lines at the mid-pivot end of the secondary boom. Cap the fittings.

▲WARNING Bodily injury hazard. Spraying hydraulic oil can penetrate and burn skin. Loosen hydraulic connections very slowly to allow the oil pressure to dissipate gradually. Do not allow oil to squirt or spray.

CAUTION Component damage hazard. Cables and hoses can be damaged if they are kinked or pinched.

SECONDARY BOOM COMPONENTS

10 Attach a lifting strap of suitable capacity from an overhead crane to the secondary link. Do not apply any lifting pressure.

11 Using a soft metal drift, remove the secondary boom pivot pin at the mid-pivot.

▲WARNING Crushing hazard. The mid-pivot could become unbalanced and fall if not properly supported when the pin is removed.

12 Using a soft metal drift, remove the secondary link pivot pin at the mid-pivot.

▲WARNING Crushing hazard. The secondary link could become unbalanced and fall if not properly supported when the pin is removed.

13 Remove the mid-pivot from the machine.

▲WARNING Crushing hazard. The mid-pivot could become unbalanced and fall if not properly supported when removed from the machine.

Remove the secondary boom

14 Remove the pin retaining fasteners securing the secondary link pivot pin to the turntable.

15 Using a soft metal drift, remove the secondary link pivot pin.

▲WARNING Crushing hazard. The secondary link could become unbalanced and fall if not properly supported when the pin is removed.

16 Remove the secondary link from the machine.

17 Attach a lifting strap of suitable capacity from an overhead crane to the lift cylinder. Do not apply any lifting pressure.

18 Remove the pin retaining fasteners securing the lift cylinder pivot pin to the secondary boom.

19 Using a soft metal drift, remove the lift cylinder pivot pin from the secondary boom. Lower the cylinder.

▲WARNING Crushing hazard. The cylinder could fall if not properly supported when the pivot pin is removed.

20 Tag, disconnect and plug the hydraulic hoses to the hydraulic hard lines at the turntable end of the secondary boom. Cap the fittings.

▲WARNING Bodily injury hazard. Spraying hydraulic oil can penetrate and burn skin. Loosen hydraulic connections very slowly to allow the oil pressure to dissipate gradually. Do not allow oil to squirt or spray.

CAUTION Component damage hazard. Cables and hoses can be damaged if they are kinked or pinched.

21 Attach a lifting strap of suitable capacity from an overhead crane to the secondary boom. Raise the boom to a horizontal position.

22 Remove the pin retaining fasteners securing the secondary boom pivot pin to the turntable.

23 Using a soft metal drift, remove the secondary boom pivot pin.

▲WARNING Crushing hazard. The secondary boom could become unbalanced and fall if not properly supported when the pin is removed.

24 Remove the secondary boom from the machine.

SECONDARY BOOM COMPONENTS

3-2 Secondary Boom Lift Cylinder

The primary boom lift cylinder raises and lowers the primary boom. The primary boom lift cylinder is equipped with a bi-directional solenoid valve to prevent movement in the event of a hydraulic line failure.

How to Remove the Secondary Boom Lift Cylinder

Note: When removing a hose assembly or fitting, the O-ring on the fitting and/or hose end must be replaced and then torqued to specification during installation.

Refer to Section 2, *Hydraulic Hose and Fitting Torque Specifications*.

Note: Perform this procedure on a firm, level surface, with the boom in the stowed position.

- 1 Tag, disconnect and plug the hydraulic hoses on the lift cylinder. Cap the fittings on the cylinder.

WARNING Bodily injury hazard. Spraying hydraulic oil can penetrate and burn skin. Loosen hydraulic connections very slowly to allow the oil pressure to dissipate gradually. Do not allow oil to squirt or spray.

- 2 Attach a lifting strap of suitable capacity from an overhead crane to the lift cylinder.
- 3 Remove the pin retaining fastener from the lift cylinder rod-end pivot pin.
- 4 Place a rod through the hole in the outrigger pivot pin and twist to remove the pin.

WARNING Crushing hazard. The lift cylinder will fall if not properly supported when the pivot pin is removed.

- 5 Lower the cylinder to a horizontal position.
- 6 Remove the pin retaining fastener from the lift cylinder barrel-end pivot pin.
- 7 Place a rod through the hole in the outrigger pivot pin and twist to remove the pin.

WARNING Crushing hazard. The lift cylinder will fall if not properly supported when the pivot pin is removed.

- 8 Carefully remove the cylinder from the machine.

WARNING Crushing hazard. The lift cylinder could become unbalanced and fall if not properly supported when removed from the machine.

CAUTION Component damage hazard. The solenoid valve can be damaged. Use caution when removing the cylinder from the machine.

Ground Controls

4-1 Level Sensor

Each machine is equipped with two types of level sensors:

Tilt level sensor

One level sensor monitors the incline of the turntable after the outriggers are deployed and the machine is level. When this level sensor activates, an alarm will sound, making the operator aware of a potentially hazardous situation.

The tilt alarm sounds when the incline of the chassis exceeds 2.5° in any direction. The tilt level sensor is located on the side of the machine opposite the ground controls.

Outrigger auto level system

When deploying the outriggers using the autolevel function, outrigger level sensors are used to monitor the incline of the turntable and assist in leveling the machine.

In early production, two level sensors are components of the outrigger auto level circuit. Later in production, a single autolevel module was used. The outrigger level sensor(s) are located on the ground controls side of the machine.

How to Install and Calibrate the Tilt Level Sensor

⚠ DANGER Tip-over hazard. Failure to install or calibrate the level sensor as instructed could result in the machine tipping over causing death or serious injury. Do not install or calibrate the level sensor other than specified in this procedure.

- 1 Perform this procedure with the machine on a firm, level surface that is free of obstructions.

- 2 Turn the key switch to ground control and pull out the red Emergency Stop buttons to the on position at both the ground and platform controls.
- 3 Push and hold the yellow function enable button. Push and hold the auto level button.
 - ⦿ Result: The outriggers will lower and adjust to level the machine and raise the wheels off the ground. Use the bubble levels located on the chassis to confirm that the machine is level.
- 4 Turn the key switch to the off position.
- 5 Locate the tilt level sensor behind the inspection door on the side of the machine opposite the ground controls.

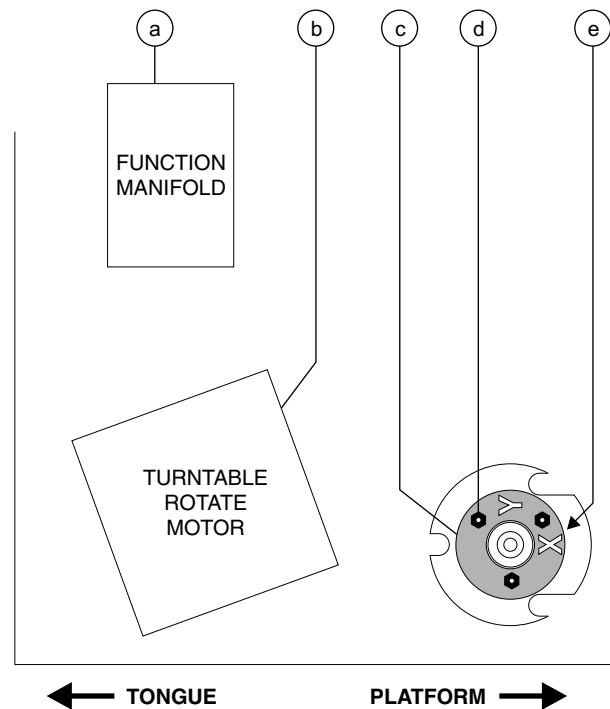

- a function manifold
- b turntable rotate motor
- c tilt level sensor
- d adjusting fastener
- e "X" indicator

GROUND CONTROLS

If you are not installing a new level sensor, proceed to step 10.

Install the level sensor:

- 6 Tag and disconnect the wire harness from the tilt level sensor.
 - 7 Remove the three level sensor retaining fasteners. Remove the level sensor from the machine.
 - 8 Install the new level sensor onto the machine with the "X" on the level sensor housing located as shown in the illustration. Install and tighten the level sensor retaining fasteners.
 - 9 Connect the wire harness to the level sensor.
 - 10 Tighten the level sensor adjusting fasteners until the bubble in the top of the level sensor is centered in the circles.
- Note: Be sure there are threads showing through the top of the adjusting fasteners.
- 11 Turn the key switch to ground control and pull out the red Emergency Stop buttons to the on position at both the ground and platform controls.
 - 12 Raise the secondary boom approximately 12 inches / 30 cm.
 - ⦿ Result: The tilt sensor alarm should not sound.
 - 13 Using a digital level, lower the tank side of the machine until the turntable is 2.4° out of level.
 - ⦿ Result: The tilt sensor alarm should not sound.
 - ✗ Result: The tilt alarm will sound at 180 beeps per minute. The level sensor is faulty and must be replaced. Repeat this procedure beginning with step 6.
 - 14 Continue to lower the tank side of the machine until the turntable is 2.7° out of level.
 - ⦿ Result: The tilt alarm will sound at 180 beeps per minute.
 - ✗ Result: The tilt alarm does not sound. The level sensor is faulty and must be replaced. Repeat this procedure beginning with step 6.
 - 15 Push and hold the yellow function enable button. Push and hold the auto level button.
 - ⦿ Result: The outriggers will lower and adjust to level the machine and raise the wheels off the ground. Use the bubble level located below the ground controls to confirm that the machine is level.
 - 16 Using a digital level, lower the ground control side of the machine until the turntable is 2.4° out of level.
 - ⦿ Result: The tilt sensor alarm should not sound.
 - ✗ Result: The tilt alarm will sound at 180 beeps per minute. The level sensor is faulty and must be replaced. Repeat this procedure beginning with step 6.
 - 17 Continue to lower the ground control side of the machine until the turntable is 2.7° out of level.
 - ⦿ Result: The tilt alarm will sound at 180 beeps per minute.
 - ✗ Result: The tilt alarm does not sound. The level sensor is faulty and must be replaced. Repeat this procedure beginning with step 6.
 - 18 Push and hold the yellow function enable button. Push and hold the auto level button.
 - ⦿ Result: The outriggers will lower and adjust to level the machine and raise the wheels off the ground. Use the bubble level located below the ground controls to confirm that the machine is level.

GROUND CONTROLS

- 19 Using a digital level, lower the platform end of the machine until the turntable is 2.4° out of level.
- ⦿ Result: The tilt sensor alarm should not sound.
 - ✘ Result: The tilt alarm will sound at 180 beeps per minute. The level sensor is faulty and must be replaced. Repeat this procedure beginning with step 6.
- 20 Continue to lower the platform end of the machine until the turntable is 2.7° out of level.
- ⦿ Result: The tilt alarm will sound at 180 beeps per minute.
 - ✘ Result: The tilt alarm does not sound. The level sensor is faulty and must be replaced. Repeat this procedure beginning with step 6.
- 21 Push and hold the yellow function enable button. Push and hold the auto level button.
- ⦿ Result: The outriggers will lower and adjust to level the machine and raise the wheels off the ground. Use the bubble level located below the ground controls to confirm that the machine is level.
- 22 Using a digital level, lower the tongue end of the machine until the turntable is 2.4° out of level.
- ⦿ Result: The tilt sensor alarm should not sound.
 - ✘ Result: The tilt alarm will sound at 180 beeps per minute. The level sensor is faulty and must be replaced. Repeat this procedure beginning with step 6.
- 23 Continue to lower the tongue end of the machine until the turntable is 2.7° out of level.
- ⦿ Result: The tilt alarm will sound at 180 beeps per minute.
 - ✘ Result: The tilt alarm does not sound. The level sensor is faulty and must be replaced. Repeat this procedure beginning with step 6.
- 24 Return the outriggers to the stowed position.

How to Install and Calibrate the Outrigger Level Sensor

⚠ DANGER

Tip-over hazard. Failure to install or calibrate the level sensor as instructed could result in the machine tipping over causing death or serious injury. Do not install or calibrate the level sensor other than specified in this procedure.

- 1 Perform this procedure with the machine on a firm, level surface that is free of obstructions.
- 2 Turn the key switch to ground control and pull out the red Emergency Stop buttons to the on position at both the ground and platform controls.
- 3 Lower all four outriggers and raise the machine off the ground. Level the machine. Use the bubble level located below the ground controls to confirm that the machine is level.
- 4 Turn the key switch to the off position.

GROUNDCONTROLS

- 5 Locate the outrigger level sensor(s) behind the inspection door on the ground control side of the machine.

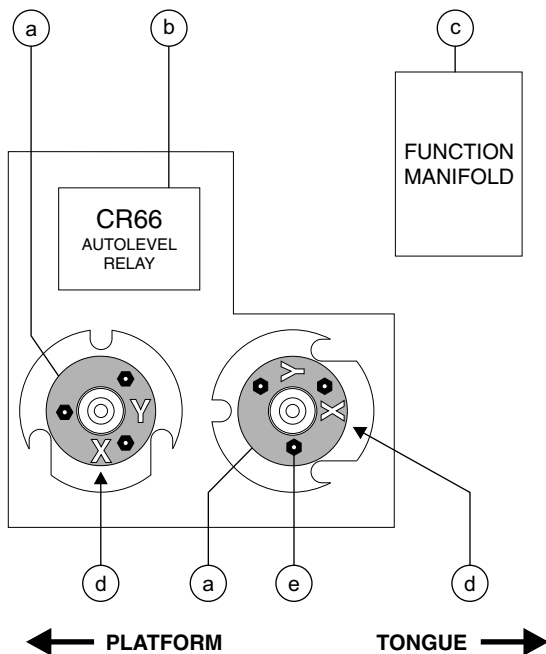

- a outrigger level sensor
- b autolevel relay (early production)
- c function manifold
- d "X" indicator
- e adjusting fastener

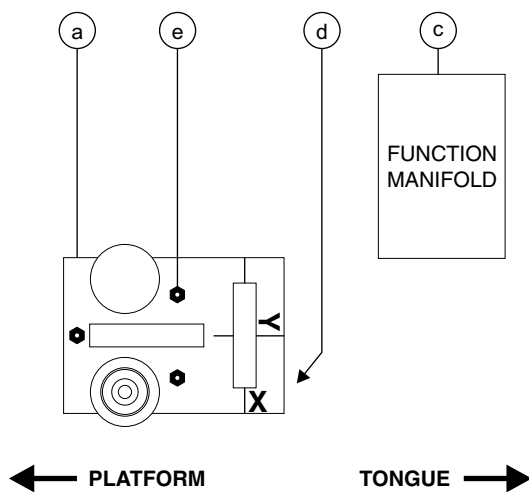

If you are not installing a new level sensor, proceed to step 10.

- 6 Tag and disconnect the wire harness from the outrigger level sensor.
- 7 Remove the three level sensor retaining fasteners. Remove the level sensor from the machine.
- 8 Install the new level sensor onto the machine with the "X" on the level sensor housing located as shown in the illustrations. Install and tighten the level sensor retaining fasteners.
- 9 Connect the wire harness to the level sensor.
- 10 Tighten the level sensor adjusting fasteners until the bubble in the top of the level sensor is centered in the circles.

Note: e sure there are threads showing through the top of the adjusting fasteners.

- 11 Turn the key switch to ground control.
 - 12 Raise the outriggers until all of the outriggers are off the ground.
 - 13 Push and hold the yellow function enable button. Push and hold the auto level button.
- ⊙ Result: The outriggers will lower and adjust to level the machine and raise the wheels off the ground. Use the bubble level located below the ground controls to confirm that the machine is level.

Hydraulic Power Unit

5-1

Hydraulic Power Unit Components To Serial Number TZ3412-298

The power unit is located under the side cover on the side of the machine opposite of the ground controls.

Index No.	Description	Schematic Item	Function	Torque
1	Hand pump		Auxiliary functions	
2	Dipstick/breather		Fluid level	
3	Hose fitting		To outrigger extend front circuit	10-12 ft-lbs / 14-16 Nm
4	Hose fitting		To outrigger extend rear circuit	10-12 ft-lbs / 14-16 Nm
5	Diagnostic nipple	A	Testing	10-12 ft-lbs / 14-16 Nm
6	24V DC electric motor		Operates hydraulic pump	50 in-lbs / 5.5 Nm
7	Solenoid valve, 3 position 4 way (closed center)	B	Outrigger extend/retract	28-33 ft-lbs / 38-44 Nm
—	Coil nut			60 in-lbs / 6.7 Nm
8	Valve coil		Outrigger extend function	
9	Valve coil		Outrigger retract function	
10	Check valve	C	Outrigger circuit	
11	Hydraulic filter		Filters hydraulic fluid leaving system	
12	Power unit valve body			
13	Pump (to Serial Number TZ3407-483)		1.65 gallons per minute @ 3500 psi 6.25 liters per minute @ 241.3 bar	
13	Pump (from Serial Number TZ3407-484)		1.3 gallons per minute @ 3500 psi 4.9 liters per minute @ 241.3 bar	
14	Pick-up filter		Filters hydraulic fluid entering the pump	
15	Tank		2.1 gallons / 8 liters	50 in-lbs / 5.5 Nm
16	Breather filter (from serial number TZ3403-330)		Vents tank to atmosphere	
17	Relief valve	D	Outrigger system relief	28-33 ft-lbs / 38-44 Nm
18	Hose fitting		To outrigger retract front circuit	10-12 ft-lbs / 14-16 Nm
19	Hose fitting		To outrigger retract rear circuit	10-12 ft-lbs / 14-16 Nm
20	Hose fitting		To function manifold "T"	10-12 ft-lbs / 14-16 Nm
21	Relief valve	E	System relief	28-33 ft-lbs / 38-44 Nm
22	Check valve	F	Auxiliary pump circuit	28-33 ft-lbs / 38-44 Nm
23	Hose fitting		To function manifold "P"	10-12 ft-lbs / 14-16 Nm
24	Sight gauge	G	Hydraulic fluid level	106 in-lbs / 12 Nm

HYDRAULIC POWER UNIT

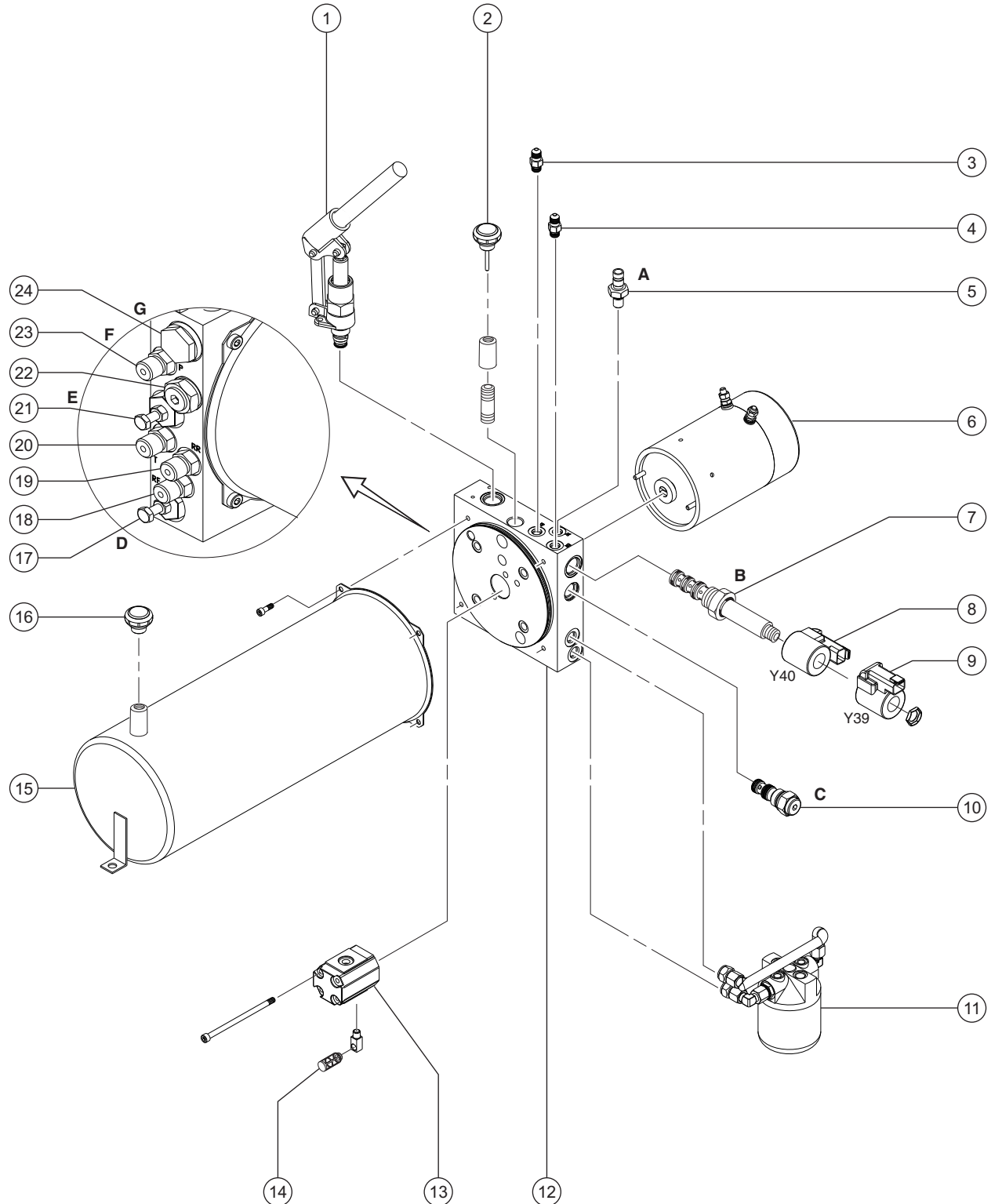

HYDRAULIC POWER UNIT

5-2 Hydraulic Power Unit Components From Serial Number TZ3412-299

The power unit is located under the side cover on the side of the machine opposite of the ground controls.

Index No.	Description	Schematic Item	Function	Torque
1	Hand pump		Auxiliary functions	
2	Breather Cap W/Check Valve		Fluid fill / Vents to atmosphere	
3	Hose fitting		To outrigger extend front circuit	10-12 ft-lbs / 14-16 Nm
4	Manifold Plug			10-12 ft-lbs / 14-16 Nm
5	Diagnostic nipple	A	Testing	10-12 ft-lbs / 14-16 Nm
6	24V DC electric motor		Operates hydraulic pump	50 in-lbs / 5.5 Nm
7	Solenoid valve, 3 position 4 way (open center)	B	Outrigger extend/retract	28-33 ft-lbs / 38-44 Nm
—	Coil nut			60 in-lbs / 6.7 Nm
8	Valve coil		Outrigger extend function	
9	Valve coil		Outrigger retract function	
10	Check valve	C	Outrigger circuit	
11	Hydraulic filter		Filters hydraulic fluid leaving system	
12	Power unit valve body			
13	Pump		1.3 gallons per minute @ 3500 psi 4.9 liters per minute @ 241.3 bar	
14	Pick-up filter		Filters hydraulic fluid entering the pump	
15	Tank		2.1 gallons / 8 liters	50 in-lbs / 5.5 Nm
16	Breather Cap W/Check Valve		Vents tank to atmosphere	
17	Relief valve	D	Outrigger system relief	28-33 ft-lbs / 38-44 Nm
18	Hose fitting		To outrigger retract front circuit	10-12 ft-lbs / 14-16 Nm
19	Manifold Plug			10-12 ft-lbs / 14-16 Nm
20	Hose fitting		To function manifold "T"	10-12 ft-lbs / 14-16 Nm
21	Relief valve	E	System relief	28-33 ft-lbs / 38-44 Nm
22	Check valve	F	Auxiliary pump circuit	28-33 ft-lbs / 38-44 Nm
23	Hose fitting		To function manifold "P"	10-12 ft-lbs / 14-16 Nm
24	Sight gauge	G	Hydraulic fluid level	106 in-lbs / 12 Nm

HYDRAULIC POWER UNIT

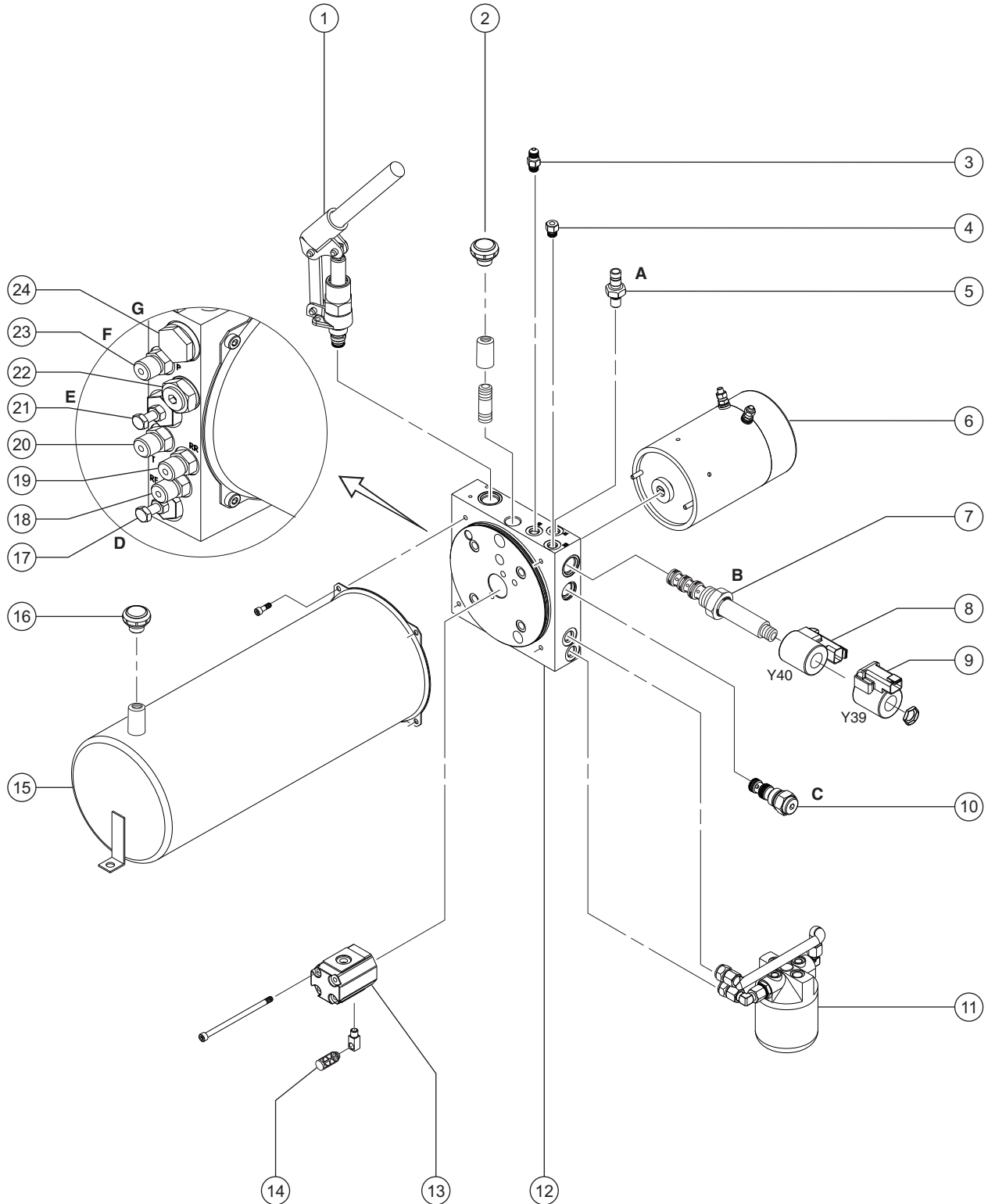

HYDRAULIC POWER UNIT

5-3 Valve Adjustments - Hydraulic Power Unit

How to Adjust the System Relief Valve

- 1 Connect a 0 to 5000 psi / 0 to 350 bar pressure gauge to the test port on the hydraulic power unit (schematic item A).
- 2 Turn the key switch to ground controls and pull out the red Emergency Stop button to the on position at both the ground and platform controls.
- 3 Fully raise the primary boom.
- 4 Press and hold the platform up function enable button and press and hold the primary boom up/down button and observe the pressure reading on the pressure gauge. Turn the machine off.
- 5 Hold the relief valve adjusting screw and loosen the lock nut (schematic item E).
- 6 Adjust the relief valve screw. Turn it clockwise to increase the pressure or counterclockwise to decrease the pressure. Refer to Section 2, *Specifications*.
- 7 Hold the relief valve screw and securely tighten the lock nut. Be sure the relief valve screw does not turn.
- 8 Repeat step 4 to confirm the relief valve pressure setting.
- 9 Bleed the hydraulic system by raising the platform to full height. If the pump cavitates or platform fails to reach full height, add hydraulic oil until the pump is functioning correctly. Do not overfill the hydraulic tank.

CAUTION Component damage hazard. Do not continue to operate the machine if the hydraulic pump is cavitating.

⚠ DANGER Tip-over hazard. Do not adjust the relief valve higher than specified.

- 7 Hold the relief valve screw and securely tighten the lock nut. Be sure the relief valve screw does not turn.

HYDRAULIC POWER UNIT

5-4 Hydraulic Pump

How to Remove the Hydraulic Power Unit

Note: When removing a hose assembly or fitting, the O-ring on the fitting and/or hose end must be replaced and then torqued to specification during installation. Refer to Section 2, *Hydraulic Hose and Fitting Torque Specifications*.

- 1 Disconnect the battery pack from the machine.

WARNING Electrocutation hazard. Contact with electrically charged circuits may result in death or serious injury. Remove all rings, watches and other jewelry.

- 2 Remove the drain plug from the hydraulic pump valve body and completely drain the tank into a suitable container. Refer to Section 2, *Specifications*, for capacity information.
- 3 Tag, disconnect and plug the hydraulic hoses. Cap the fittings on the power unit.

WARNING Bodily injury hazard. Spraying hydraulic oil can penetrate and burn skin. Loosen hydraulic connections very slowly to allow the oil pressure to dissipate gradually. Do not allow oil to squirt or spray.

- 4 Tag and disconnect the electrical wiring from the valve coils.

- 5 Tag and disconnect the power cables from the hydraulic power unit motor.

WARNING Electrocutation hazard. Contact with electrically charged circuits may result in death or serious injury. Remove all rings, watches and other jewelry.

- 6 Remove the power unit mounting fasteners and remove the power unit from the machine.

NOTICE If a new power unit is installed, the pressure relief valve must be properly adjusted. See 5-3, *How to Adjust the System Relief Valve*.

How to Remove the Hydraulic Pump

- 1 Remove the power unit.
- 2 Remove the hydraulic tank from the power unit valve body.
- 3 Remove the pump mounting fasteners and remove the pump from the valve body.

CAUTION Component damage hazard. Improper alignment during assembly can damage the pump-to-motor seal. Use caution when installing the pump.

Manifolds

6-1

Function Manifold Components (to serial number TZ3403-248)

The function manifold is located under the turntable cover.

Index No.	Description	Schematic Item	Function	Torque
1	Flow regulator, 0.4 gpm / 1.5 L/min	H	Platform level/turntable rotate circuit...	7-8 ft-lbs / 9.5-10.5 Nm
2	Flow control	I	Turntable rotate speed	18-22 ft-lbs / 25-30 Nm
3	Relief valve, 1200 psi / 82.7 bar	J	Turntable rotate circuit	7-8 ft-lbs / 9.5-10.5 Nm
4	Solenoid valve, 3 position 4 way	K	Turntable rotate left/right	7-8 ft-lbs / 9.5-10.5 Nm
5	Counterbalance valve	L	Platform level up circuit	19-22 ft-lbs / 25-30 Nm
6	Solenoid valve, 3 position 4 way	M	Platform level	7-8 ft-lbs / 9.5-10.5 Nm
7	Counterbalance valve	N	Platform level down circuit	19-22 ft-lbs / 25-30 Nm
8	Solenoid valve, 2 position 3 way with manual override	O	Fluid regeneration, boom extend circuit	19-22 ft-lbs / 25-30 Nm
9	Relief valve, 1800 psi / 124.1 bar	P	Boom extend circuit	11-13 ft-lbs / 15-17 Nm
10	Solenoid valve, 3 position 4 way with manual override	Q	Primary boom up/down	7-8 ft-lbs / 9.5-10.5 Nm
11	Relief valve, 1600 psi / 110.3 bar	R	Primary boom circuit	11-13 ft-lbs / 15-17 Nm
12	Relief valve, 1100 psi / 75.8 bar	S	Secondary boom circuit	11-13 ft-lbs / 15-17 Nm
13	Solenoid valve, 3 position 4 way with manual override	T	Secondary boom up/down	7-8 ft-lbs / 9.5-10.5 Nm
14	Relief valve, 1200 psi / 82.7 bar	U	Turntable rotate circuit	11-13 ft-lbs / 15-17 Nm
15	Solenoid valve, 2 position 3 way with manual override	V	Boom extend/retract	19-22 ft-lbs / 25-30 Nm

MANIFOLDS

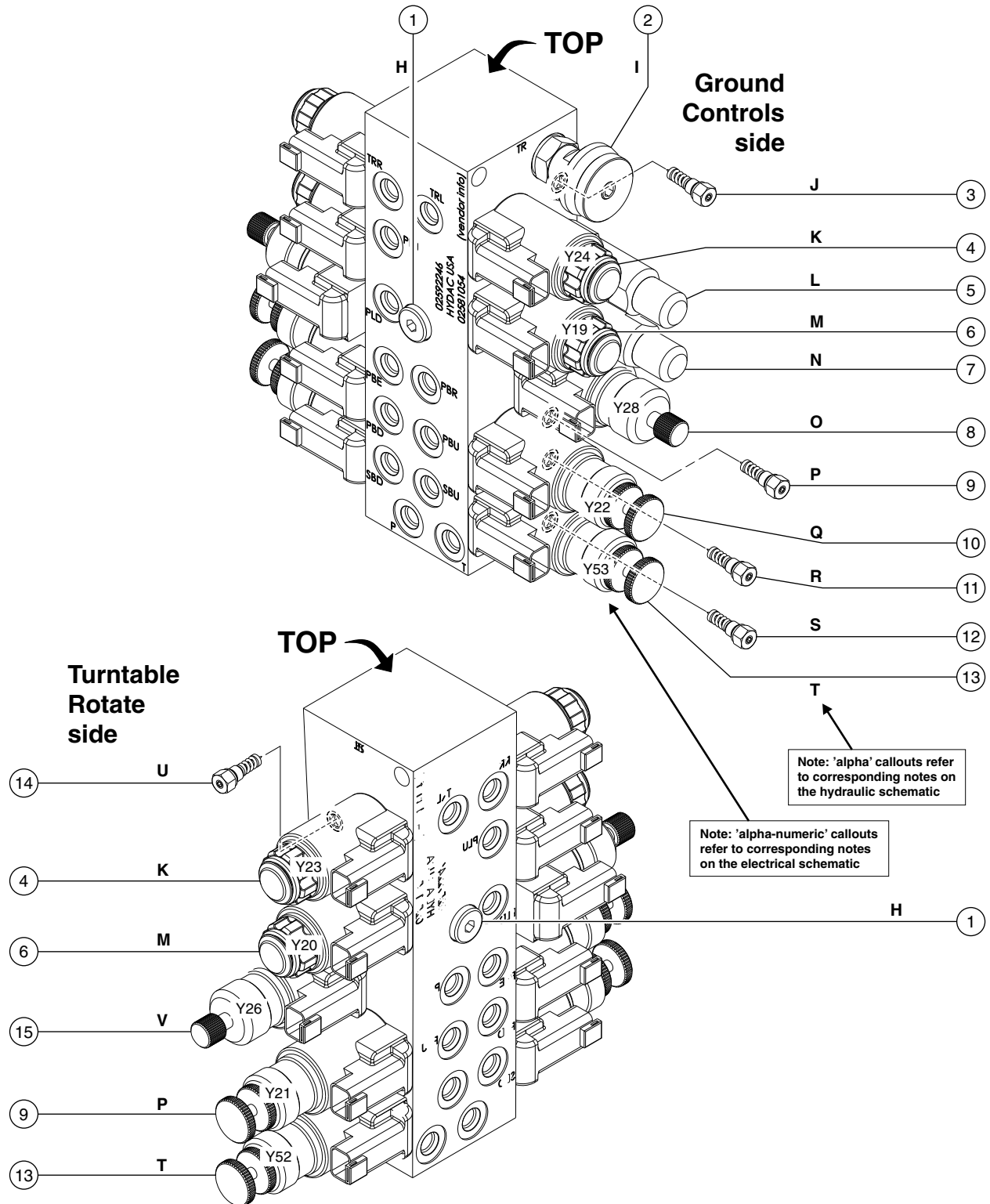

MANIFOLDS

6-2**Function Manifold Components
(from serial number TZ3403-249 to TZ3405-171)**

The function manifold is located under the turntable cover.

Index No.	Description	Schematic Item	Function	Torque
1	Flow regulator, 0.4 gpm / 1.5 L/min To serial number TZ3404-357	H	Platform level/turntable rotate circuit ...	7-8 ft-lbs / 9.5-10.5 Nm
	Flow regulator, 0.34 gpm / 1.3 L/min From to serial number TZ3404-358	H	Platform level/turntable rotate circuit ...	7-8 ft-lbs / 9.5-10.5 Nm
2	Relief valve, 1200 psi / 82.7 bar	J	Turntable rotate circuit	7-8 ft-lbs / 9.5-10.5 Nm
3	Solenoid valve, 3 position 4 way	K	Turntable rotate left/right	7-8 ft-lbs / 9.5-10.5 Nm
4	Counterbalance valve	L	Platform level up circuit	19-22 ft-lbs / 25-30 Nm
5	Solenoid valve, 3 position 4 way	M	Platform level	7-8 ft-lbs / 9.5-10.5 Nm
6	Counterbalance valve	N	Platform level down circuit	19-22 ft-lbs / 25-30 Nm
7	Solenoid valve, 2 position 3 way with manual override	O	Fluid regeneration, boom extend circuit	19-22 ft-lbs / 25-30 Nm
8	Relief valve, 1800 psi / 124.1 bar	P	Boom extend circuit	11-13 ft-lbs / 15-17 Nm
9	Solenoid valve, 3 position 4 way with manual override	Q	Primary boom up/down	7-8 ft-lbs / 9.5-10.5 Nm
10	Relief valve, 1600 psi / 110.3 bar	R	Primary boom circuit	11-13 ft-lbs / 15-17 Nm
11	Relief valve, 1100 psi / 75.8 bar	S	Secondary boom circuit	11-13 ft-lbs / 15-17 Nm
12	Solenoid valve, 3 position 4 way with manual override	T	Secondary boom up/down	7-8 ft-lbs / 9.5-10.5 Nm
13	Relief valve, 1200 psi / 82.7 bar	U	Turntable rotate circuit	11-13 ft-lbs / 15-17 Nm
14	Solenoid valve, 2 position 3 way with manual override	V	Boom extend/retract	19-22 ft-lbs / 25-30 Nm

MANIFOLDS

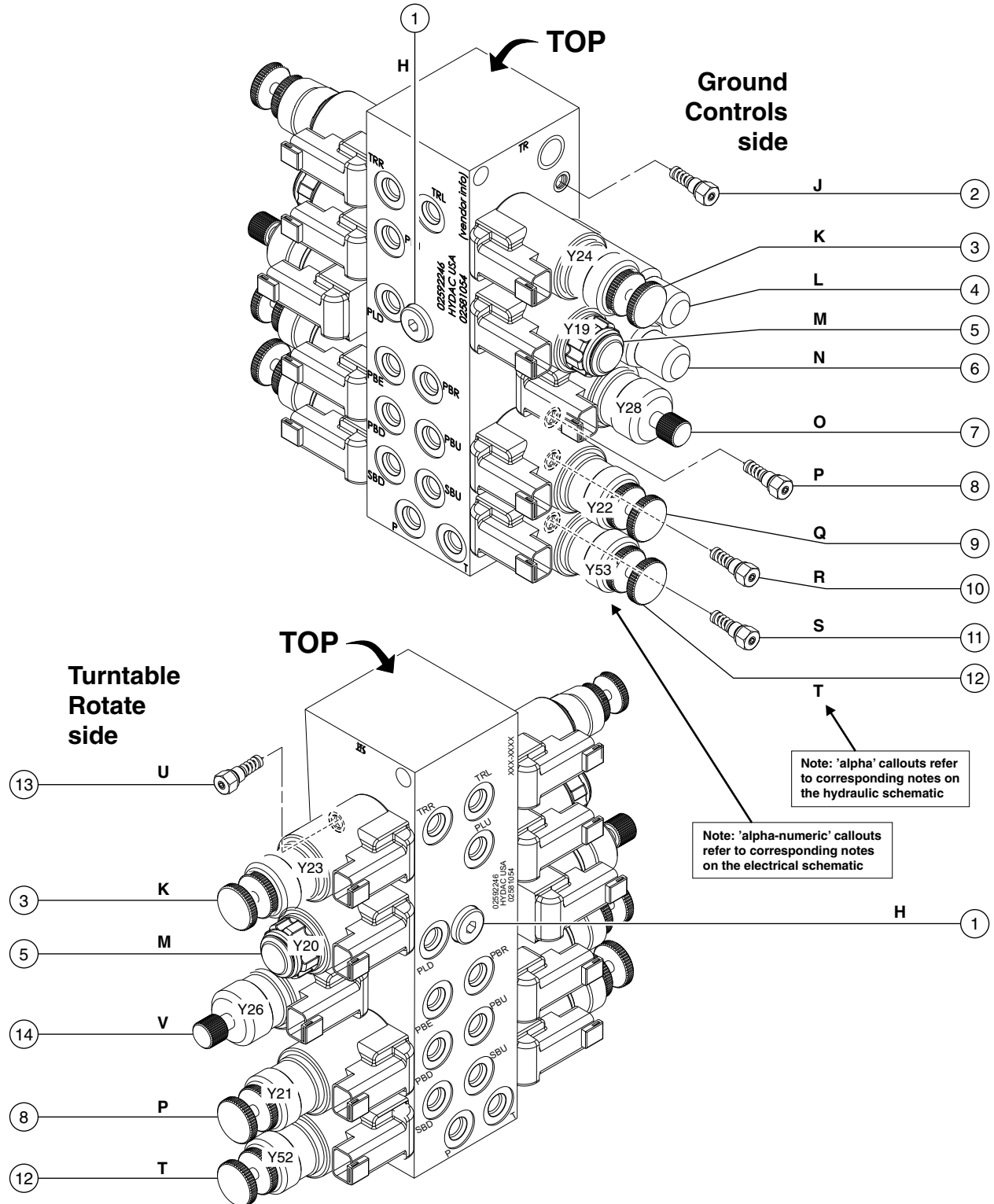

MANIFOLDS

6-3**Function Manifold Components
(from serial number TZ3405-172)**

The function manifold is located under the turntable cover.

Index No.	Description	Schematic Item	Function	Torque
1	Solenoid valve, 3 position 4 way with manual override	AA	Turntable rotate left/right	7-8 ft-lbs / 9.5-10.5 Nm
2	Solenoid valve, 3 position 4 way	AB	Platform level	7-8 ft-lbs / 9.5-10.5 Nm
3	Solenoid valve, 2 position 3 way with manual override	AC	Boom extend/retract	19-22 ft-lbs / 25-30 Nm
4	Solenoid valve, 3 position 4 way with manual override	AD	Primary boom up/down	7-8 ft-lbs / 9.5-10.5 Nm
5	Solenoid valve, 3 position 4 way with manual override	AE	Secondary boom up/down	7-8 ft-lbs / 9.5-10.5 Nm
6	Relief valve, 1200 psi / 82.7 bar	AF	Turntable rotate circuit	7-8 ft-lbs / 9.5-10.5 Nm
7	Counterbalance valve	AG	Platform level up circuit	19-22 ft-lbs / 25-30 Nm
8	Counterbalance valve	AH	Platform level down circuit	19-22 ft-lbs / 25-30 Nm
9	Relief valve, 1600 psi / 110.3 bar	AI	Primary boom circuit	11-13 ft-lbs / 15-17 Nm
10	Relief valve, 1100 psi / 75.8 bar	AJ	Secondary boom circuit	11-13 ft-lbs / 15-17 Nm
11	Relief valve, 1800 psi / 124.1 bar	AK	Boom extend circuit	11-13 ft-lbs / 15-17 Nm
12	Flow regulator, 0.4 gpm / 1.5 L/min	AL	Platform level/turntable rotate circuit ...	7-8 ft-lbs / 9.5-10.5 Nm
13	Relief valve, 1200 psi / 82.7 bar	AM	Turntable rotate circuit	11-13 ft-lbs / 15-17 Nm

MANIFOLDS

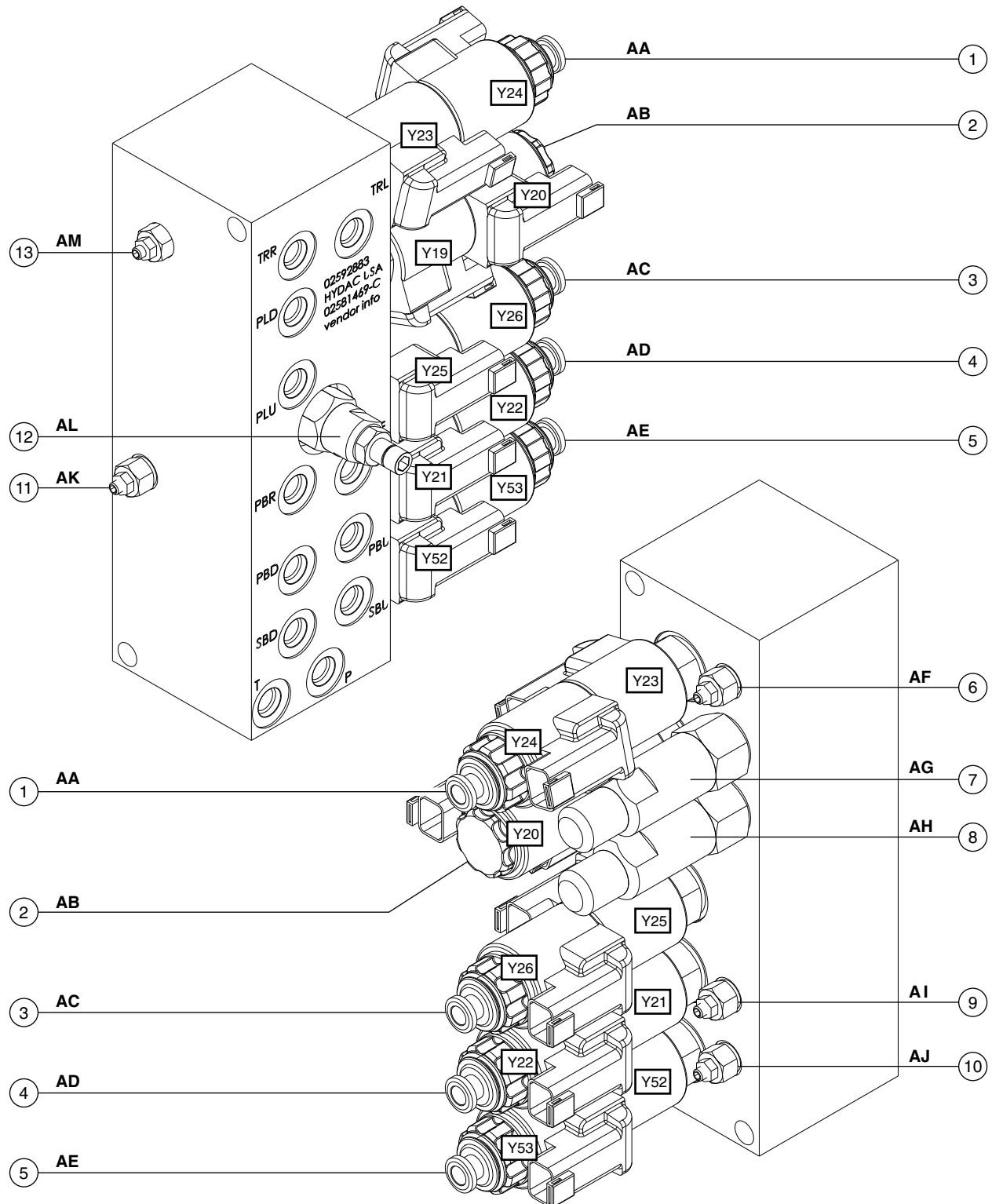

MANIFOLDS

6-4 Outrigger Counterbalance Valve Manifold Components (from serial number TZ3412-299)

The outrigger manifold is located under the hydraulic power unit cover.

Index No.	Description	Schematic Item	Function	Torque
1	Counterbalance valve	AN	Outrigger Retract	19-22 ft-lbs / 25-30 Nm
2	Counterbalance valve	AO	Outrigger Extend	19-22 ft-lbs / 25-30 Nm

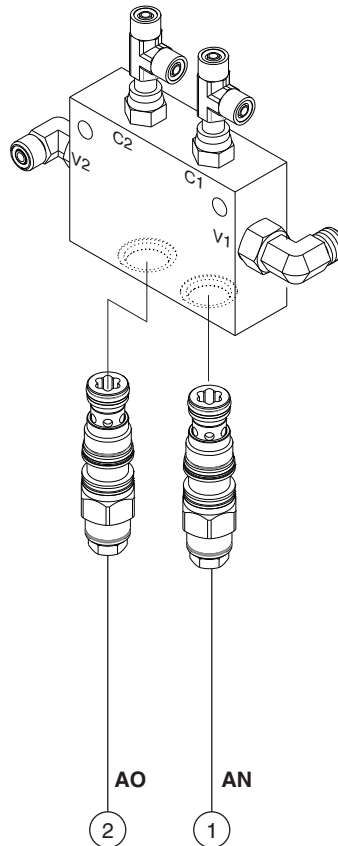

6-5 Valve Adjustments - Function Manifold

How to Adjust the Primary Boom Down Relief Valve

- 1 Connect a 0 to 3000 psi / 0 to 200 bar pressure gauge to the test port on the hydraulic power unit located in the chassis.
- 2 Turn the key switch to ground control and pull out the red Emergency Stop button to the on position.
- 3 Press and hold the yellow function enable button and press and hold the primary boom up/down button with the primary boom fully lowered. Observe the pressure reading on the pressure gauge. Refer to Specifications, *Hydraulic Specifications*.
- 4 Turn the machine off. Hold the relief valve stem with a hex key and loosen the jam nut (item AI).
- 5 Adjust the valve stem. Turn it clockwise to increase the pressure or counterclockwise to decrease the pressure. Tighten the jam nut.

▲WARNING Tip-over hazard. Do not adjust the relief valve higher than specified.

- 6 Repeat step 3 to confirm the relief valve pressure setting.

How to Adjust the Secondary Boom Down Relief Valve

- 1 Connect a 0 to 3000 psi / 0 to 200 bar pressure gauge to the test port on the hydraulic power unit located in the chassis.
- 2 Turn the key switch to ground control and pull out the red Emergency Stop button to the on position.
- 3 Press and hold the yellow function enable button and press and hold the secondary boom up/down button with the secondary boom fully lowered. Observe the pressure reading on the pressure gauge. Refer to Specifications, *Hydraulic Specifications*.
- 4 Turn the machine off. Hold the relief valve stem with a hex key and loosen the jam nut (item AJ).
- 5 Adjust the valve stem. Turn it clockwise to increase the pressure or counterclockwise to decrease the pressure. Tighten the jam nut.

▲WARNING Tip-over hazard. Do not adjust the relief valve higher than specified.

- 6 Repeat step 3 to confirm the relief valve pressure setting.

How to Adjust the Primary Boom Extend Relief Valve

- 1 Connect a 0 to 3000 psi / 0 to 200 bar pressure gauge to the test port on the hydraulic power unit located in the chassis.
- 2 Turn the key switch to ground control and pull out the red Emergency Stop button to the on position.
- 3 Fully lower the outriggers and level the machine.
- 4 Release the boom hold-down latches.
- 5 Raise the primary boom to the horizontal position.
- 6 Press and hold the blue function enable button and press and hold the primary boom extend/retract button and fully extend the boom. Continue holding both buttons and observe the pressure reading on the pressure gauge. Refer to Specifications, *Hydraulic Specifications*.
- 7 Turn the machine off. Hold the relief valve stem with a hex key and loosen the jam nut (item AK).
- 8 Adjust the valve stem. Turn it clockwise to increase the pressure or counterclockwise to decrease the pressure. Tighten the jam nut.

WARNING Tip-over hazard. Do not adjust the relief valve higher than specified.

- 9 Repeat step 6 to confirm the relief valve pressure setting.

How to Adjust the Turntable Rotate Relief Valves

- 1 Verify the boom is properly stowed and the hold-down latches are secured.
- 2 Connect a 0 to 3000 psi / 0 to 200 bar pressure gauge to the test port on the hydraulic power unit located in the chassis.
- 3 Turn the key switch to ground control and pull out the red Emergency Stop button to the on position.
- 4 Press and hold the yellow function enable button and press and hold the turntable rotate button. Observe the pressure reading on the pressure gauge. Refer to Specifications, *Hydraulic Specifications*.
- 5 Turn the machine off. Hold the relief valve stem with a hex key and loosen the jam nut (item AF).
- 6 Adjust the valve stem. Turn it clockwise to increase the pressure or counterclockwise to decrease the pressure. Tighten the jam nut.

WARNING Tip-over hazard. Do not adjust the relief valve higher than specified.

- 7 Repeat step 4 to confirm the relief valve pressure setting.
- 8 Turn the key switch to ground control and pull out the red Emergency Stop button to the on position.

- 9 Press and hold the blue function enable button and press and hold the turntable rotate button. Observe the pressure reading on the pressure gauge. Refer to Specifications, *Hydraulic Specifications*.
- 10 Turn the machine off. Hold the relief valve stem with a hex key and loosen the jam nut (item AM).
- 11 Adjust the valve stem. Turn it clockwise to increase the pressure or counterclockwise to decrease the pressure. Tighten the jam nut.

⚠WARNING Tip-over hazard. Do not adjust the relief valve higher than specified.

- 12 Repeat steps 8 and 9 to confirm the relief valve pressure setting.

6-6 Valve Coils

How to Test a Coil

A properly functioning coil provides an electromotive force which operates the solenoid valve. Critical to normal operation is continuity within the coil that provides this force field.

⚠ WARNING Electrocutation hazard. Contact with electrically charged circuits could result in death or serious injury. Remove all rings, watches and other jewelry.

- 1 Tag and disconnect the wire harness from the coil to be tested.
 - 2 Test the coil resistance.
- ⊕ Result: The resistance should be within specification, plus or minus 30%.
- ⊗ Result: If the resistance is not within specification, plus or minus 30%, replace the coil.

Valve Coil Resistance

Description	Specification
Solenoid valve, 3 position 4 way 24V DC with diode (schematic item B, AA, AB, AC, AD and AE)	29 to 31Ω
Solenoid valve, 3 position 4 way 24V DC with diode (schematic items K, M, Q and T)	20 to 22Ω
Solenoid valve, 2 position 3 way 24V DC with diode (schematic items O and V)	29 to 31Ω
Solenoid valve, 2 position 2 way, N.C. 24V DC with diode (schematic items W, X, Y and Z)	29 to 31Ω

How to Test a Coil Diode

Genie incorporates spike-suppressing diodes in all of its coils. Properly functioning coil diodes protect the electrical circuit by suppressing voltage spikes. Voltage spikes naturally occur within a function circuit following the interruption of electrical current to a coil. Faulty diodes can fail to protect the electrical system, resulting in a tripped circuit breaker or component damage.

⚠ WARNING Electrocutation hazard. Contact with electrically charged circuits could result in death or serious injury. Remove all rings, watches and other jewelry.

- 1 Test the coil for resistance. See 6-5, *How to Test a Coil*.

MANIFOLDS

- 2 Connect a 10Ω resistor to the negative terminal of a known good 9V DC battery. Connect the other end of the resistor to a terminal on the coil.

Note: The battery should read 9V DC or more when measured across the terminals.

Resistor, 10Ω

Genie part number

27287

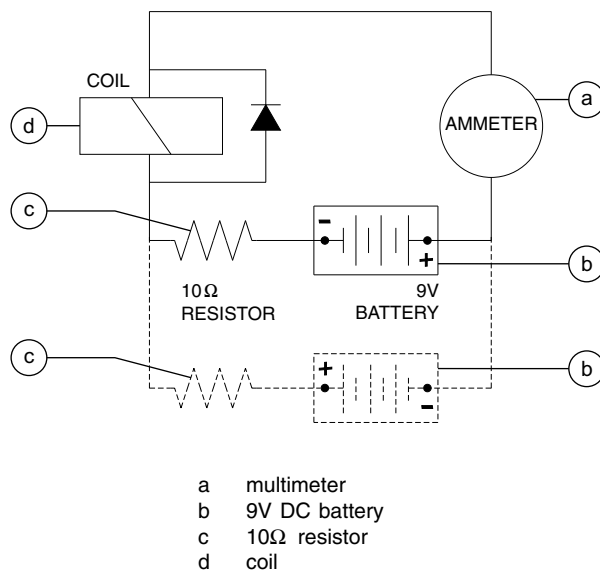

Note: Dotted lines in illustration indicate a reversed connection as specified in step 6

- 3 Set a multimeter to read DC amperage.

Note: The multimeter, when set to read DC amperage, should be capable of reading up to 800 mA.

- 4 Connect the negative lead to the other terminal on the coil.

Note: If testing a single-terminal coil, connect the negative lead to the internal metallic ring at either end of the coil.

- 5 Momentarily connect the positive lead from the multimeter to the positive terminal on the 9V battery. Note and record the current reading.

- 6 At the battery or coil terminals, reverse the connections. Note and record the current reading.

☉ Result: Both current readings are greater than 0 mA and are different by a minimum of 20%. The coil is good.

☒ Result: If one or both of the current readings are 0 mA, or if the two current readings do not differ by a minimum of 20%, the coil and/or its internal diode are faulty and the coil should be replaced.

Turntable Rotation Components

7-1

Turntable Rotation Motor

How to Remove the Turntable Rotation Motor

Note: When removing a hose assembly or fitting, the O-ring on the fitting and/or hose end must be replaced and then torqued to specification during installation. Refer to Section 2, *Hydraulic Hose and Fitting Torque Specifications*.

- 1 Secure the primary boom to the turntable with the hold-down latch.

NOTICE The hold-down latch is located at the platform end of the primary boom.

- 2 Remove the cover support (if equipped).
- 3 Tag, disconnect and plug the hydraulic hoses. Cap the fittings on the turntable rotation motor.

⚠WARNING Bodily injury hazard. Spraying hydraulic oil can penetrate and burn skin. Loosen hydraulic connections very slowly to allow the oil pressure to dissipate gradually. Do not allow oil to squirt or spray.

- 4 Remove the turntable rotation motor mounting fasteners and remove the turntable rotation motor from the machine.

Axle Components

8-1 Axle

How to Remove the Axle

ANSI/CSA/AS models:

- 1 Lower the outriggers and adjust to level the machine and raise the wheels off the ground.
- 2 Disconnect the parking brake cable at the parking brake handle.
- 3 Pull the cables free of the trailer.
- 4 Tag, disconnect and plug the brake line from the back of the hub. Cap the fitting.
- 5 Clean up any brake fluid that may have spilled.
- 6 Repeat steps 4 through 5 for the other side.
- 7 Support and secure the axle assembly to an appropriate lifting device.
- 8 Remove the axle mounting fasteners and remove the axle from the machine.

WARNING Crushing hazard. The axle could become unbalanced and fall if not properly supported and secured when removed from the machine.

NOTICE When the axle is installed, the brakes should be bled. Refer to the appropriate brake manufacturer's manual that was shipped with your Genie TZ.

CE models:

- 1 Lower the outriggers and adjust to level the machine and raise the wheels off the ground.
- 2 Disconnect the parking brake cable at the tension equalizer.
- 3 Support and secure the axle assembly to an appropriate lifting device.
- 4 Remove the axle mounting fasteners and remove the axle from the machine.

WARNING Crushing hazard. The axle could become unbalanced and fall if not properly supported and secured when removed from the machine.

Trailer Components

9-1 Hydraulic and Mechanical Brakes

Hydraulic Brake System - ANSI Models

Repair procedures and additional axle information is available in the *Dexter Axle Operation Maintenance Service Manual*

(Dexter part number LIT-001-00).

Dexter Axle Operation Maintenance Service Manual
Genie part number 84376

Mechanical Brake System - CE Models

Repair procedures and additional axle information is available in the *KNOTT Axle Service Manual* (KNOTT part number P005).

KNOTT Axle Service Manual
Genie part number 84443

9-2 Parking Brake

How to Adjust the Parking Brake

ANSI models:

- 1 Adjust the brakes. Refer to the *Dexter Axle Operation Maintenance Service Manual* (Dexter part number LIT-001-00).

Dexter Axle Operation Maintenance Service Manual
Genie part number 84376

- 2 Chock the wheels.
 - 3 Release the parking brake.
 - 4 Loosen the set screw at the side of the parking brake handle.
 - 5 Adjust the handle just to the point where it is difficult to apply the parking brake, then rotate the top of the parking brake handle counterclockwise one full turn.
 - 6 Tighten the set screw. Do not over tighten.
 - 7 Engage the parking brake. Attempt to move the machine.
- ⊙ Result: The parking brake should prevent the machine from moving. If the parking brake does not prevent the machine from moving, repeat this procedure beginning with step 1.

CE models:

Required maintenance procedures and additional axle information is available in the *KNOTT Axle Service Manual* (KNOTT part number P005).

KNOTT Axle Service Manual
Genie part number 84443

Outriggers

10-1 Outrigger Components

How to Remove an Outrigger

Outriggers are essential to safe machine operation and machine stability. Operating a machine with a damaged or improperly operating outrigger will result in death or serious injury.

Note: Perform this procedure with the machine disconnected from the tow vehicle and the parking brake applied.

Note: Perform this procedure with the outriggers in the stowed position.

- 1 Attach a lifting strap of suitable capacity from an overhead crane to the pad end of the outrigger. Do not apply any lifting pressure.
- 2 Tag and disconnect the wire harness from the outrigger valve coil.
- 3 Tag, disconnect and plug the hydraulic hoses at the outrigger cylinder. Cap the fittings.
- 4 Remove the pin retaining fasteners from the outrigger pivot pin. Do not remove the pin.
- 5 Remove the pin retaining fasteners from the outrigger cylinder barrel-end pivot pin.
- 6 Place a rod through the hole in the outrigger cylinder barrel-end pivot pin and twist to remove the pin. Remove the pivot pin from the machine.

▲WARNING Crushing hazard. The outrigger could fall if not properly supported when the pivot pin is removed from the machine.

- 7 Place a rod through the hole in the outrigger pivot pin and twist to remove the pin. Remove the outrigger pivot pin from the machine.

▲WARNING Crushing hazard. The outrigger will fall if not properly supported when the pivot pin is removed from the machine.

- 8 Remove the outrigger and cylinder from the machine.

OUTRIGGERS

10-2 Outrigger Cylinder

How to Remove an Outrigger Cylinder

Note: When removing a hose assembly or fitting, the O-ring on the fitting and/or hose end must be replaced and then torqued to specification during installation. Refer to Section 2, *Hydraulic Hose and Fitting Torque Specifications*.

- 1 Extend the outrigger until the pad just touches the ground. Do not rest the weight of the machine on the outrigger.
- 2 Remove the hose guard mounting fasteners from the rod end of the outrigger cylinder and remove the hose guard from the machine.
- 3 Tag, disconnect and plug the hydraulic hoses from the outrigger cylinder. Cap the fittings on the cylinder.

▲WARNING Bodily injury hazard. Spraying hydraulic oil can penetrate and burn skin. Loosen hydraulic connections very slowly to allow the oil pressure to dissipate gradually. Do not allow oil to squirt or spray.

- 4 Tag and disconnect the wire harness from the outrigger cylinder valve coil.

- 5 Attach a lifting strap from an overhead crane to the lug on the rod end of the cylinder.
- 6 Remove the pin retaining fasteners from the outrigger cylinder rod-end pivot pin.
- 7 Place a rod through the hole in the outrigger cylinder rod-end pivot pin and twist to remove the pin. Remove the outrigger cylinder rod-end pivot pin from the machine.
- 8 Raise the cylinder to a vertical position.
- 9 Remove the pin retaining fasteners from the outrigger cylinder barrel-end pivot pin.
- 10 Place a rod through the hole in the outrigger cylinder barrel-end pivot pin and twist to remove the pin. Remove the outrigger cylinder barrel-end pivot pin from the machine.

▲WARNING Crushing hazard. The outrigger cylinder could fall if not properly supported when the pivot pin is removed from the machine.

▲CAUTION Component damage hazard. The solenoid valve can be damaged. Use caution when removing the cylinder from the machine.

Platform Overload Components

11-1

Platform Overload System

Calibrate the Platform Overload System (if equipped)

Note: Perform this procedure with the machine on a firm, level surface.

- 1 At the ground controls, extend the outriggers until the tires are off the ground and the machine is level.
- 2 Release the boom hold down latch and raise the platform approximately 2 feet / 70 cm. Level the platform.
- 3 Tag and disconnect the wire harness from the load sense limit switch.

Note: The load sense limit switch is located near the platform support.

- 4 Set a multi-meter to measure continuity. Connect the leads from the multi-meter to the black and red wires disconnected from the limit switch in step 3.
- 5 Determine the maximum platform capacity. Refer to the machine serial plate.
- 6 Using a suitable lifting device, place an appropriate test weight equal to that of the maximum platform capacity at the center of the platform floor.

Determine the limit switch trigger point:

- 7 Gently move the platform up and down by hand, so it bounces 1 to 2 inches / 2.5 to 5 cm.
- 8 Check the continuity between the black and red wires originating from the limit switch of the platform overload assembly.
 - ⦿ Result: **There is no continuity.** Slowly tighten the load spring adjustment nut by turning it clockwise just until the limit switch closes and shows continuity.
 - ⦿ Result: **There is continuity.** Slowly loosen the load spring adjustment nut by turning it counterclockwise just until the limit switch opens and shows no continuity.

Note: The platform will need to be continuously moved up and down while making adjustments.

Fine adjustment of the switch trigger point:

- 9 Continue moving the platform up and down and adjust the load spring adjustment nut clockwise or counterclockwise just until the limit switch is alternately opening and closing.

Note: When the limit switch is adjusted correctly, there will be continuity slightly longer than no continuity.

- 10 Remove the continuity tester from the limit switch wires. Securely install the wires onto the limit switch.

PLATFORM OVERLOAD COMPONENTS

Confirm the setting:

- 11 Turn the key switch to platform control.
- 12 Lift the test weight off the platform floor using a suitable lifting device.
- 13 Place the test weight back onto the platform floor using a suitable lifting device.
- ⦿ Result: The platform overload indicator light should be off at both the ground and platform controls.
- 14 Add an additional 44 lbs / 20 kg of weight to overload the platform.
- ⦿ Result: The platform overload indicator light should be flashing at both the ground and platform controls.
- 15 Test all machine functions from the platform controls.
- ⦿ Result: All platform control functions should not operate.
- 16 Turn the key switch to ground control.
- 17 Test all machine functions from the ground controls.
- ⦿ Result: All ground control functions should not operate.

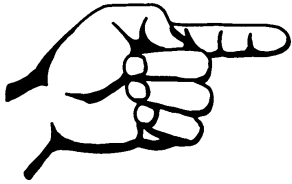

This page intentionally left blank.

Schematics



Observe and Obey:

- ☑ Troubleshooting and repair procedures shall be completed by a person trained and qualified on the repair of this machine.
- ☑ Immediately tag and remove from service a damaged or malfunctioning machine.
- ☑ Repair any machine damage or malfunction before operating the machine.

Before Troubleshooting:

- ☑ Read, understand and obey the safety rules and operating instructions in the appropriate Operator's Manual on your machine before attempting any maintenance or repair procedure.
- ☑ Be sure that all necessary tools and test equipment are available and ready for use.

About This Section

There are two groups of schematics in this section. An illustration legend precedes each group of drawings.

Electrical Schematics

⚠WARNING Electrocutation hazard. Contact with electrically charged circuits could result in death or serious injury. Remove all rings, watches and other jewelry.

Hydraulic Schematics

⚠WARNING Bodily injury hazard. Spraying hydraulic oil can penetrate and burn skin. Loosen hydraulic connections very slowly to allow the oil pressure to dissipate gradually. Do not allow oil to squirt or spray.

General Repair Process

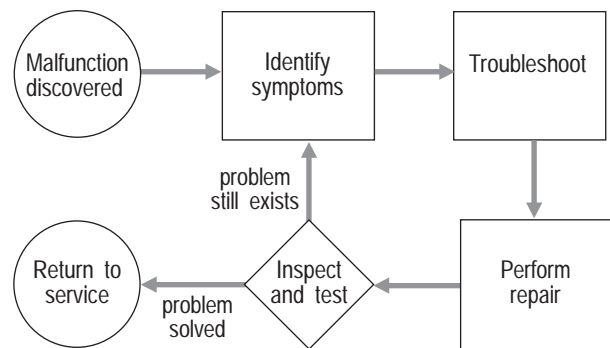

Electrical Abbreviations Legend

Item	Description
B	Battery
B5	Battery
BN	Button
BN49	Outrigger auto level
BN50	Left rear outrigger
BN51	Right rear outrigger
BN52	Left front outrigger
BN53	Right front outrigger
BN54	Primary boom up/down
BN55	Secondary boom up/down
BN56	Boom extend/retract
BN57	Turntable rotate
BN58	Platform level up/down
BN59	Function enable (boom down, boom retract, rotate left, outrigger extend)
BN60	Function enable (boom up, boom extend, rotate right, outrigger retract)
BN61	Function enable (boom down, boom retract, turntable/platform rotate left)
BN62	Function enable (boom up, boom extend, turntable/platform rotate right)
BN63	Primary boom up/down
BN64	Secondary boom up/down
BN65	Boom extend/retract
BN66	Turntable rotate
BN67	Platform level up/down

Item	Description
C	Capacitor
C4	Zener diode, 5.1V DC
C4A	Zener diode, 3.3V DC
C4A	Zener diode, 4.3V DC
C4B	Zener diode, 5.1V DC
C5	4700uF
CB	Circuit Breaker
CB2	Controls, 15A
CR	Control Relay
CR28	Power supply
CR55	Load Sense
CR61	Auto level system
CR64	Fault ground
CR65	Motor controller cutout
CR66	Level sensor (auto level)
CR67	Primary boom
CR68	Secondary boom
CR69	Boom extend/retract
CR70	Turntable rotate

Electrical Abbreviations Legend

Item	Description
CR	Control Relay
CR71	Platform level
CR72	Outrigger
CR73	Function enable (ground controls)
CR74	Function enable (platform controls)
CR75	Level sensor
CR76	Limit switch fault
CR77	Down enable
CR78	Lift cut-out
F	Fuse
F6	Function, 275A
FB1	Flashing Beacons (option)
GND	Ground
G	Gauge
G6	Hour meter
G7	Battery charge indicator (option)
H	Horn or Alarm
H1	Horn
H5	Multifunction alarm
KS1	Keyswitch

Item	Description
L	Light or LED
L4	Load sense at ground (load sense option)
L4A	Load sense at platform (load sense option)
L12	Left front outrigger
L13	Right front outrigger
L14	Left rear outrigger
L15	Right rear outrigger
L33	Right rear tail light
L34	Left rear tail light
L35	Right side marker
L36	Left side marker
LS	Limit Switch
LS12	Left front outrigger
LS13	Right front outrigger
LS14	Left rear outrigger
LS15	Right rear outrigger
LS18	Boom down
LS18A	Boom down
LS19	Load sense
M	Motor
M5	Hydraulic power unit
N.C.	Normally closed
NCHO	Normally closed, held open
N.O.	Normally Open
NOHC	Normally open, held closed
P	Power switch
P1	Emergency Stop button at ground controls
P2	Emergency Stop button at plat. controls

Electrical Abbreviations and Wire Color Legends

Item	Description
R	Resistor
R14	Function speed, 0-10K ohms
R16	2000 ohm
R20	10000 ohm
R22	4300 ohm
R22A	5600 ohm
S	Sensor
S7	Level sensor
S9	Level sensor, front/rear axis (auto level)
S10	Level sensor, left/right axis (auto level)
U	Electronic Component
U6	Motor controller
U9	Battery charger
U16	Time delay
U35	Time delay relay
Y	Valve Coil
Y19	Platform down
Y20	Platform up
Y21	Primary down
Y22	Primary up
Y23	Turntable rotate left
Y24	Turntable rotate right
Y25	Boom retract
Y26	Boom extend
Y33	Left rear outrigger
Y34	Right rear outrigger
Y35	Left front outrigger
Y36	Right front outrigger
Y39	Outrigger retract
Y40	Outrigger extend
Y52	Secondary down
Y53	Secondary up





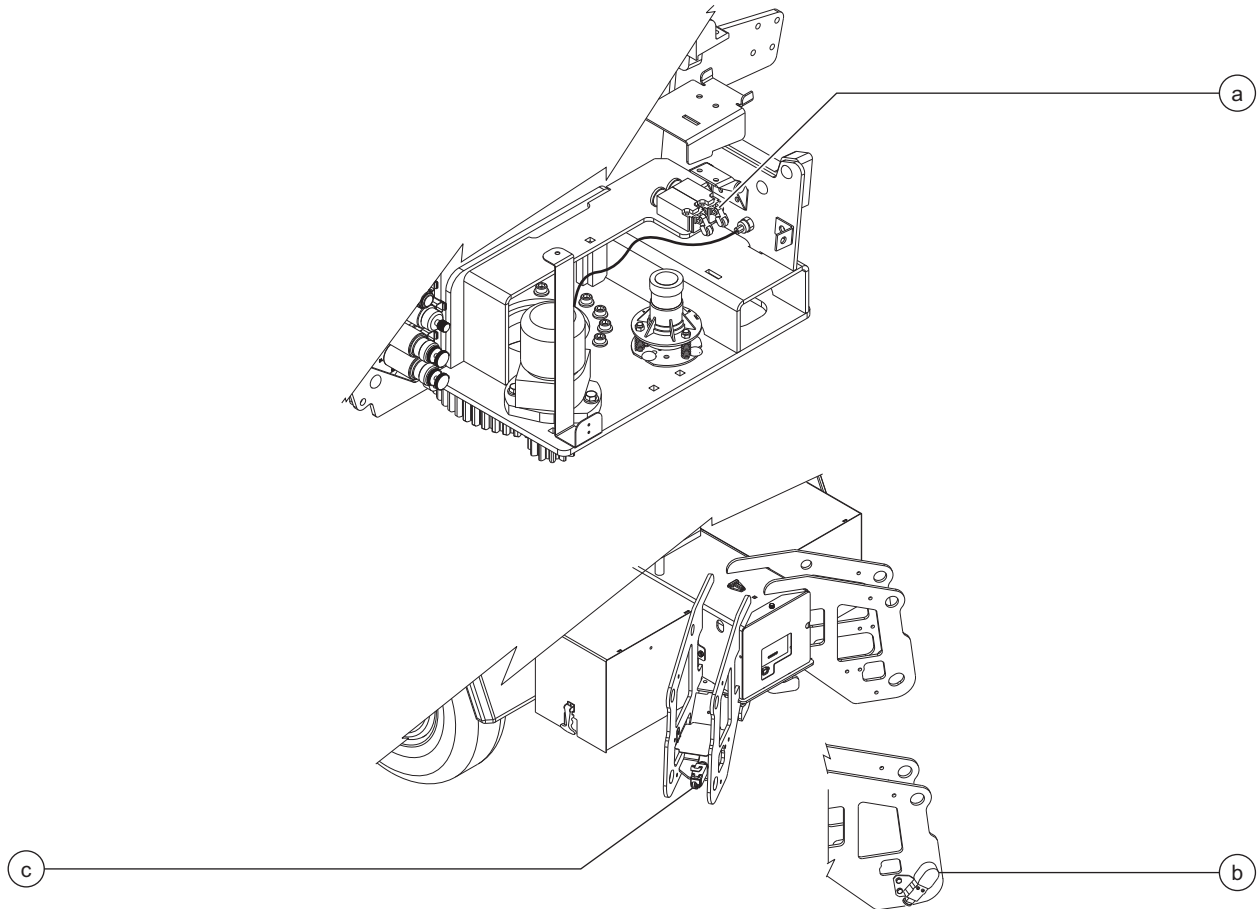





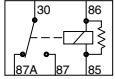

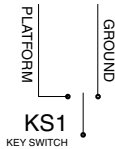

Wire Color Legend	
Item	Description
BL	Blue
BK	Black
GN	Green
OR	Orange
RD	Red
WH	White
BL/BK	Blue / Black
BL/WH	Blue / White
BK/RD	Black / Red
BK/WH	Black / White
GN/BK	Green / Black
GN/WH	Green / White
OR/BK	Orange / Black
OR/RD	Orange / Red
OR/WH	Orange / White
RD/BK	Red / Black
RD/WH	Red / White
WH/BK	White / Black
WH/RD	White / Red

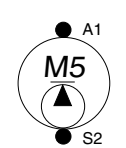
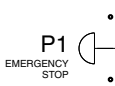
Limit Switch Legend

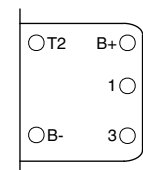
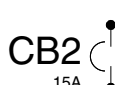

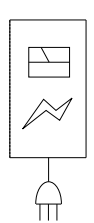
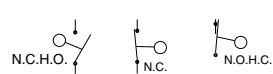
Item	Description	Schematic
a	Boom limit switches	LS18 / LS18A
b	Outrigger limit switches	LS12/LS13/LS14/LS15 from TZ3406-205
c	Outrigger limit switches	LS12/LS13/LS14/LS15 to TZ3406-204

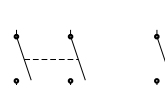
Electrical Symbols Legend

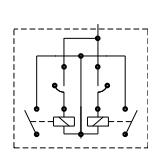
 TB1 Terminal	 Control relay	 6V Battery
 Diode	 Resistor	 Fuse
 Key switch	 LED	 Power unit or motor
 Emergency stop button, normally closed	 Hour meter	 Motor controller
 Circuit breaker	 Alarm	 Battery charger
 Limit switch	 Solenoid valve with diode	
 Toggle switch	 Quick disconnect	 Level sensor

Hydraulic Abbreviations Legend

Item	Description
A	Test port
B	Outrigger extend/retract
C	Check valve - outrigger circuit
D	Relief valve - outrigger circuit
E	System relief
F	Check valve - auxiliary pump
G	Sight gauge
H	Priority flow regulator, adjustable
I	Flow control - turntable rotate circuit
J	Relief valve - turntable rotate circuit
K	Turntable rotate left/right
L	Platform level counterbalance
M	Platform level up/down
N	Platform level counterbalance
O	Fluid regeneration - boom extend/retract
P	Relief valve - boom extend/retract
Q	Primary boom up/down
R	Relief valve - primary boom
S	Relief valve - secondary boom
T	Secondary boom up/down
U	Relief valve - turntable rotate circuit
V	Boom extend/retract

Item	Description
W	Outrigger retract - left rear
X	Outrigger retract - right rear
Y	Outrigger retract - left front
Z	Outrigger retract - right front
AA	Turntable rotate left/right
AB	Platform level up/down
AC	Boom extend/retract
AD	Primary boom up/down
AE	Secondary boom up/down
AF	Relief valve - turntable rotate circuit
AG	Platform level counterbalance
AH	Platform level counterbalance
AI	Relief valve - primary boom
AJ	Relief valve - secondary boom
AK	Relief valve - boom extend/retract
AL	Priority flow regulator, adjustable
AM	Relief valve - turntable rotate circuit

Hydraulic Symbols Legend



Variable speed motor

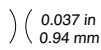

Orifice with size

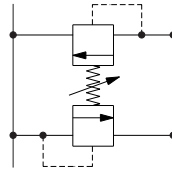

Relief valve

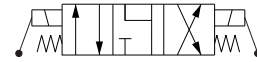

Solenoid operated 3 position 4 way directional valve with manual over ride



Fixed displacement pump

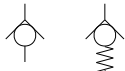

Check valve

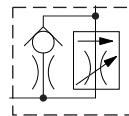

Pressure compensated priority flow regulator

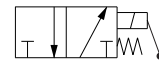

Solenoid operated 2 position 3 way directional valve with manual over ride

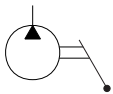

Fixed displacement hand pump



Check valve, pilot to open

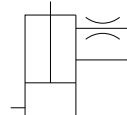

Double acting cylinder with cushion

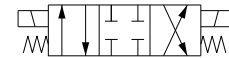

Solenoid operated 3 position 4 way directional valve



Bi-directional motor



Filter

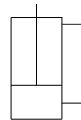

Double acting cylinder

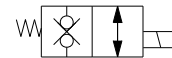

Solenoid operated 2 position 3 way directional valve

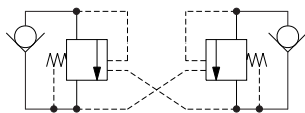

Counterbalance valve

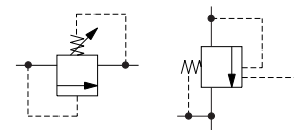

Relief valve

Trailer Lighting Wiring Diagram - ANSI/CSA

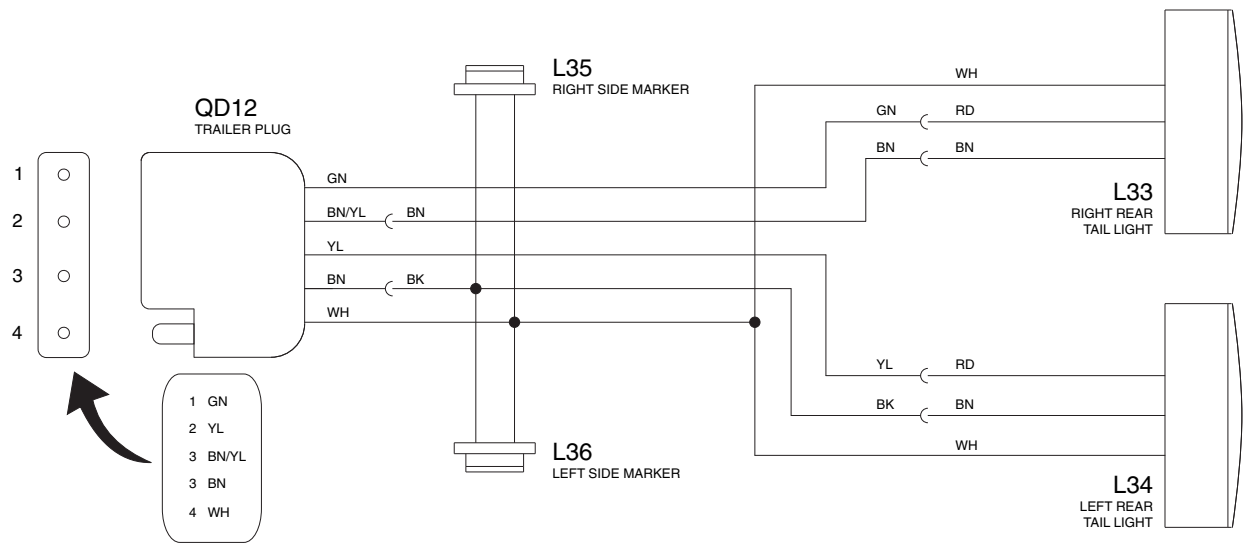

Trailer Lighting Wiring Diagram - Mechanical Axle, CE (to SN TZ3412-193)

Trailer Chassis Wiring Harness

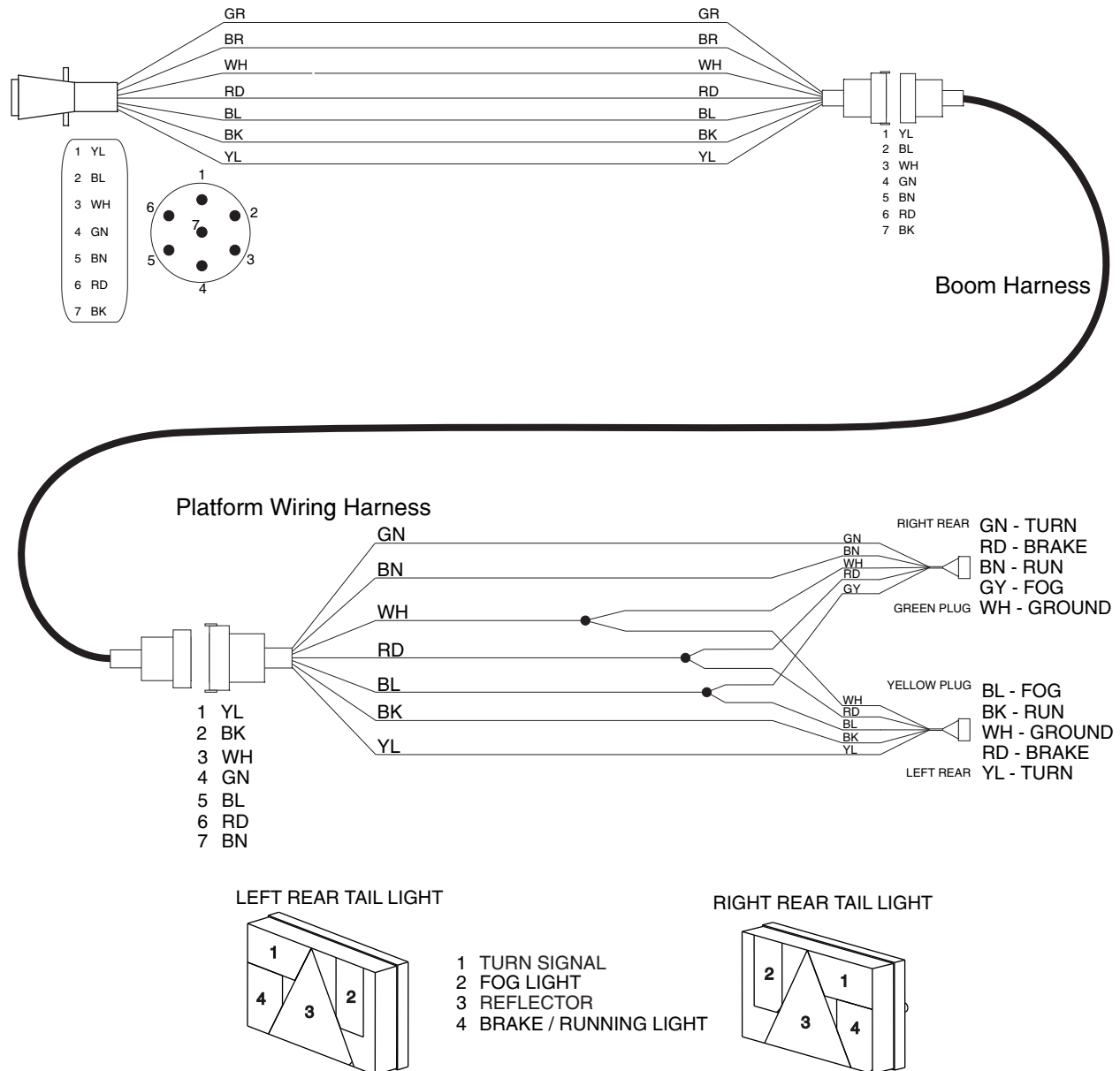

Trailer Lighting Wiring Diagram - Mechanical Axle, CE (from SN TZ3412-194)

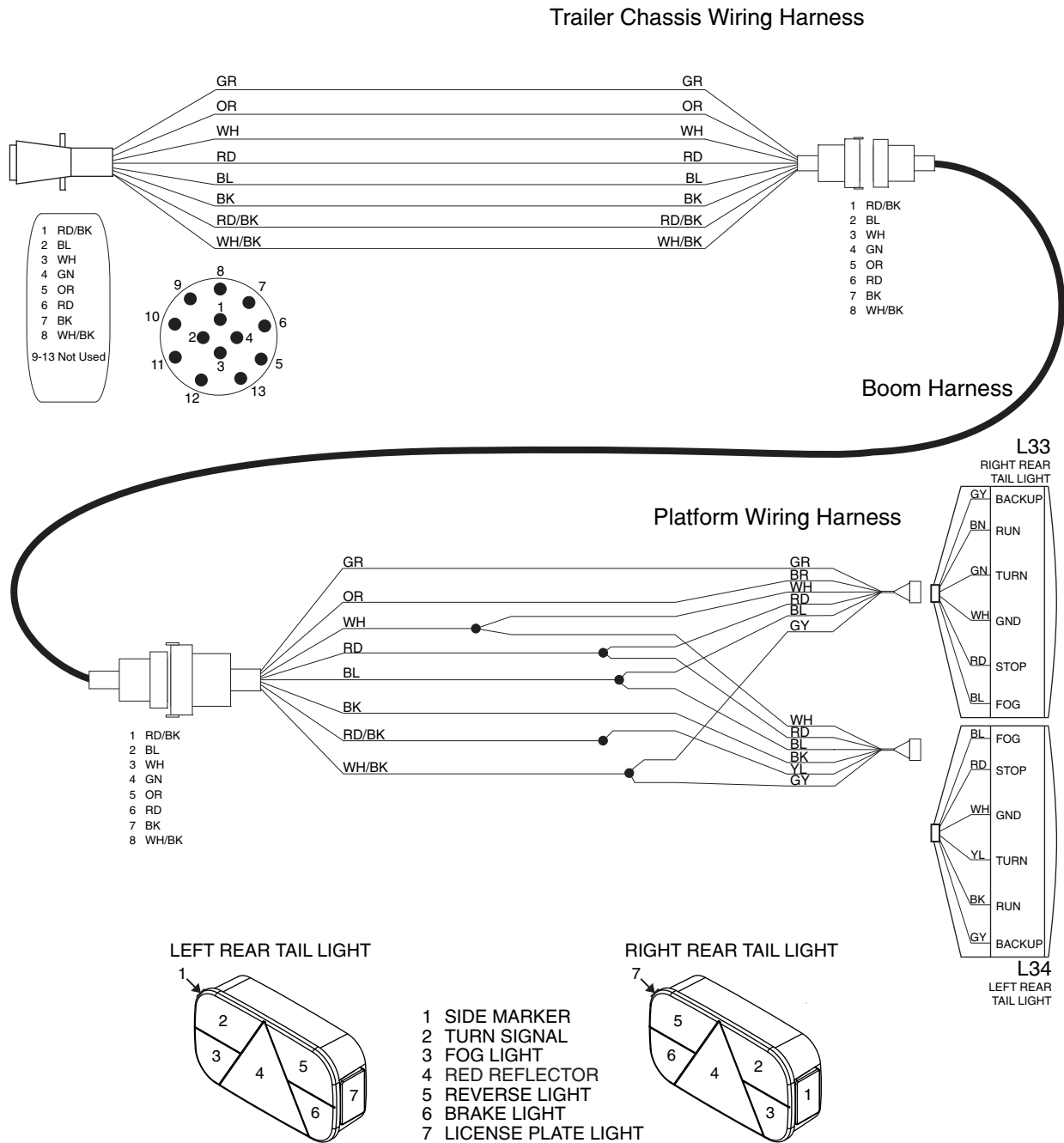

Trailer Lighting Wiring Diagram - Hydraulic Axle, AS (from SN TZ3412-193)

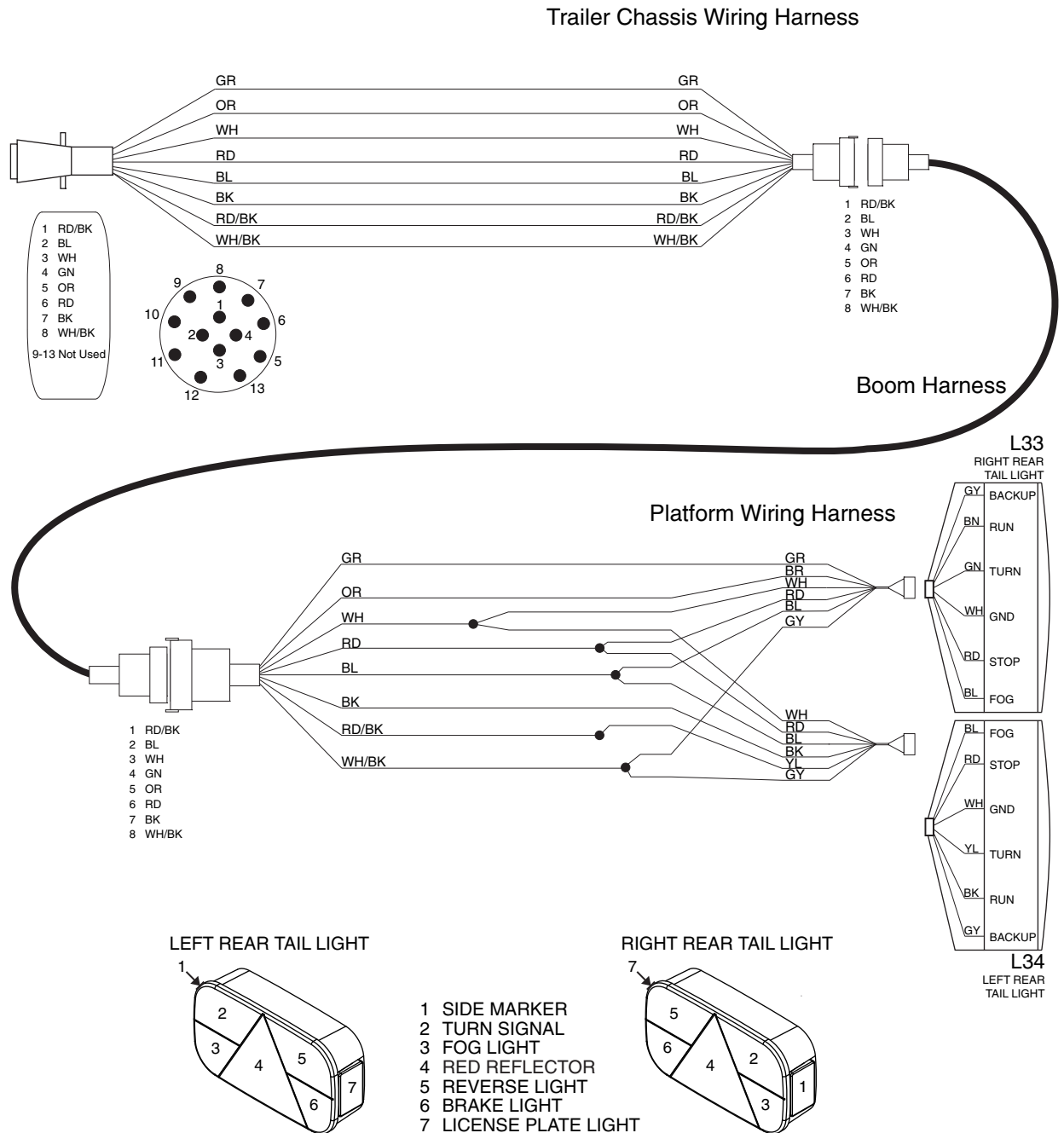

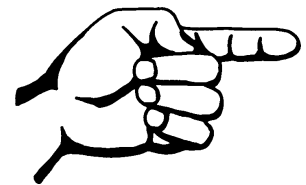

This page intentionally left blank.

Ground Control Box Wiring Diagram - ANSI/CSA (to serial number TZ3403-185)

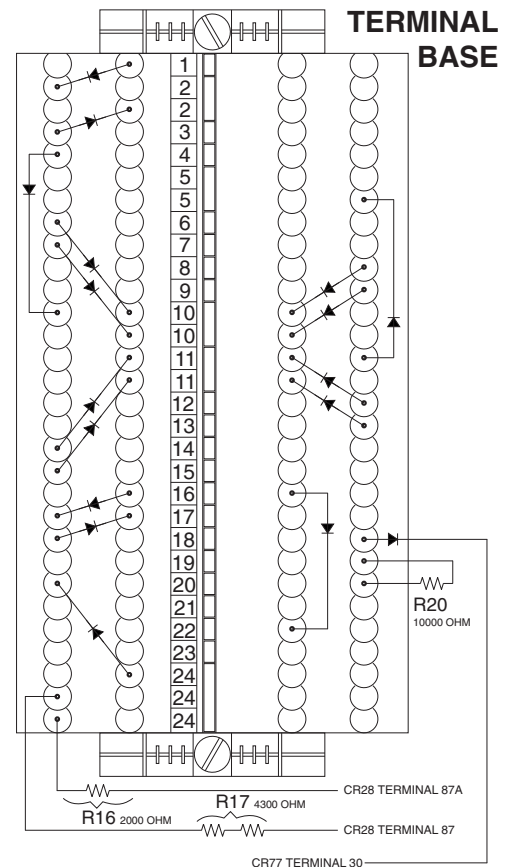
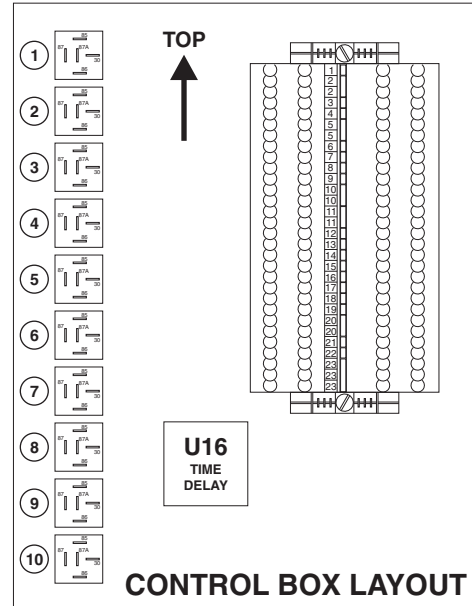
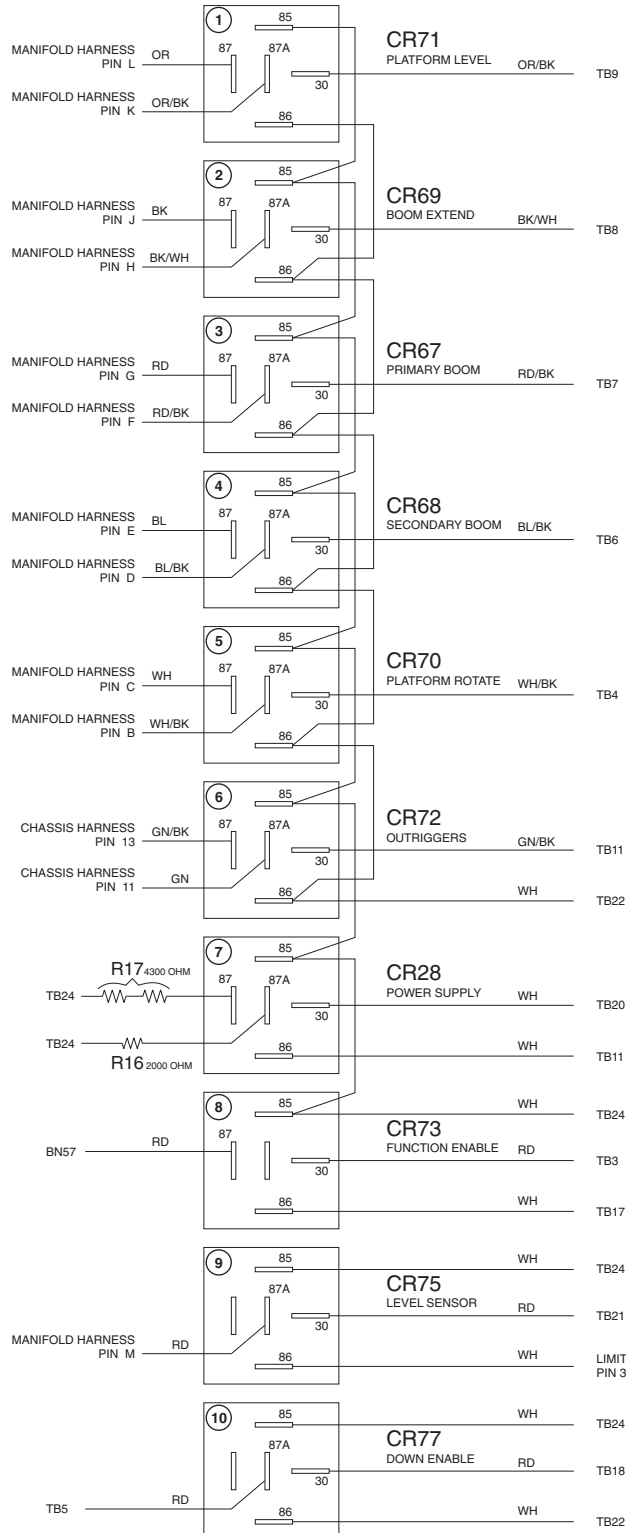

Ground Control Box Wiring Diagram - ANSI/CSA

(from serial number TZ3403-186 to TZ3403-248)

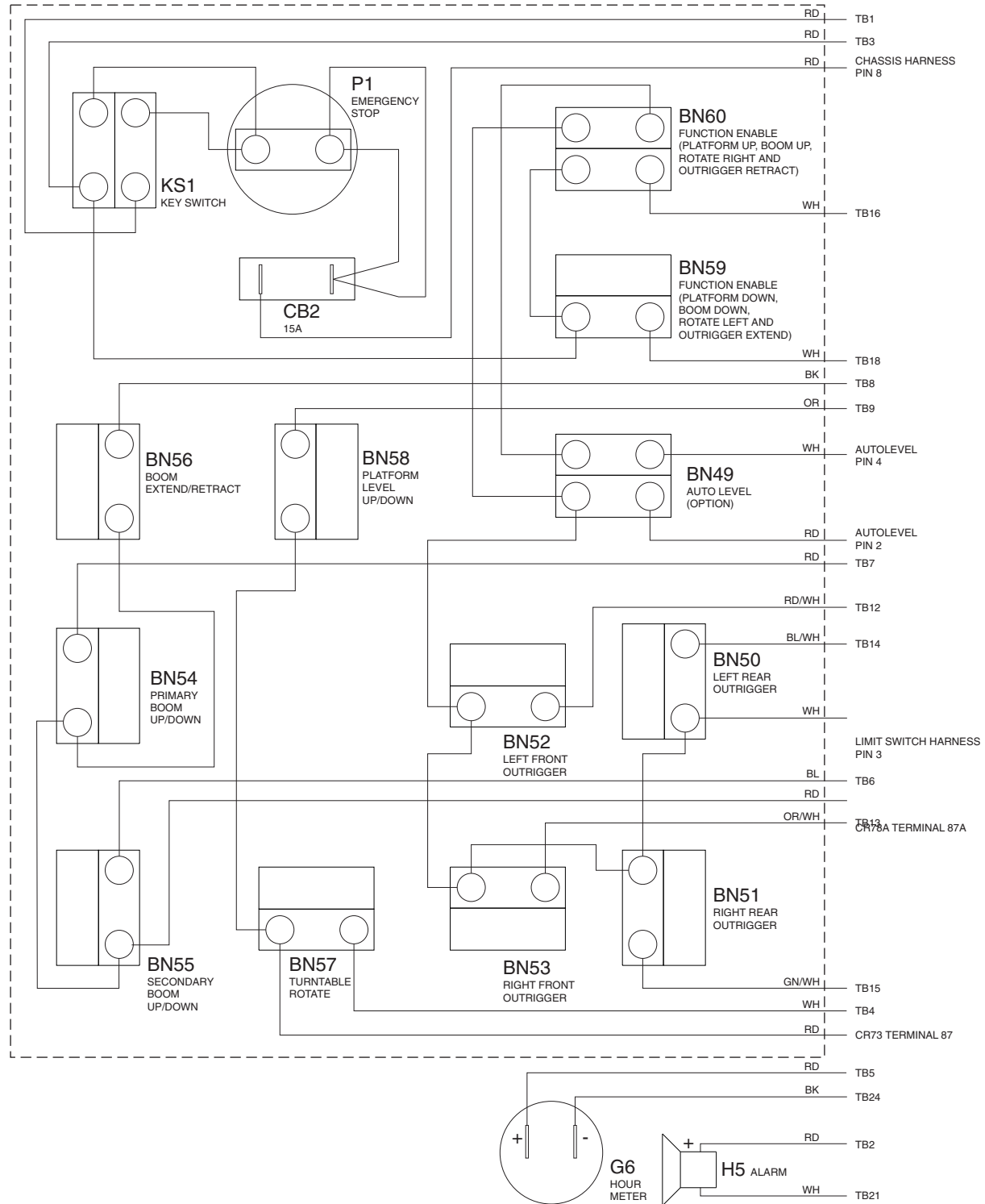

Ground Control Box Wiring Diagram - ANSI/CSA

(from serial number TZ3403-186 to TZ3403-248)

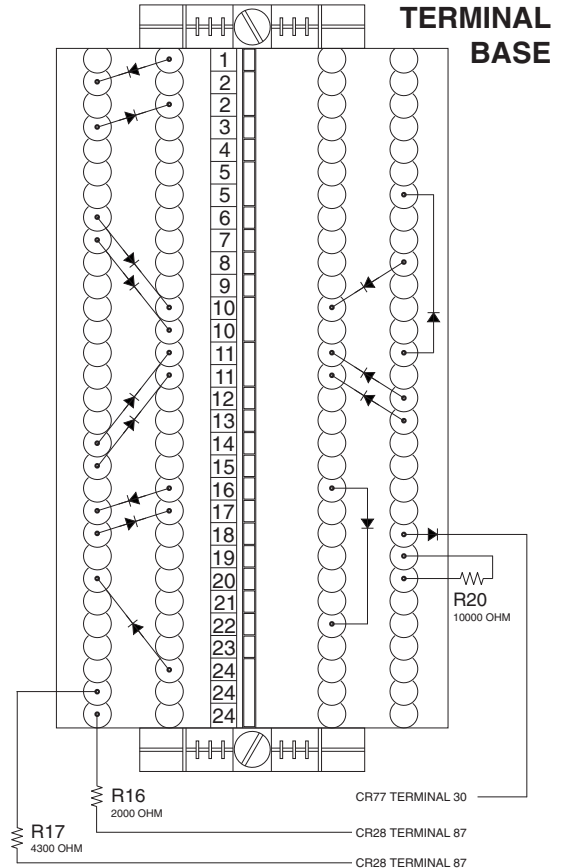
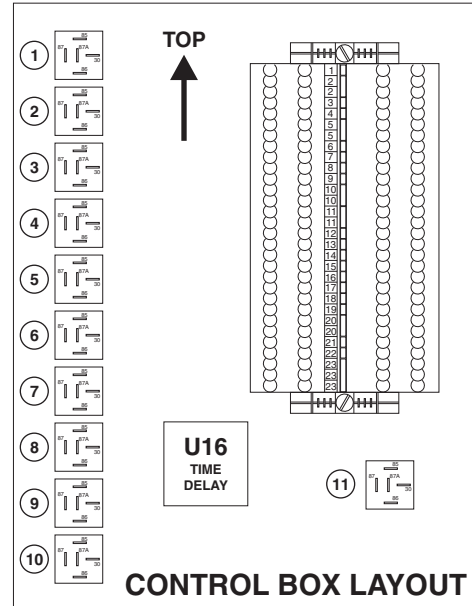
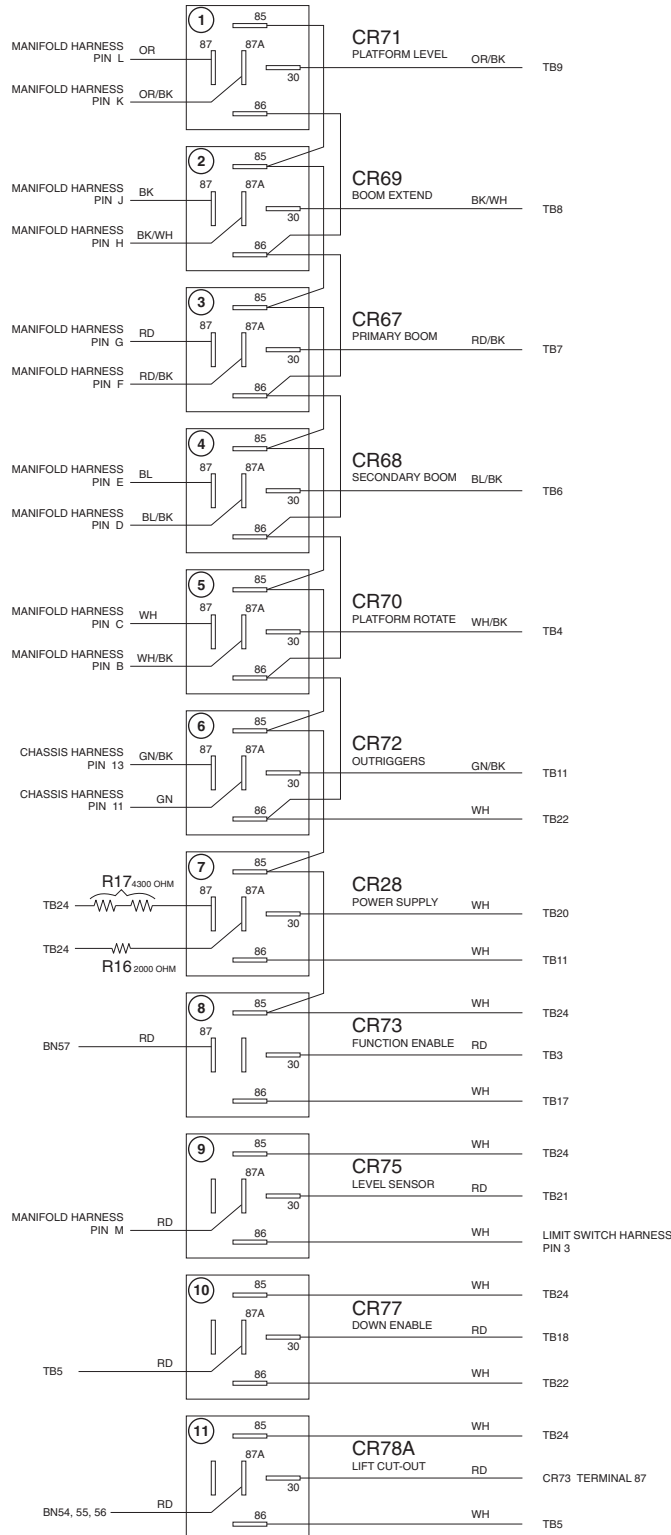

Ground Control Box Wiring Diagram - ANSI/CSA

(from serial number TZ3403-249 to TZ3404-303)

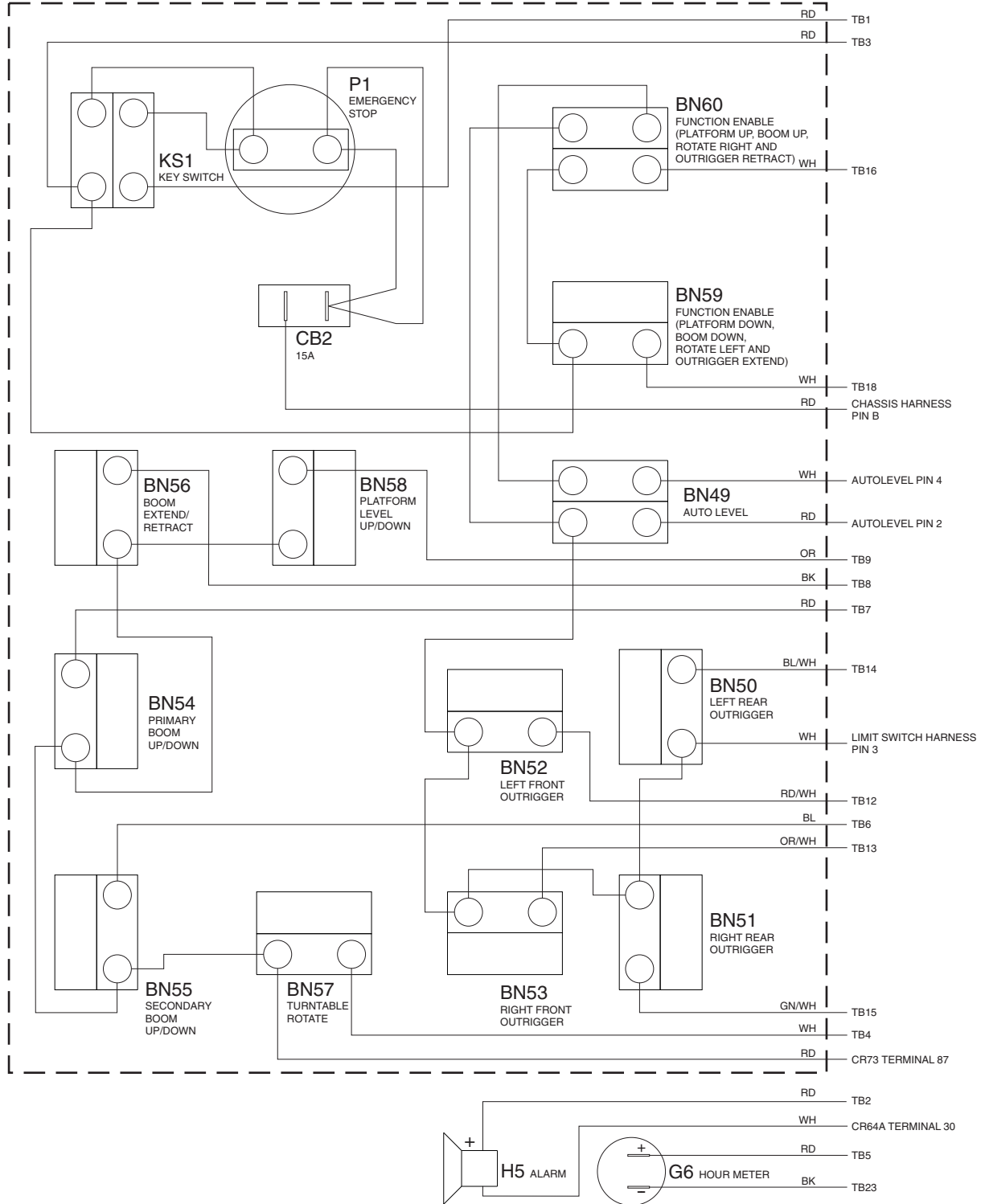

Ground Control Box Wiring Diagram - ANSI/CSA

(from serial number TZ3404-304 to TZ3404-505)

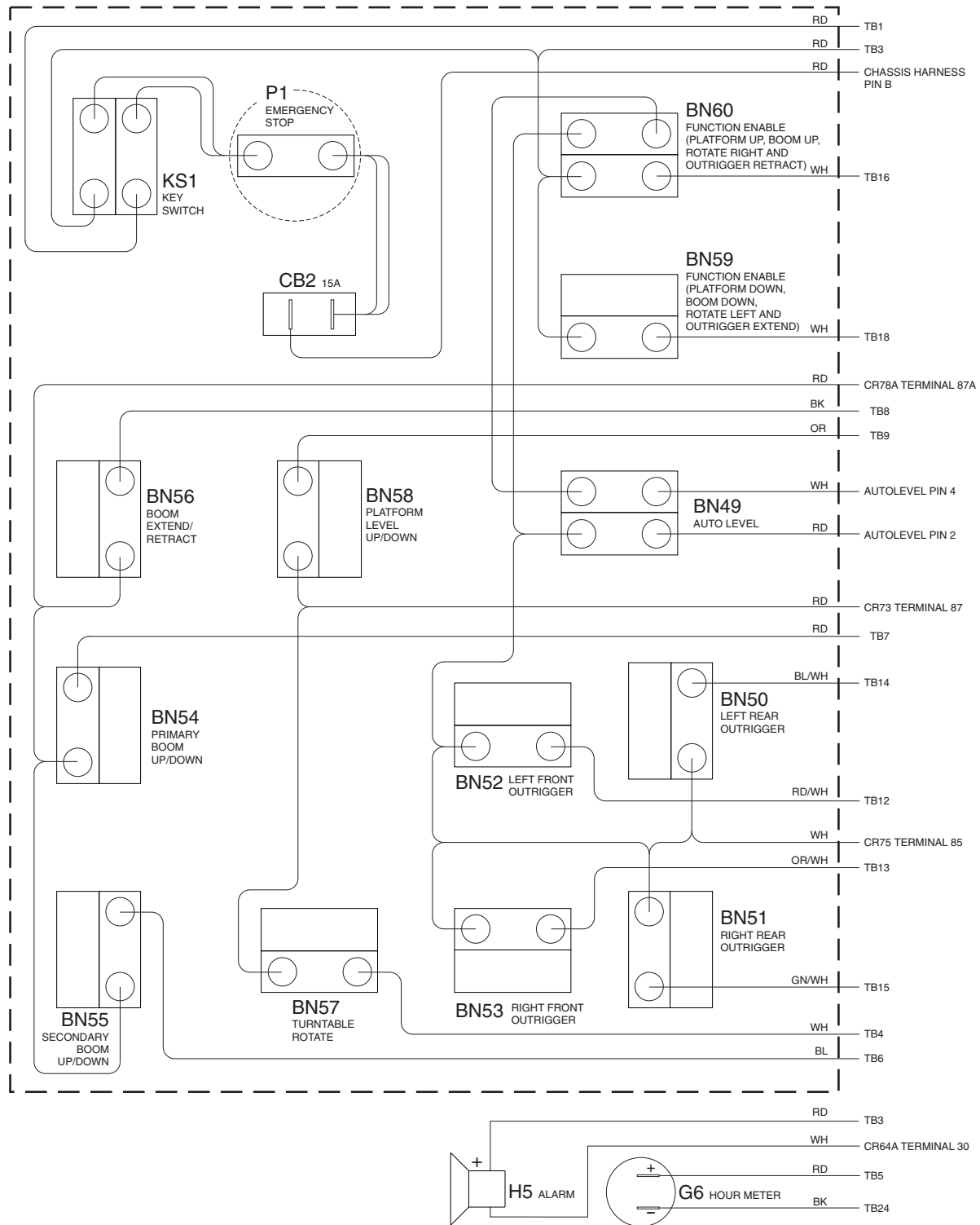

Ground Control Box Wiring Diagram - ANSI/CSA

(from serial number TZ3404-304 to TZ3404-505)

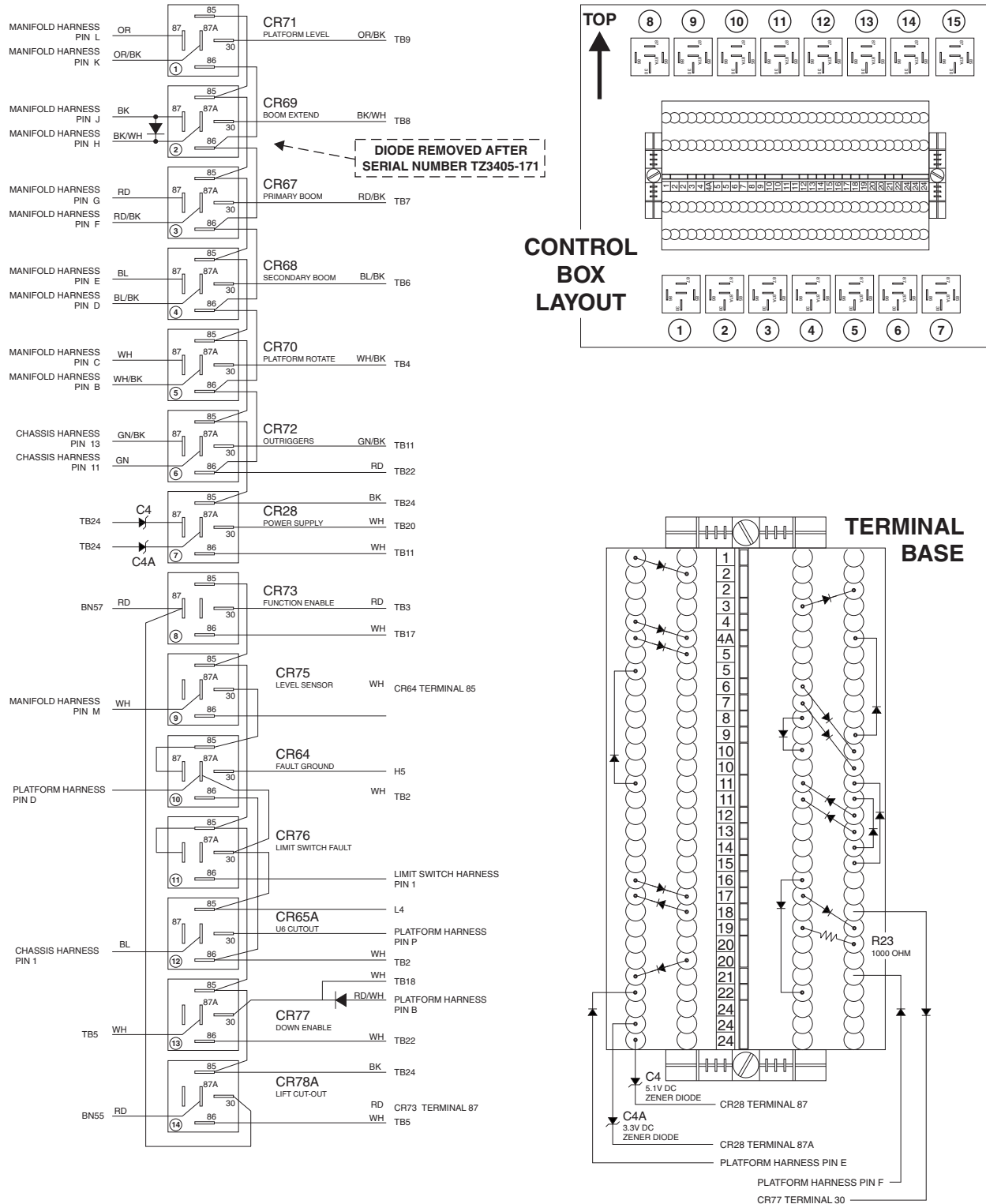

Ground Control Box Wiring Diagram - ANSI/CSA

(from serial number TZ3404-506 to TZ3405-189)

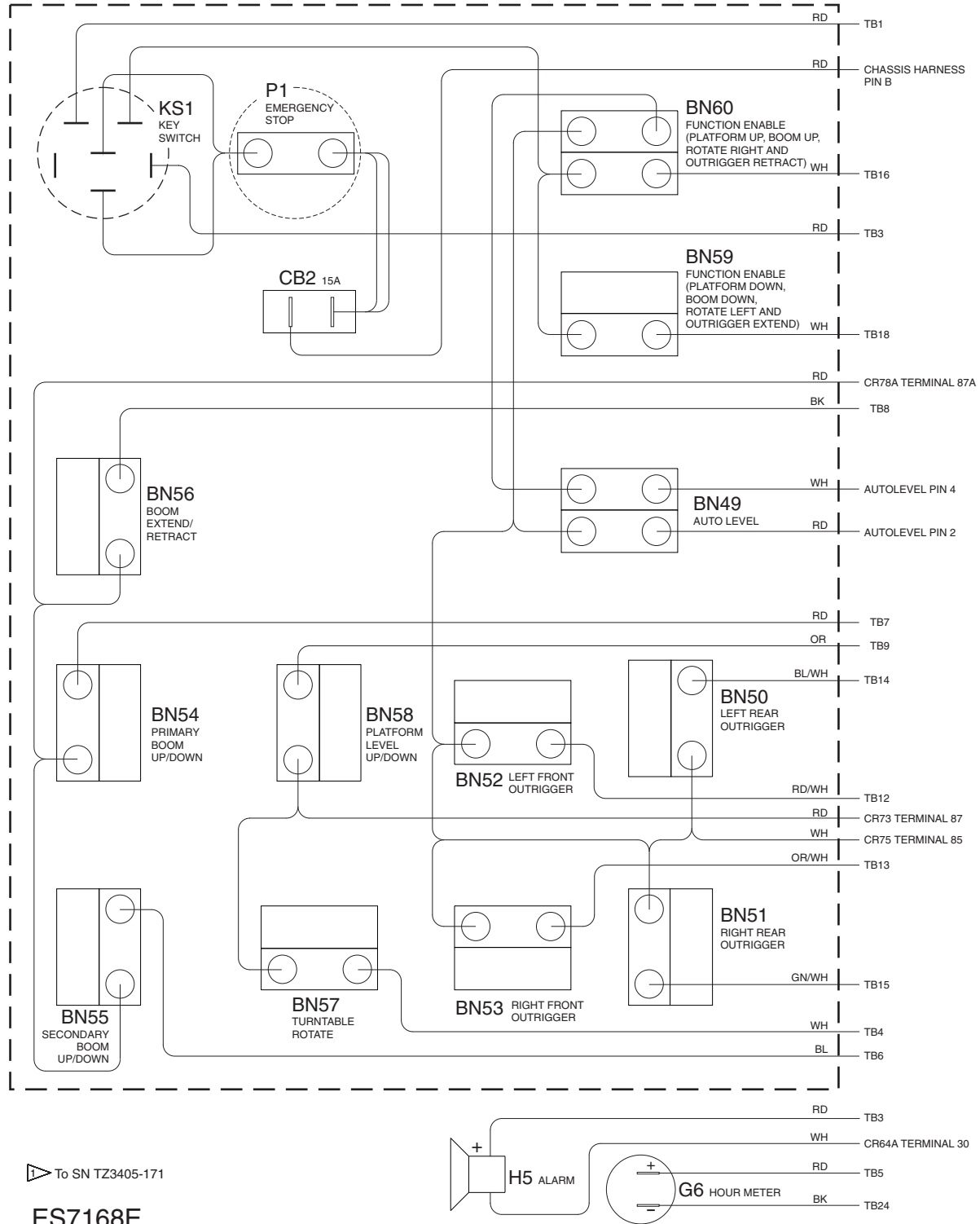

▶ To SN TZ3405-171

ES7168E



Ground Control Box Wiring Diagram - ANSI/CSA

(from serial number TZ3404-506 to TZ3405-189)

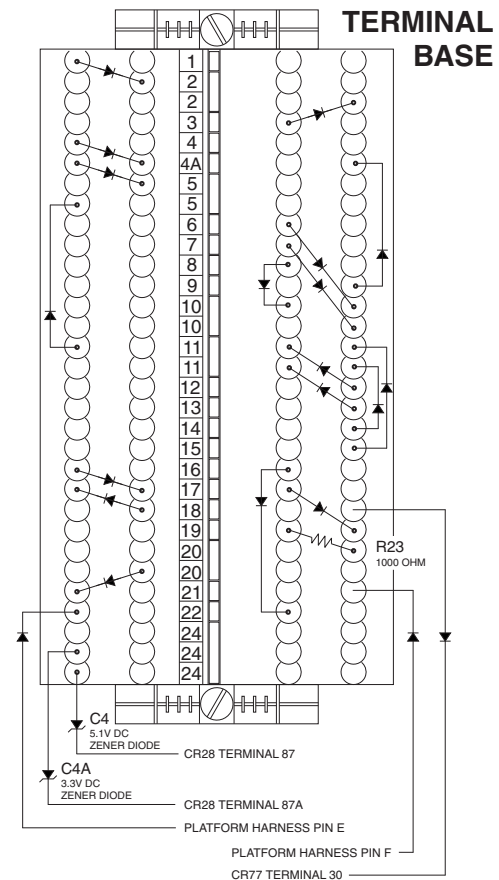
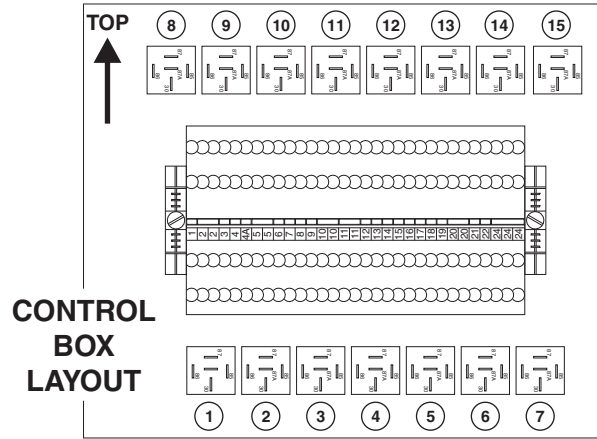
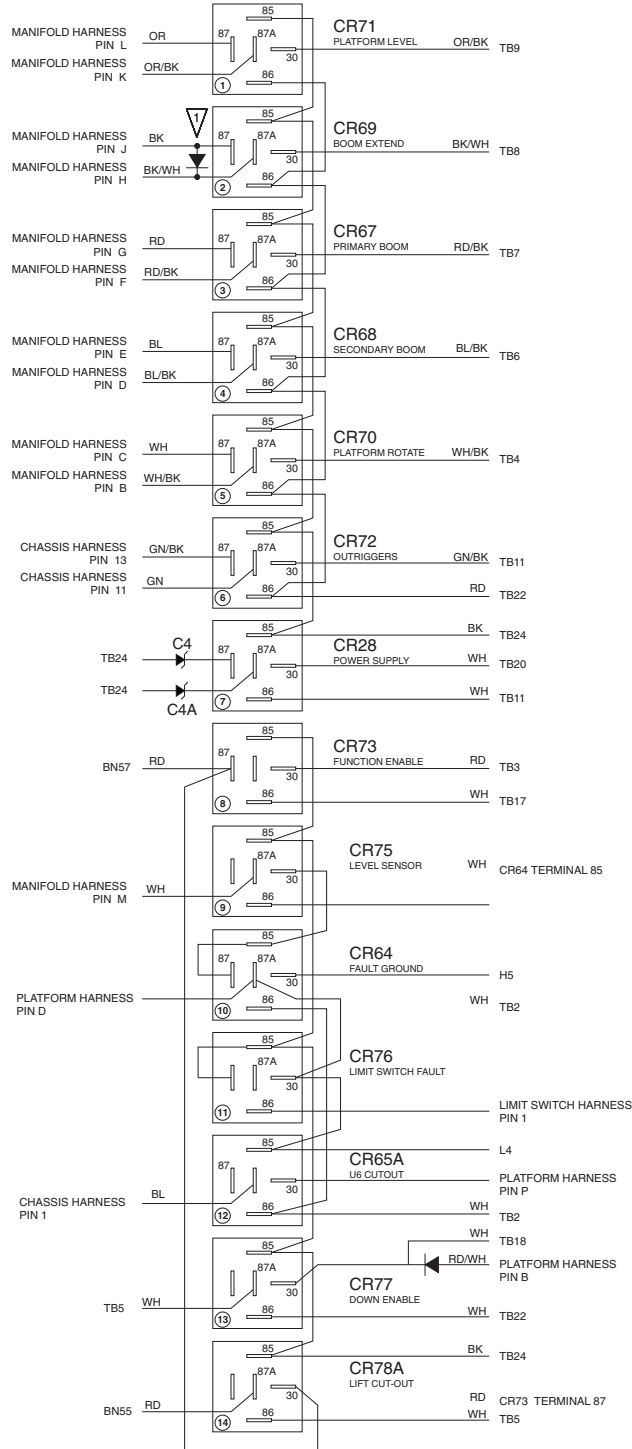

▷ To SN TZ3405-171

ES7168E



Ground Control Box Wiring Diagram - ANSI/CSA

(from serial number TZ3405-190 to TZ3406-204)

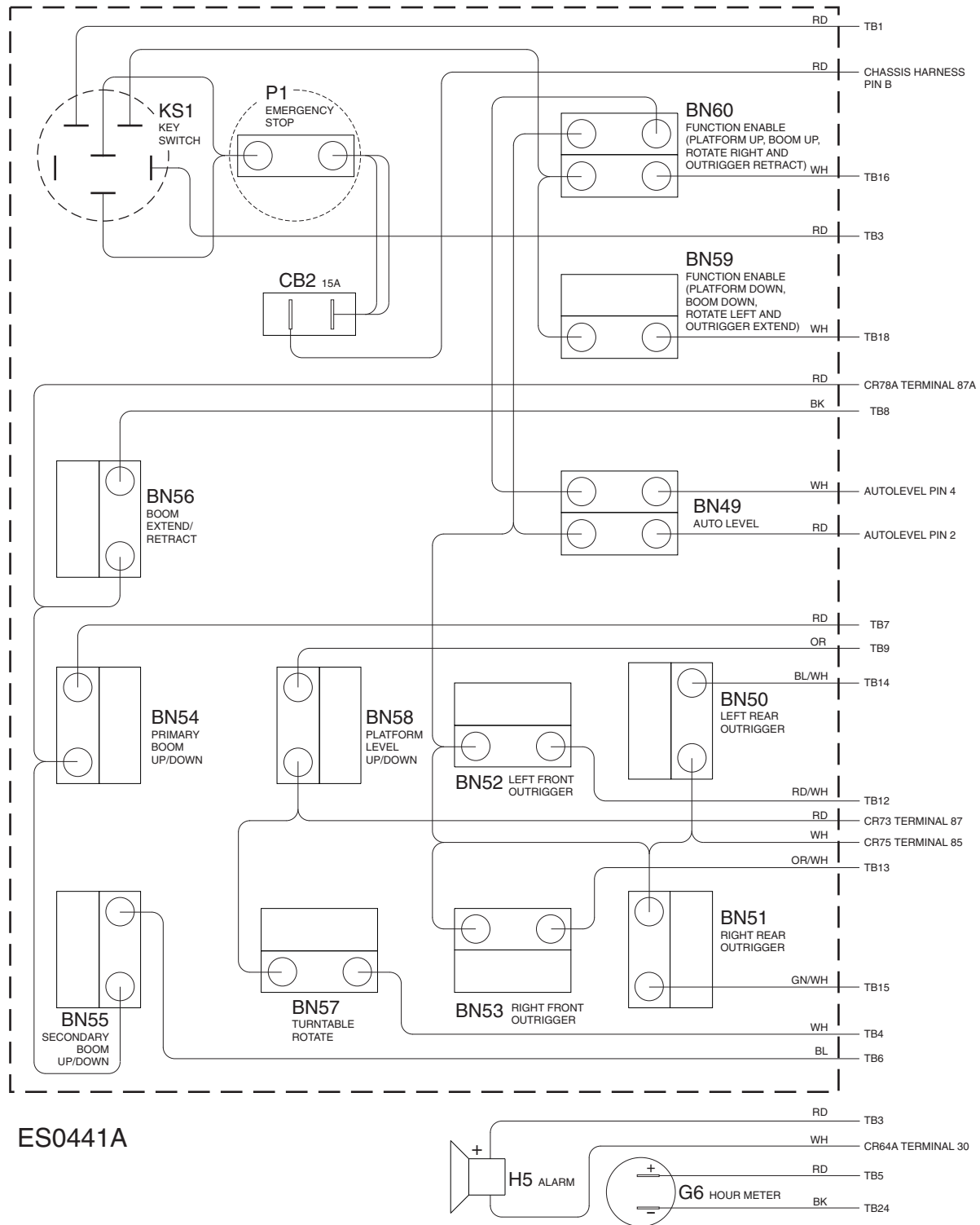

Ground Control Box Wiring Diagram - ANSI/CSA

(from serial number TZ3405-190 to TZ3406-204)

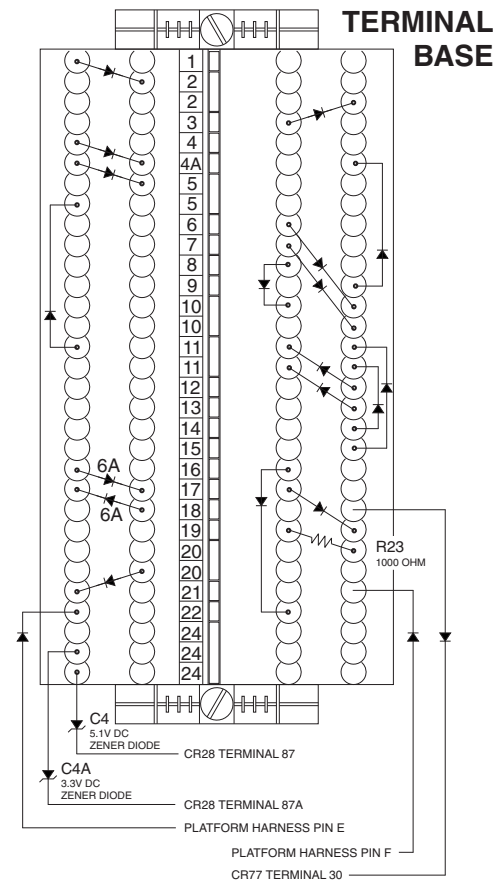
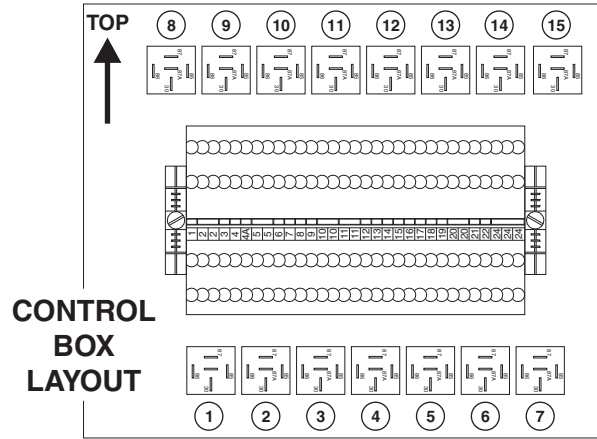
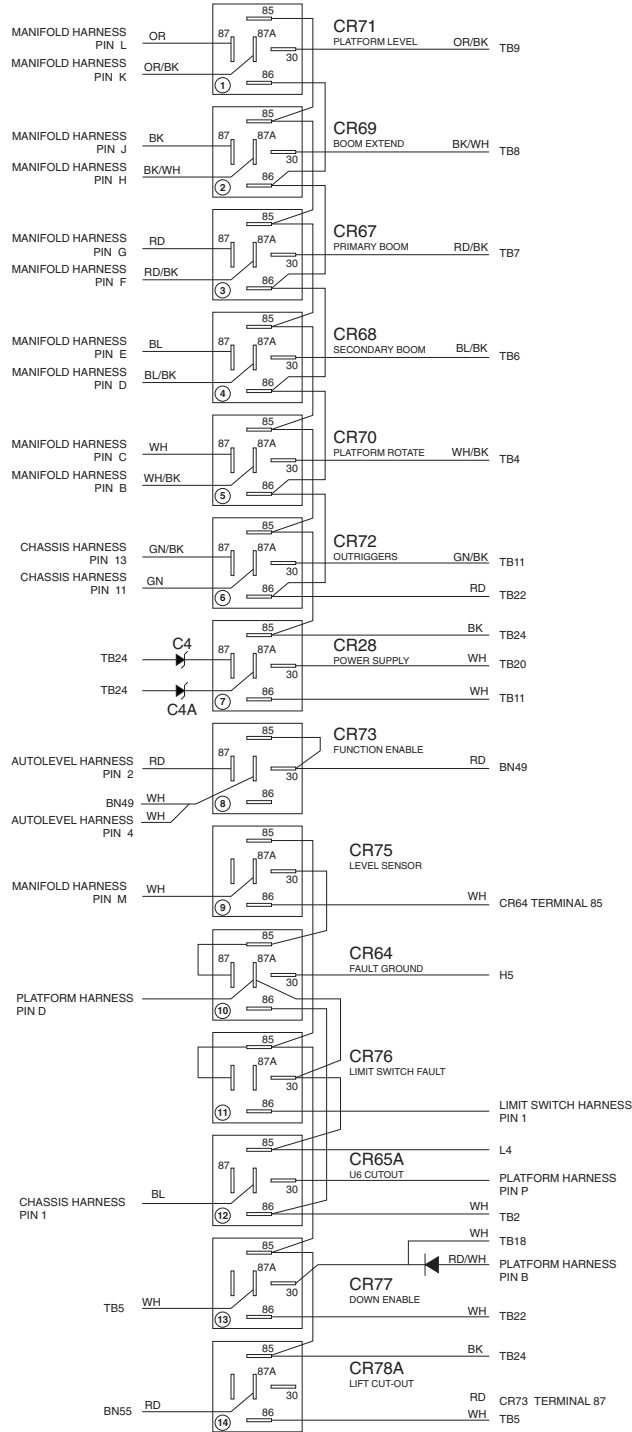

ES0441A



Ground Control Box Wiring Diagram - ANSI/CSA

(from serial number TZ3406-205)

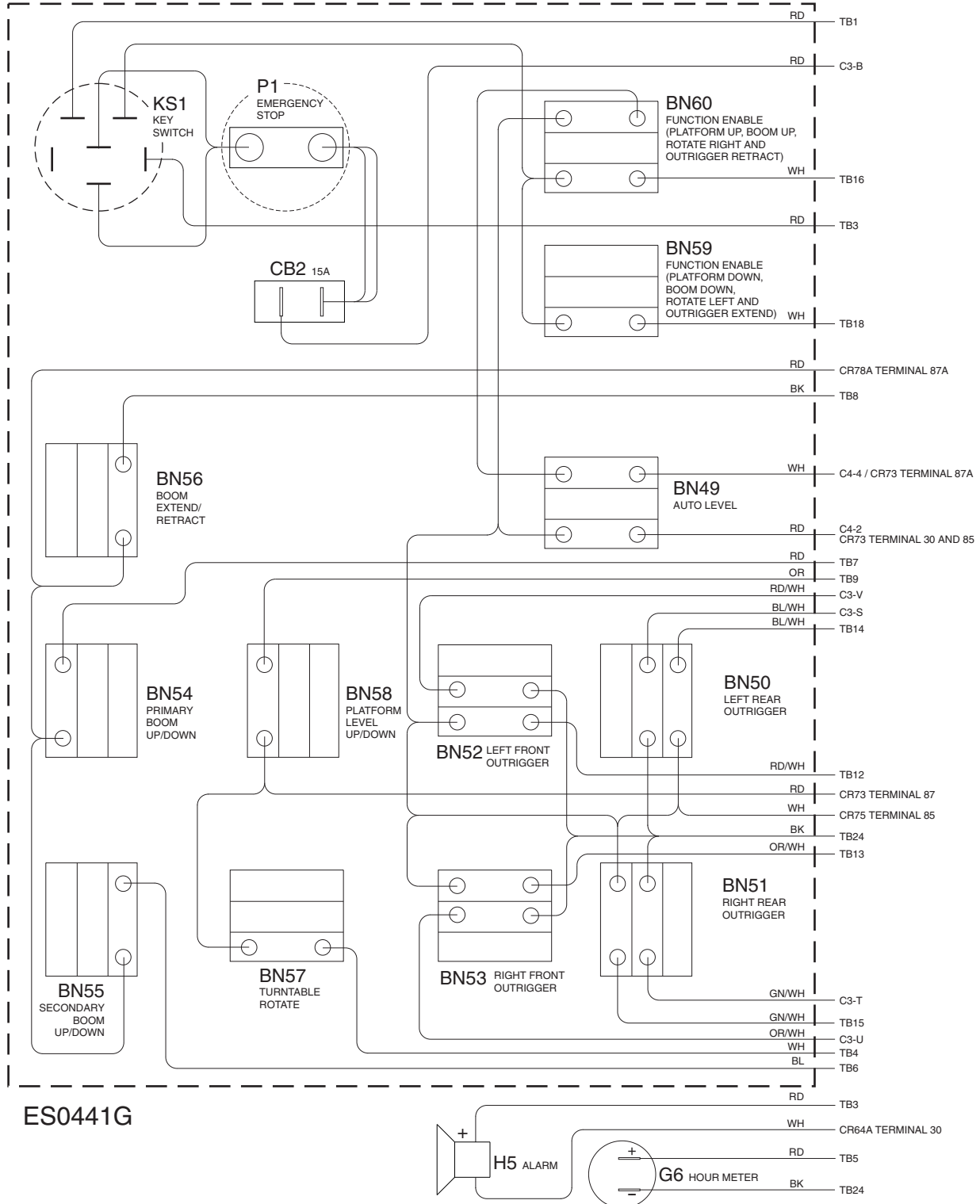

Ground Control Box Wiring Diagram - ANSI/CSA (from serial number TZ3406-205)

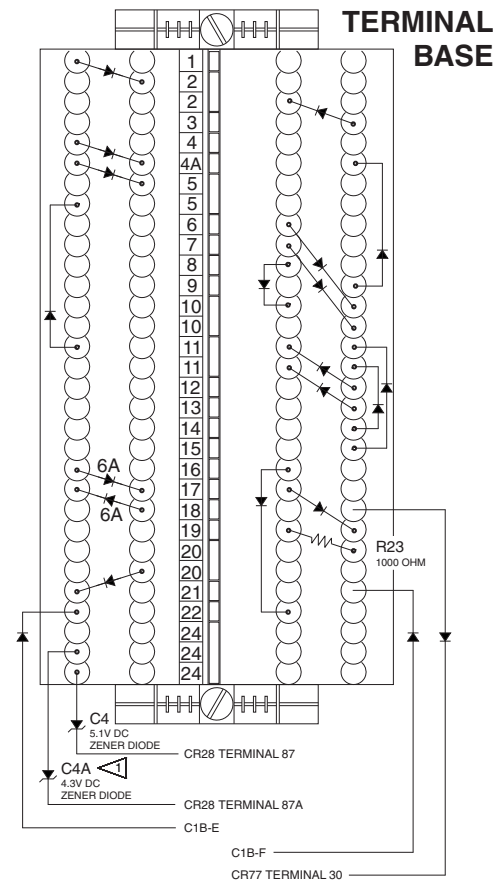
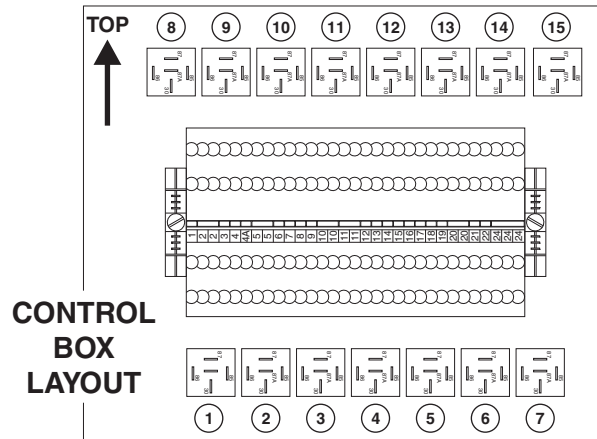
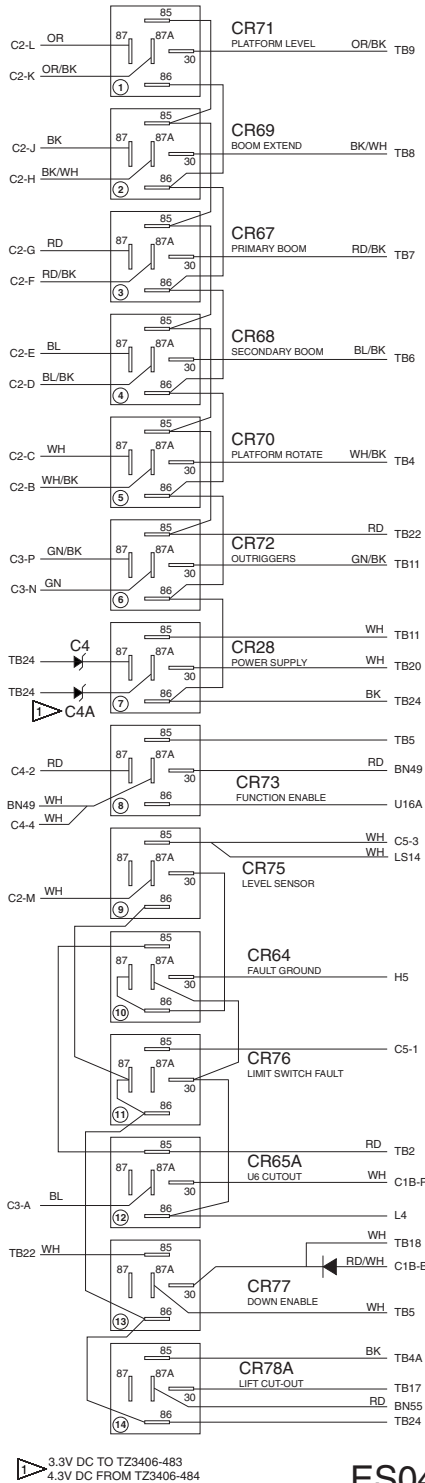

Platform Control Box Wiring Diagram - ANSI/CSA

(to serial number TZ3403-185)

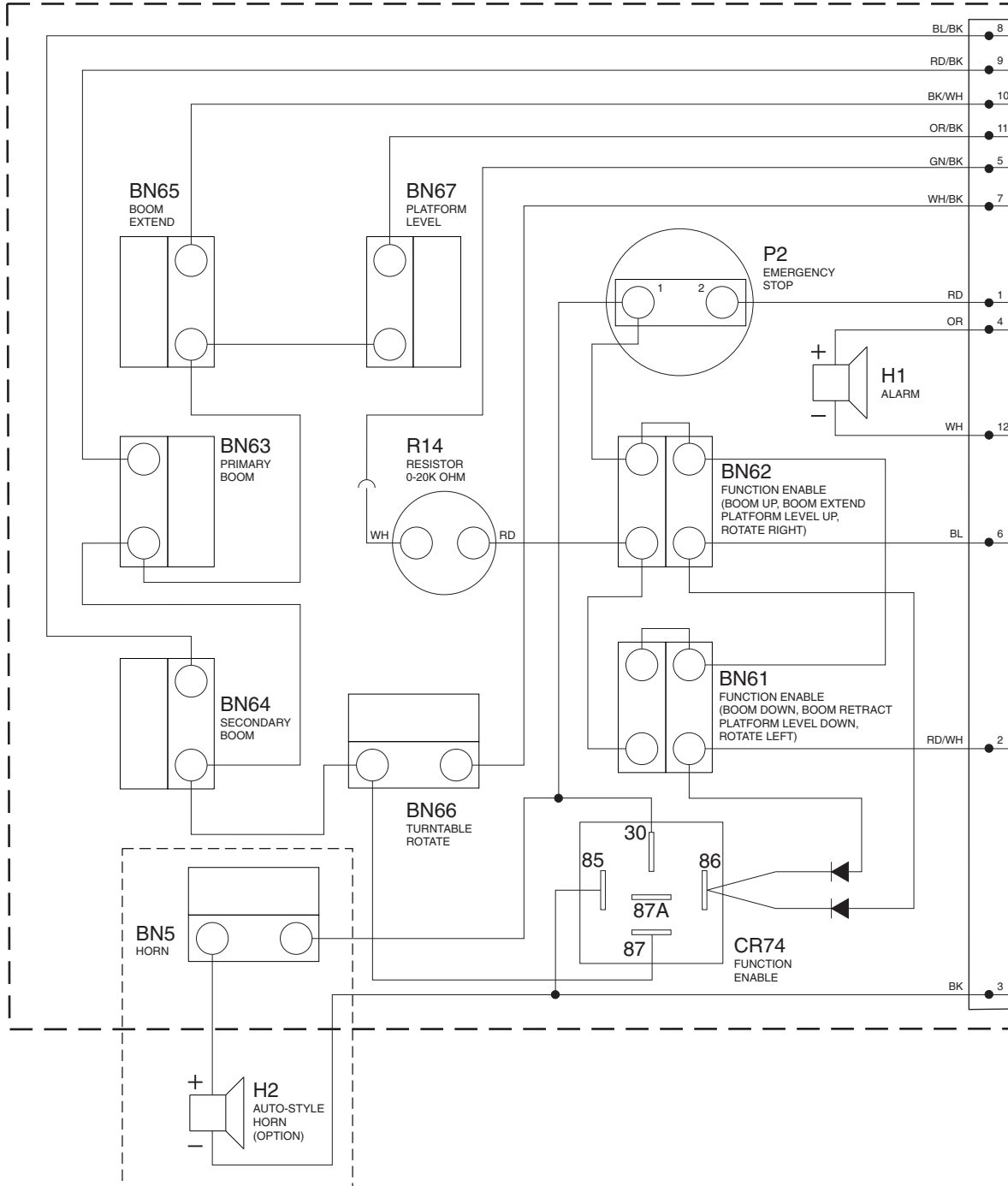

Platform Control Box Wiring Diagram - ANSI/CSA

(from serial number TZ3403-186 to TZ3403-248)

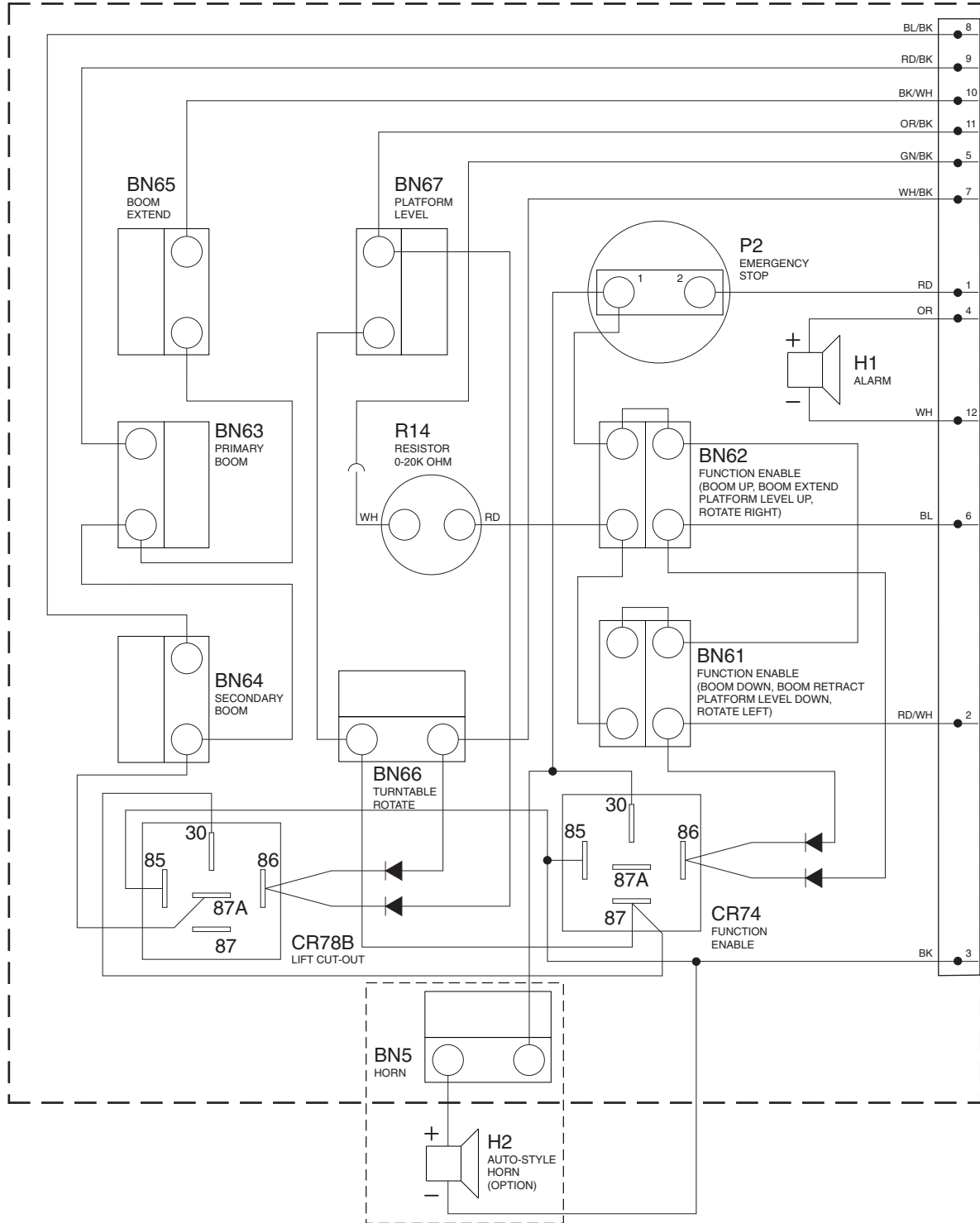

Platform Control Box Wiring Diagram - ANSI/CSA

(from serial number TZ3403-249 to TZ3404-303)

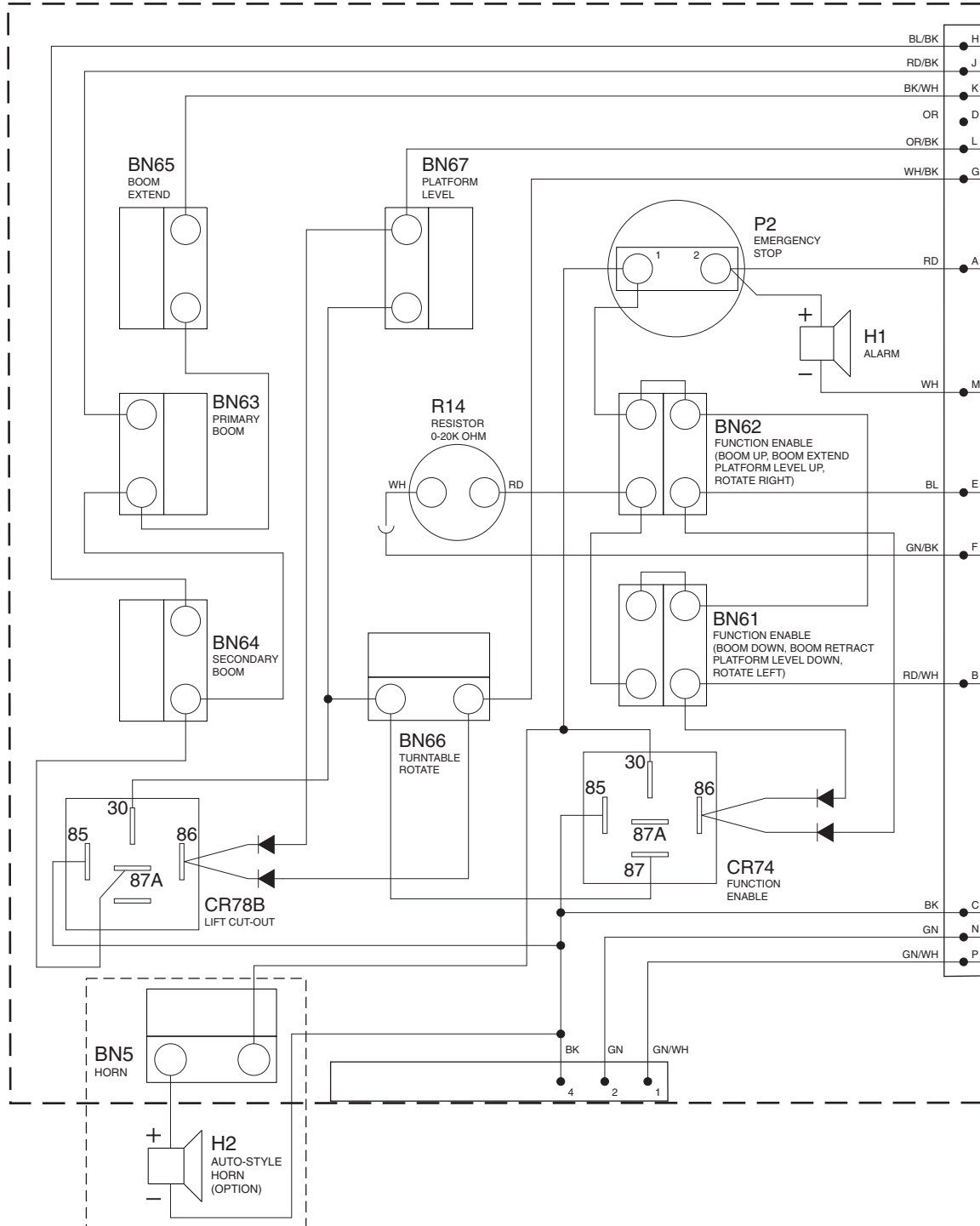

Platform Control Box Wiring Diagram - ANSI/CSA (from serial number TZ3404-304 to TZ3406-204)

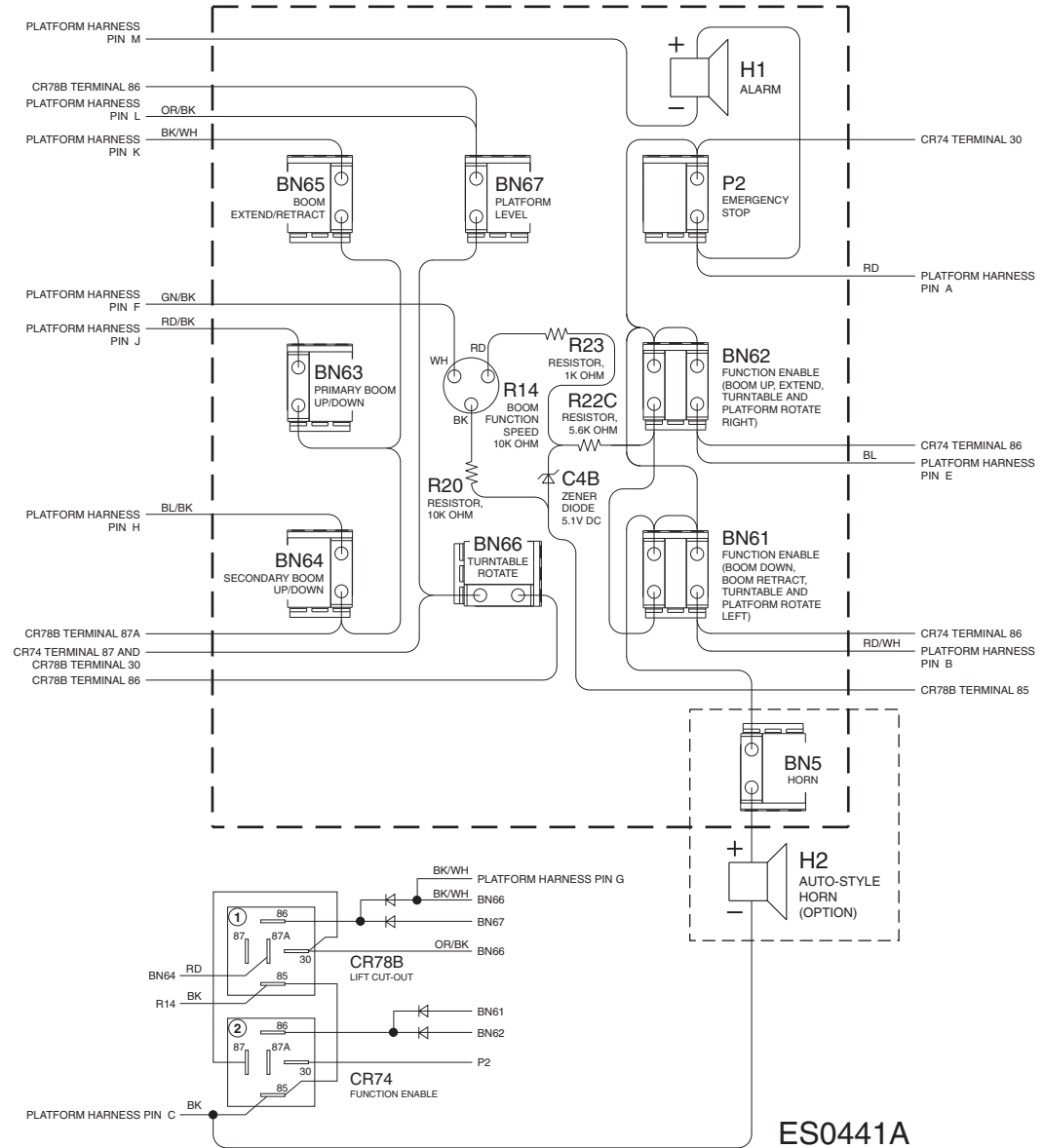

Platform Control Box Wiring Diagram - ANSI/CSA

(from serial number TZ3406-205)

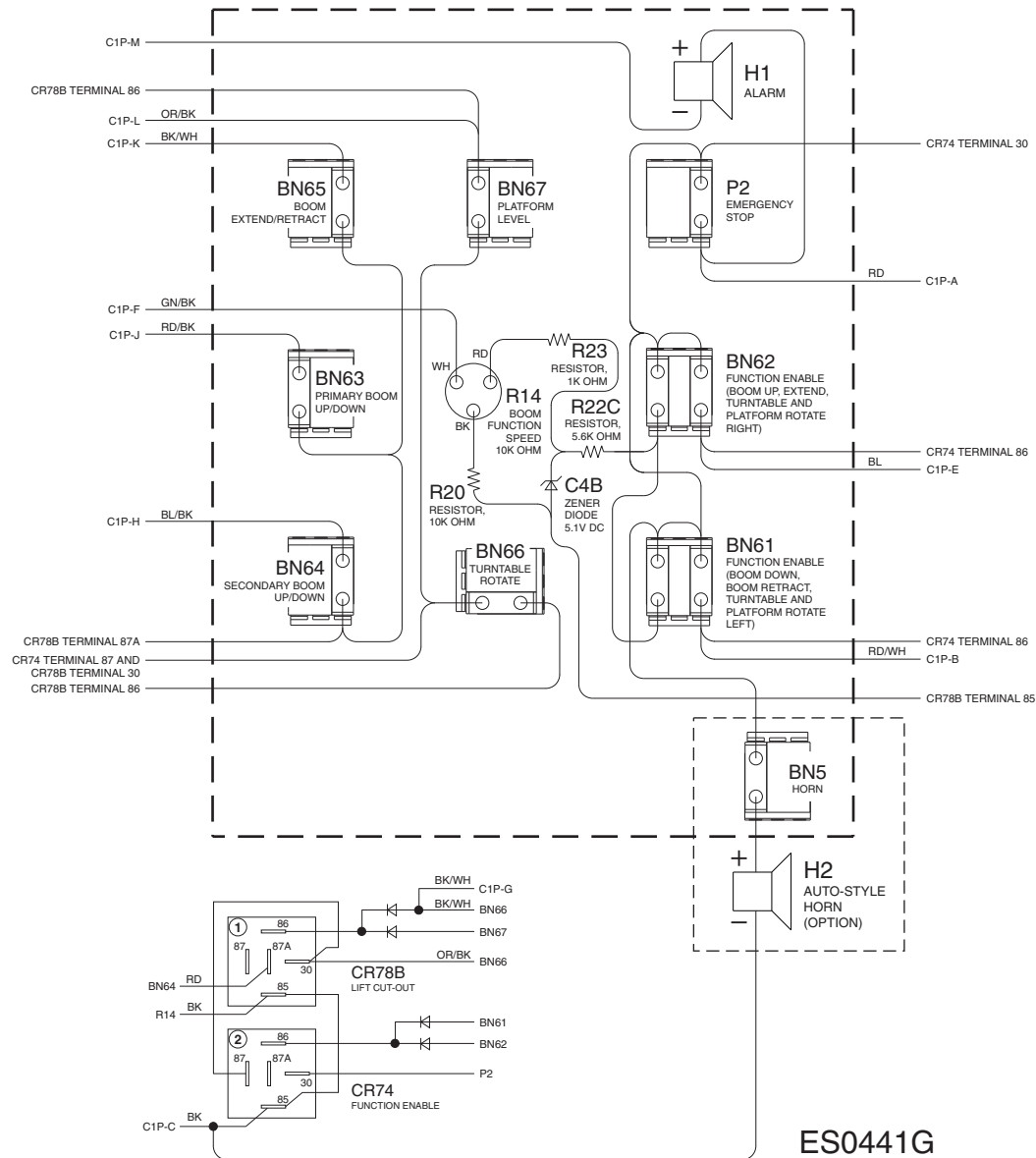

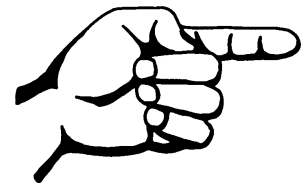

This page intentionally left blank.

Ground Control Box Wiring Diagram - AS/CE

(to serial number TZ3404-303)

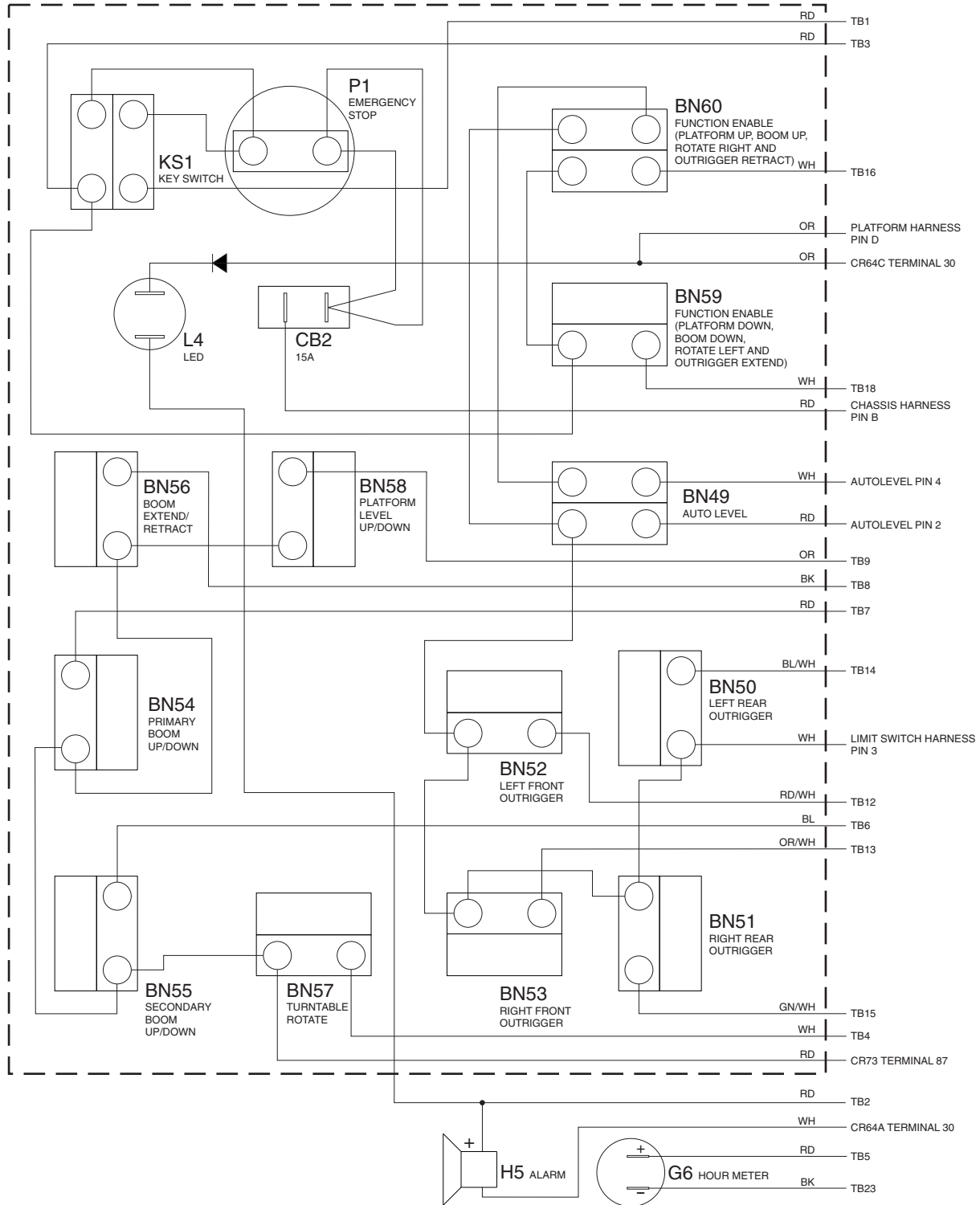

Ground Control Box Wiring Diagram - AS/CE

(to serial number TZ3404-303)

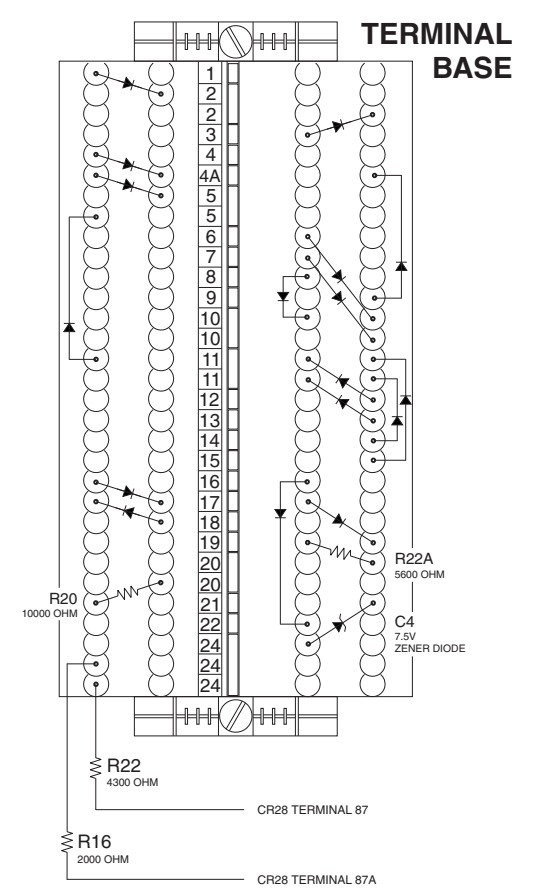
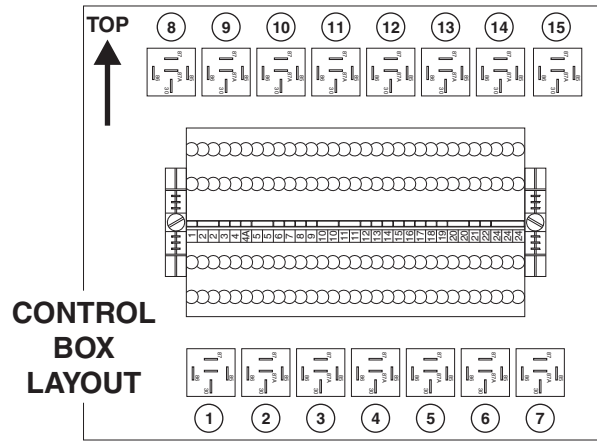
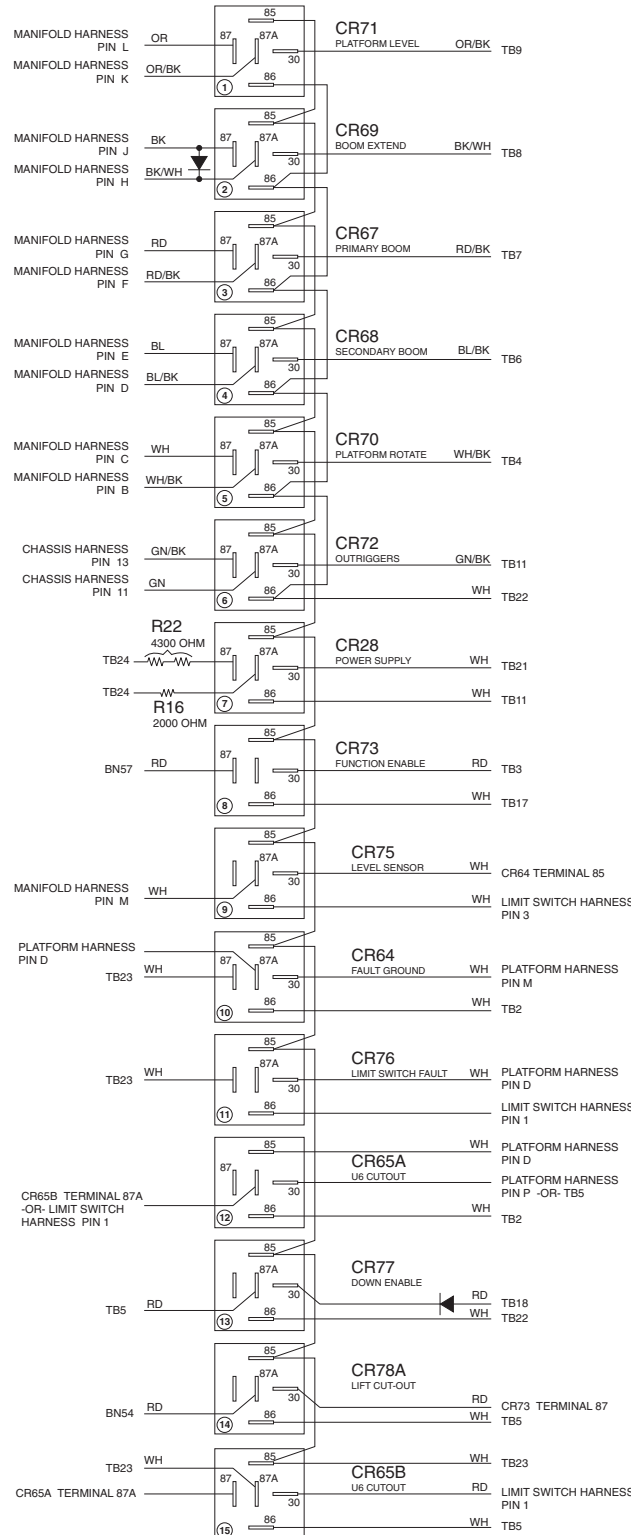

Ground Control Box Wiring Diagram - AS/CE

(from serial number TZ3404-304 to TZ3404-505)

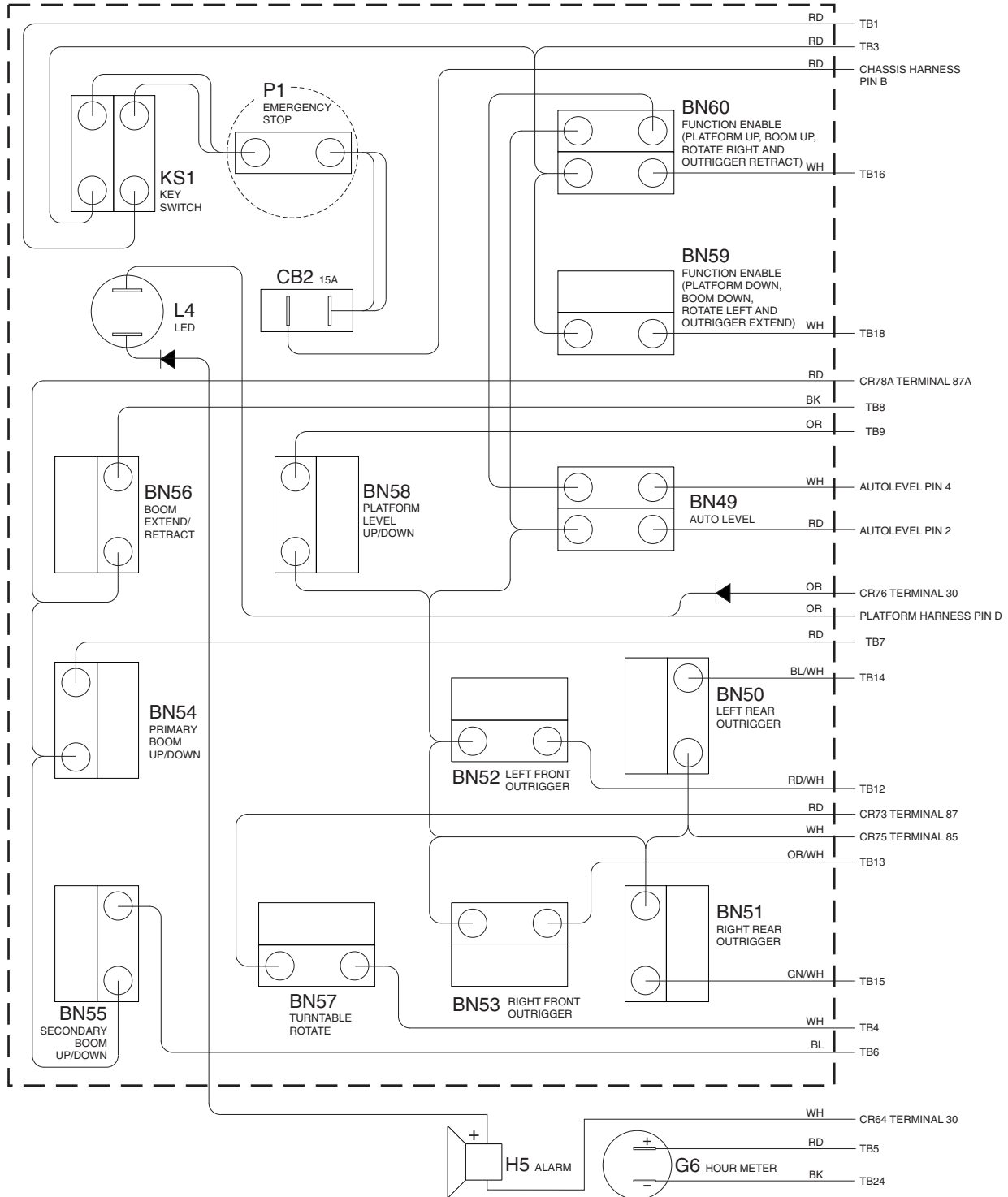

Ground Control Box Wiring Diagram - AS/CE

(from serial number TZ3404-304 to TZ3404-505)

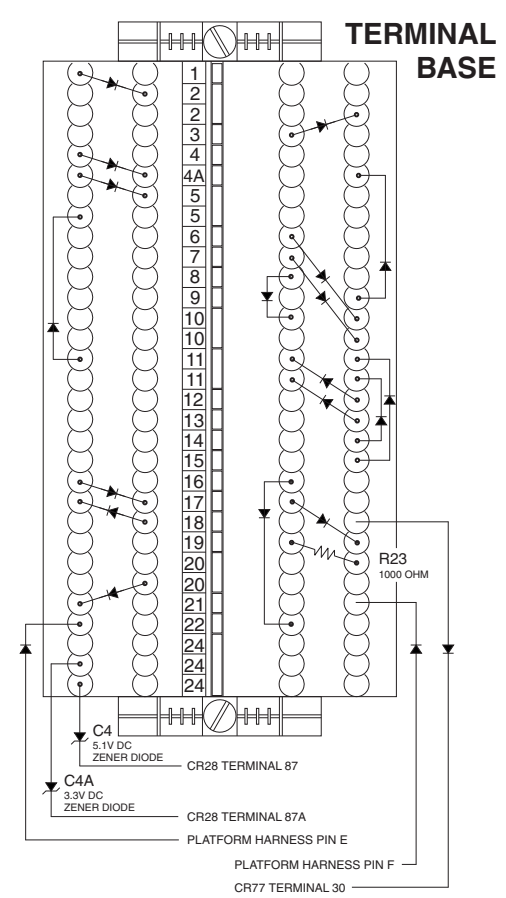
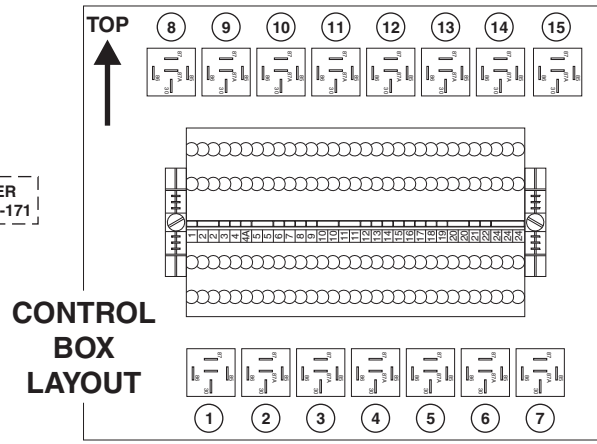
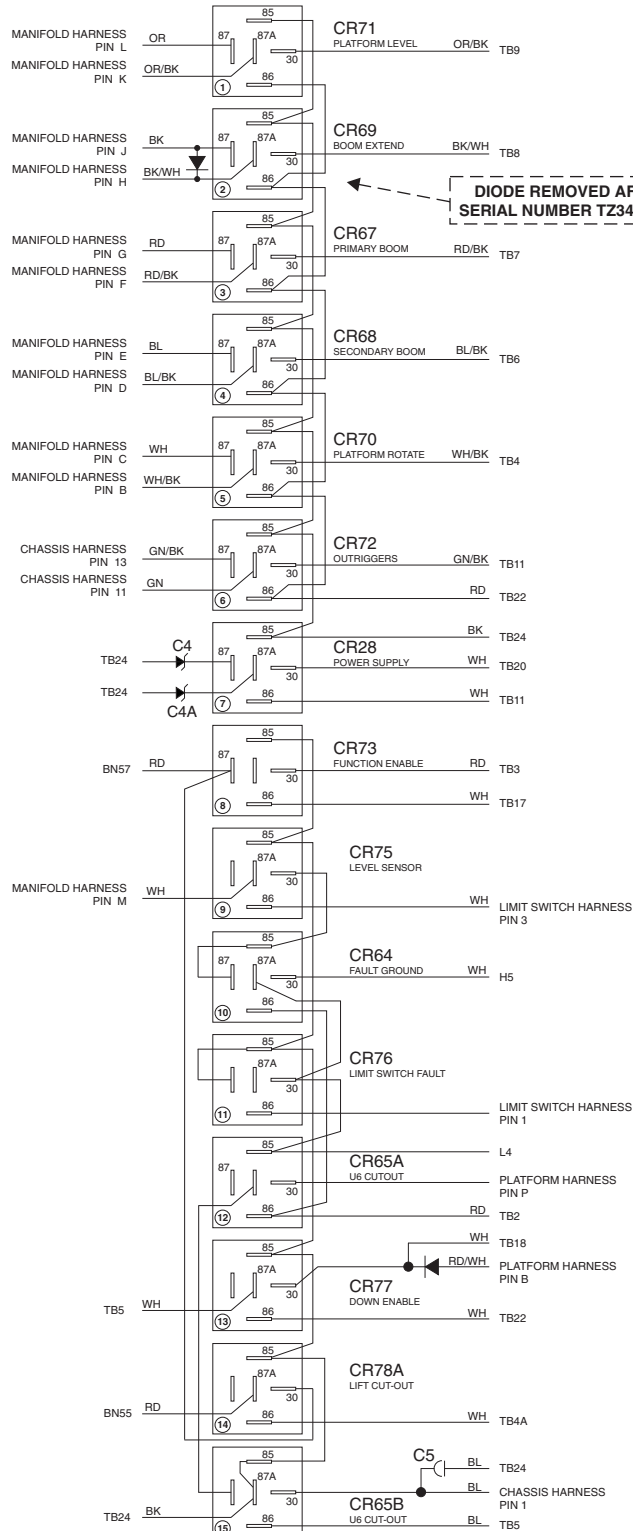

Ground Control Box Wiring Diagram - AS/CE

(from serial number TZ3404-506 to TZ3405-189)

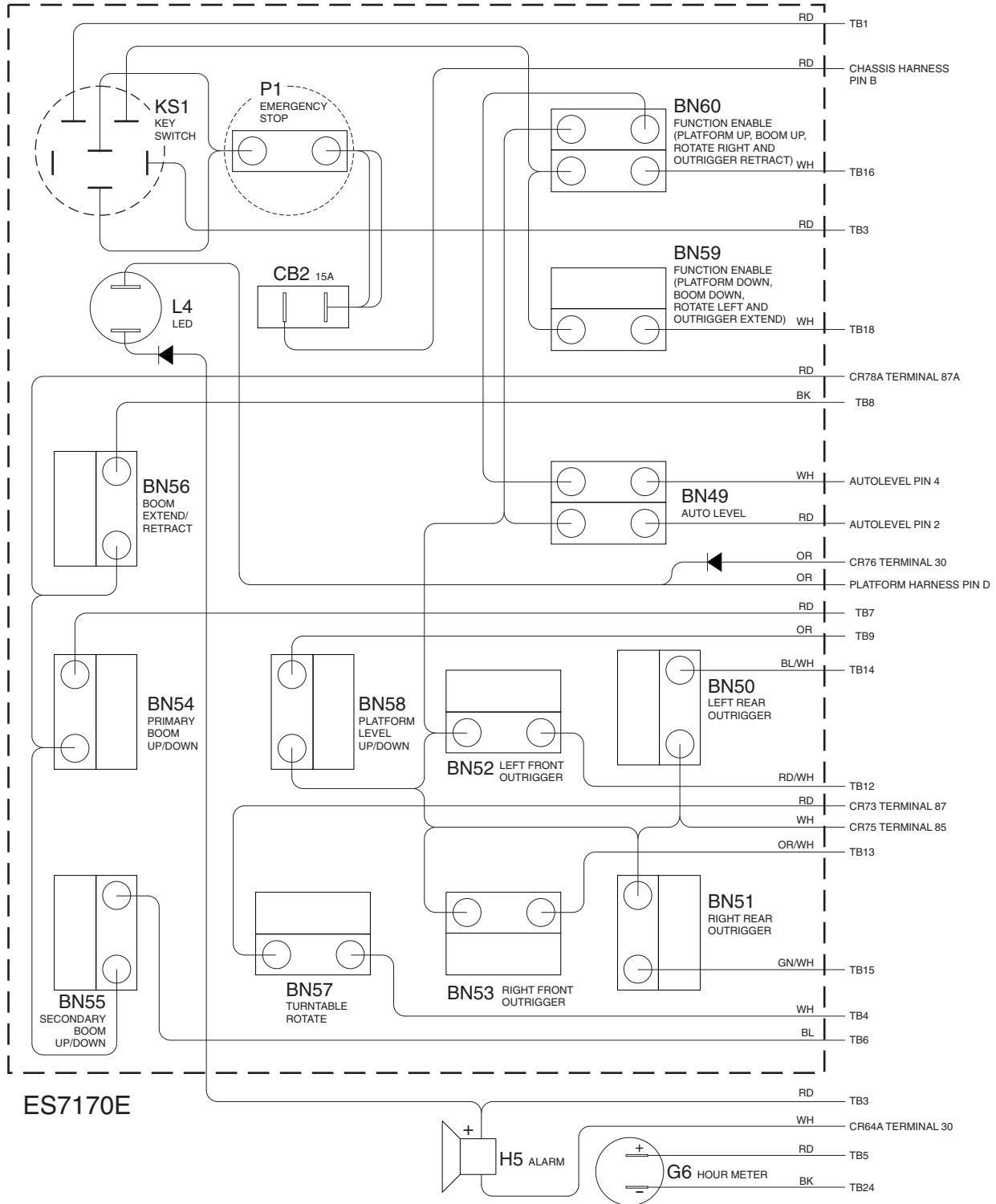

Ground Control Box Wiring Diagram - AS/CE

(from serial number TZ3404-506 to TZ3405-189)

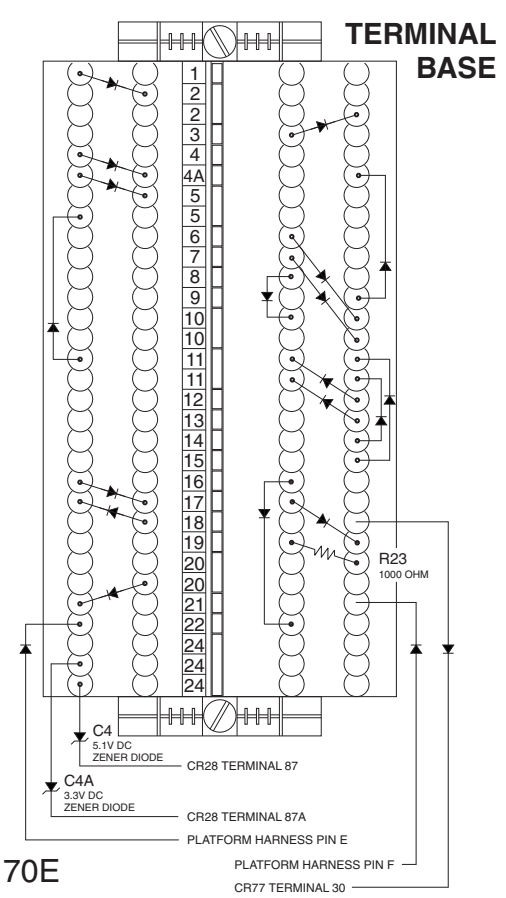
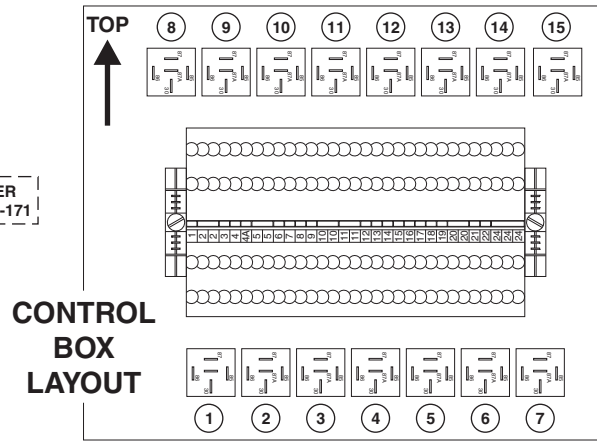
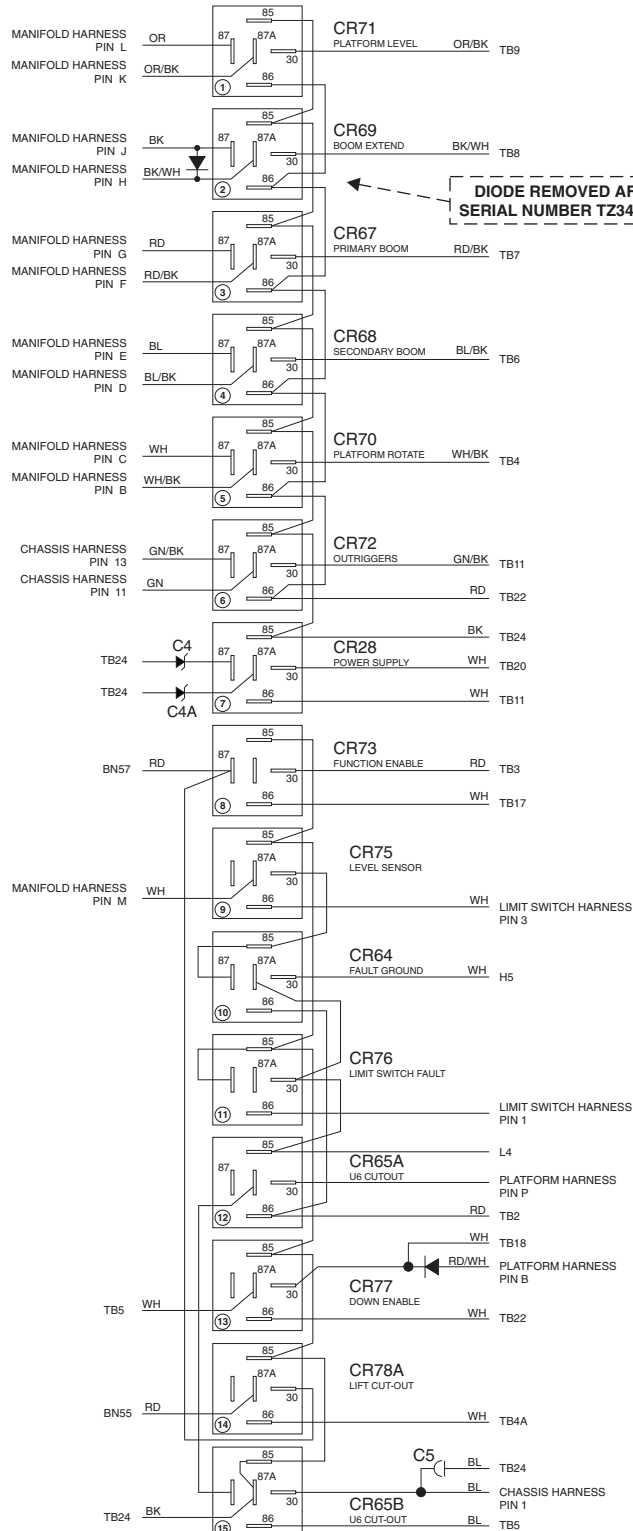

ES7170E



Ground Control Box Wiring Diagram - AS/CE

(from serial number TZ3405-190 to TZ3406-204)

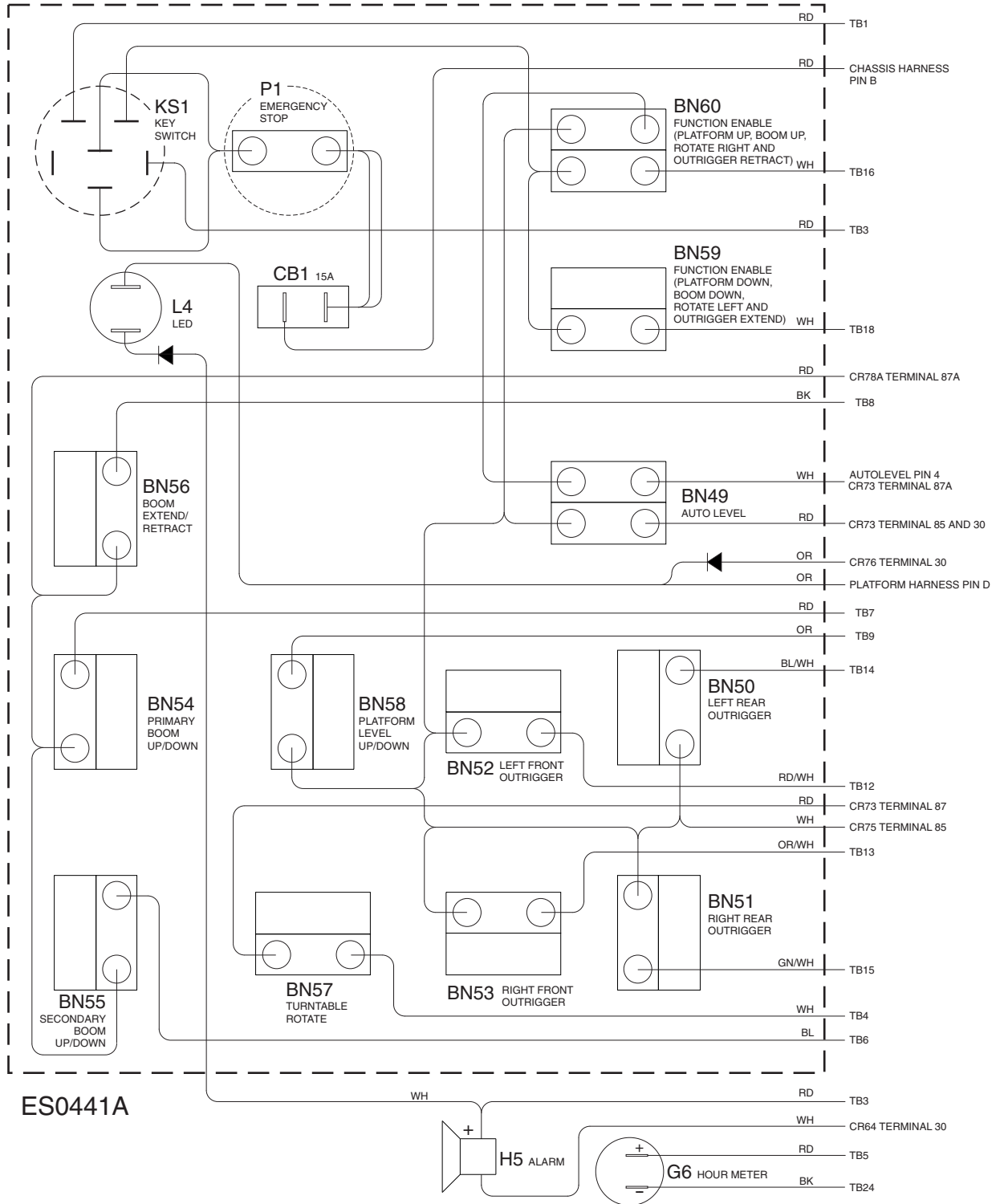

Ground Control Box Wiring Diagram - AS/CE

(from serial number TZ3405-190 to TZ3406-204)

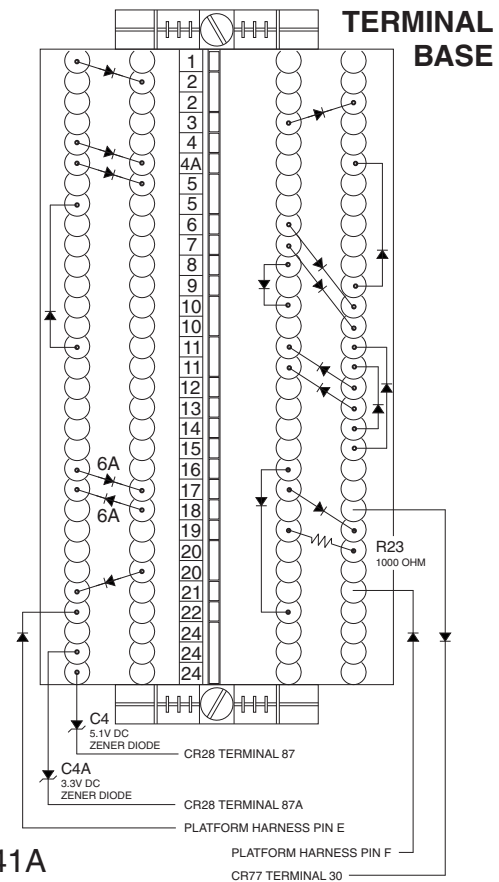
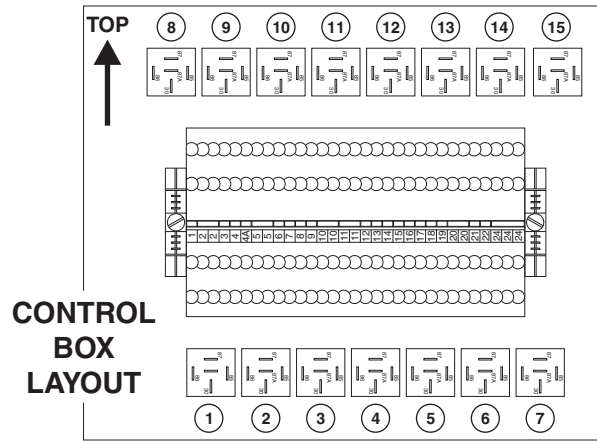
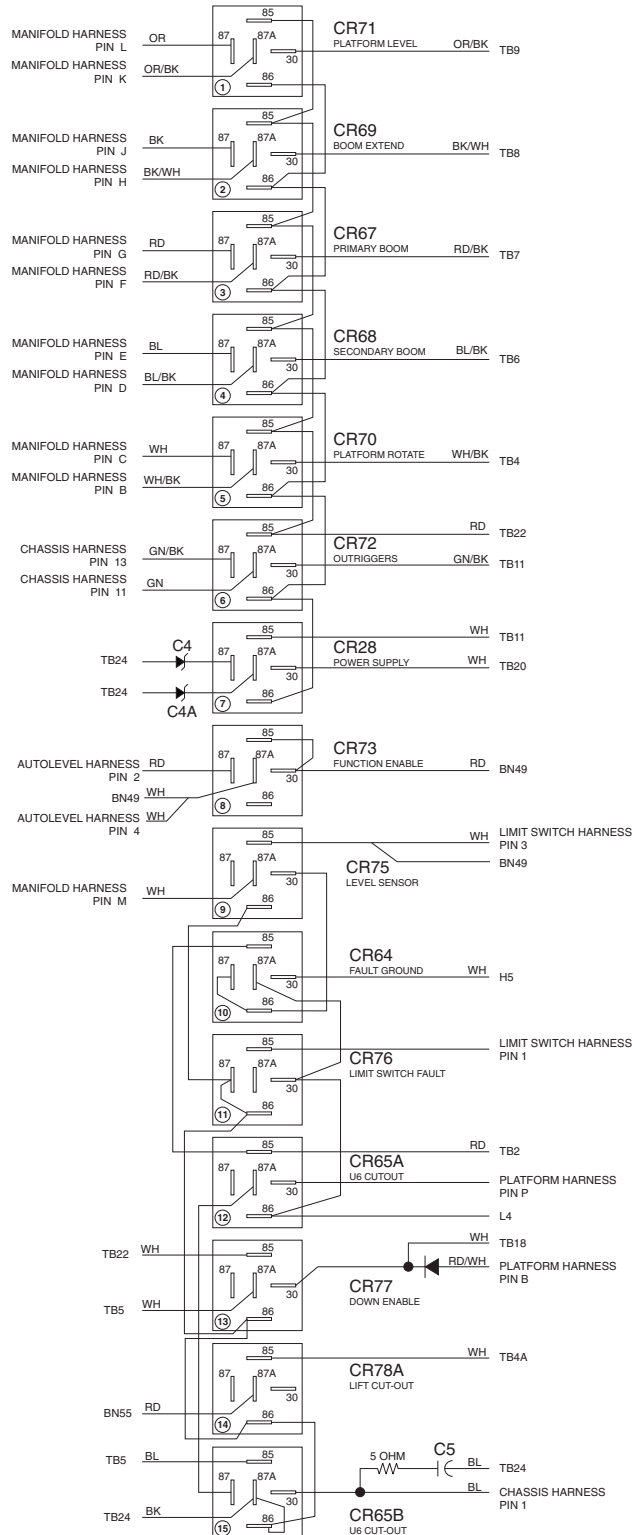

ES0441A



Ground Control Box Wiring Diagram - AS/CE

(from serial number TZ3406-205)

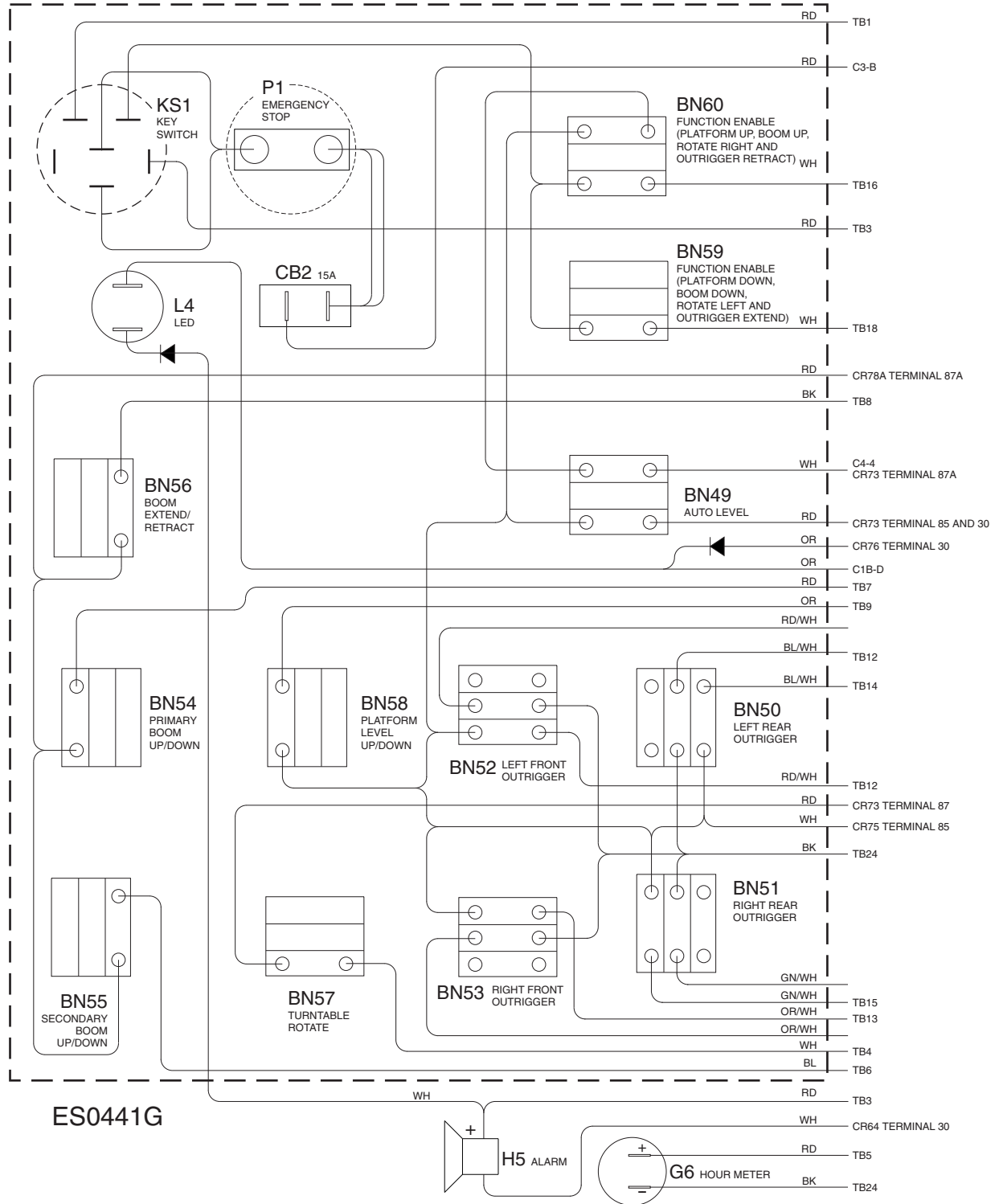

Ground Control Box Wiring Diagram - AS/CE

(from serial number TZ3406-205)

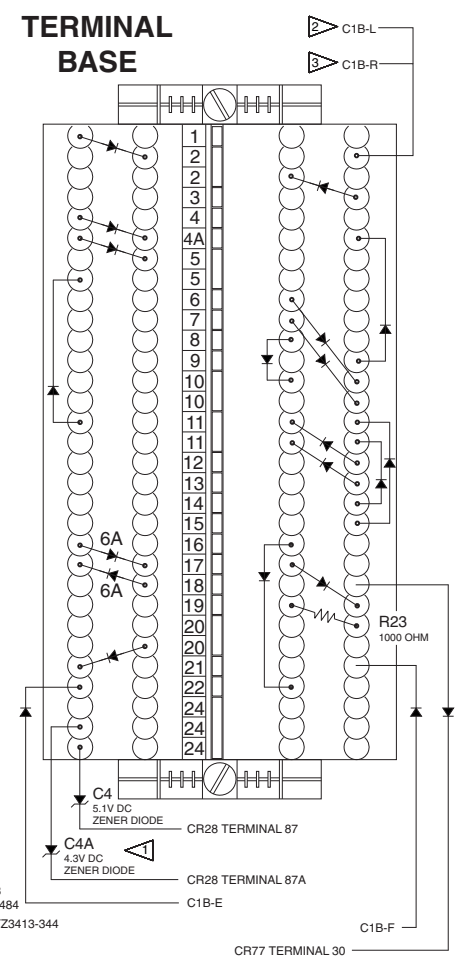
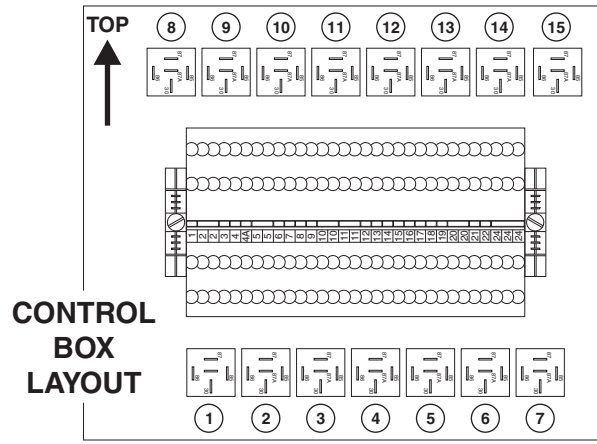
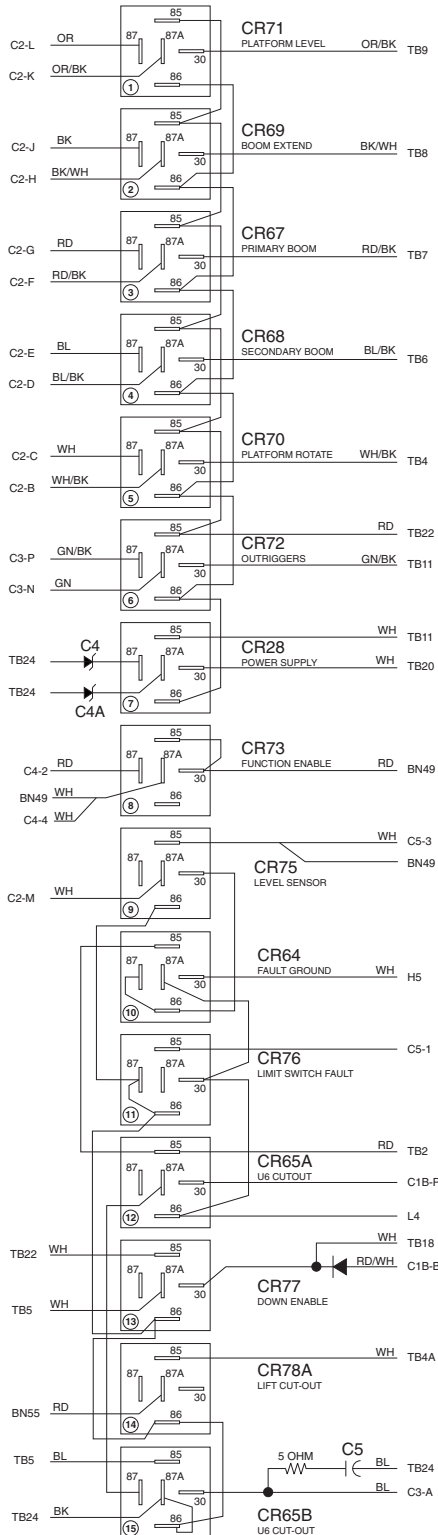

ES0441G

- 1 3.3V DC TO TZ3406-483
- 2 4.3V DC FROM TZ3406-484
- 3 FROM TZ3410-145 TO TZ3413-344
- 3 FROM TZ3413-345

Platform Control Box Wiring Diagram - AS/CE

(to serial number TZ3404-303)

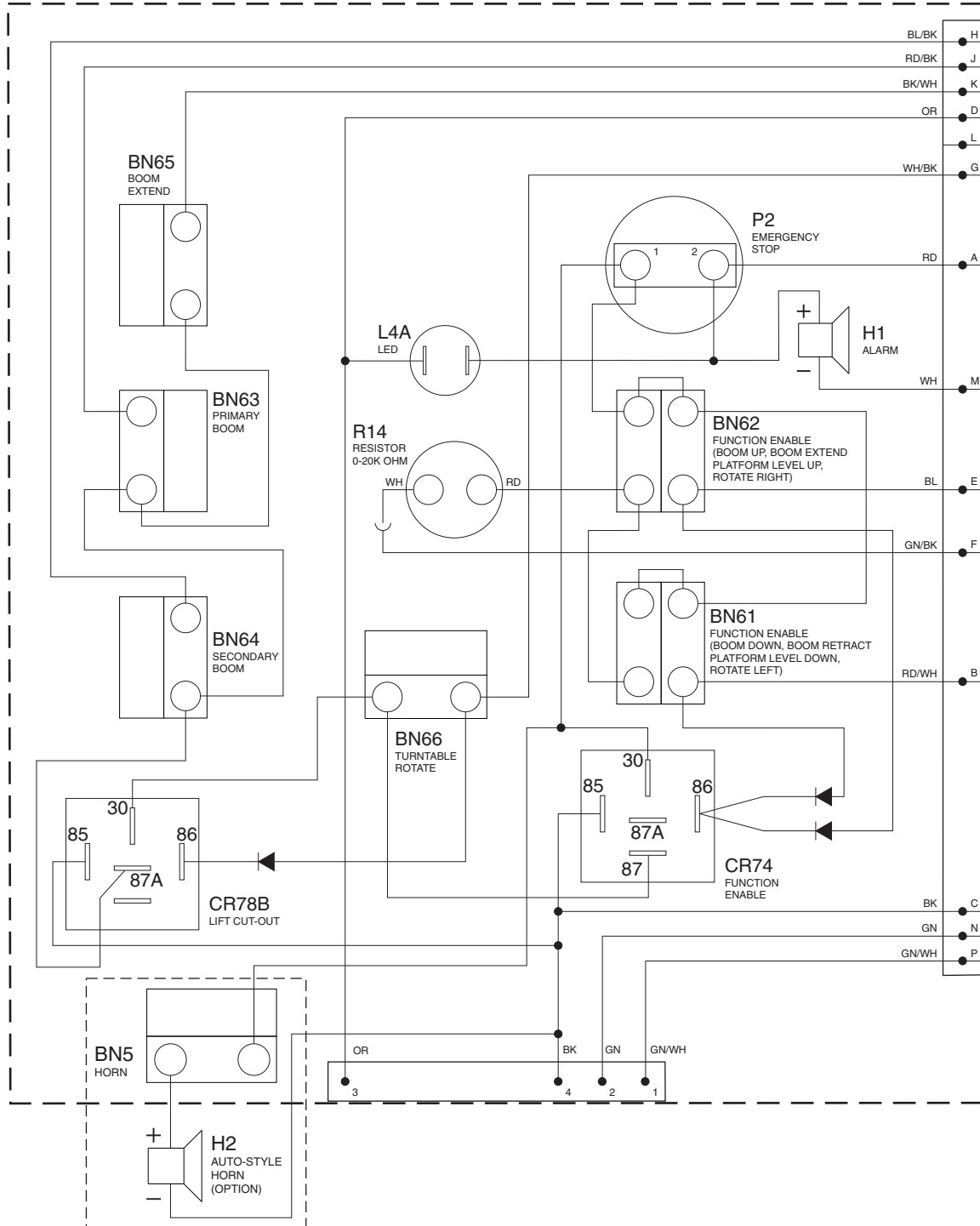

Platform Control Box Wiring Diagram - AS/CE (from serial number TZ3404-304 to TZ3406-204)

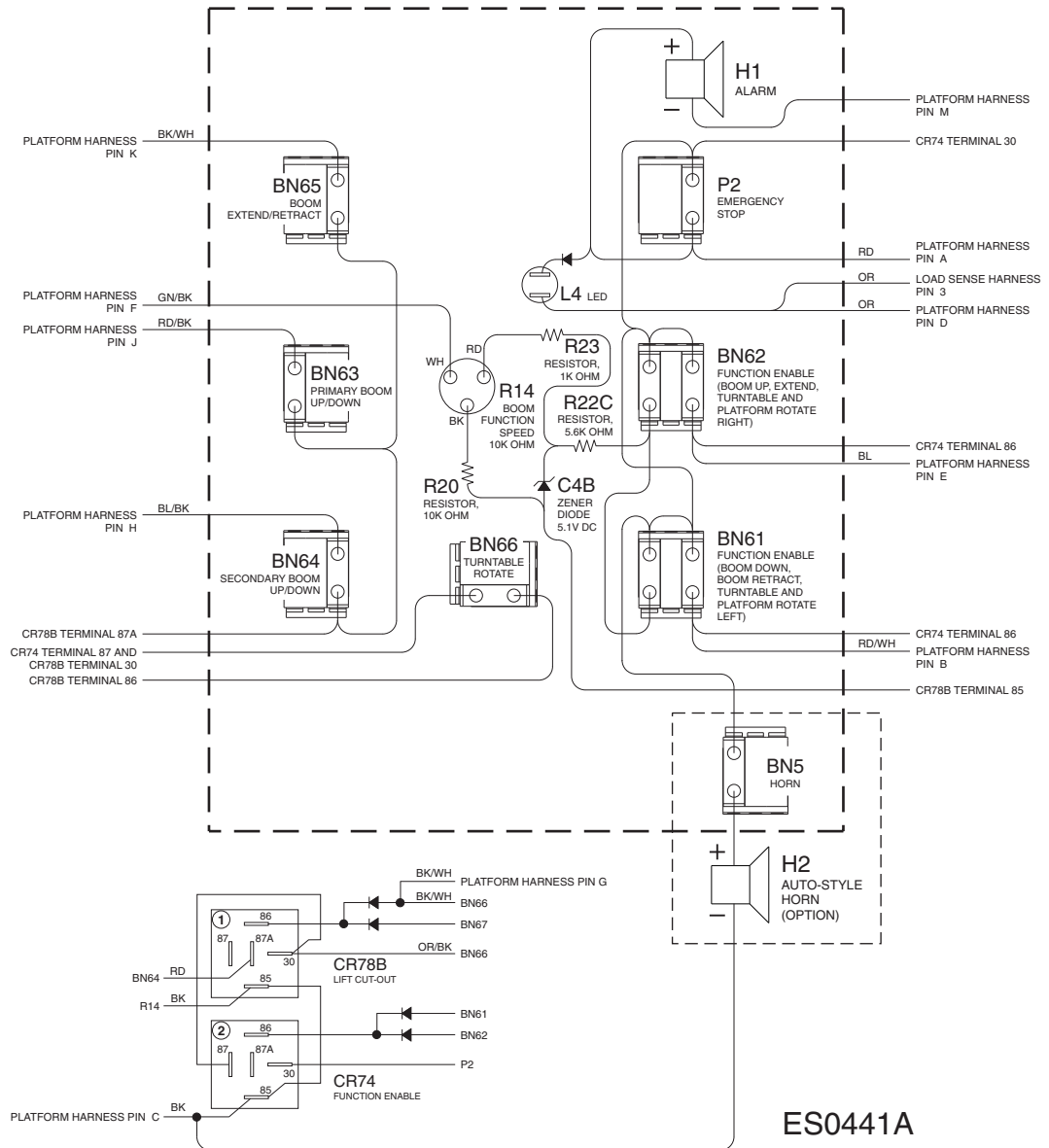

Platform Control Box Wiring Diagram - AS/CE

(from serial number TZ3406-205 to TZ3410-144)

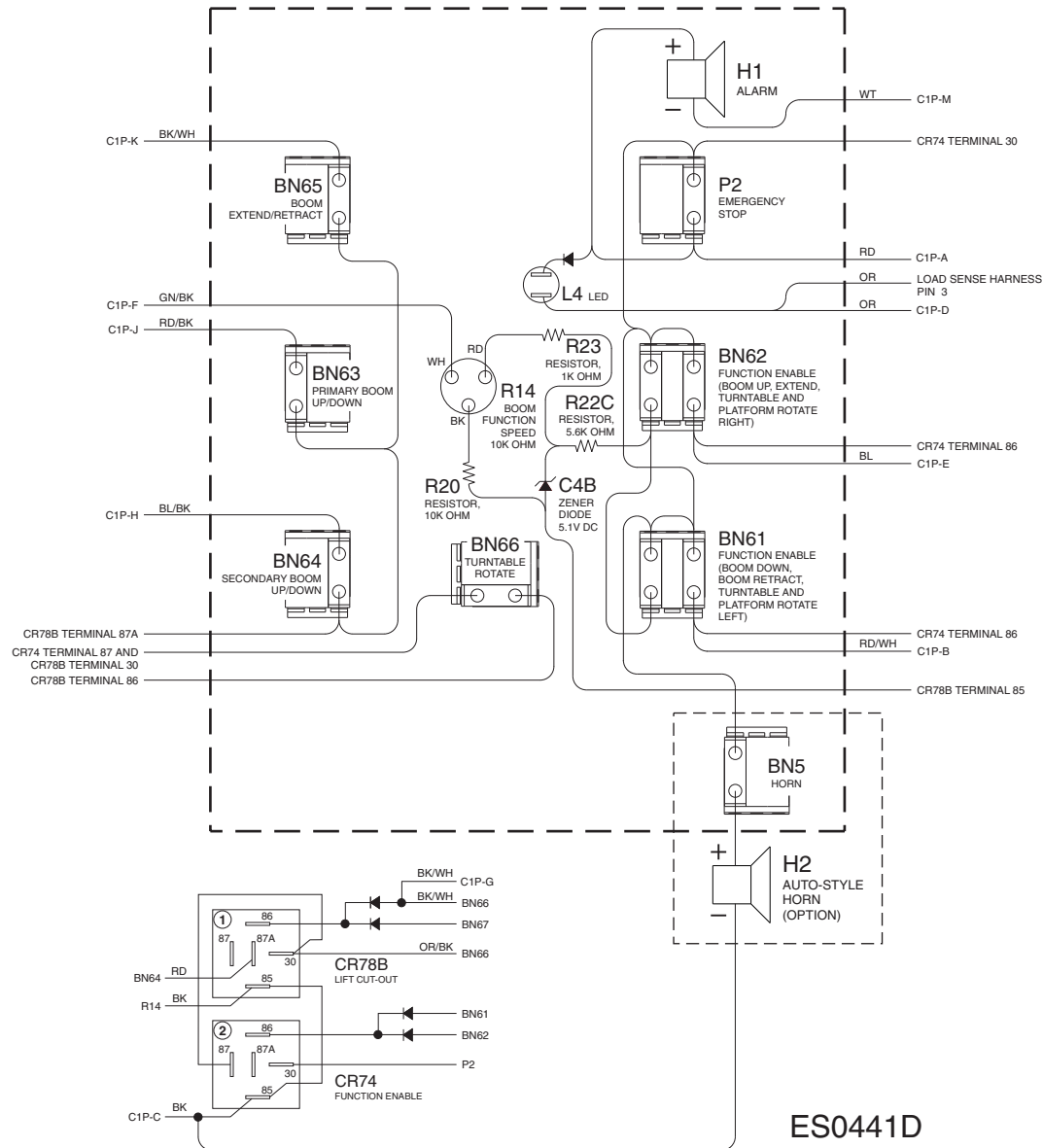

Platform Control Box Wiring Diagram - AS/CE (from serial number TZ3410-145)

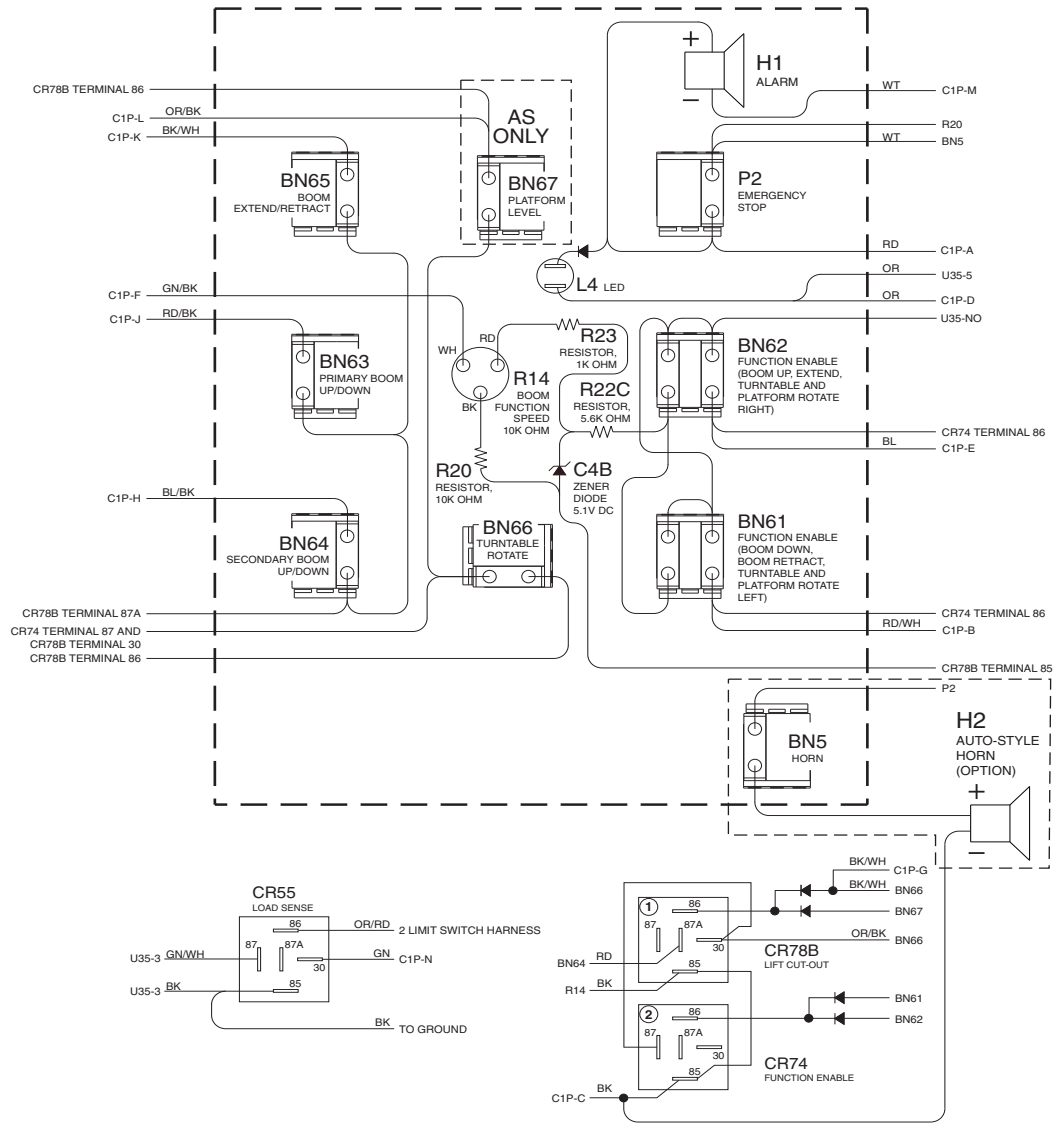

ES0441G

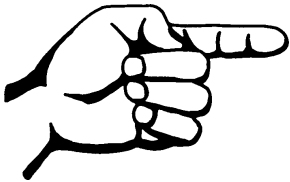

This page intentionally left blank.

**Electrical Schematic - ANSI/CSA
(to serial number TZ3403-185)**

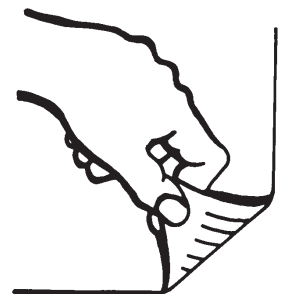
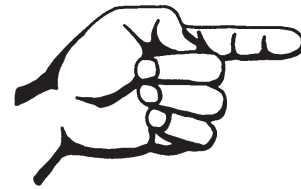

Electrical Schematic - ANSI/CSA (to serial number TZ3403-185)

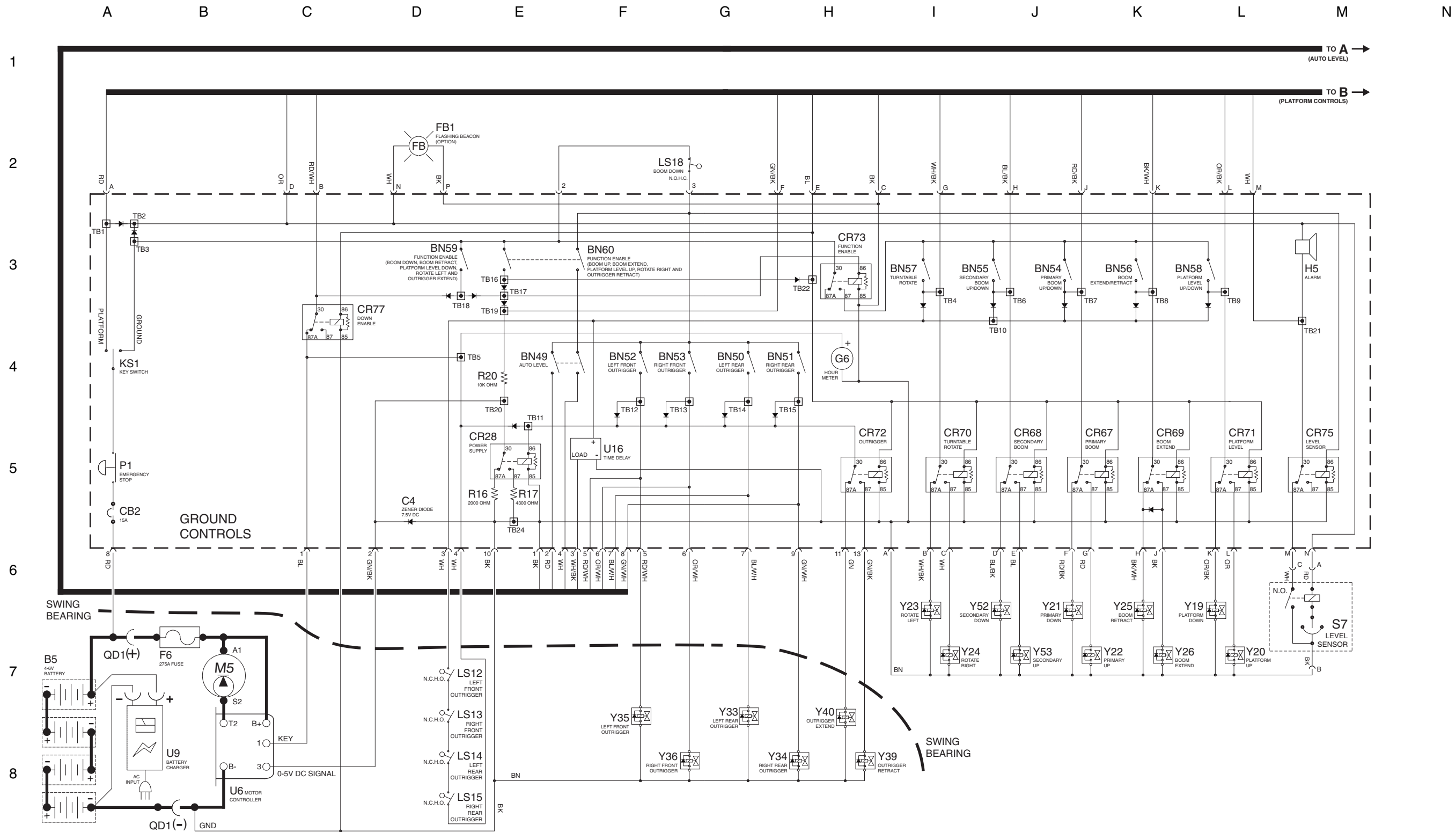

Electrical Schematic - ANSI/CSA (to serial number TZ3403-185)

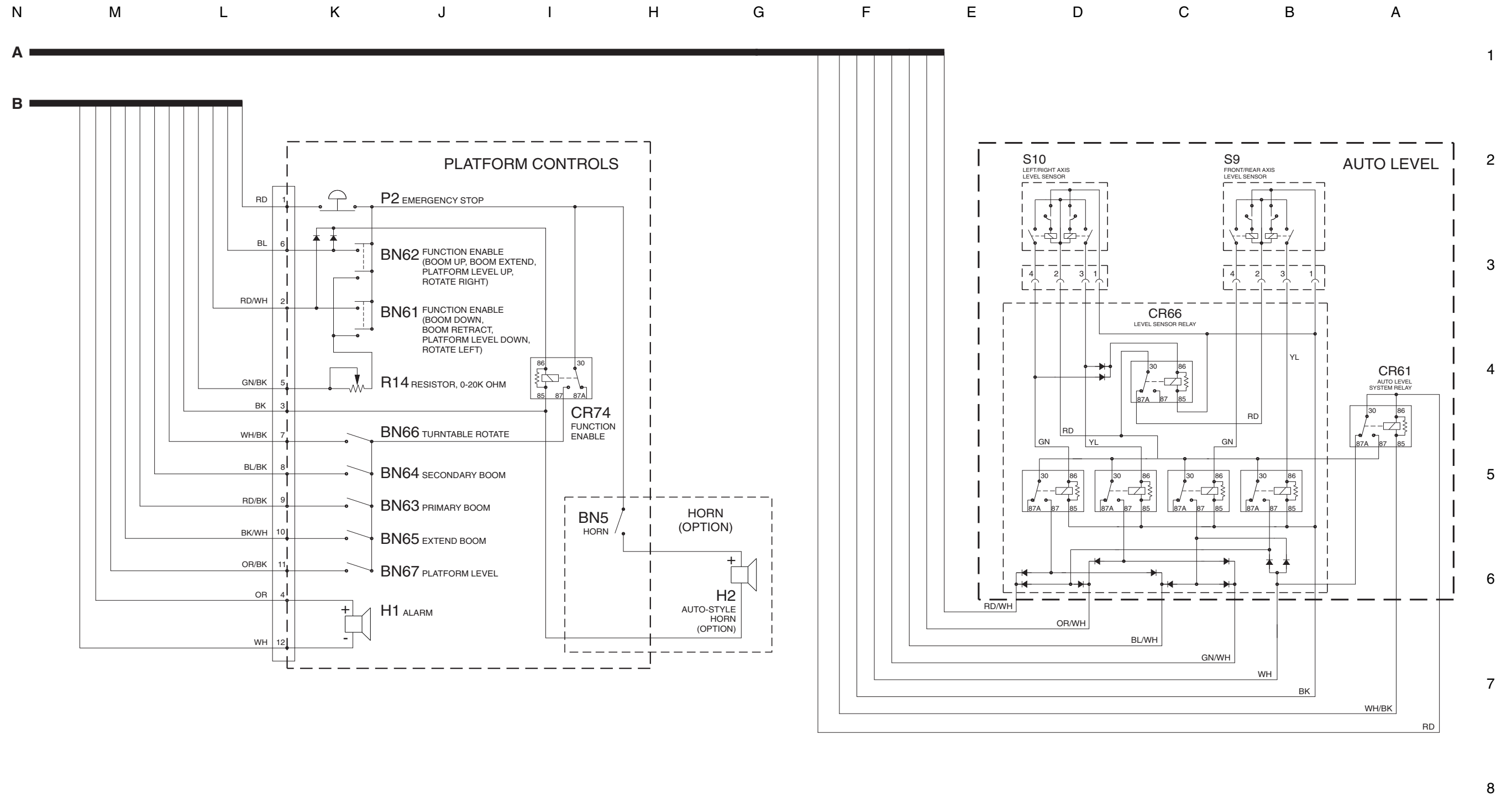

**Electrical Schematic - ANSI/CSA
(to serial number TZ3403-185)**

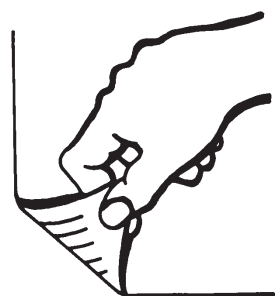

**Electrical Schematic - ANSI/CSA
(from serial number TZ3403-186 to TZ3403-248)**

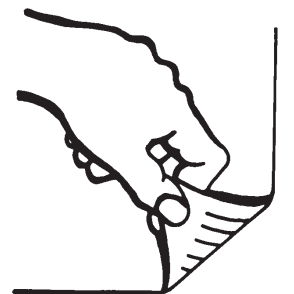
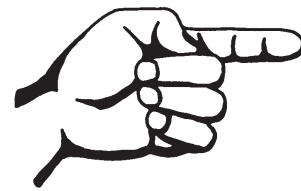

Electrical Schematic - ANSI/CSA (from serial number TZ3403-186 to TZ3403-248)

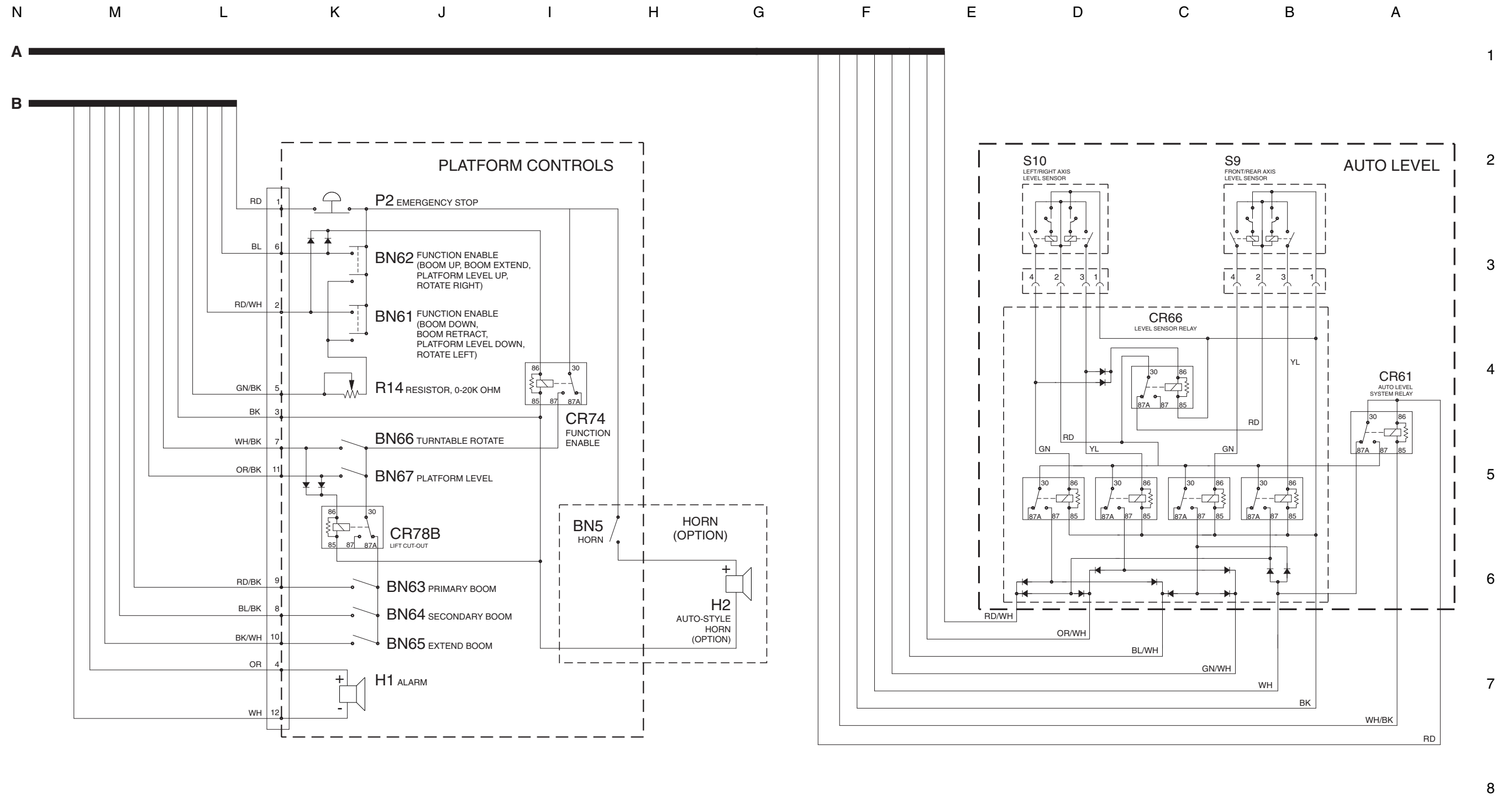

Electrical Schematic - ANSI/CSA
(from serial number TZ3403-186 to TZ3403-248)

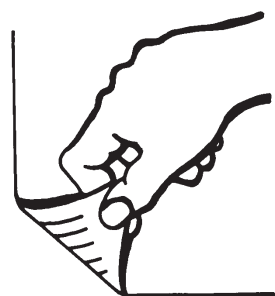

**Electrical Schematic - ANSI/CSA
(from serial number TZ3403-249 to TZ3404-303)**

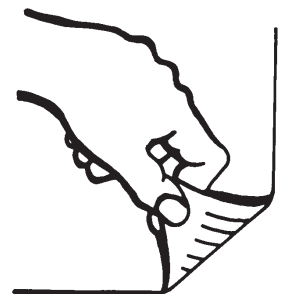
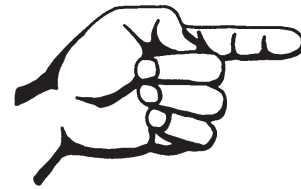

Electrical Schematic - ANSI/CSA (from serial number TZ3403-249 to TZ3404-303)

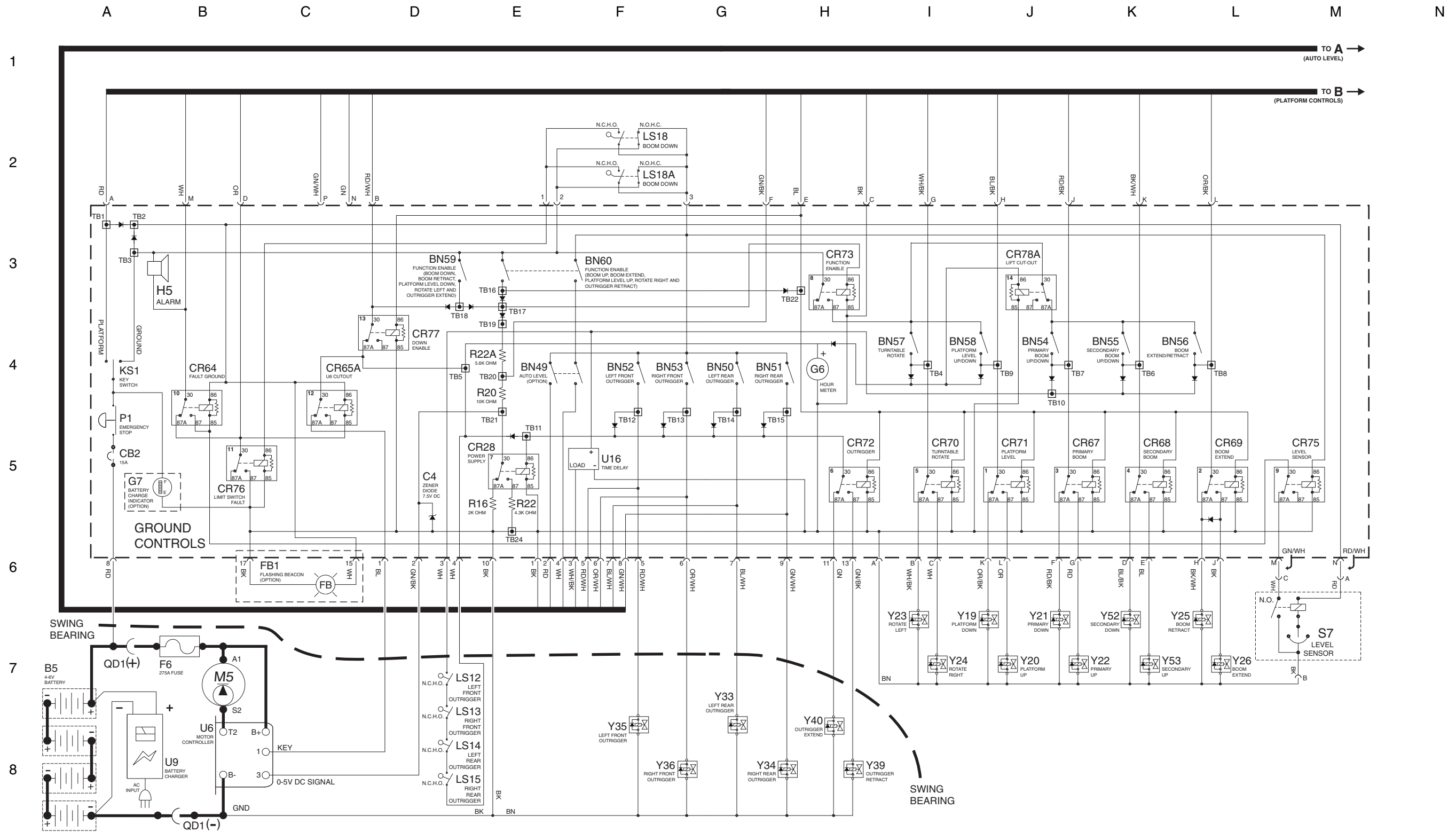

Electrical Schematic - ANSI/CSA (from serial number TZ3403-249 to TZ3404-303)

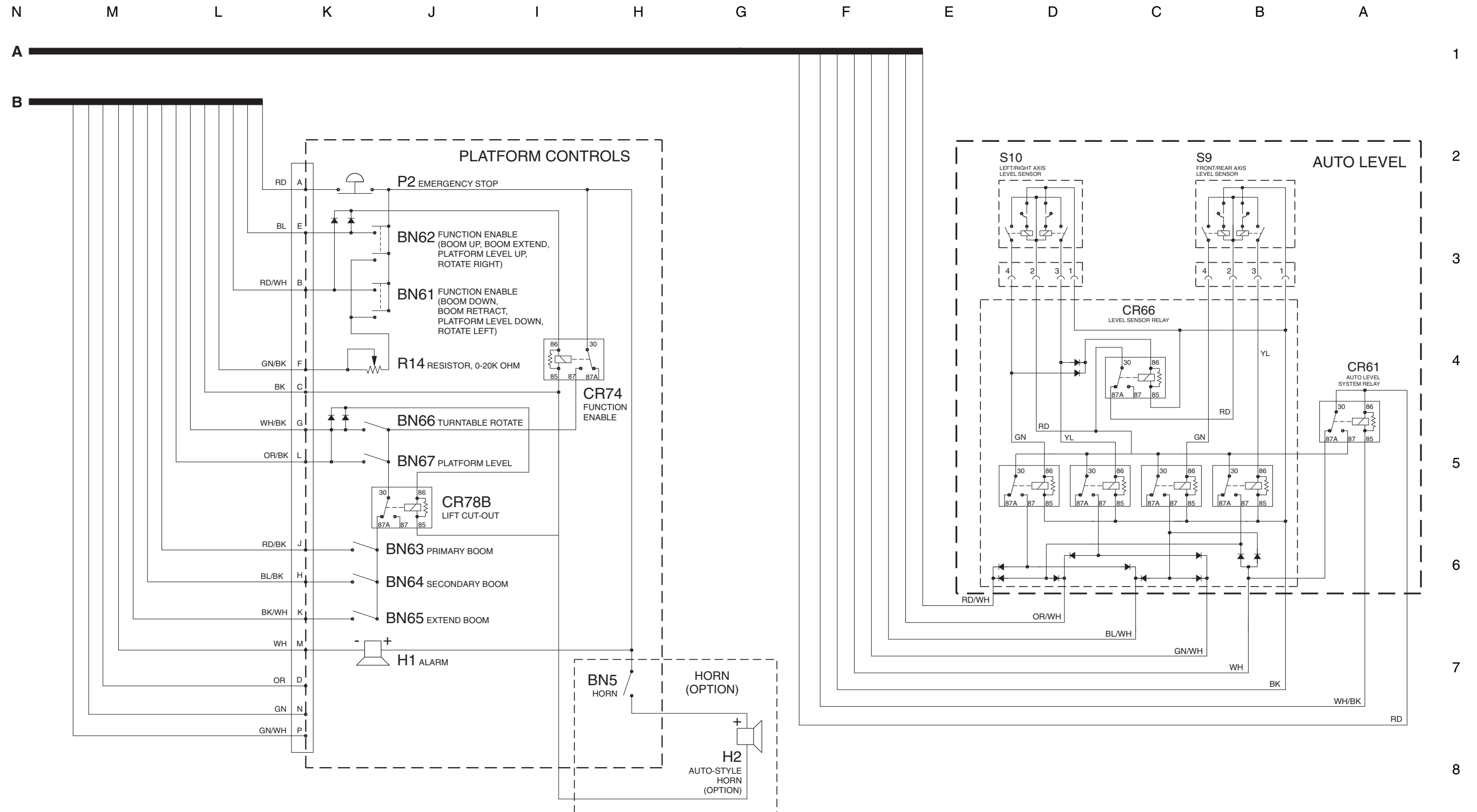

Electrical Schematic - ANSI/CSA
(from serial number TZ3403-249 to TZ3404-303)

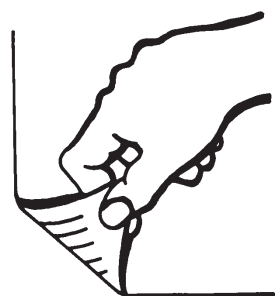

**Electrical Schematic - ANSI/CSA
(from serial number TZ3404-304 to TZ3405-189)**

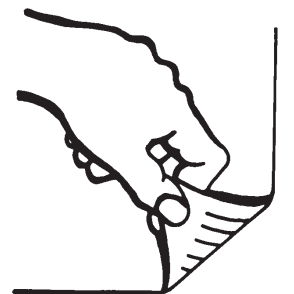

Electrical Schematic - ANSI/CSA (from serial number TZ3404-304 to TZ3405-189)

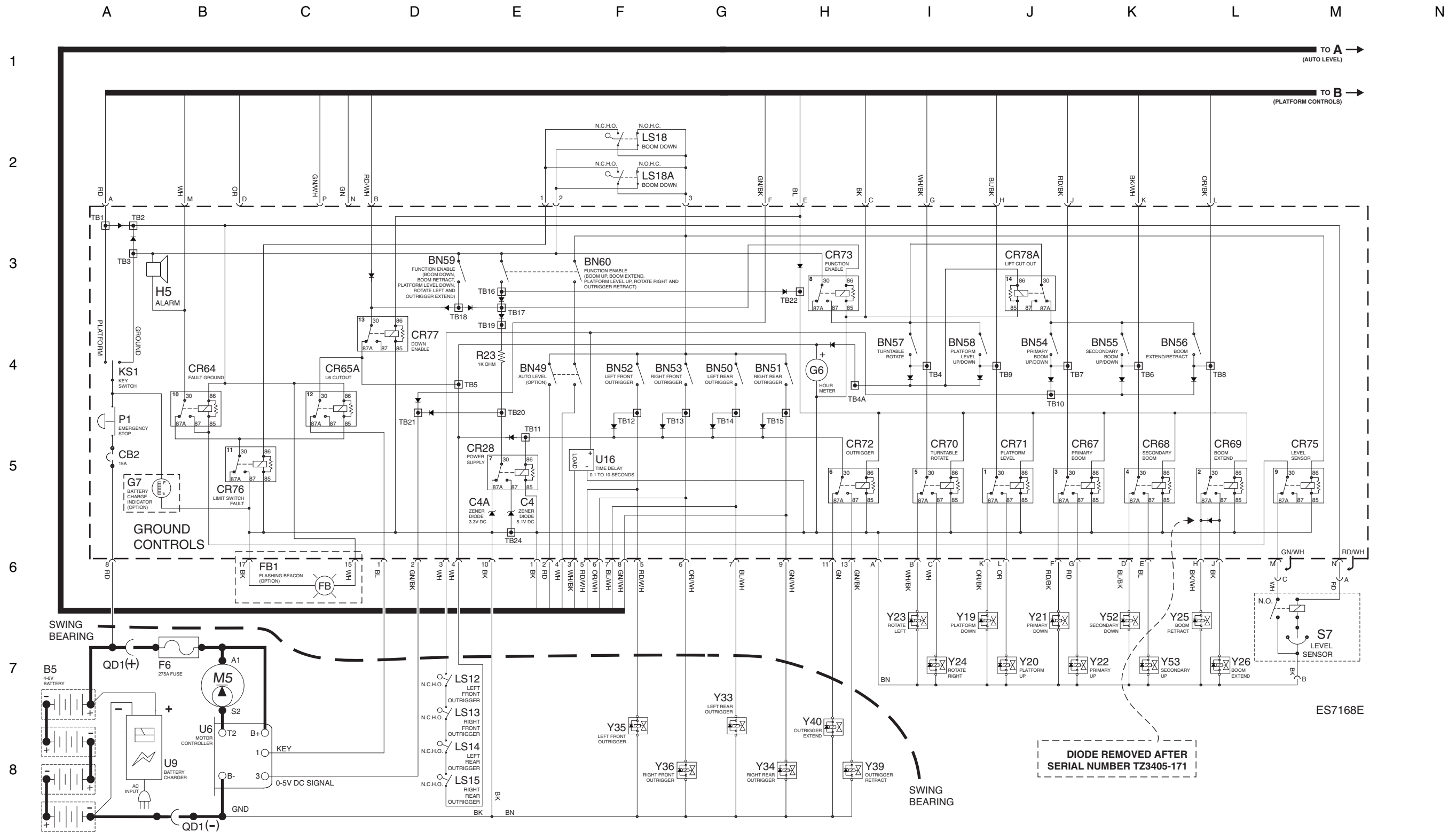

Electrical Schematic - ANSI/CSA (from serial number TZ3404-304 to TZ3405-189)

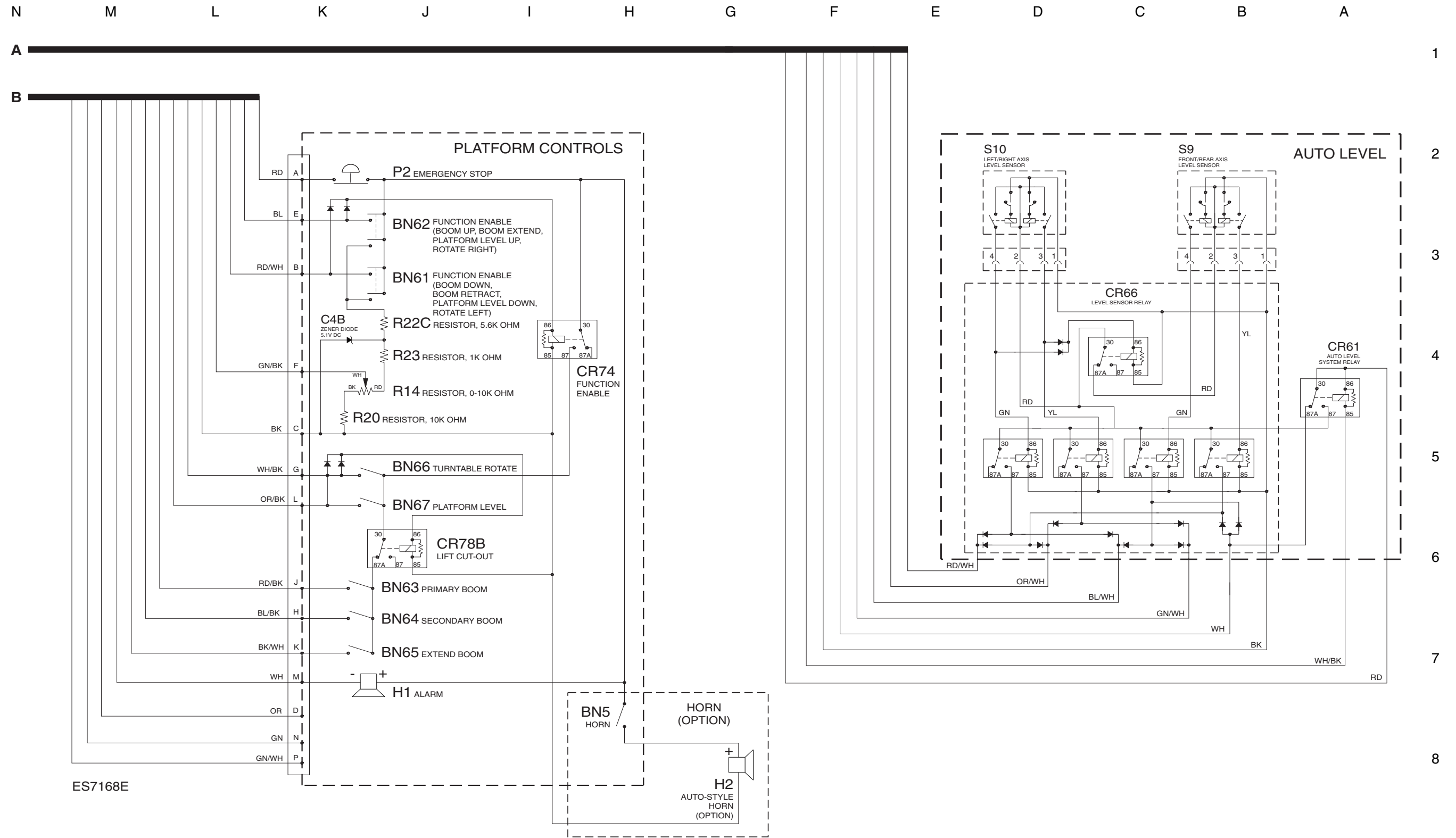

Electrical Schematic - ANSI/CSA
(from serial number TZ3404-304 to TZ3405-189)

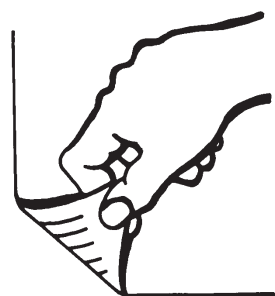

**Electrical Schematic - ANSI/CSA
(from serial number TZ3405-190 to TZ3406-204)**

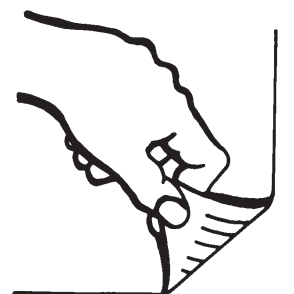
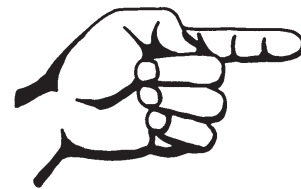

Electrical Schematic - ANSI/CSA (from serial number TZ3405-190 to TZ3406-204)

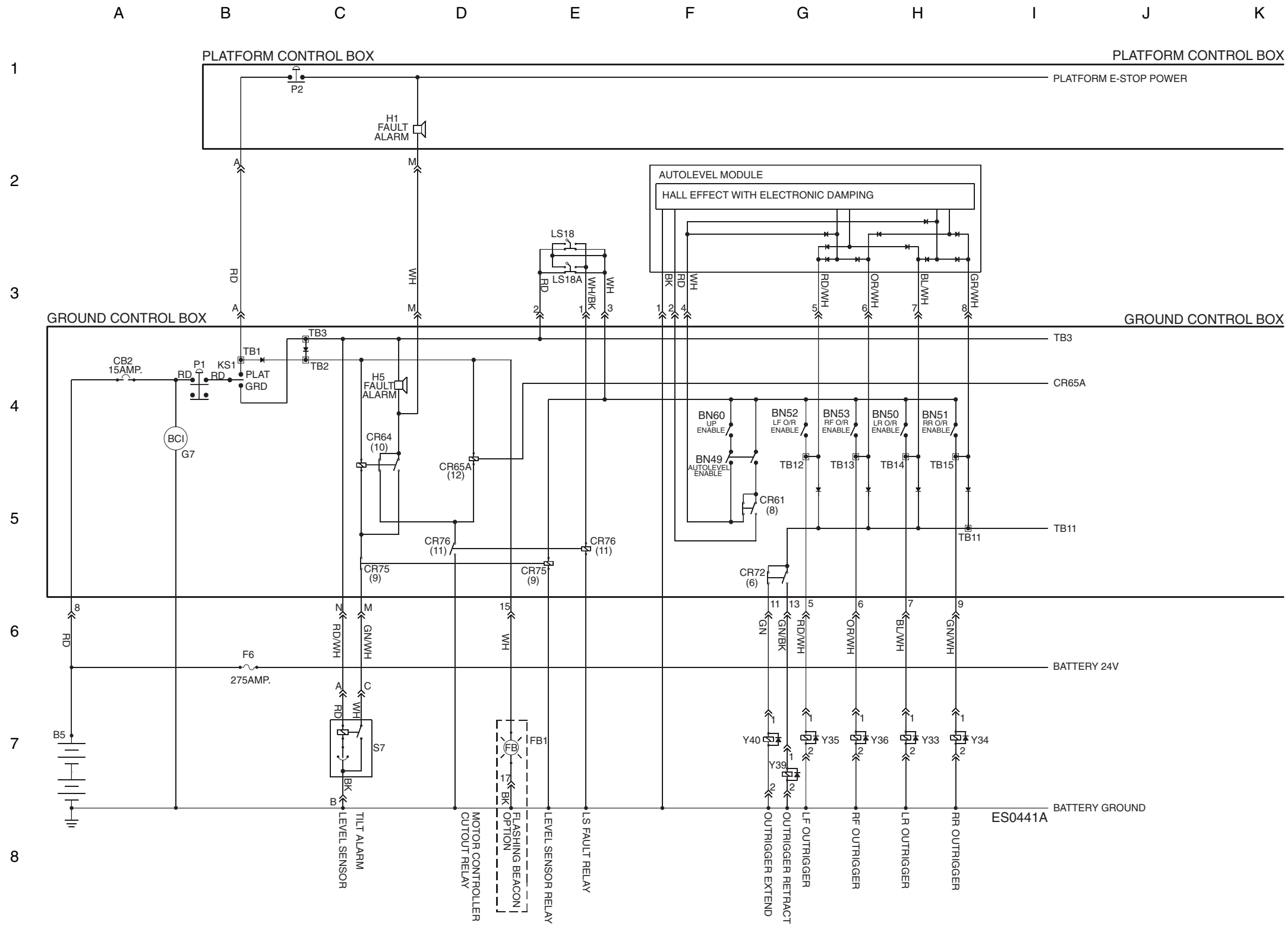

Electrical Schematic - ANSI/CSA (from serial number TZ3405-190 to TZ3406-204)

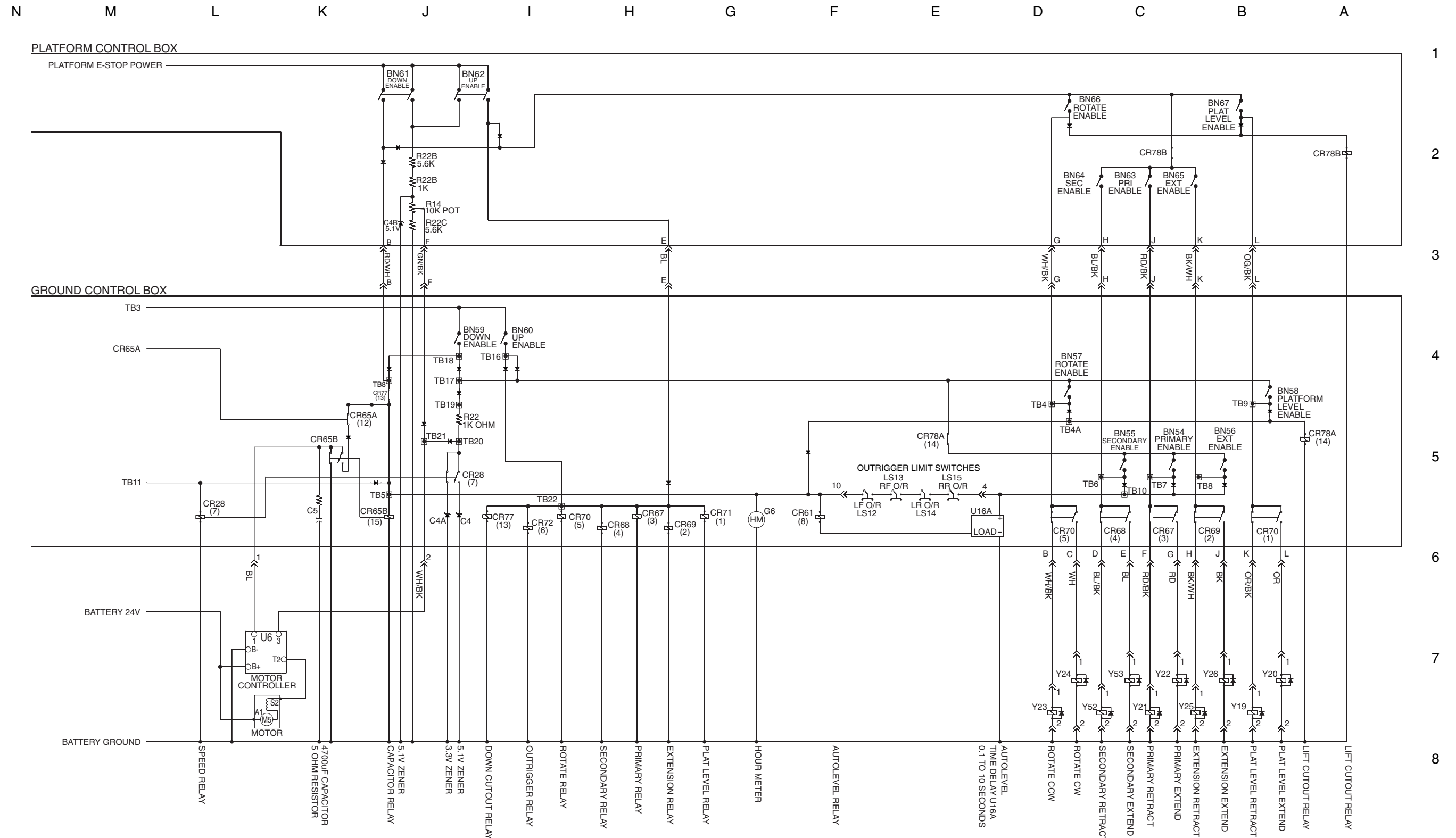

ES0441A

Electrical Schematic - ANSI/CSA
(from serial number TZ3405-190 to TZ3406-204)

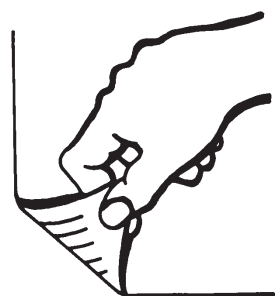

**Electrical Schematic - ANSI/CSA
(from serial number TZ3406-205 to TZ3411-358)**

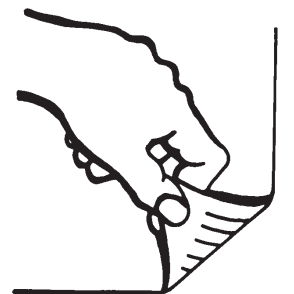
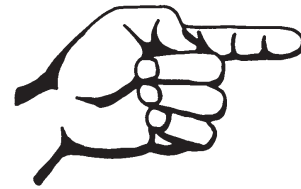

Electrical Schematic - ANSI/CSA (from serial number TZ3406-205 to TZ3411-358)

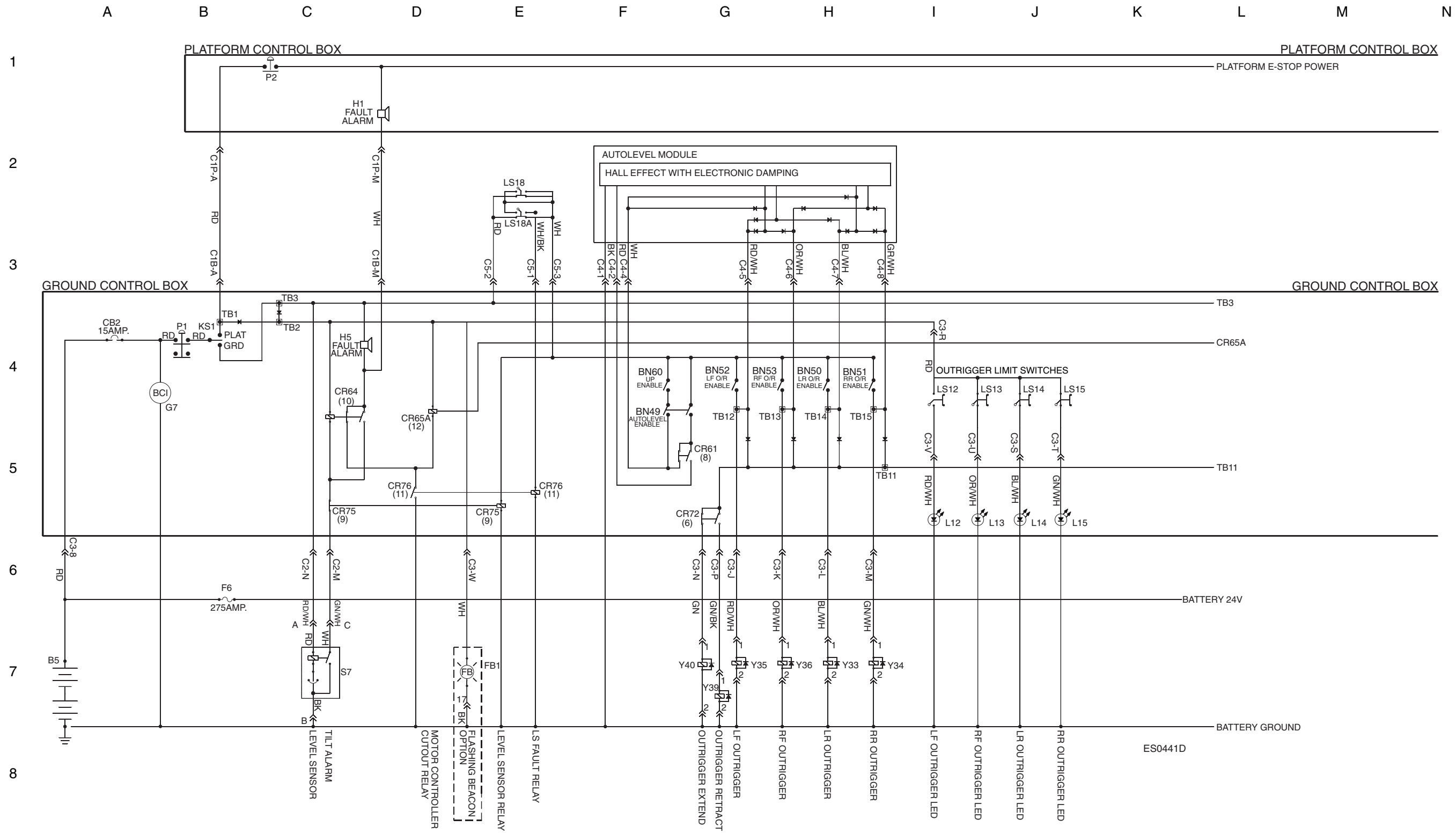

Electrical Schematic - ANSI/CSA
(from serial number TZ3406-205 to TZ3411-358)

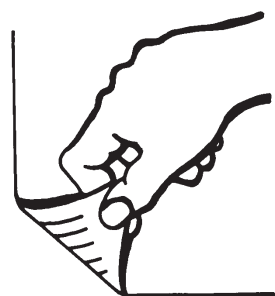

**Electrical Schematic - ANSI/CSA
(from serial number TZ3411-359 to TZ3413-344)**

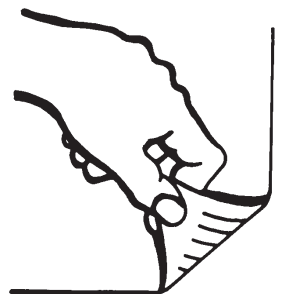
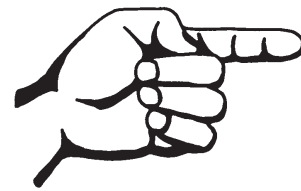

Electrical Schematic - ANSI/CSA (from serial number TZ3411-359 to TZ3413-344)

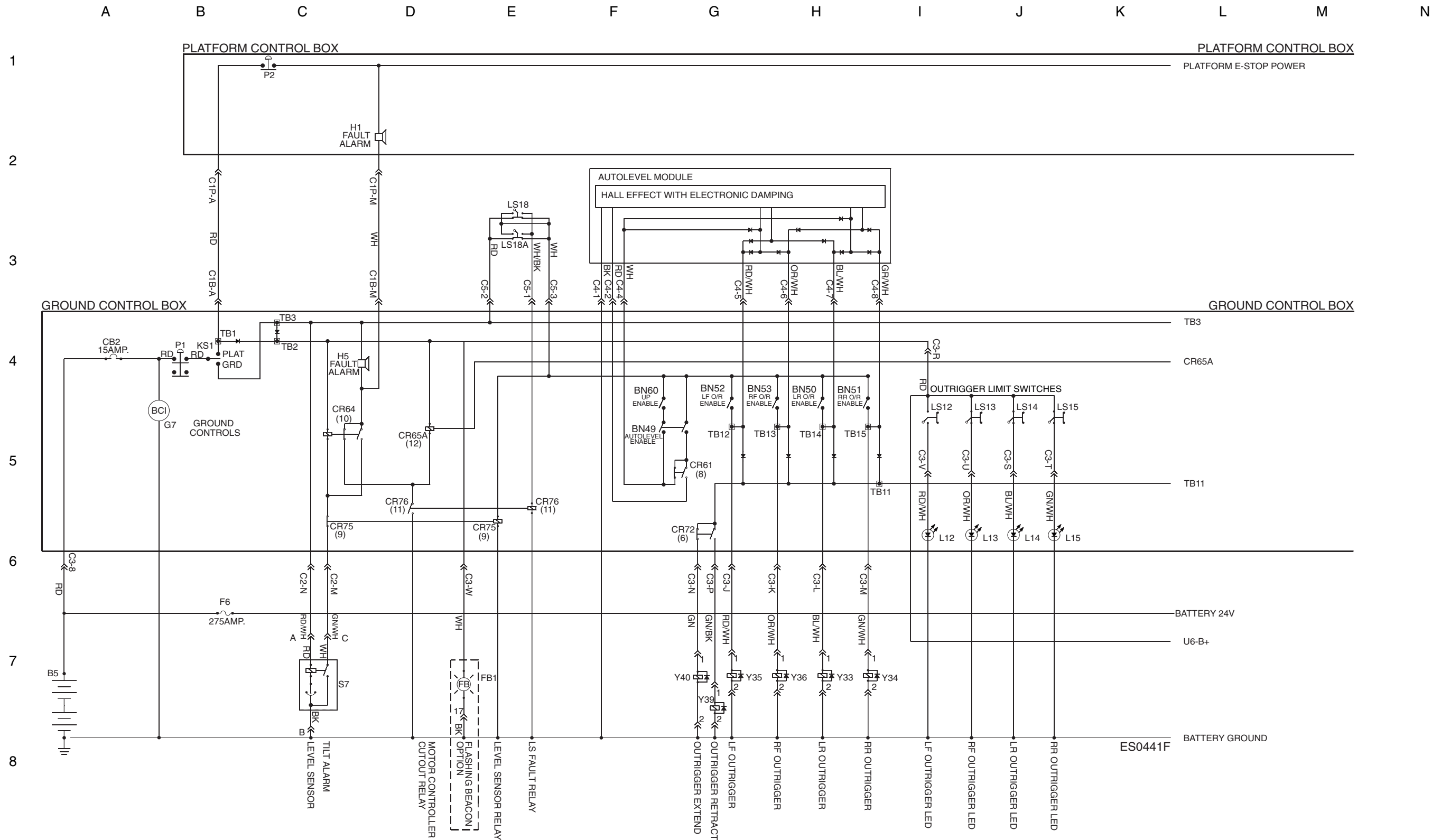

Electrical Schematic - ANSI/CSA
(from serial number TZ3411-359 to TZ3413-344)

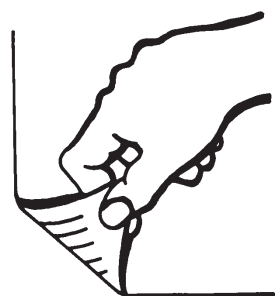

**Electrical Schematic - ANSI/CSA
(from serial number TZ3413-345)**

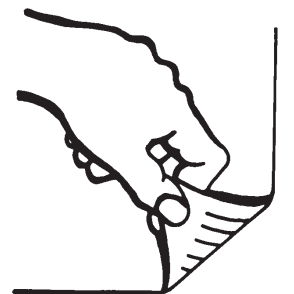
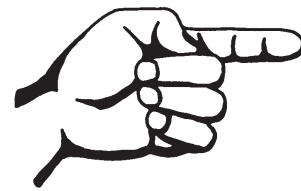

Electrical Schematic - ANSI/CSA (from serial number TZ3413-345)

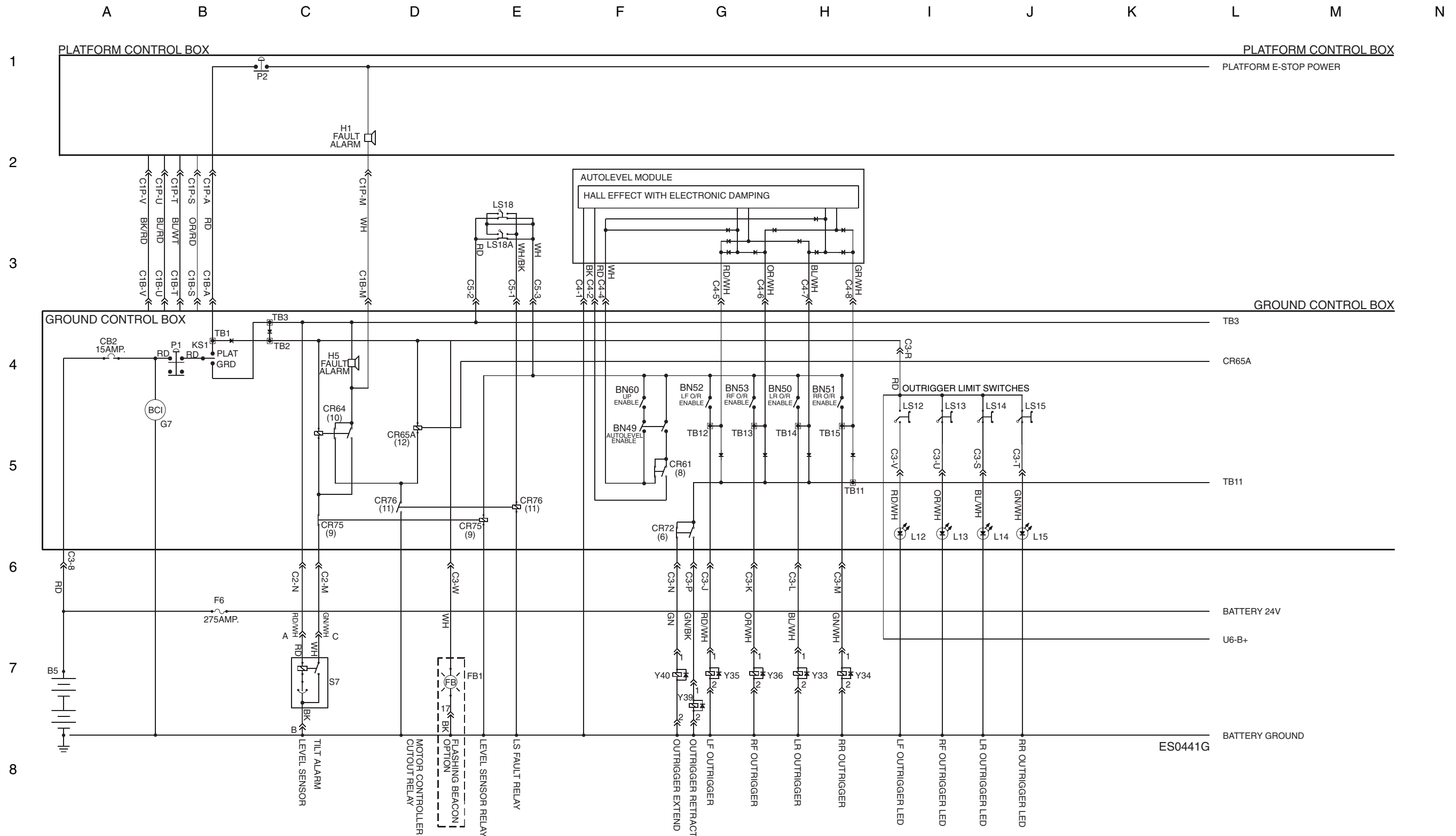

Electrical Schematic - ANSI/CSA (from serial number TZ3413-345)

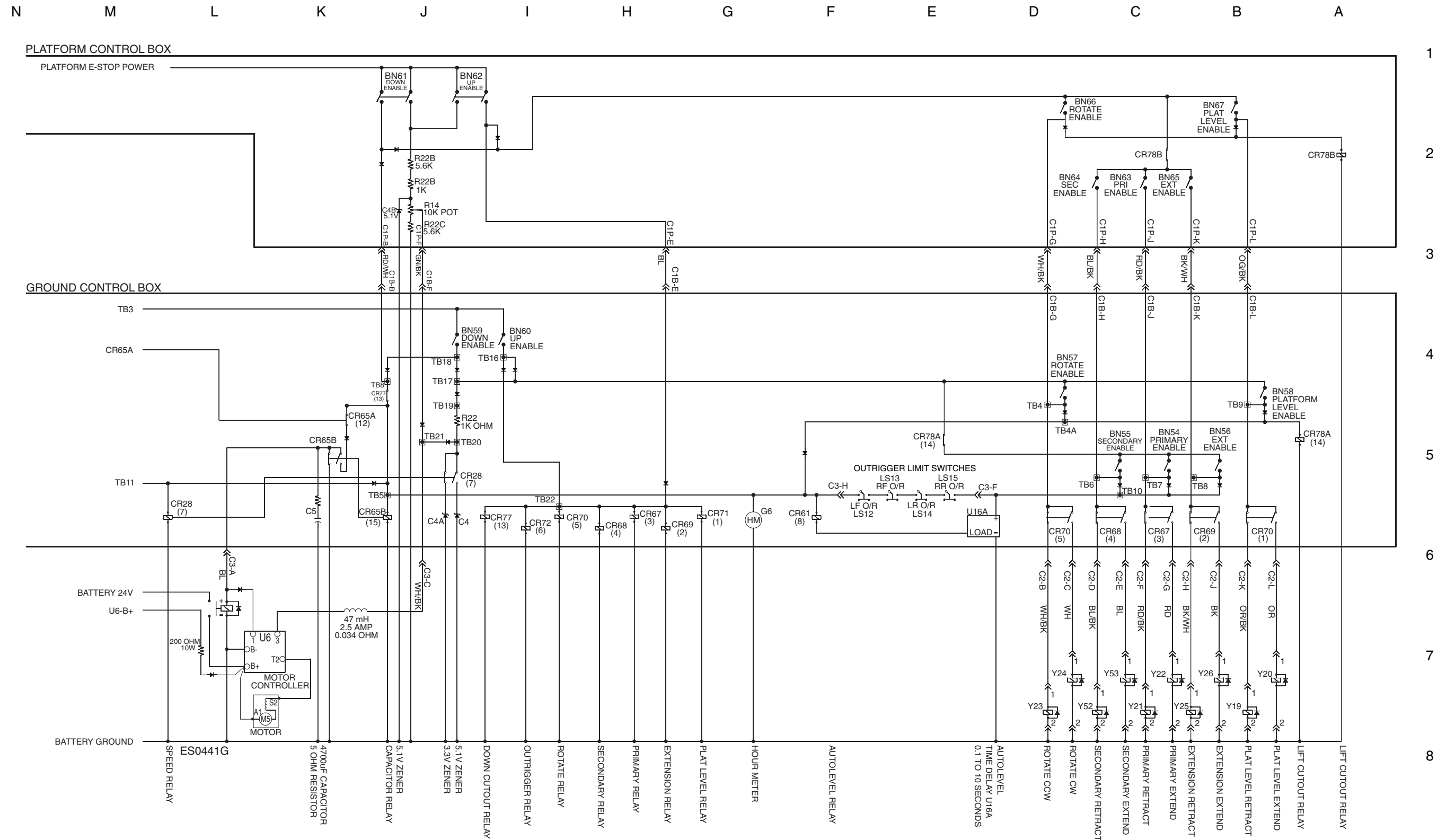

**Electrical Schematic - ANSI/CSA
(from serial number TZ3413-345)**

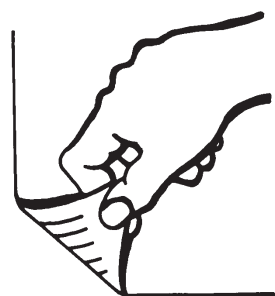

**Electrical Schematic - AS/CE
(to serial number TZ3404-303)**

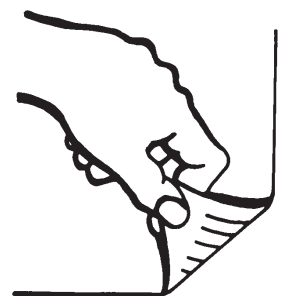
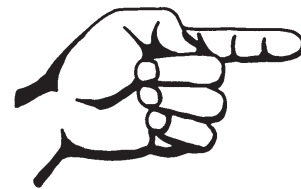

Electrical Schematic - AS/CE (to serial number TZ3404-303)

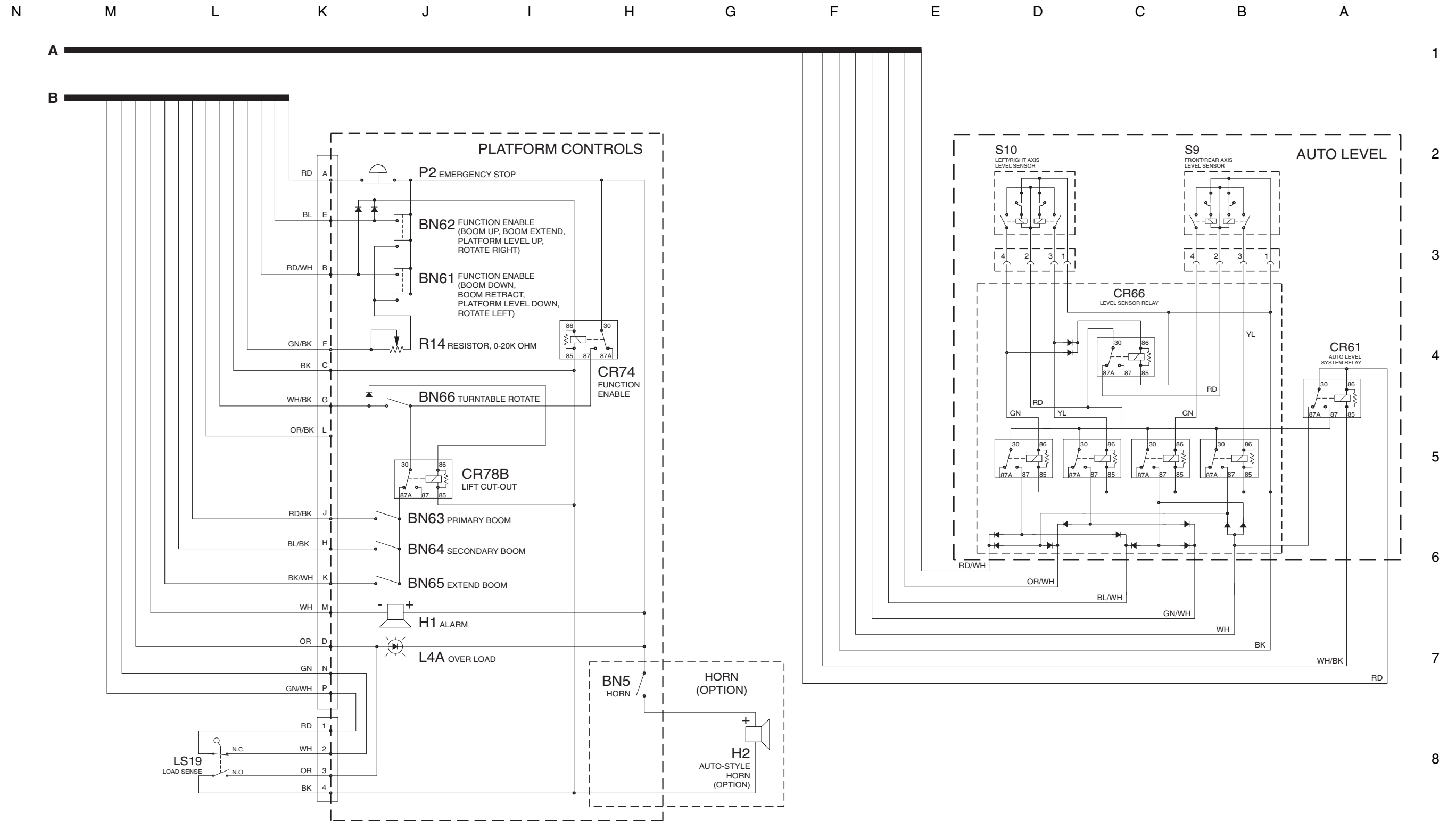

**Electrical Schematic - AS/CE
(to serial number TZ3404-303)**

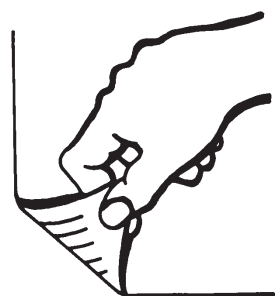

Electrical Schematic - AS/CE
(from serial number TZ3404-304 to TZ3405-189)

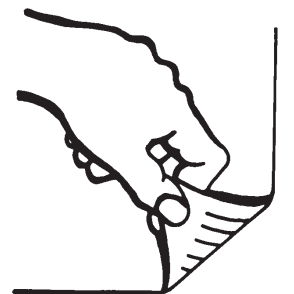
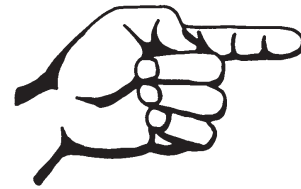

Electrical Schematic - AS/CE (from serial number TZ3404-304 to TZ3405-189)

N

M

L

K

J

I

H

G

F

E

D

C

B

A

A

B

1

2

3

4

5

6

7

8

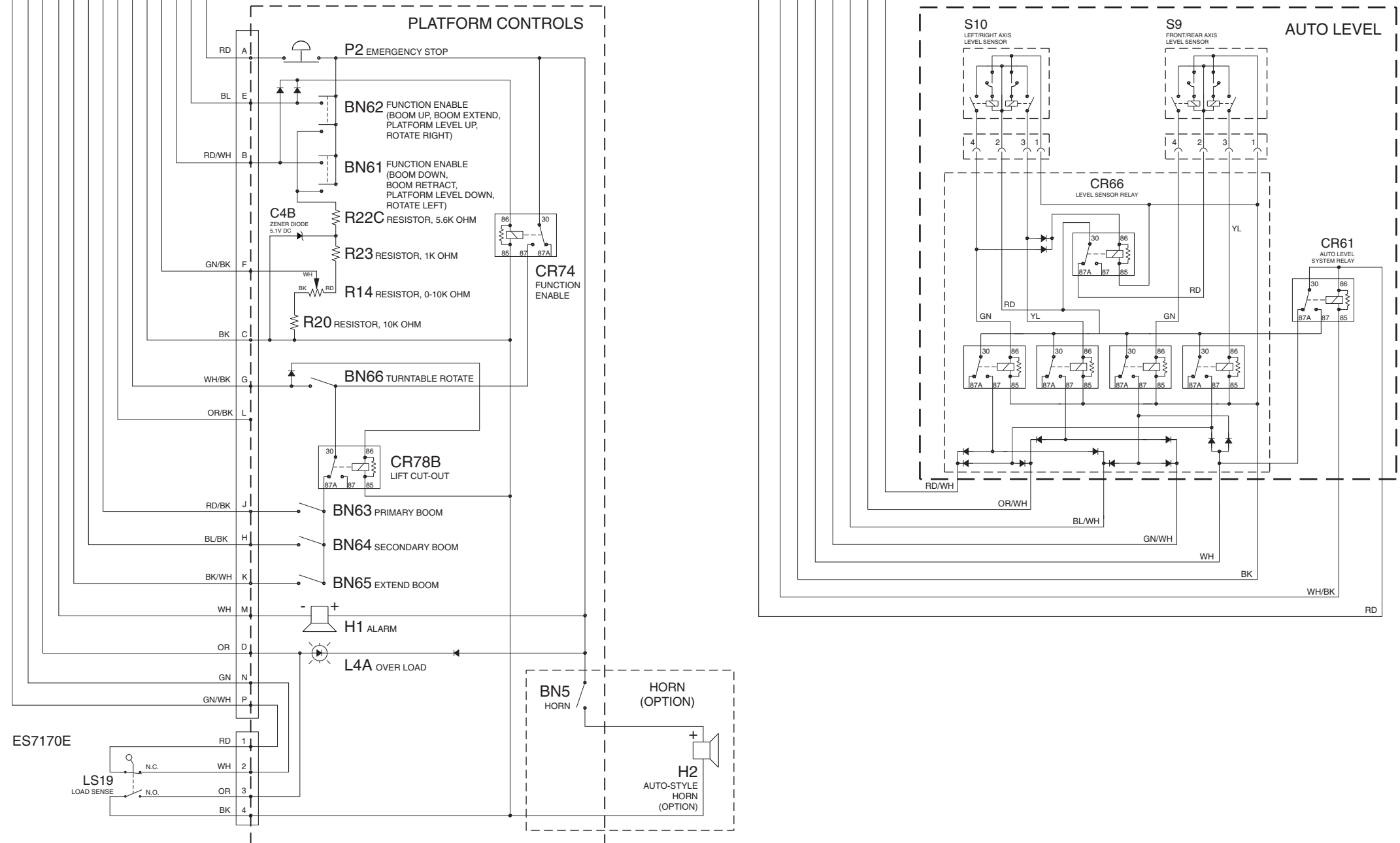

Electrical Schematic - AS/CE
(from serial number TZ3404-304 to TZ3405-189)

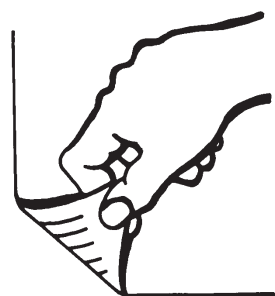

Electrical Schematic - AS/CE
(from serial number TZ3405-190 to TZ3406-204)

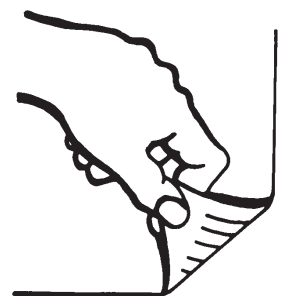
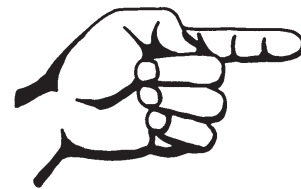

Electrical Schematic - AS/CE
(from serial number TZ3405-190 to TZ3406-204)

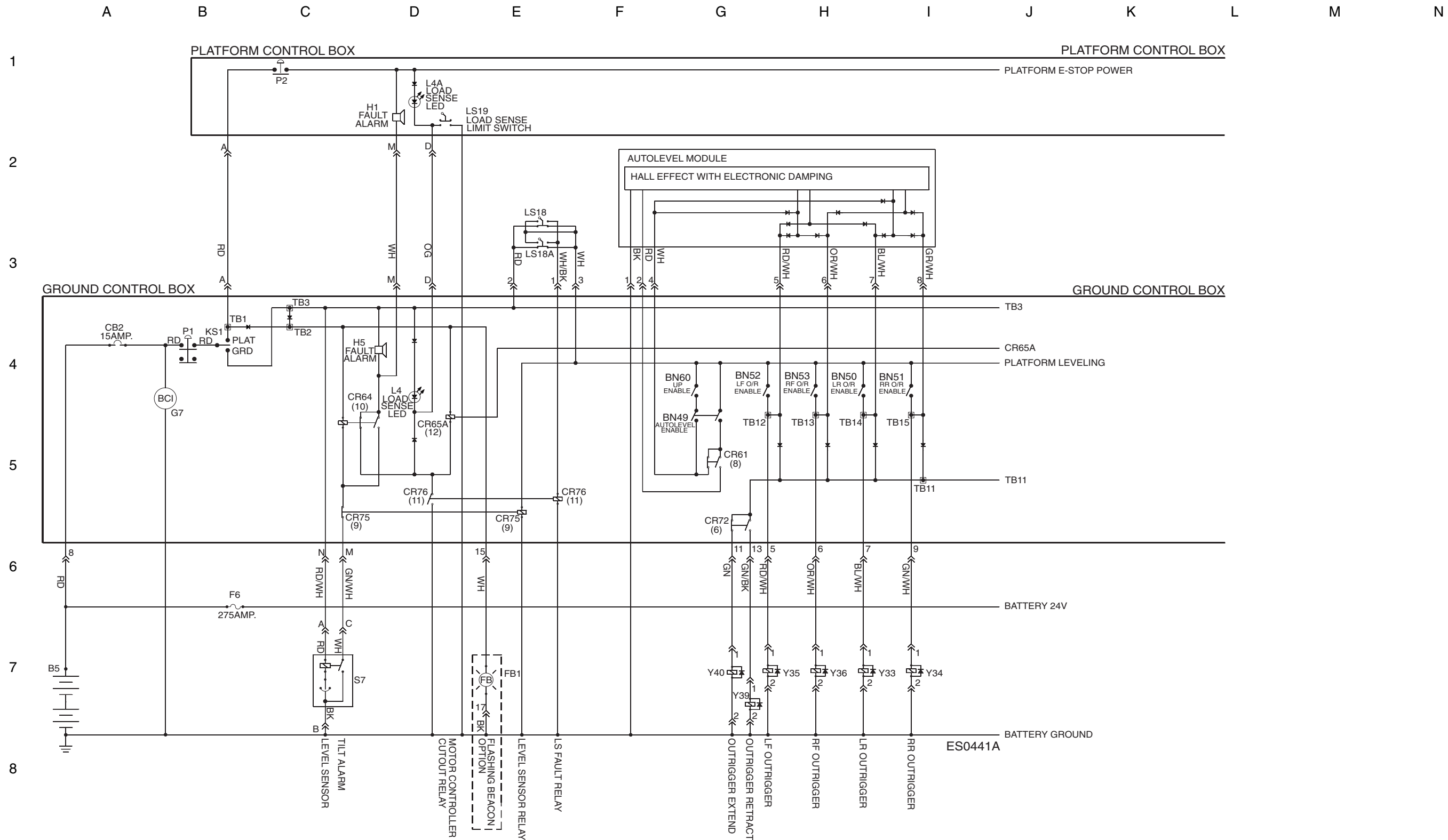

Electrical Schematic - AS/CE (from serial number TZ3405-190 to TZ3406-204)

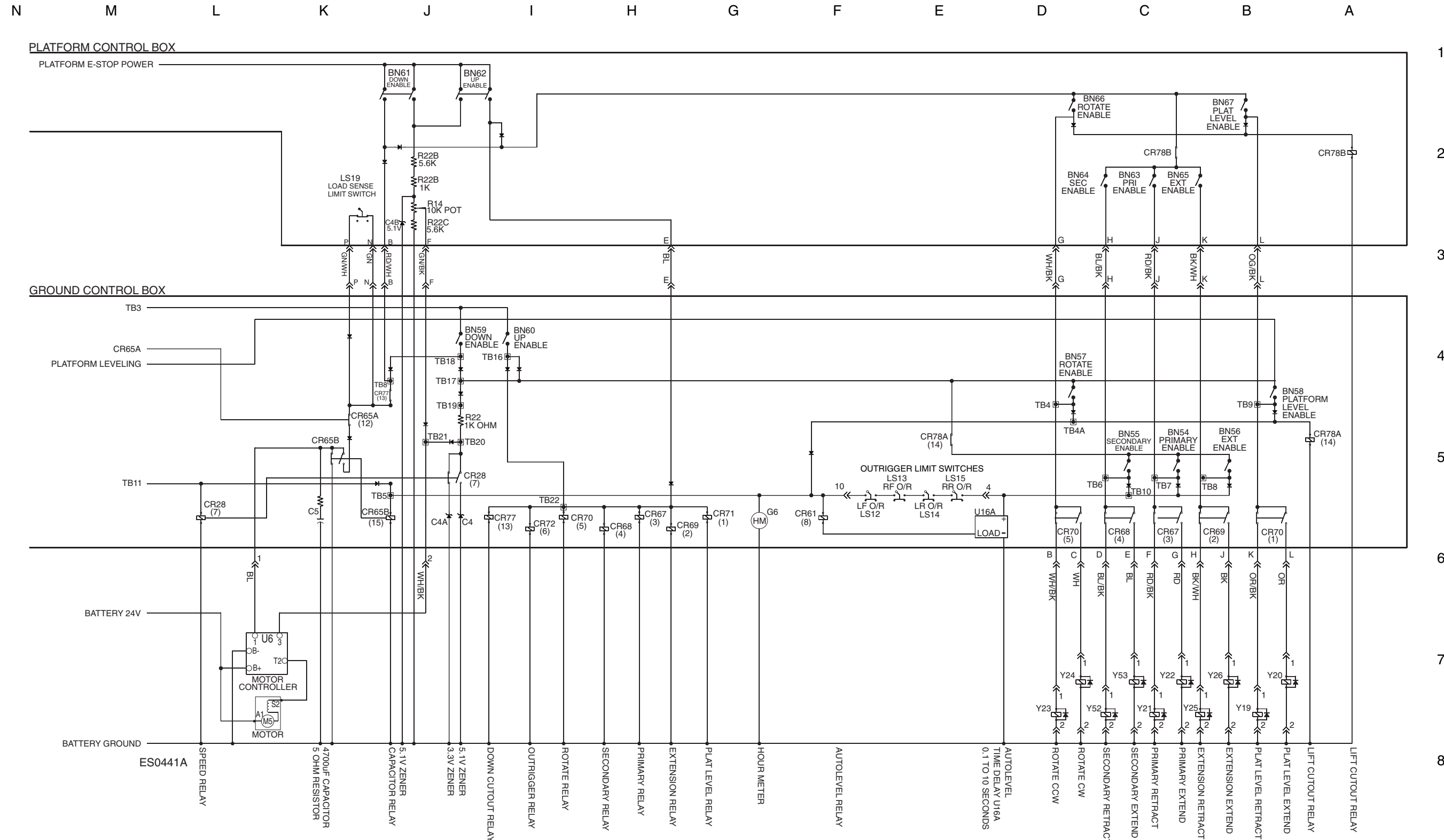

Electrical Schematic - AS/CE
(from serial number TZ3405-190 to TZ3406-204)

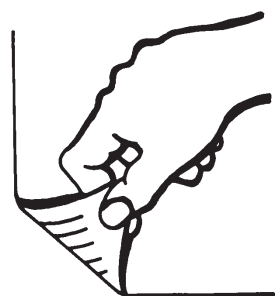

Electrical Schematic - AS/CE
(from serial number TZ3406-205 to TZ3411-358)

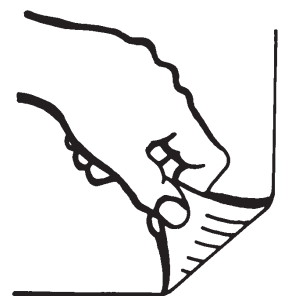
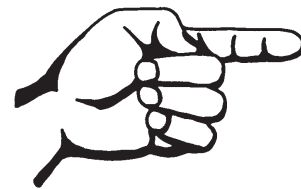

Electrical Schematic - AS/CE
(from serial number TZ3406-205 to TZ3411-358)

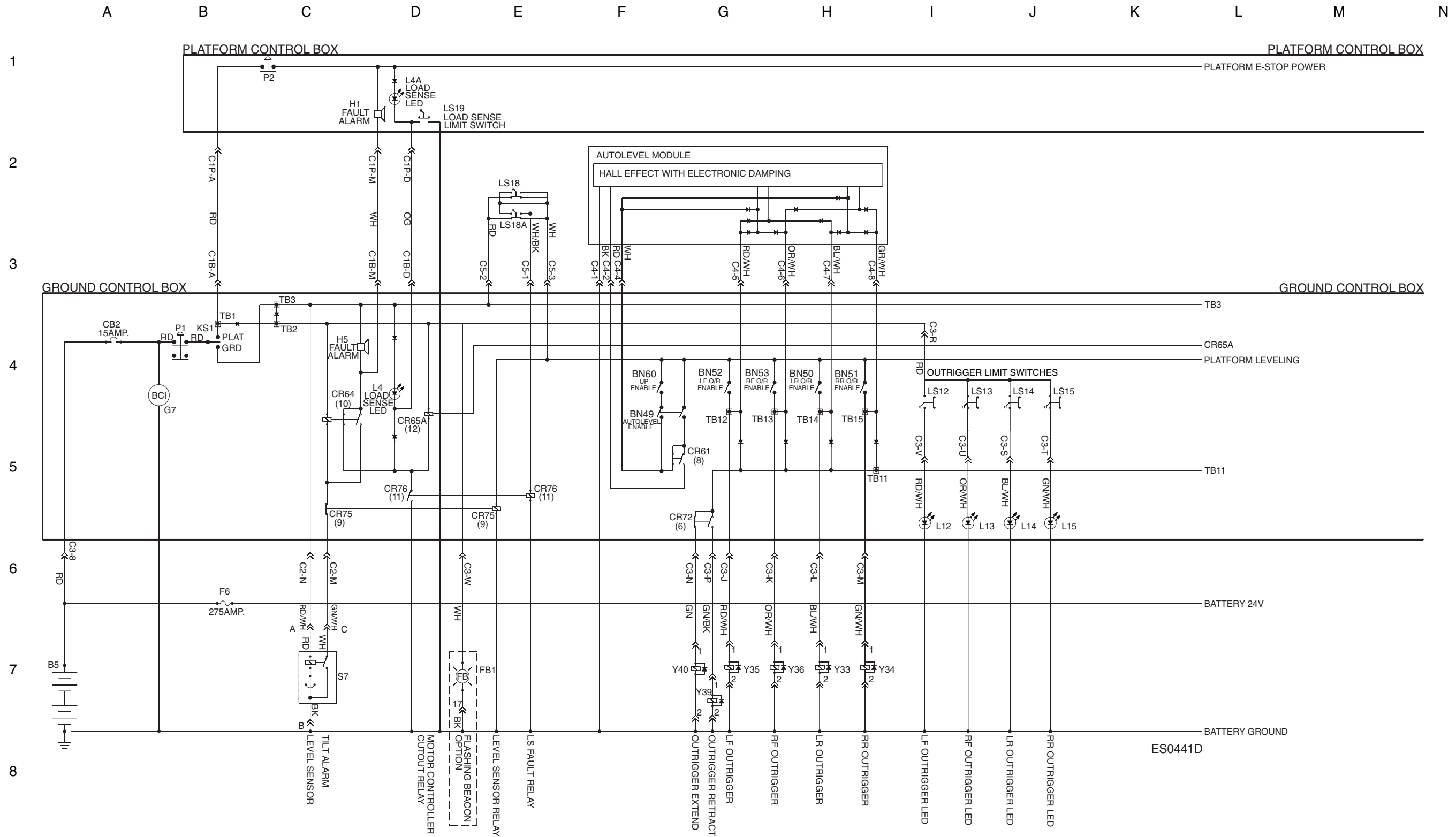

Electrical Schematic - AS/CE (from serial number TZ3406-205 to TZ3411-358)

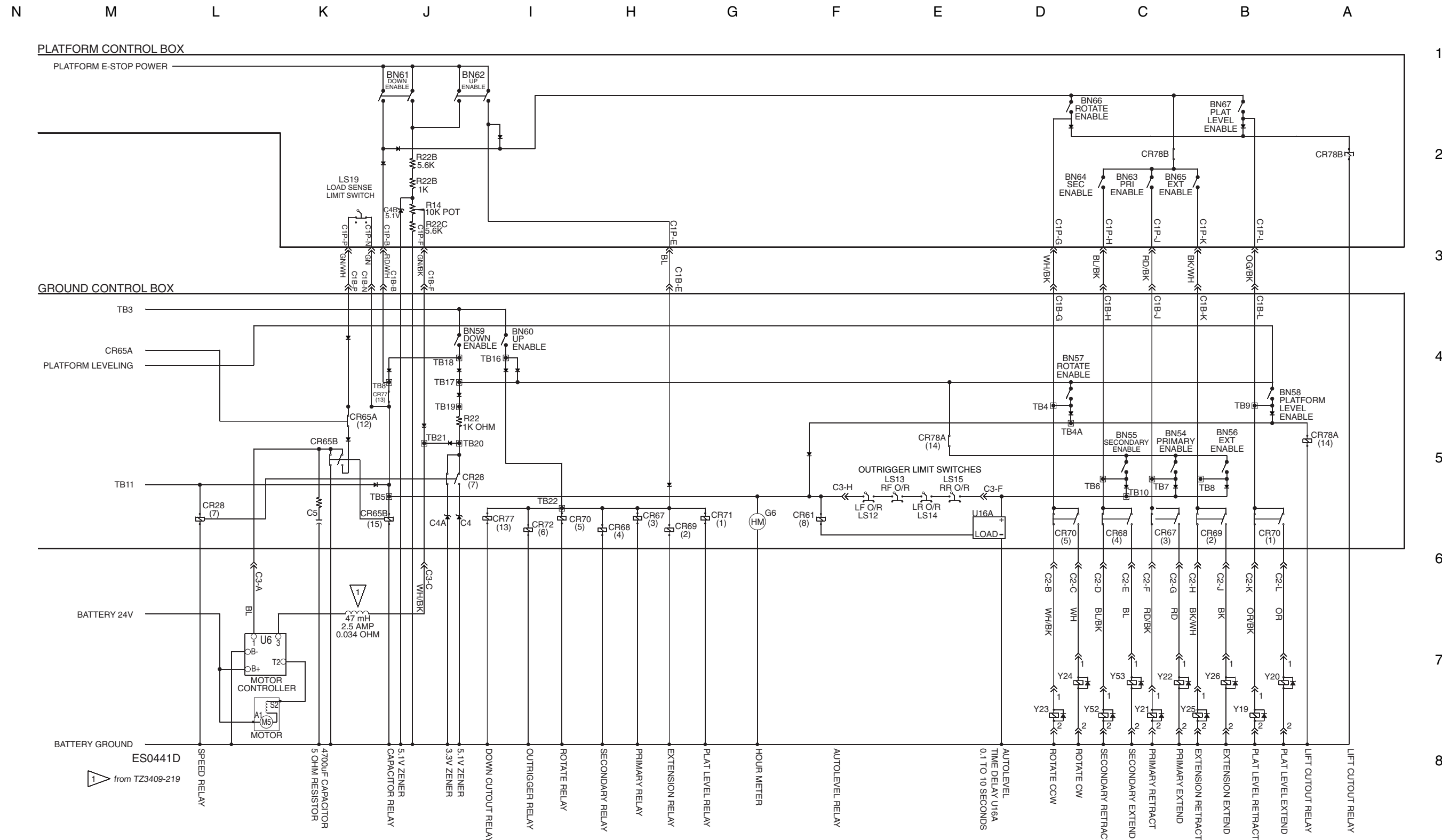

Electrical Schematic - AS/CE
(from serial number TZ3406-205 to TZ3411-358)

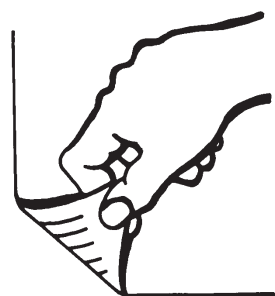

Electrical Schematic - AS/CE
(from serial number TZ3411-359 to TZ3413-344)

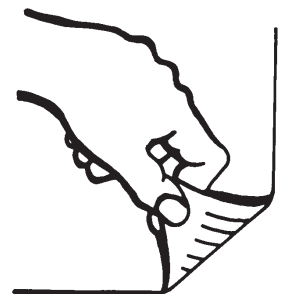
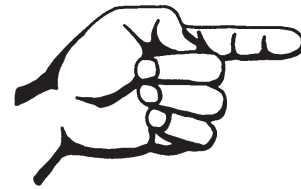

Electrical Schematic - AS/CE (from serial number TZ3411-359 to TZ3413-344)

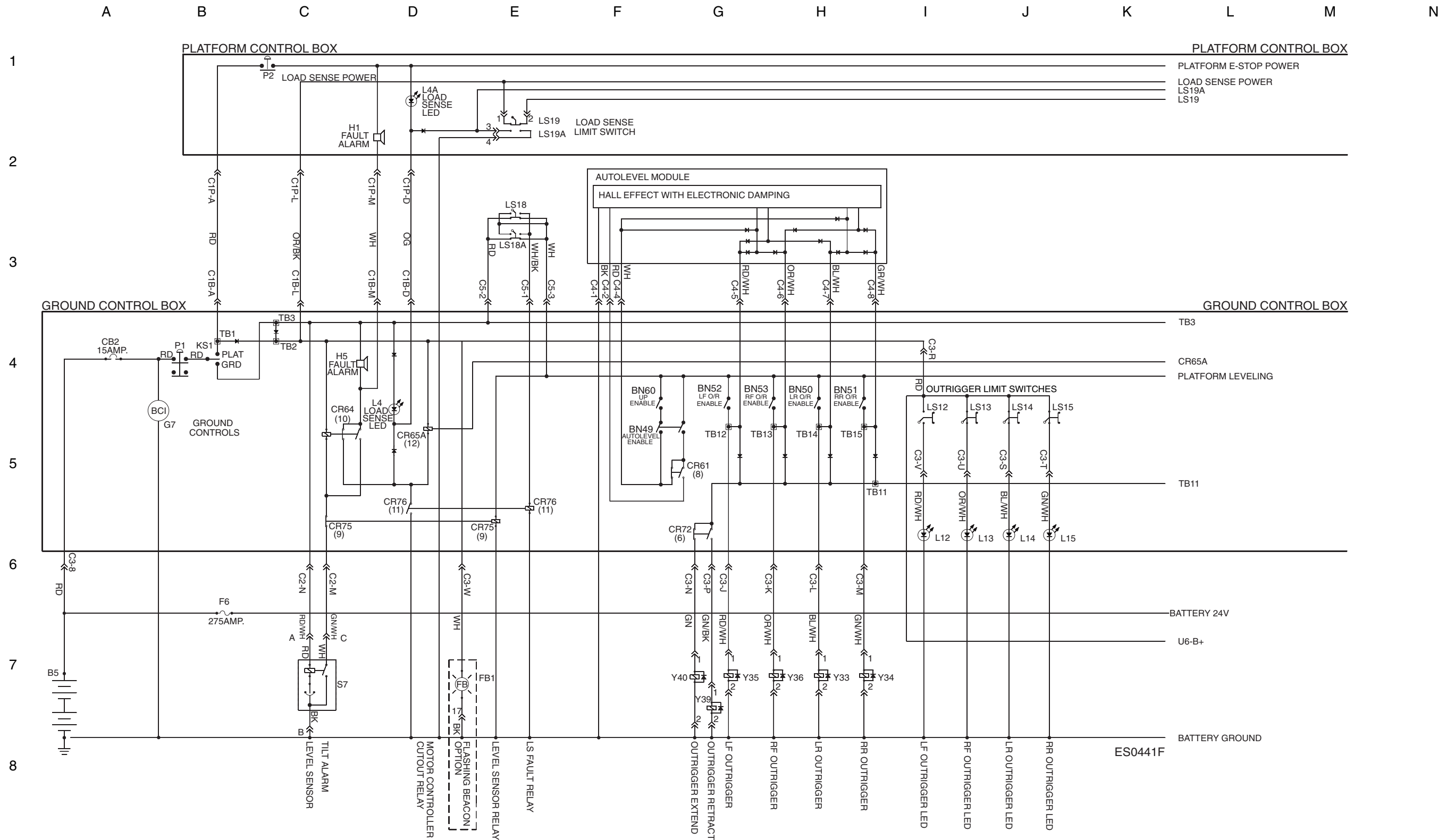

Electrical Schematic - AS/CE (from serial number TZ3411-359 to TZ3413-344)

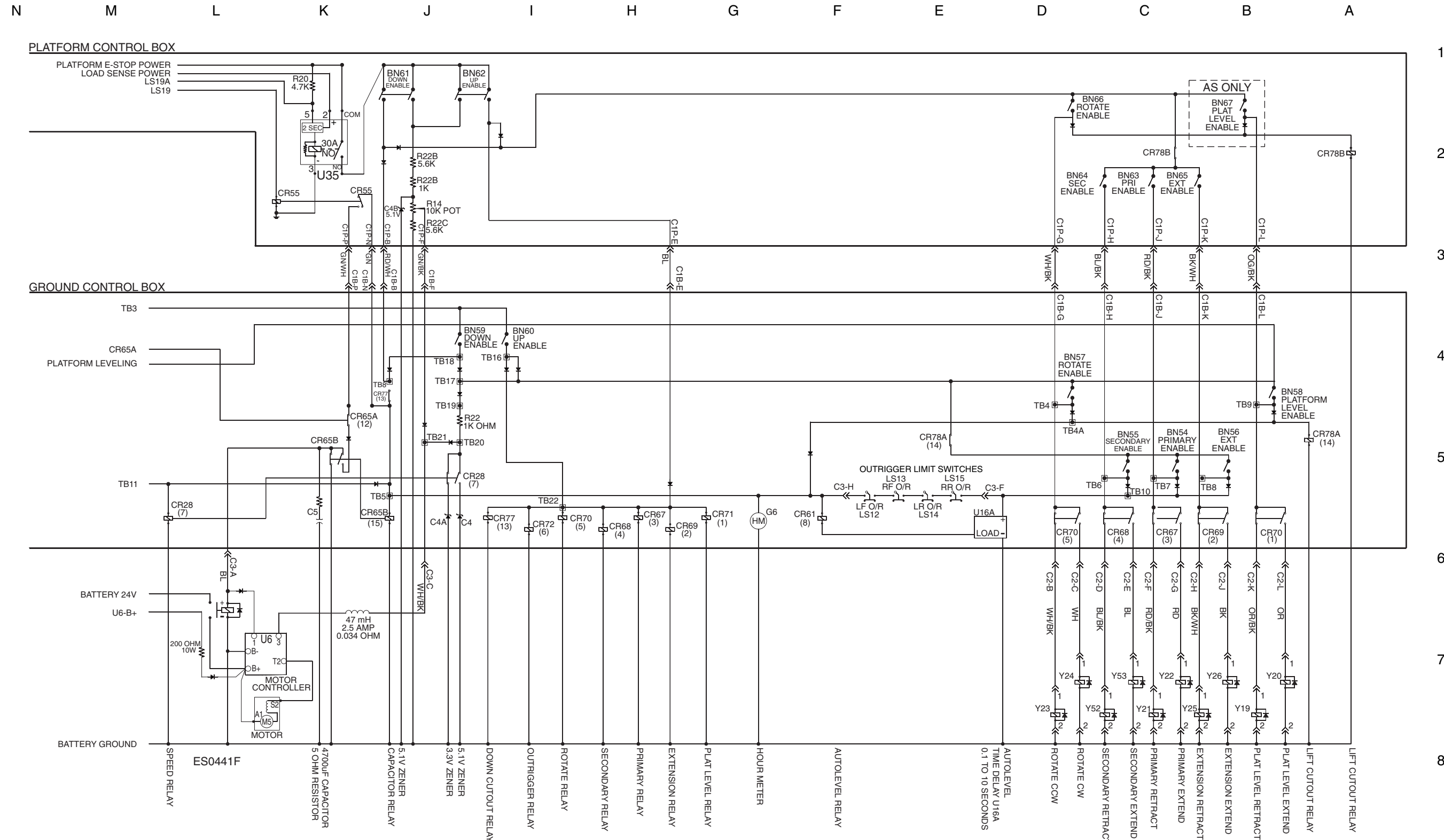

Electrical Schematic - AS/CE
(from serial number TZ3411-359 to TZ3413-344)

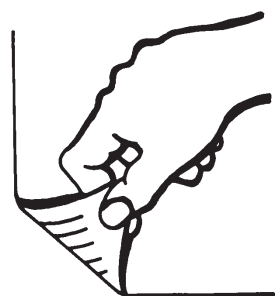

**Electrical Schematic - AS/CE
(from serial number TZ3413-345)**

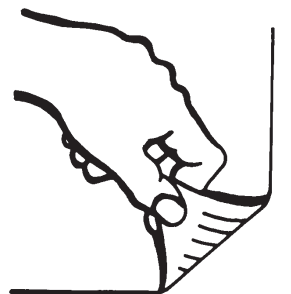
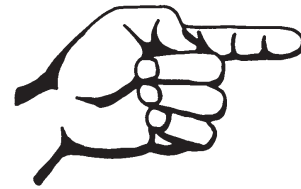

Electrical Schematic - AS/CE (from serial number TZ3413-345)

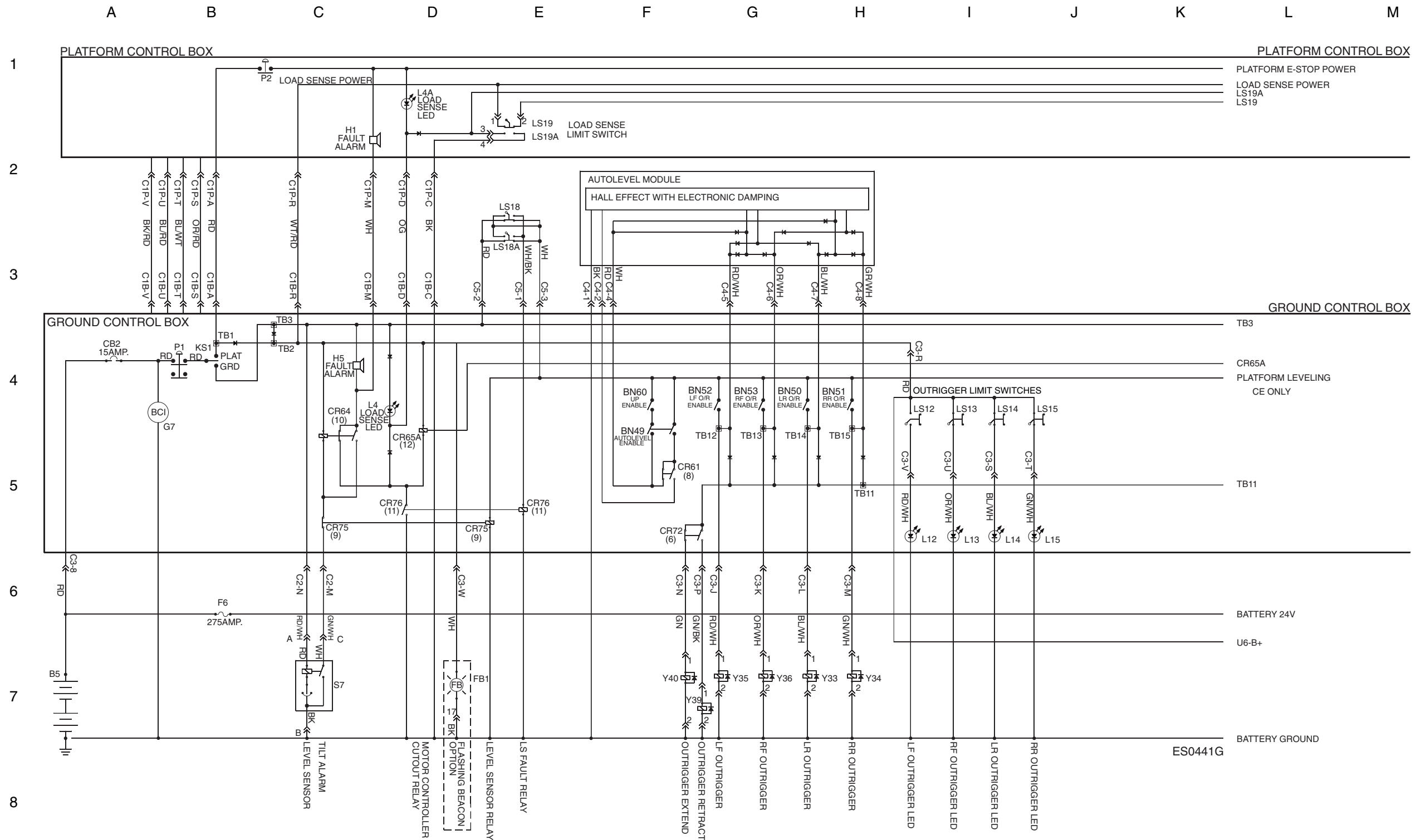

Electrical Schematic - AS/CE (from serial number TZ3413-345)

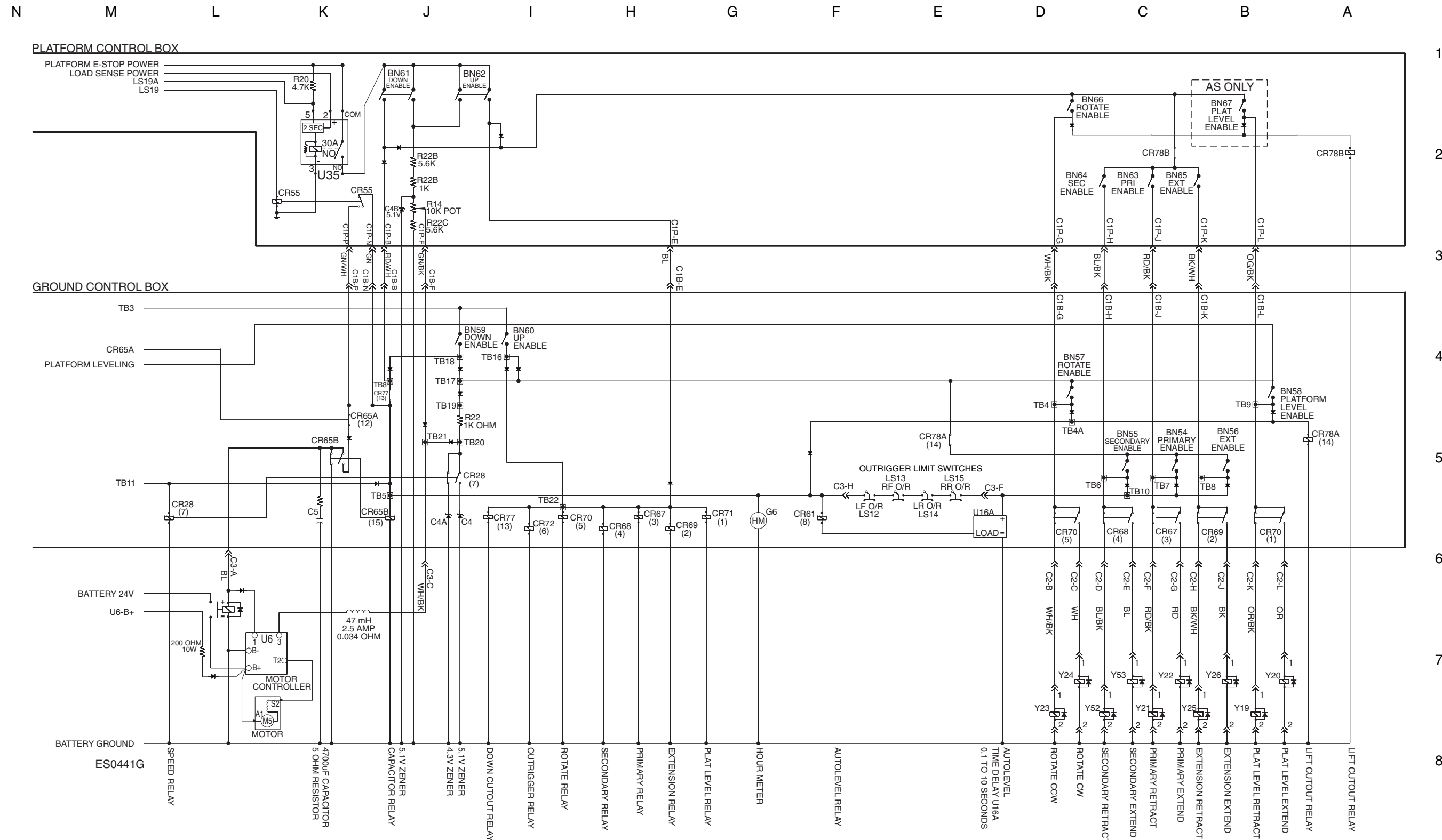

Electrical Schematic - AS/CE
(from serial number TZ3413-345)

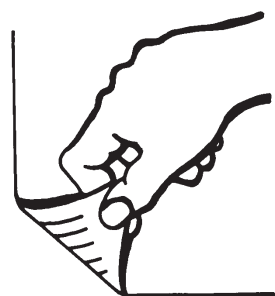

Hydraulic Schematic
(to serial number TZ3403-248)

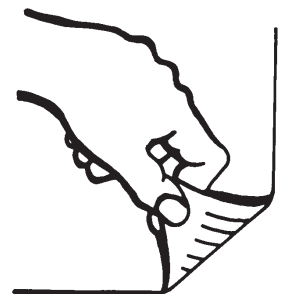
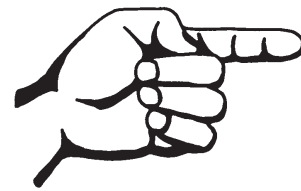

Hydraulic Schematic (to serial number TZ3403-248)

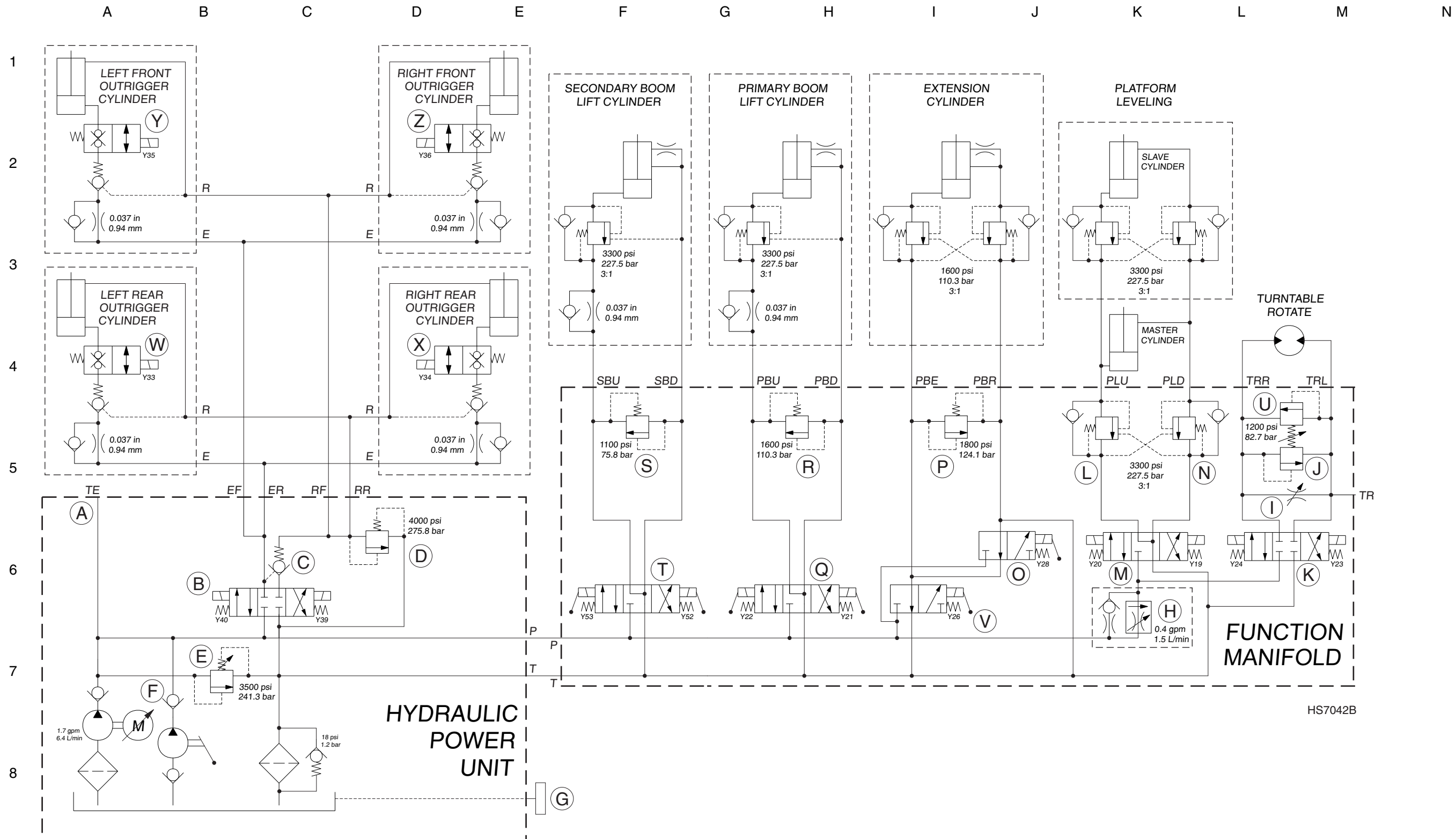

HS7042B

Hydraulic Schematic (from serial number TZ3403-249 to TZ3405-171)

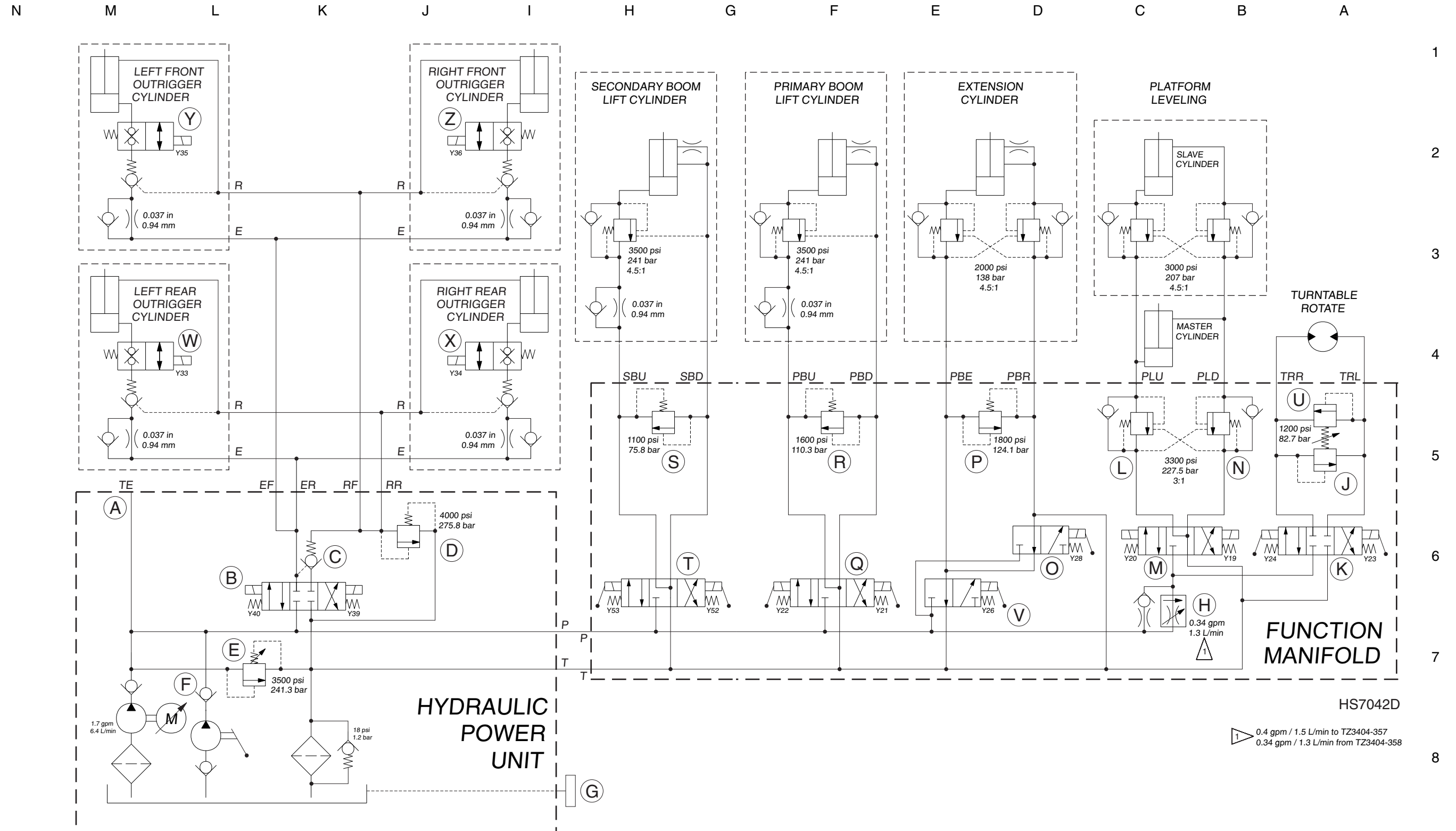

0.4 gpm / 1.5 L/min to TZ3404-357
0.34 gpm / 1.3 L/min from TZ3404-358

Hydraulic Schematic
(from serial number TZ3403-249 to TZ3405-171)

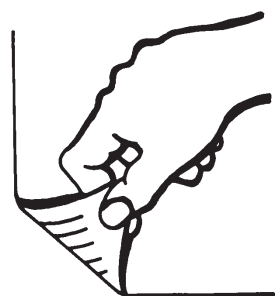

Hydraulic Schematic
(from serial number TZ3405-172 to TZ3412-298)

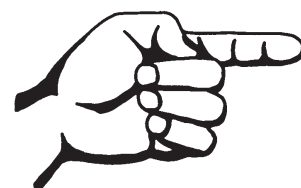

Hydraulic Schematic (from serial number TZ3405-172 to TZ3412-298)

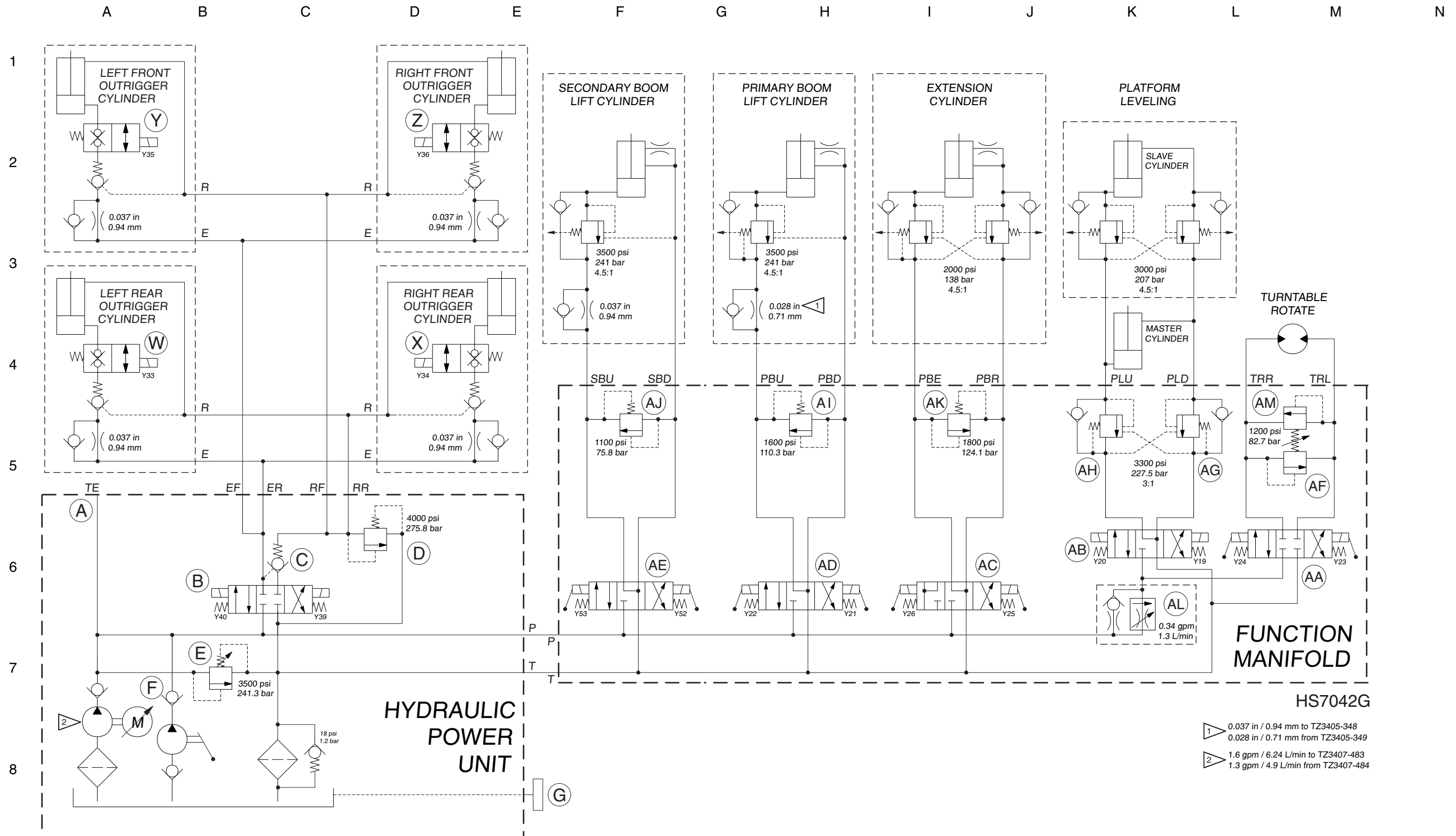

- 1 0.037 in / 0.94 mm to TZ3405-348
0.028 in / 0.71 mm from TZ3405-349
- 2 1.6 gpm / 6.24 L/min to TZ3407-483
1.3 gpm / 4.9 L/min from TZ3407-484

Hydraulic Schematic (from serial number TZ3412-299)

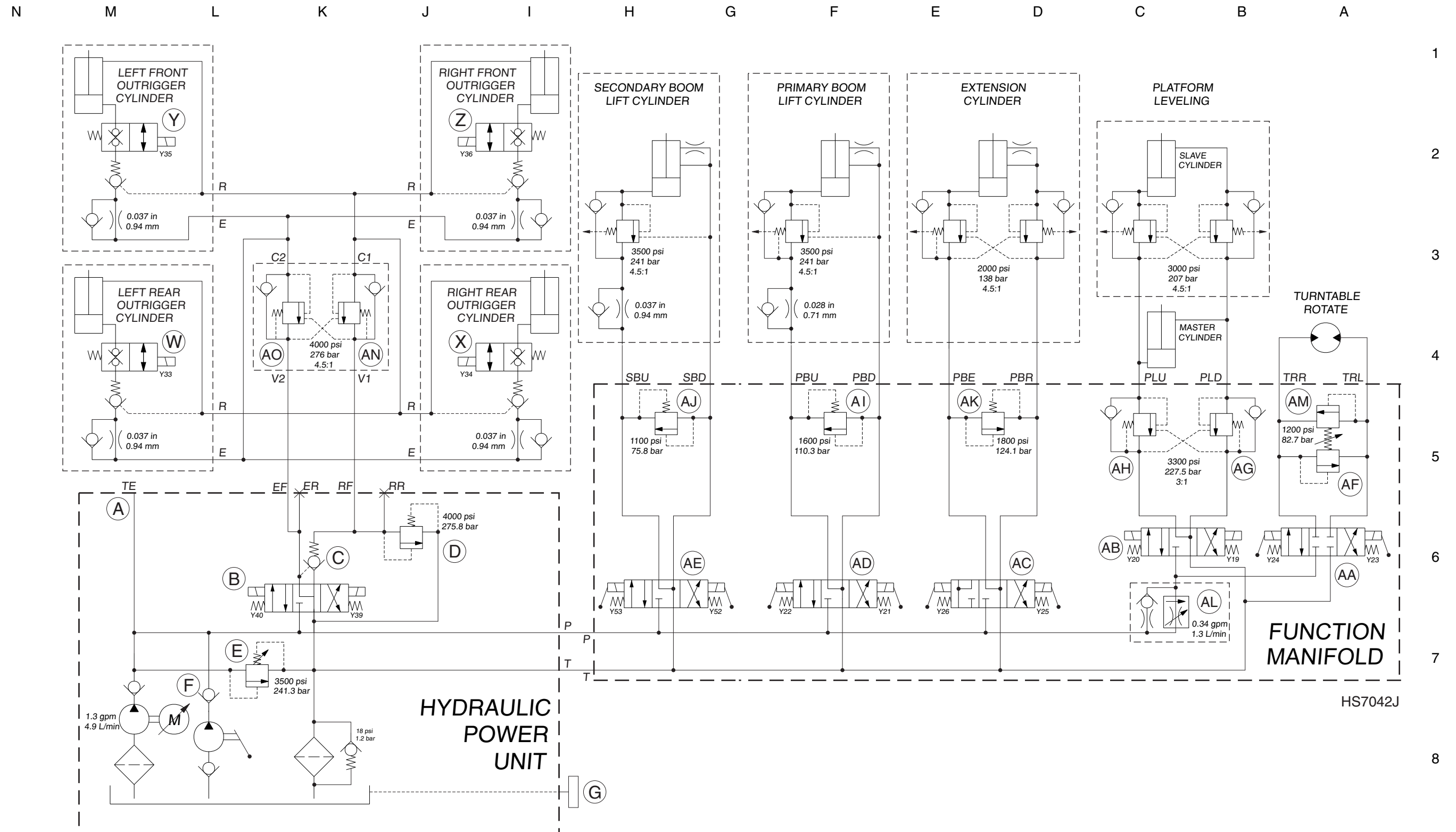

Hydraulic Schematic
(from serial number TZ3412-299)

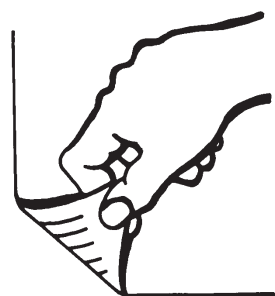

California Proposition 65



Operating, servicing and maintaining this equipment can expose you to chemicals including engine exhaust, carbon monoxide, phthalates, and lead, which are known to the State of California to cause cancer and birth defects or other reproductive harm. These chemicals can be emitted from or contained in other various parts and systems, fluids and some component wear by-products. To minimize exposure, avoid breathing exhaust, do not idle the engine except as necessary, service your equipment and vehicle in a well-ventilated area and wear gloves or wash your hands frequently when servicing your equipment or vehicle and after operation. For more information go to www.P65Warnings.ca.gov/passenger-vehicle.