



Service Manual

Serial Number Range

TZ[™]-50

from TZ5004-1
to TZ5012-253

Part No. 84577

Rev B1

September 2014

INTRODUCTION

Important

Read, understand and obey the safety rules and operating instructions in the appropriate operator's manual on your machine before attempting any maintenance or repair procedure.

This manual provides detailed scheduled maintenance information for the machine owner and user. It also provides troubleshooting fault codes and repair procedures for qualified service professionals.

Basic mechanical, hydraulic and electrical skills are required to perform most procedures. However, several procedures require specialized skills, tools, lifting equipment and a suitable workshop. In these instances, we strongly recommend that maintenance and repair be performed at an authorized Genie dealer service center.

Compliance

Machine Classification

Group B/Type 3 as defined by ISO 16368

Machine Design Life

Unrestricted with proper operation, inspection and scheduled maintenance.

Technical Publications

Genie has endeavored to deliver the highest degree of accuracy possible. However, continuous improvement of our products is a Genie policy. Therefore, product specifications are subject to change without notice.

Readers are encouraged to notify Genie of errors and send in suggestions for improvement. All communications will be carefully considered for future printings of this and all other manuals.

Contact Us:

<http://www.genielift.com>
e-mail: awp.techpub@terex.com

Copyright © 2004 Terex Corporation

84577 Rev B May 2013
First Edition, Second Printing

"Genie" and "TZ" are registered trademarks of Terex South Dakota, Inc. in the USA and many other countries.

 Printed on recycled paper

Printed in U.S.A.

Revision History

Revision	Date	Section	Procedure / Schematic Page / Description
A	11/2004		New release
B	5/2013	Introduction	Revision History Added
		2 - Spec.	Hydraulic Specifications SAE and Metric Fastener Torque Chart
		3 - Maint.	Added Specific maintenance to all axle procedures Revised procedures.
		4 - Repair	Revised procedures.
		5 - Schem.	Revised all schematics and grouped by Markets.
B1	9/2014	5 - Schem.	5-138, 5-139
REFERENCE EXAMPLES:			
<p>Honda Engine_Section 2_Specifications. A-6,B-3,C-7_Section 3_Maintenance Procedure. 3-2, 6-4, 9-1_Section 4_Repair Procedure. 5-35, 5-56, 5-104_Section 5_Schematic Page #.</p>			<p style="text-align: center;"><u>Electronic Version</u></p> <p>Click on any procedure or page number highlighted in blue to view the update.</p>

REVISION HISTORY, CONTINUED

Revision	Date	Section	Procedure / Schematic Page / Description
REFERENCE EXAMPLES:			
<p>Honda Engine_Section 2_Specifications. A-6,B-3,C-7_Section 3_Maintenance Procedure. 3-2, 6-4, 9-1_Section 4_Repair Procedure. 5-35, 5-56, 5-104_Section 5_Schematic Page #.</p>			<p style="text-align: center;"><u>Electronic Version</u></p> <p>Click on any procedure or page number highlighted in blue to view the update.</p>

Serial Number Legend





Model: TZ-50
Serial number: TZ5011-299
Model year: 2011 **Manufacture date:** 03/14/11
Electrical schematic number: Position 3
Machine unladen weight: 99.999 lbs / 99.999 kg
Rated work load (including occupants):
 Position 4
Maximum number of platform occupants: Pos 5
Maximum allowable side force: Position 6
Maximum allowable inclination of the chassis:
 Position 7
Maximum wind speed: Position 8
Maximum platform height: Position 9
Maximum platform reach: Position 10
Power supply voltage: Position 12
Gradeability: Position 11
Control system voltage: Position 13
Nominal battery/design voltage power: Position 14
Nominal Power: Position 40
Maximum hydraulic pressure: Position 27
Country of manufacture:
Manufacturer:
Terex USA, LLC.
590 Huey Road
Rock Hill, SC 29732
USA
European Representative:
 Genie UK LTD
 The Maltings
 Wharf Road, Grantham, Lin
 NG31 6BH United Kingdom

This machine complies with:
 Compliance STD #1
 Compliance STD #2
 Compliance STD #3

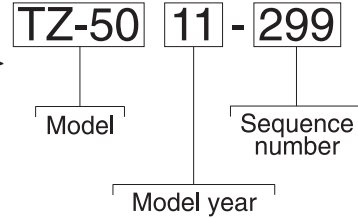

PN - 77055

DATE:
GVWR / PNBV: 99.999 lbs/ 99.99 kg
GAWR / PNBE: 99.999 lbs/ 99.99 kg
TIRES / PNEU: Position 25
RIMS / JANTE: Position 24
COLD TIRE INFLATION/ Position 26
PRESS.DE GONFL. A FROID 'SINGLE'
 THIS VEHICLE CONFORMS TO ALL APPLICABLE U.S. FEDERAL MOTOR VEHICLE SAFETY STANDARDS IN EFFECT ON THE DATE OF MANUFACTURE SHOWN ABOVE.
 THIS VEHICLE CONFORMS TO ALL APPLICABLE STANDARDS PRESCRIBED UNDER THE CANADIAN MOTOR VEHICLE SAFETY REGULATIONS IN EFFECT ON THE DATE OF MANUFACTURE/ CE VEHICULE EST CONFORME A TOUTES LES NORMES QUI LUI SONT APPLICABLES EN VERTU DU REGLAMENT SUR LA SECURITE DES VEHICULES AUTOMOBILES DU CANADA EN VIGUER A LA DATE DE SA FABRICATION
V.I.N./N.I.V.:
TYPE OF VEHICLE/TYPE DE VEHICULE:TRAILER/REMORQUE
MODEL: TZ-50
SERIAL NUMBER: TZ5011-299
MODEL YEAR: 2011
ELECTRICAL SCHEMATIC: ES0440
NOMINAL POWER: Position 40



PN - 77172

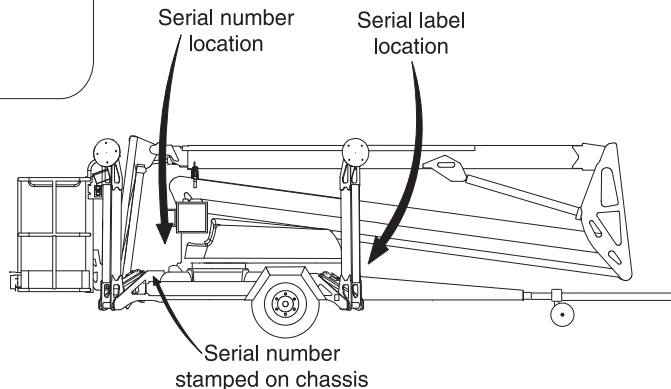

Safety Rules



Danger

Failure to obey the instructions and safety rules in this manual and the appropriate Operator's Manual on your machine will result in death or serious injury.

Many of the hazards identified in the operator's manual are also safety hazards when maintenance and repair procedures are performed.

Do Not Perform Maintenance Unless:

- You are trained and qualified to perform maintenance on this machine.
- You read, understand and obey:
 - manufacturer's instructions and safety rules
 - employer's safety rules and worksite regulations
 - applicable governmental regulations
- You have the appropriate tools, lifting equipment and a suitable workshop.

Personal Safety

Any person working on or around a machine must be aware of all known safety hazards. Personal safety and the continued safe operation of the machine should be your top priority.



Read each procedure thoroughly. This manual and the decals on the machine, use signal words to identify the following:



Safety alert symbol—used to alert personnel to potential personal injury hazards. Obey all safety messages that follow this symbol to avoid possible injury or death.



Indicates an imminently hazardous situation which, if not avoided, will result in death or serious injury.



Indicates a potentially hazardous situation which, if not avoided, could result in death or serious injury.



Indicates a potentially hazardous situation which, if not avoided, may cause minor or moderate injury.



Indicates a potentially hazardous situation which, if not avoided, may result in property damage.



Be sure to wear protective eye wear and other protective clothing if the situation warrants it.



Be aware of potential crushing hazards such as moving parts, free swinging or unsecured components when lifting or placing loads. Always wear approved steel-toed shoes.

SAFETY RULES

Workplace Safety



Be sure to keep sparks, flames and lighted tobacco away from flammable and combustible materials like battery gases and engine fuels. Always have an approved fire extinguisher within easy reach.



Be sure that all tools and working areas are properly maintained and ready for use. Keep work surfaces clean and free of debris that could get into machine components and cause damage.



Be sure any forklift, overhead crane or other lifting or supporting device is fully capable of supporting and stabilizing the weight to be lifted. Use only chains or straps that are in good condition and of ample capacity.



Be sure that fasteners intended for one time use (i.e., cotter pins and self-locking nuts) are not reused. These components may fail if they are used a second time.



Be sure to properly dispose of old oil or other fluids. Use an approved container. Please be environmentally safe.



Be sure that your workshop or work area is properly ventilated and well lit.

Table of Contents

Introduction

Important Information	<i>ii</i>
Revision History	<i>iii</i>
Serial Number Legend	<i>v</i>

Section 1 **Safety Rules**

General Safety Rules	<i>vi</i>
----------------------------	-----------

Section 2 **Specifications**

Machine Specifications	2 - 1
Performance Specifications	2 - 2
Hydraulic Specifications	2 - 2
Manifold Component Specifications	2 - 3
Machine Torque Specifications	2 - 4
Honda GX160K1 Engine Specifications	2 - 5
Hydraulic Hose and Fitting Torque Specifications	2 - 6
SAE and Metric Fastener Torque Chart	2 - 8

Section 3 **Scheduled Maintenance Procedures**

Introduction	3 - 1
Pre-delivery Preparation Report	3 - 3
Maintenance Inspection Report	3 - 5
Checklist A Procedures	
A-1 Inspect the Manuals and Decals	3 - 6
A-2 Perform Pre-operation Inspection	3 - 6
A-3 Perform Function Tests	3 - 7
A-4 Perform Engine Maintenance (if equipped)	3 - 7

Section 3 **Scheduled Maintenance Procedures, continued**

A-5 Torque the Lug Bolts - Electrical and Hydraulic Axles 3 - 8

A-6 Torque the Lug Bolts - Mechanical Axle 3 - 8

A-7 Perform Hitch Maintenance - Hydraulic Axle 3 - 9

A-8 Perform Engine Maintenance (if equipped) 3 - 9

A-9 Perform 30 Day Service 3 - 10

A-10 Perform Engine Maintenance (if equipped) 3 - 10

A-11 Grease the Turntable Rotation Bearing and Rotate Gear 3 - 11

A-12 Perform Engine Maintenance (if equipped) 3 - 11

Checklist B Procedures

B-1 Inspect the Batteries 3 - 12

B-2 Inspect the Electrical Wiring 3 - 13

B-3 Test the Electrical Contactor 3 - 14

B-4 Test the Emergency Stop 3 - 14

B-5 Test the Key Switch 3 - 15

B-6 Test the Manual Override 3 - 15

B-7 Perform Hydraulic Oil Analysis 3 - 17

B-8 Perform Axle Maintenance - Electrical and Hydraulic Axles 3 - 18

B-9 Service the Tongue Jack 3 - 18

B-10 Inspect the Parking Brake 3 - 19

B-11 Check the Wheel Bearings - Mechanical Axle 3 - 24

B-12 Service the Hitch - Mechanical Axle 3 - 25

B-13 Perform Axle Maintenance - Mechanical Axle 3 - 26

B-14 Perform Engine Maintenance (if equipped) 3 - 26

 TABLE OF CONTENTS

Section 3	Scheduled Maintenance Procedures, continued	
	Checklist C Procedures	
C-1	Grease the Platform Overload Mechanism (if equipped)	3 - 27
C-2	Test the Platform Overload System (if equipped)	3 - 27
C-3	Perform Axle Maintenance - Electrical and Hydraulic Axles	3 - 28
C-4	Replace the Hydraulic Tank Breather Cap - Models with Optional Hydraulic Oil	3 - 29
C-5	Grease the Axle Wheel Bearings - Mechanical Axle	3 - 29
C-6	Adjust the Brakes - Mechanical Axle	3 - 30
	Checklist D Procedures	
D-1	Perform Axle Maintenance - Electrical and Hydraulic Axles	3 - 32
D-2	Check the Boom Wear Pads	3 - 32
D-3	Replace the Hydraulic Tank Return Filter	3 - 33
D-4	Check the Turntable Rotation Bearing Bolts	3 - 34
D-5	Inspect for Turntable Bearing Wear	3 - 35
	Checklist E Procedures	
E-1	Test or Replace the Hydraulic Oil	3 - 36
E-2	Perform Engine Maintenance (if equipped)	3 - 37

TABLE OF CONTENTS

Section 4	Repair	
	Introduction	4 - 1
	Platform Components	
	1-1 Platform	4 - 2
	1-2 Platform Rotator	4 - 2
	Jib Boom Components	
	2-1 Jib Boom	4 - 4
	2-2 Jib Boom Lift Cylinder	4 - 6
	Primary Boom Components	
	3-1 Cable Track	4 - 9
	3-2 Primary Boom	4 - 11
	3-3 Primary Boom Lift Cylinder	4 - 14
	3-4 Platform Leveling Cylinders	4 - 15
	Secondary Boom Components	
	4-1 Secondary Boom	4 - 18
	4-2 Secondary Boom Lift Cylinder	4 - 21
	Engine	
	5-1 Fuse Replacement	4 - 23
	Ground Controls	
	6-1 Level Sensor	4 - 24
	Hydraulic Pump	
	7-1 Function Pump	4 - 28
	Manifolds	
	8-1 Function Manifold Components	4 - 30
	8-2 Jib Manifold Components	4 - 32
	8-3 Drive Manifold Components (if equipped)	4 - 34
	8-4 Valve Adjustments - Function Manifold	4 - 36
	8-5 Valve Coils	4 - 38

 TABLE OF CONTENTS

Section 4	Repair, continued	
	Hydraulic Tank	
9-1	Hydraulic Tank	4 - 40
	Axle Components	
10-1	Axle	4 - 41
	Trailer Components	
11-1	Hydraulic and Mechanical Brakes	4 - 42
11-2	Parking Brake	4 - 42
	Outriggers	
12-1	Outrigger Components	4 - 43
12-2	Outrigger Cylinder	4 - 44
	Platform Overload Components	
13-1	Platform Overload System	4 - 45
	Drive Components	
14-1	Drive Motor	4 - 47
14-2	Drive Control Box	4 - 48

TABLE OF CONTENTS

Section 5	Schematics	
	Introduction	5 - 1
	Electrical Abbreviations Legend	5 - 2
	Abbreviation Legend - Wire Colors	5 - 4
	Limit Switch Legend	5 - 5
	Electrical Symbols Legend	5 - 6
	Abbreviation Legend - Hydraulic Schematics	5 - 7
	Hydraulic Symbols Legend	5 - 8
	Honda GX160 Engine Wiring Diagram	5 - 9
	Trailer Lighting Wiring Diagram - ANSI / CSA	5 - 10
	Trailer Lighting Wiring Diagram - Mechanical Axle, CE (to SN TZ5012-215)	5 - 11
	Trailer Lighting Wiring Diagram - Mechanical Axle, CE (from SN TZ5012-216)	5 - 12
	Trailer Lighting Wiring Diagram - Electric Axle, AUS (to SN TZ5012-252)	5 - 13
	Trailer Lighting Wiring Diagram - Electric Axle, AUS (from SN TZ5012-253)	5 - 14
	Trailer Lighting Wiring Diagram - Hydraulic Axle, AUS (from SN TZ5012-216)	5 - 15

 TABLE OF CONTENTS

Section 5	Schematics, continued	
	<u>Control Box Wiring Diagrams - ANSI/CSA</u>	
	Ground Control Box Wiring Diagram - ANSI/CSA (to serial number TZ5004-181)	5 - 16
	Ground Control Box Wiring Diagram - ANSI/CSA (from serial number TZ5004-182 to TZ5004-324)	5 - 18
	Ground Control Box Wiring Diagram - ANSI/CSA (from serial number TZ5004-325 to TZ5005-284)	5 - 20
	Ground Control Box Wiring Diagram - ANSI/CSA (from serial number TZ5005-285 to TZ5010-144)	5 - 22
	Ground Control Box Wiring Diagram - ANSI/CSA (from serial number TZ5010-145 to TZ5011-131)	5 - 24
	Ground Control Box Wiring Diagram - ANSI/CSA (from serial number TZ5011-132)	5 - 26
	Platform Control Box Wiring Diagram - ANSI/CSA (to serial number TZ5004-181)	5 - 28
	Platform Control Box Wiring Diagram - ANSI/CSA (from serial number TZ5004-182 to TZ5005-284)	5 - 29
	Platform Control Box Wiring Diagram - ANSI/CSA (from serial number TZ5005-285 to TZ5010-144)	5 - 30
	Platform Control Box Wiring Diagram - ANSI/CSA (from serial number TZ5010-145 to TZ5011-131)	5 - 31
	Platform Control Box Wiring Diagram - ANSI/CSA (from serial number TZ5011-132)	5 - 32
	Drive Control Box Wiring Diagram - ANSI/CSA (to serial number TZ5004-284)	5 - 33

Section 5 Schematics, continued

Control Box Wiring Diagrams - AS/CE

Ground Control Box Wiring Diagram - AS/CE
 (to serial number TZ5004-181) 5 - 34

Ground Control Box Wiring Diagram - AS/CE
 (from serial number TZ5004-182 to TZ5004-324) 5 - 36

Ground Control Box Wiring Diagram - AS/CE
 (from serial number TZ5004-325 to TZ5005-284) 5 - 38

Ground Control Box Wiring Diagram - AS/CE
 (from serial number TZ5005-285 to TZ5010-144) 5 - 40

Ground Control Box Wiring Diagram - AS/CE
 (from serial number TZ5010-145 to TZ5011-131) 5 - 42

Ground Control Box Wiring Diagram - AS/CE
 (from serial number TZ5011-132) 5 - 44

Platform Control Box Wiring Diagram - AS/CE
 (to serial number TZ5004-181) 5 - 46

Platform Control Box Wiring Diagram - AS/CE
 (from serial number TZ5004-182 to TZ5005-284) 5 - 47

Platform Control Box Wiring Diagram - AS/CE
 (from serial number TZ5005-285 to TZ5010-144) 5 - 48

Platform Control Box Wiring Diagram - AS/CE
 (from serial number TZ5010-145 to TZ5011-131) 5 - 49

Platform Control Box Wiring Diagram - AS/CE
 (from serial number TZ5011-132) 5 - 50

Drive Control Box Wiring Diagram - AS/CE
 (to serial number TZ5004-284) 5 - 51

 TABLE OF CONTENTS

Section 5	Schematics, continued	
	<u>Electrical Schematics - ANSI/CSA</u>	
	Electrical Schematic - ANSI/CSA (to serial number TZ5004-181)	5 - 54
	Electrical Schematic - ANSI/CSA (from serial number TZ5004-182 to TZ5005-210)	5 - 60
	Electrical Schematic - ANSI/CSA (from serial number TZ5005-211 to TZ5005-284)	5 - 66
	Electrical Schematic - ANSI/CSA (from serial number TZ5005-285 to TZ5010-144)	5 - 72
	Electrical Schematic - ANSI/CSA (from serial number TZ5010-145 to TZ5011-131)	5 - 78
	Electrical Schematic - ANSI/CSA (from serial number TZ5011-132 to TZ5011-310)	5 - 84
	Electrical Schematic - ANSI/CSA (from serial number TZ5011-311)	5 - 90
	<u>Electrical Schematics - AS/CE</u>	
	Electrical Schematic - AS/CE (to serial number TZ5004-181)	5 - 96
	Electrical Schematic - AS/CE (from serial number TZ5004-182 to TZ5005-210)	5 - 102
	Electrical Schematic - AS/CE (from serial number TZ5005-211 to TZ5005-284)	5 - 108
	Electrical Schematic - AS/CE (from serial number TZ5005-285 to TZ5010-144)	5 - 114
	Electrical Schematic - AS/CE (from serial number TZ5010-145 to TZ5011-131)	5 - 120
	Electrical Schematic - AS/CE (from serial number TZ5011-132 to TZ5011-310)	5 - 126
	Electrical Schematic - AS/CE (from serial number TZ5011-311)	5 - 132
	<u>Hydraulic Schematics</u>	
	Hydraulic Schematic (to serial number TZ5006-510)	5 - 138
	Hydraulic Schematic (from serial number TZ5006-511)	5 - 139

Specifications

Machine Specifications

Batteries, models without drive option

Type	6V DC
Group	T-105
Quantity	4
Battery capacity	225AH
Reserve capacity @ 25A rate	447 minutes

Batteries, models with drive option

Type	6V DC
Group	T-145
Quantity	4
Battery capacity	244AH
Reserve capacity @ 25A rate	530 minutes

Fluid capacities

Hydraulic tank	4.75 gallons 18 liters
Hydraulic system (including tank)	8 gallons 30 liters

Tires and wheels - Electric and Hydraulic Axles

Axle

Tire size	ST225/75R15
Load range	D
Lug nut torque, dry	80 ft-lbs 108 Nm
Tire pressure, maximum (cold)	65 psi 4.48 bar

Tires and wheels - Mechanical Axle

Axle

Tire size	215/70R14 104/102N
Load range	C
Lug bolt torque, dry	192 ft-lbs 260 Nm
Tire pressure, maximum (cold)	66 psi 4.55 bar

Tongue jack - all models

To TZ5005-204	
Tire size	12 x 3.5 x 0.75
From TZ5005-205	
Tire size	10 x 3 x 0.75

For operational specifications, refer to the Operator's Manual.

Continuous improvement of our products is a Genie policy. Product specifications are subject to change without notice.

SPECIFICATIONS

Performance Specifications

Boom function speeds, maximum from platform controls (no weight in platform)	
Primary boom up	18 to 26 seconds
Primary boom down	17 to 26 seconds
Primary boom extend	13 to 20 seconds
Primary boom retract	16 to 24 seconds
Secondary boom up	17 to 25 seconds
Secondary boom up (with drive option)	20 to 30 seconds
Secondary boom down	16 to 24 seconds
Jib boom up	16 to 22 seconds
Jib boom down	16 to 22 seconds
Platform rotate (if equipped)	8 to 12 seconds
Turntable rotate - 359°	110 to 140 seconds
Airborne noise emissions Maximum sound level at normal operation workstations (A-weighted)	80 dB

For operational specifications, refer to the Operators Manual.

Hydraulic Specifications**Hydraulic Oil Specifications**

Hydraulic oil type	Chevron Rando HD equivalent
Viscosity grade	Multi-viscosity
Viscosity index	200
Cleanliness level, minimum	15/13
Water content, maximum	200 ppm

Chevron Rando HD oil is fully compatible and mixable with Shell Donax TG (Dexron III) oils.

Genie specifications require hydraulic oils which are designed to give maximum protection to hydraulic systems, have the ability to perform over a wide temperature range, and the viscosity index should exceed 140. They should provide excellent antiwear, oxidation, corrosion inhibition, seal conditioning, and foam and aeration suppression properties.

Optional fluids

Biodegradable	Petro Canada Environ MV 46 Statoil Hydra Way Bio Pa 32 BP Biohyd SE-S
Fire resistant	UCON Hydrolube HP-5046 Quintolubric 822
Mineral based	Shell Tellus S2 V 32 Shell Tellus S2 V 46 Chevron Aviation A Arnica 32

Note: Continued use of Chevron Aviation A hydraulic fluid when ambient temperatures are consistently above 32°F / 0°C may result in component damage.

Continuous improvement of our products is a Genie policy. Product specifications are subject to change without notice.

SPECIFICATIONS

Note: Use Chevron Aviation A hydraulic fluid when ambient temperatures are consistently below 0°F / -17°C.

Note: Use Shell Tellus S2 V 46 hydraulic oil when oil temperatures consistently exceed 205°F / 96°C.

Note: Genie specifications require additional equipment and special installation instructions for the approved optional fluids. Consult the Genie Service Department before use.

Function pump (models without drive option)

Type:	single section gear pump
Displacement per revolution	0.244 cu in 4 cc
Flow rate	2.8 gpm 10.6 L/min
Hydraulic tank return line filter	10 micron

Function pump (models with drive option)

Type:	2 section pressure balanced gear pump
Displacement per revolution	0.488 cu in 8 cc
Flow rate	5.6 gpm 21.2 L/min
Hydraulic tank return line filter	10 micron

Function manifold

System relief valve pressure	3000 psi 207 bar
Turntable rotate relief valve pressure	600 psi 41 bar
Primary boom down relief valve pressure	1600 psi 110 bar

Manifold Component Specifications

Plug torque

SAE No. 2	36 in-lbs / 4 Nm
SAE No. 4	10 ft-lbs / 13 Nm
SAE No. 6	14 ft-lbs / 19 Nm
SAE No. 8	38 ft-lbs / 51 Nm
SAE No. 10	41 ft-lbs / 55 Nm
SAE No. 12	56 ft-lbs / 76 Nm

Continuous improvement of our products is a Genie policy. Product specifications are subject to change without notice.

SPECIFICATIONS

Machine Torque Specifications**Platform rotator**

$\frac{3}{4}$ -10 center bolt, lubricated	200 ft-lbs 271 Nm
---	----------------------

$\frac{3}{8}$ -16 bolts, lubricated	32 ft-lbs 43 Nm
-------------------------------------	--------------------

Turntable rotate motor

$\frac{1}{2}$ -13 bolts, dry	60 ft-lbs 81 Nm
------------------------------	--------------------

Turntable rotate motor pinion

$\frac{5}{8}$ -18 bolt, dry	180 ft-lbs 244 Nm
-----------------------------	----------------------

Turntable rotate bearing

all bolts, lubricated	195 ft-lbs 264 Nm
-----------------------	----------------------

Hitch mounting bolts

$\frac{5}{8}$ -11 bolts, dry	170 ft-lbs 230 Nm
------------------------------	----------------------

Continuous improvement of our products is a Genie policy. Product specifications are subject to change without notice.

SPECIFICATIONS

Honda GX160K1 Engine

Displacement	9.9 cu in 163 cm ²
Number of cylinders	1
Bore & stroke	2.7 x 1.8 inches 68 x 45 mm
Horsepower	5.4 hp @ 3600 rpm 4 kW @ 3600 rpm
Engine idle - no load	3400 rpm
Engine idle - under load (alternator)	3100 rpm
Compression ratio	8.5:1
Valve Clearance, cold	
Intake	0.006 in (0.15 mm)
Exhaust	0.008 in (0.20 mm)
Lubrication system	splash
Oil capacity	0.63 quarts 0.6 liters
Oil viscosity requirements	
Temperature below 30°F / 0°C	5W-30
-4°F to 100°F / -20°C to 38°C	10W-30
Temperature above 50°F / 10°C	30W
Use oils meeting API classification SJ as they offer improved wear protection. Units ship with 10W-30 SJ.	

Starter motor	12 V DC
Cooling System	Forced air
Ignition System	
Spark plug type	BPR6ES (NGK) W20EPR-U (DENSO)
Spark plug gap	0.028 to 0.031 inches 0.7 to 0.8 mm
Fuel	unleaded gasoline 86 octane minimum
Fuel tank capacity	0.95 gallons 3.6 liters

Continuous improvement of our products is a Genie policy. Product specifications are subject to change without notice.

SPECIFICATIONS

Hydraulic Hose and Fitting Torque Specifications

Your machine is equipped with Parker Seal-Lok™ ORFS or 37° JIC fittings and hose ends. Genie specifications require that fittings and hose ends be torqued to specification when they are removed and installed or when new hoses or fittings are installed.

Seal-Lok™ Fittings (hose end - ORFS)

SAE Dash size	Torque
-4	10 ft-lbs / 13.6 Nm
-6	30 ft-lbs / 40.7 Nm
-8	40 ft-lbs / 54.2 Nm
-10	60 ft-lbs / 81.3 Nm
-12	85 ft-lbs / 115 Nm
-16	110 ft-lbs / 150 Nm
-20	140 ft-lbs / 190 Nm
-24	180 ft-lbs / 245 Nm

JIC 37° Fittings (swivel nut or hose connection)

SAE Dash size	Thread Size	Flats
-4	7/16-20	2
-6	9/16-18	1 1/4
-8	3/4-16	1
-10	7/8-14	1
-12	1 1/16-12	1
-16	1 5/16-12	1
-20	1 5/8-12	1
-24	1 7/8-12	1

SAE O-ring Boss Port (tube fitting - installed into Aluminum) (all types)

SAE Dash size	Torque
-4	14 ft-lbs / 19 Nm
-6	23 ft-lbs / 31.2 Nm
-8	36 ft-lbs / 54.2 Nm
-10	62 ft-lbs / 84 Nm
-12	84 ft-lbs / 114 Nm
-16	125 ft-lbs / 169.5 Nm
-20	151 ft-lbs / 204.7 Nm
-24	184 ft-lbs / 249.5 Nm

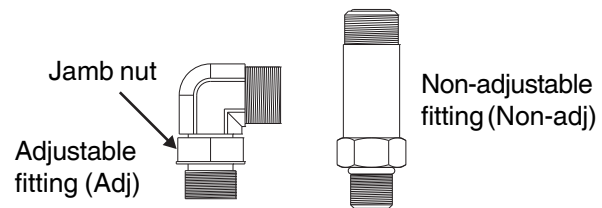

SAE O-ring Boss Port (tube fitting - installed into Steel)

SAE Dash size	Torque
-4 ORFS / 37° (Adj)	15 ft-lbs / 20.3 Nm
ORFS (Non-adj)	26 ft-lbs / 35.3 Nm
37° (Non-adj)	22 ft-lbs / 30 Nm
-6 ORFS (Adj / Non-adj)	35 ft-lbs / 47.5 Nm
37° (Adj / Non-adj)	29 ft-lbs / 39.3 Nm
-8 ORFS (Adj / Non-adj)	60 ft-lbs / 81.3 Nm
37° (Adj / Non-adj)	52 ft-lbs / 70.5 Nm
-10 ORFS (Adj / Non-adj)	100 ft-lbs / 135.6 Nm
37° (Adj / Non-adj)	85 ft-lbs / 115.3 Nm
-12 (All types)	135 ft-lbs / 183 Nm
-16 (All types)	200 ft-lbs / 271.2 Nm
-20 (All types)	250 ft-lbs / 339 Nm
-24 (All types)	305 ft-lbs / 413.5 Nm

SPECIFICATIONS

Torque Procedure

Seal-Lok™ fittings

- 1 Replace the O-ring. The O-ring must be replaced anytime the seal has been broken. The O-ring cannot be re-used if the fitting or hose end has been tightened beyond finger tight.

Note: The O-rings used in the Parker Seal Lok™ fittings and hose ends are custom-size O-rings. They are not standard SAE size O-rings. They are available in the O-ring field service kit (Genie part number 49612).

- 2 Lubricate the O-ring before installation.
- 3 Be sure that the face seal O-ring is seated and retained properly.
- 4 Position the tube and nut squarely on the face seal end of the fitting and tighten the nut finger tight.
- 5 Tighten the nut or fitting to the appropriate torque per given size as shown in the table.
- 6 Operate all machine functions and inspect the hoses and fittings and related components to confirm that there are no leaks.

JIC 37° fittings

- 1 Align the tube flare (hex nut) against the nose of the fitting body (body hex fitting) and tighten the hex nut to the body hex fitting to hand-tight, approximately 30 in-lbs / 3.4 Nm.
- 2 Make a reference mark on one of the flats of the hex nut, and continue it on to the body hex fitting with a permanent ink marker. Refer to Figure 1.

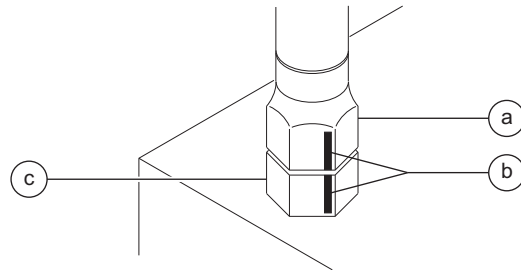

Figure 1

- a hex nut
- b reference mark
- c body hex fitting

- 3 Working clockwise on the body hex fitting, make a second mark with a permanent ink marker to indicate the proper tightening position. Refer to Figure 2.

Note: Use the *JIC 37° Fittings* table on the previous page to determine the correct number of flats for the proper tightening position.

Note: The marks indicate that the correct tightening positions have been determined. Use the second mark on the body hex fitting to properly tighten the joint after it has been loosened.

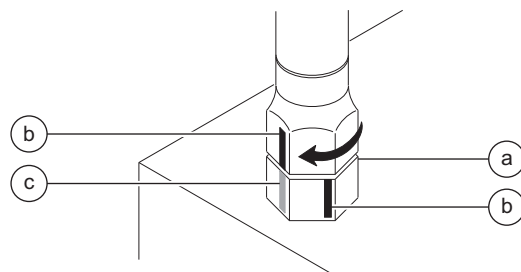







Figure 2

- a body hex fitting
- b reference mark
- c second mark

- 4 Tighten the hex nut until the mark on the hex nut is aligned with the second mark on the body hex fitting.
- 5 Operate all machine functions and inspect the hoses and fittings and related components to confirm that there are no leaks.

SPECIFICATIONS

SAE FASTENER TORQUE CHART											
• This chart is to be used as a guide only unless noted elsewhere in this manual •											
SIZE	THREAD	Grade 5 				Grade 8 				A574 High Strength Black Oxide Bolts	
		LUBED		DRY		LUBED		DRY		LUBED	
		in-lbs	Nm	in-lbs	Nm	in-lbs	Nm	in-lbs	Nm	in-lbs	Nm
1/4	20	80	9	100	11.3	110	12.4	140	15.8	130	14.7
	28	90	10.1	120	13.5	120	13.5	160	18	140	15.8
		LUBED		DRY		LUBED		DRY		LUBED	
		ft-lbs	Nm	ft-lbs	Nm	ft-lbs	Nm	ft-lbs	Nm	ft-lbs	Nm
5/16	18	13	17.6	17	23	18	24	25	33.9	21	28.4
	24	14	19	19	25.7	20	27.1	27	36.6	24	32.5
3/8	16	23	31.2	31	42	33	44.7	44	59.6	38	51.5
	24	26	35.2	35	47.4	37	50.1	49	66.4	43	58.3
7/16	14	37	50.1	49	66.4	50	67.8	70	94.7	61	82.7
	20	41	55.5	55	74.5	60	81.3	80	108.4	68	92.1
1/2	13	57	77.3	75	101.6	80	108.4	110	149	93	126
	20	64	86.7	85	115	90	122	120	162	105	142
9/16	12	80	108.4	110	149	120	162	150	203	130	176
	18	90	122	120	162	130	176	170	230	140	189
5/8	11	110	149	150	203	160	217	210	284	180	244
	18	130	176	170	230	180	244	240	325	200	271
3/4	10	200	271	270	366	280	379	380	515	320	433
	16	220	298	300	406	310	420	420	569	350	474
7/8	9	320	433	430	583	450	610	610	827	510	691
	14	350	474	470	637	500	678	670	908	560	759
1	8	480	650	640	867	680	922	910	1233	770	1044
	12	530	718	710	962	750	1016	990	1342	840	1139
1 1/8	7	590	800	790	1071	970	1315	1290	1749	1090	1477
	12	670	908	890	1206	1080	1464	1440	1952	1220	1654
1 1/4	7	840	1138	1120	1518	1360	1844	1820	2467	1530	2074
	12	930	1260	1240	1681	1510	2047	2010	2725	1700	2304
1 1/2	6	1460	1979	1950	2643	2370	3213	3160	4284	2670	3620
	12	1640	2223	2190	2969	2670	3620	3560	4826	3000	4067

METRIC FASTENER TORQUE CHART																
• This chart is to be used as a guide only unless noted elsewhere in this manual •																
Size (mm)	Class 4.6 				Class 8.8 				Class 10.9 				Class 12.9 			
	LUBED		DRY		LUBED		DRY		LUBED		DRY		LUBED		DRY	
	in-lbs	Nm	in-lbs	Nm	in-lbs	Nm	in-lbs	Nm	in-lbs	Nm	in-lbs	Nm	in-lbs	Nm	in-lbs	Nm
5	16	1.8	21	2.4	41	4.63	54	6.18	58	6.63	78	8.84	68	7.75	91	10.3
6	19	3.05	36	4.07	69	7.87	93	10.5	100	11.3	132	15	116	13.2	155	17.6
7	45	5.12	60	6.83	116	13.2	155	17.6	167	18.9	223	25.2	195	22.1	260	29.4
	LUBED		DRY		LUBED		DRY		LUBED		DRY		LUBED		DRY	
	ft-lbs	Nm	ft-lbs	Nm	ft-lbs	Nm	ft-lbs	Nm	ft-lbs	Nm	ft-lbs	Nm	ft-lbs	Nm	ft-lbs	Nm
8	5.4	7.41	7.2	9.88	14	19.1	18.8	25.5	20.1	27.3	26.9	36.5	23.6	32	31.4	42.6
10	10.8	14.7	14.4	19.6	27.9	37.8	37.2	50.5	39.9	54.1	53.2	72.2	46.7	63.3	62.3	84.4
12	18.9	25.6	25.1	34.1	48.6	66	64.9	88	69.7	94.5	92.2	125	81	110	108	147
14	30.1	40.8	40	54.3	77.4	105	103	140	110	150	147	200	129	175	172	234
16	46.9	63.6	62.5	84.8	125	170	166	226	173	235	230	313	202	274	269	365
18	64.5	87.5	86.2	117	171	233	229	311	238	323	317	430	278	377	371	503
20	91	124	121	165	243	330	325	441	337	458	450	610	394	535	525	713
22	124	169	166	225	331	450	442	600	458	622	612	830	536	727	715	970
24	157	214	210	285	420	570	562	762	583	791	778	1055	682	925	909	1233

Scheduled Maintenance Procedures



Observe and Obey:

- ☑ Maintenance inspections shall be completed by a person trained and qualified on the maintenance of this machine.
- ☑ Scheduled maintenance inspections shall be completed daily, quarterly and semi-annually as specified on the *Maintenance Inspection Report*. The frequency and extent of periodical examinations and tests may also depend on national regulations.

⚠ WARNING Failure to properly complete each inspection when required may cause death, serious injury or substantial machine damage.

- ☑ Immediately tag and remove from service a damaged or malfunctioning machine.
- ☑ Repair any machine damage or malfunction before operating the machine.
- ☑ Use only Genie approved replacement parts.
- ☑ Machines that have been out of service for a period longer than 3 months must complete the quarterly inspection.
- ☑ Unless otherwise specified, perform each maintenance procedure with the machine in the following configuration:
 - Machine disconnected from tow vehicle
 - Machine parked on a firm, level surface
 - Boom in the stowed position with both latches secured
 - Key switch in the off position with the key removed
 - Wheels chocked
 - Parking brake applied

About This Section

This section contains detailed procedures for each scheduled maintenance inspection.

Each procedure includes a description, safety warnings and step-by-step instructions.

Symbols Legend



Safety alert symbol—used to alert personnel to potential personal injury hazards. Obey all safety messages that follow this symbol to avoid possible injury or death.



Indicates an imminently hazardous situation which, if not avoided, will result in death or serious injury.



Indicates a potentially hazardous situation which, if not avoided, could result in death or serious injury.



Indicates a potentially hazardous situation which, if not avoided, may cause minor or moderate injury.



Indicates a potentially hazardous situation which, if not avoided, may result in property damage.

⦿ Indicates that a specific result is expected after performing a series of steps.

⊗ Indicates that an incorrect result has occurred after performing a series of steps.

SCHEDULED MAINTENANCE PROCEDURES

Maintenance Symbols Legend

The following symbols have been used in this manual to help communicate the intent of the instructions. When one or more of the symbols appears at the beginning of a maintenance procedure, it conveys the meaning below.



Indicates that tools will be required to perform this procedure.



Indicates that new parts will be required to perform this procedure.



Indicates that a cold engine will be required to perform this procedure.



Indicates that a warm engine will be required to perform this procedure.



Indicates that dealer service is required to perform this procedure.

Pre-delivery Preparation Report

The pre-delivery preparation report contains checklists for each type of scheduled inspection.

Make copies of the *Pre-delivery Preparation* report to use for each inspection. Store completed forms as required.

Maintenance Schedule

There are five types of maintenance inspections that must be performed according to a schedule—daily, quarterly, semi-annually, annually, and two year. The *Scheduled Maintenance Procedures Section and the Maintenance Inspection Report* have been divided into five subsections—A, B, C, D, and E. Use the following chart to determine which group(s) of procedures are required to perform a scheduled inspection.

Inspection	Checklist
Daily or every 8 hours	A
Quarterly or every 250 hours or every 3000 miles / 4800 km	A + B
Semi-annually or every 500 hours or every 6000 miles / 9600 km	A + B + C
Annually or every 1000 hours or every 12,000 miles / 19,300 km	A + B + C + D
Two year or every 2000 hours	A + B + C + D + E

Maintenance Inspection Report

The maintenance inspection report contains checklists for each type of scheduled inspection.

Make copies of the *Maintenance Inspection Report* to use for each inspection. Maintain completed forms for a minimum of 4 years or in compliance with employer, jobsite and governmental regulations and requirements.

Pre-Delivery Preparation

Fundamentals

It is the responsibility of the dealer to perform the Pre-delivery Preparation.

The Pre-delivery Preparation is performed prior to each delivery. The inspection is designed to discover if anything is apparently wrong with a machine before it is put into service.

A damaged or modified machine must never be used. If damage or any variation from factory delivered condition is discovered, the machine must be tagged and removed from service.

Repairs to the machine may only be made by a qualified service technician, according to the manufacturer's specifications.

Scheduled maintenance inspections shall be performed by qualified service technicians, according to the manufacturer's specifications and the requirements listed in the responsibilities manual.

Instructions

Use the operator's manual on your machine.

The Pre-delivery Preparation consists of completing the Pre-operation Inspection, the Maintenance items and the Function Tests.

Use this form to record the results. Place a check in the appropriate box after each part is completed. Follow the instructions in the operator's manual.

If any inspection receives an N, remove the machine from service, repair and re-inspect it. After repair, place a check in the R box.

Legend

Y = yes, completed

N = no, unable to complete

R = repaired

Comments

Pre-Delivery Preparation	Y	N	R
Pre-operation inspection completed			
Maintenance items completed			
Function tests completed			

Model

Serial number

Date

Machine owner

Inspected by (print)

Inspector signature

Inspector title

Inspector company



Terex South Dakota, Inc USA
500 Oak Wood Road
PO Box 1150
Watertown, SD 57201-6150
(605) 882-4000

Genie UK
The Maltings, Wharf Road
Grantham, Lincolnshire
NG31-6BH England
(44) 1476-584333

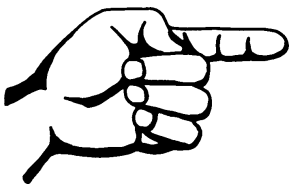

This page intentionally left blank.

Maintenance Inspection Report

Model
Serial number
Date
Hour meter
Machine owner
Inspected by (print)
Inspector signature
Inspector title
Inspector company

- Instructions**
- Make copies of this report to use for each inspection.
 - Select the appropriate checklist(s) for the type of inspection to be performed.

<input type="checkbox"/>	Daily or 8 hours Inspection:	A
<input type="checkbox"/>	Quarterly or 250 hours or 3000 mile / 4800 km Inspection:	A+B
<input type="checkbox"/>	Semi-annually or 500 hours or 6000 mile / 9600 km Inspection:	A+B+C
<input type="checkbox"/>	Annually or 1000 hours or 12,000 mile / 19,300 km Inspection:	A+B+C+D
<input type="checkbox"/>	Two year or 2000 hours Inspection:	A+B+C+D+E

- Place a check in the appropriate box after each inspection procedure is completed.
- Use the step-by-step procedures in this section to learn how to perform these inspections.
- If any inspection receives an "N", tag and remove the machine from service, repair and re-inspect it. After repair, place a check in the "R" box.

Legend
 Y = yes, acceptable
 N = no, remove from service
 R = repaired

Comments

Checklist A	Y	N	R
A-1 Manuals and Decals			
A-2 Pre-operation inspect			
A-3 Function tests			
A-4 Engine maintenance (if equipped)			
A-5 Lug bolts			
A-6 Lug bolts			
A-7 Hitch maintenance			
A-8 Engine maintenance (if equipped)			
Perform after 40 hours:			
A-9 Perform 30 day service			
Perform every 50 hours:			
A-10 Engine maintenance (if equipped)			
Perform every 100 hours:			
A-11 Grease rotate bearing			
A-12 Engine maintenance (if equipped)			

Checklist B	Y	N	R
B-1 Batteries			
B-2 Electrical wiring			
B-3 Electrical Contactor			
B-4 Emergency Stop			
B-5 Key switch			
B-6 Manual override			
B-7 Hydraulic oil analysis			
B-8 Axle maintenance			
B-9 Tongue jack			
B-10 Parking brake			
B-11 Wheel bearings			
B-12 Hitch			
B-13 Axle maintenance			
Perform every 300 hours:			
B-14 Engine maintenance (if equipped)			

Checklist C	Y	N	R
C-1 Grease platform overload (if equipped)			
C-2 Test platform overload (if equipped)			
C-3 Axle maintenance			
C-4 Breather Cap			
C-5 Axle wheel bearings			
C-6 Brakes			

Checklist D	Y	N	R
D-1 Axle maintenance			
D-2 Boom wear pads			
D-3 Hydraulic return filter			
D-4 Turntable bearing bolts			
D-5 Turntable bearing wear			

Checklist E - Rev A	Y	N	R
E-1 Hydraulic oil			
E-2 Engine maintenance (if equipped)			



Checklist A Procedures

A-1 Inspect the Manuals and Decals

Genie specifications require that this procedure be performed daily or every 8 hours, whichever comes first.

Maintaining the operator's and safety manuals in good condition is essential to safe machine operation. Manuals are included with each machine and should be stored in the container provided in the platform. An illegible or missing manual will not provide safety and operational information necessary for a safe operating condition.

In addition, maintaining all of the safety and instructional decals in good condition is mandatory for safe machine operation. Decals alert operators and personnel to the many possible hazards associated with using this machine. They also provide users with operation and maintenance information. An illegible decal will fail to alert personnel of a procedure or hazard and could result in unsafe operating conditions.

- 1 Check to make sure that the operator's and safety manuals are present and complete in the storage container on the platform.
 - 2 Examine the pages of each manual to be sure that they are legible and in good condition.
- ⦿ Result: The operator's manual is appropriate for the machine and all manuals are legible and in good condition.
 - ✗ Result: The operator's manual is not appropriate for the machine or all manuals are not in good condition or are illegible. Remove the machine from service until the manual is replaced.

- 3 Open the operator's manual to the decals inspection section. Carefully and thoroughly inspect all decals on the machine for legibility and damage.
- ⦿ Result: The machine is equipped with all required decals, and all decals are legible and in good condition.
 - ✗ Result: The machine is not equipped with all required decals, or one or more decals are illegible or in poor condition. Remove the machine from service until the decals are replaced.
- 4 Always return the manuals to the storage container after use.

Note: Contact your authorized Genie distributor or Genie if replacement manuals or decals are needed.

CHECKLIST A PROCEDURES

A-2 Perform Pre-operation Inspection

Completing a Pre-operation Inspection is essential to safe machine operation. The Pre-operation Inspection is a visual inspection performed by the operator prior to each work shift. The inspection is designed to discover if anything is apparently wrong with a machine before the operator performs the function tests. The Pre-operation Inspection also serves to determine if routine maintenance procedures are required.

Complete information to perform this procedure is available in the appropriate operator's manual. Refer to the Operator's Manual on your machine.

A-3 Perform Function Tests

Completing the function tests is essential to safe machine operation. Function tests are designed to discover any malfunctions before the machine is put into service. A malfunctioning machine must never be used. If malfunctions are discovered, the machine must be tagged and removed from service.

Complete information to perform this procedure is available in the appropriate operator's manual. Refer to the Operator's Manual on your machine.

A-4 Perform Engine Maintenance (if equipped)



Engine specifications require that this procedure be performed every 8 hours or daily, whichever comes first.

- Check oil level
- Check air cleaner

Required maintenance procedures and additional engine information is available in the *Honda GX160 Engine Owner Manual* (Honda part number 31ZH7630).

Honda GX160 Owner's Manual

Genie part number

97228

CHECKLIST A PROCEDURES

A-5 Torque the Lug Bolts - Electrical and Hydraulic Axles



Axle specifications require that this procedure be performed initially after 10, 25 and 50 miles.

Proper axle maintenance, following the axle manufacturer's maintenance schedule, is essential to good axle performance and service life. Failure to perform the maintenance procedures can lead to poor axle performance and component damage.

- 1 Check each lug bolt for proper torque. Refer to Section 2, *Specifications*.

Required maintenance procedures and additional axle information is available in the *Dexter Axle Operation Maintenance Service Manual* (Dexter part number LIT-001-00).

Dexter Axle Operation Maintenance Service Manual
Genie part number 84376

A-6 Torque the Lug Bolts - Mechanical Axle



Axle specifications require that this procedure be performed initially after 50 km, or 50 km after a wheel change.

Proper axle maintenance, following the axle manufacturer's maintenance schedule, is essential to good axle performance and service life. Failure to perform the maintenance procedures can lead to poor axle performance and component damage.

- 1 Check each lug bolt for proper torque. Refer to Section 2, *Specifications*.

Required maintenance procedures and additional axle information is available in the *KNOTT Axle Service Manual* (KNOTT part number P005).

KNOTT Axle Service Manual
Genie part number 84443

CHECKLIST A PROCEDURES

**A-7
Perform Hitch Maintenance -
Hydraulic Axle**



Hitch specifications require that this procedure be performed weekly.

- Brake fluid level
- Inspect actuator

Required maintenance procedures and additional hitch information is available in the *Demco Model 91 Brake Actuators Owner/Operator Manual* (Demco part number BH20023).

Demco Model 91 Owner/Operator Manual
Genie part number 84592

**A-8
Perform Engine Maintenance
(if equipped)**



Engine specifications require that this procedure be performed initially at 20 hours or 30 days, whichever comes first.

- Replace engine oil

Required maintenance procedures and additional engine information is available in the *Honda GX160 Engine Owner Manual* (Honda part number 31ZH7630).

Honda GX160 Owner's Manual
Genie part number 97228

CHECKLIST A PROCEDURES

A-9 Perform 30 Day Service



The 30 day maintenance procedure is a onetime procedure to be performed after the first 30 days or 40 hours of usage. After this interval, refer to the maintenance tables for continued scheduled maintenance.

1 Perform the following maintenance procedures:

- A-11 Grease the Turntable Rotation Bearing and Rotate Gear
- B-7 Check the Turntable Rotation Bearing Bolts
- B-10 Inspect the Parking Brake
- D-4 Replace the Hydraulic Tank Return Filter

A-10 Perform Engine Maintenance (if equipped)



Engine specifications require that this procedure be performed every 50 hours or quarterly, whichever comes first. Perform this procedure more often if dusty conditions exist.

- Air filter

Required maintenance procedures and additional engine information is available in the *Honda GX160 Engine Owner Manual* (Honda part number 31ZH7630).

Honda GX160 Owner's Manual

Genie part number

97228

CHECKLIST A PROCEDURES

A-11 Grease the Turntable Rotation Bearing and Rotate Gear



Genie specifications require that this procedure be performed every 100 hours of operation.

Regular application of lubrication to the turntable bearing and rotate gear is essential to good machine performance and service life. Continued use of an insufficiently greased bearing and gear will result in component damage.

- 1 Raise the boom enough to access the turntable bearing.
- 2 **Before serial number TZ5004-391:** Locate the grease fitting on the inside of the turntable rotation bearing.
After serial number TZ5004-390: Locate the grease fitting below the ground control box.
- 3 Pump multipurpose grease into the turntable rotation bearing. Rotate the turntable in increments of 4 to 5 inches / 10 to 13 cm at a time and repeat this step until the entire bearing has been greased.
- 4 Apply grease to each tooth of the drive gear located under the turntable.

Grease type	Multipurpose grease
--------------------	---------------------

A-12 Perform Engine Maintenance (if equipped)



Engine specifications require that this procedure be performed every 6 months or every 100 hours, whichever comes first. Perform this procedure more often if dusty conditions exist.

- Replace engine oil
- Clean fuel sediment cup
- Check/clean spark plug

Required maintenance procedures and additional engine information is available in the *Honda GX160 Engine Owner Manual* (Honda part number 31ZH7630).

Honda GX160 Owner's Manual	
Genie part number	97228

Checklist B Procedures

B-1

Inspect the Batteries



Proper battery condition is essential to good machine performance and operational safety. Improper fluid levels or damaged cables and connections can result in component damage and hazardous conditions.

⚠ WARNING Electrocutation hazard. Contact with electrically charged circuits could result in death or serious injury. Remove all rings, watches and other jewelry.

⚠ WARNING Bodily injury hazard. Batteries contain acid. Avoid spilling or contacting battery acid. Neutralize battery acid spills with baking soda and water.

Note: Perform this procedure after fully charging the batteries.

Note: For a more accurate determination of battery condition, fully charge the batteries and allow the batteries to rest 24 hours before performing this procedure to allow the battery cells to equalize.

- 1 Put on protective clothing and eye wear.
- 2 Be sure that the battery cable connections are free of corrosion.

- 3 Be sure that the battery retaining fasteners and cable connections are tight.
- 4 Remove the battery vent caps from all batteries and check the specific gravity of each battery cell with a hydrometer.
 - ⦿ Result: If any battery cell displays a specific gravity of less than 1.026, the battery must be replaced.
- 5 Check the battery acid level of each battery. If needed, replenish with distilled water to the bottom of the battery fill tube. Do not overfill.
- 6 Install the battery vent caps.
- 7 Check each battery pack and verify that the batteries are wired correctly.

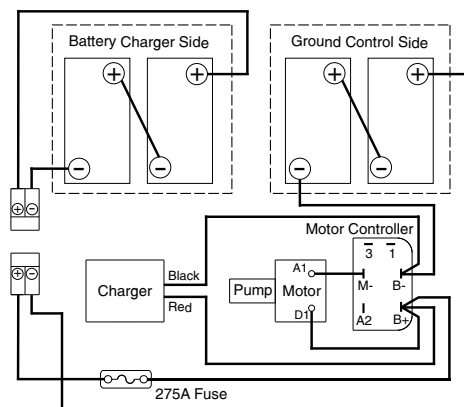

- 8 Inspect the battery charger plug and pigtail for damage or excessive insulation wear. Replace as required.

CHECKLIST B PROCEDURES

- 9 Connect the battery charger to a properly grounded 115V/60Hz or 230V/60Hz single phase AC power supply.
- ⦿ Result: The charger should operate and begin charging the batteries.
- ⊗ Result: Simultaneously, the charger alarm sounds and the LED's blink **one time**. Correct the charger connections at the fuse and battery. The charger will then operate correctly and begin charging the batteries.
- ⊗ Result: Simultaneously, the charger alarm sounds and the LED's blink **two times**. The input voltage is too low or too high. Correct the voltage issue. The charger will then operate correctly and begin charging the batteries.
- ⊗ Result: Simultaneously, the charger alarm sounds and the LED's blink **three times**. The charger is overheated. Allow the charger to cool. The charger will then operate correctly and begin charging the batteries.

Note: If you have any further questions regarding the battery charger operation, please contact Genie Product Support.

B-2 Inspect the Electrical Wiring

Maintaining electrical wiring in good condition is essential to safe operation and good machine performance. Failure to find and replace burnt, chafed, corroded or pinched wires could result in unsafe operating conditions and may cause component damage.

⚠ WARNING Electrocution hazard. Contact with hot or live circuits could result in death or serious injury. Remove all rings, watches and other jewelry.

- 1 Inspect the following areas for burnt, chafed, corroded and loose wires:
 - Turntable area
 - Ground controls
 - Power unit wiring
- 2 Turn the key switch to ground control and pull out the red Emergency Stop button to the on position at both the ground and platform controls.
- 3 Raise the secondary boom until the platform is approximately 10 feet / 3 m off the ground.
- 4 Inspect the boom storage area for burnt, chafed and pinched cables.
- 5 Lower the boom to the stowed position and turn the machine off.
- 6 Inspect the following areas for burnt, chafed, corroded, pinched and loose wires:
 - Boom to platform cable harness
 - Primary and secondary booms

CHECKLIST B PROCEDURES

B-3 Inspect the Electrical Contactor



Genie requires that this procedure be performed every 250 hours or quarterly, whichever comes first.

Maintaining the electrical contactor in good condition is essential to safe machine operation. Failure to locate a worn or damaged contactor could result in an unsafe working condition and component damage.

- 1 At the ground controls, turn the key switch to the off position and push in the red Emergency Stop button to the off position.
- 2 Disconnect the batteries.
- 3 Locate the electrical contactor mounted on the fuse bracket.
- 4 Visually inspect the contact points of the contactor for the following items:
 - Excessive burns
 - Excessive arcs
 - Excessive pitting

⚠ WARNING Electrocutation/burn hazard. Contact with hot or live circuits could result in death or serious injury. Remove all rings, watches and other jewelry.

Note: Replace the contactor if any damage is found.

B-4 Test the Emergency Stop

A properly functioning Emergency Stop is essential for safe machine operation. An improperly operating red Emergency Stop button will fail to shut off power and stop all machine functions, resulting in a hazardous situation.

- 1 Turn the key switch to ground control and pull out the red Emergency Stop button to the on position at both the ground and platform controls. Pull out the red Emergency Stop button to the on position at the drive controls (if equipped).

- 2 Push in the red Emergency Stop button at the ground controls to the off position.

⊙ Result: No machine functions should operate.

Note: The red Emergency Stop button at the ground controls will stop all machine operation without regard to the position of the key switch.

- 3 Turn the key switch to platform control and pull out the red Emergency Stop button to the on position at the ground controls.
- 4 Push down the red Emergency Stop button at the platform controls to the off position.

⊙ Result: No machine functions should operate.

Models with drive (option):

- 5 Pull out the red Emergency Stop button to the on position at the platform controls.
- 6 Push down the red Emergency Stop button at the drive controls to the off position.

⊙ Result: The drive function should not operate.

CHECKLIST B PROCEDURES

B-5 Test the Key Switch

Proper key switch action and response is essential to safe machine operation. The machine can be operated from the ground or platform controls and the activation of one or the other is accomplished with the key switch. Failure of the key switch to activate the appropriate control panel could cause a hazardous operating situation.

Note: Perform this procedure from the ground using the platform controls. Do not stand in the platform.

- 1 Pull out the red Emergency Stop button to the on position at both the ground and platform controls. Pull out the red Emergency Stop button to the on position at the drive controls (if equipped).
- 2 Turn the key switch to **platform control**.
- 3 Check the machine functions from the **ground controls**.
 - ⊙ Result: The machine functions should **not** operate.
- 4 Check the machine functions from the **drive controls**.
 - ⊙ Result: The drive functions should operate.
- 5 Turn the key switch to **ground control**.
- 6 Check the machine functions from the **platform controls**.
 - ⊙ Result: The machine functions should **not** operate.
- 7 Check the machine functions from the **drive controls**.
 - ⊙ Result: The drive functions should operate.
- 8 Turn the key switch to the off position.
 - ⊙ Result: No function should operate.

B-6 Test the Manual Override

Testing the manual override for malfunctions is essential for safe machine operation. An unsafe working condition exists if the manual override function does not operate in the event of a main power loss.

Turntable Rotate

- 1 Locate the turntable rotate valve coils on the function manifold. Push in and hold the red thumbscrew at the center of the valve stem.
 - ⊙ Result: The head of the thumbscrew should move $\frac{1}{4}$ inch / 6 mm inwards.

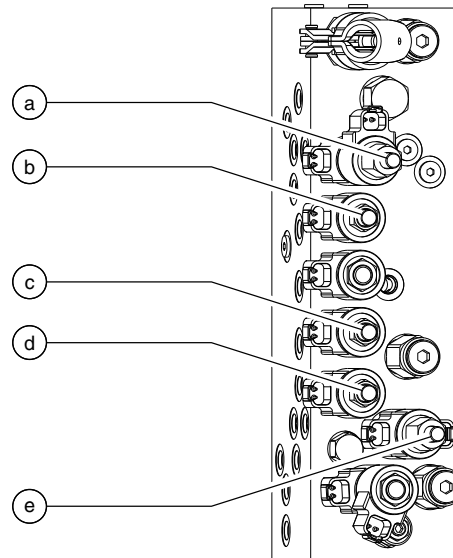

- a turntable rotate valve
- b secondary boom down valve
- c primary boom down valve
- d primary boom up valve
- e boom extend/retract valve

- 2 Release the red thumbscrew at the center of the valve stem, to reset the valve.

Note: The valve spool must be reset for the turntable rotate function to operate from the machine controls.

CHECKLIST B PROCEDURES

- 3 Pull out and hold the red thumbscrew at the center of the valve stem.
- ⊙ Result: The head of the thumbscrew should move $\frac{1}{4}$ inch / 6 mm outwards.
- 4 Release the red thumbscrew at the center of the valve stem, to reset the valve.

Note: The valve spool must be reset for the turntable rotate function to operate from the machine controls.

Secondary Boom Down

- 5 Locate the secondary boom down valve coil on the function manifold. Push in and turn fully in a counter clockwise direction the red thumbscrew at the center of the valve stem.
- ⊙ Result: The head of the thumbscrew should rotate one-quarter turn in a counter clockwise direction.
- 6 Push in and turn fully in a clockwise direction the red thumbscrew at the center of the valve stem, to reset the valve.

Note: The valve spool must be reset for the secondary boom down function to operate from the machine controls.

Primary Boom Down

- 7 Locate the primary boom down valve coil on the function manifold. Push in and turn fully in a counter clockwise direction the red thumbscrew at the center of the valve stem.
- ⊙ Result: The head of the thumbscrew should rotate one-quarter turn in a counter clockwise direction.
- 8 Push in and turn fully in a clockwise direction the red thumbscrew at the center of the valve stem, to reset the valve.

Note: The valve spool must be reset for the primary boom down function to operate from the machine controls.

Primary Boom Up

- 9 Locate the primary boom up valve coil on the function manifold. Push in and turn fully in a counter clockwise direction the red thumbscrew at the center of the valve stem.
- ⊙ Result: The head of the thumbscrew should rotate one-quarter turn in a counter clockwise direction.
- 10 Push in and turn fully in a clockwise direction the red thumbscrew at the center of the valve stem, to reset the valve.

Note: The valve spool must be reset for the primary boom up function to operate from the machine controls.

CHECKLIST B PROCEDURES

Boom Extend/Retract

- 11 Locate the boom extend/retract valve coils on the function manifold. Push in and hold the red thumbscrew at the center of the valve stem.
- ⦿ Result: The head of the thumbscrew should move $\frac{1}{4}$ inch / 6 mm inwards.
- 12 Release the red thumbscrew at the center of the valve stem, to reset the valve.
- Note: The valve spool must be reset for the turntable rotate function to operate from the machine controls.
- 13 Locate the boom extend/retract valve coils on the function manifold. Pull out and hold the red thumbscrew at the center of the valve stem.
- ⦿ Result: The head of the thumbscrew should move $\frac{1}{4}$ inch / 6 mm outwards.
- 14 Release the red thumbscrew at the center of the valve stem, to reset the valve.

Note: The valve spool must be reset for the turntable rotate function to operate from the machine controls.

B-7**Perform Hydraulic Oil Analysis**

Replacement or testing of the hydraulic oil is essential for good machine performance and service life. Dirty oil may cause the machine to perform poorly and continued use may cause component damage. Extremely dirty conditions may require oil changes to be performed more often.

Note: Before replacing the hydraulic oil, the oil may be tested by an oil distributor for specific levels of contamination to verify that changing the oil is necessary. **If the hydraulic oil is not replaced at the two year inspection, test the oil quarterly. Replace the oil when it fails the test.** See E-1, *Test or Replace the Hydraulic Oil*.

CHECKLIST B PROCEDURES

B-8 Perform Axle Maintenance - Electrical and Hydraulic Axles



Axle specifications require that this procedure be performed quarterly or every 3000 miles, whichever comes first.

- Brake Adjustment

Required maintenance procedures and additional axle information is available in the *Dexter Axle Operation Maintenance Service Manual* (Dexter part number LIT-001-00).

Dexter Axle Operation Maintenance Service Manual
Genie part number 84376

B-9 Service the Tongue Jack



Maintaining the tongue jack in good condition is essential to safe operation and good machine performance. Failure to lubricate the internal gears and bearings of the jack and axle bolt could result in unsafe operating conditions and may cause component damage.

Jack specifications require that this procedure be performed quarterly or every 3000 miles, whichever comes first.

- 1 Remove the cap from the top of the jack housing and, using automotive grease, lightly grease the internal gears. Rotate the handle to evenly distribute the lubricant to the internal gears.
- 2 Securely install the cap onto the jack.

CHECKLIST B PROCEDURES

B-10 Inspect the Parking Brake



A properly functioning parking brake is essential to safe machine operation. The parking brake is manually activated. An improperly functioning parking brake will prevent the operator from properly securing the machine when not in use.

ANSI models without drive option:

- 1 Visually inspect the parking brake cables and components for damage.
- 2 Visually inspect the parking brake cables to ensure both are properly secured and installed into the brake backing plate.
- 3 Set the parking brake.

Note: If the brake cables are too tight the parking brake assembly will be difficult to apply. If the brake cables are too loose, the brakes will not activate when the lever is set.

- 4 Attempt to manually push the machine.

⊙ Result: The machine should not move.

⊗ Result: The machine moves. Proceed to step 5.

- 5 Chock the wheels
- 6 Release the parking brake.

- 7 Loosen the set screw at the side of the parking brake handle.
 - 8 Adjust the handle just to the point where it is difficult to apply the parking brake, then rotate the top of the parking brake handle counterclockwise one full turn.
 - 9 Tighten the set screw. Do not overtighten.
 - 10 Engage the parking brake. Attempt to move the machine in both directions.
- ⊙ Result: The parking brake should prevent the machine from moving. If the parking brake does not prevent the machine from moving, repeat steps 5 through 8 until the adjustment is correct OR see B-8, *Perform Axle Maintenance - Electrical and Hydraulic Axles*

CE models without drive option:

- 1 Visually inspect the parking brake cables and components for damage.
- 2 Visually inspect the parking brake cables to ensure both are properly secured and installed into the brake backing plate.
- 3 Set the parking brake.

Note: If the brake cables are too tight the parking brake assembly will be difficult to apply. If the brake cables are too loose, the brakes will not activate when the lever is set.

- 4 Attempt to manually push the machine.

⊙ Result: The machine should not move.

⊗ Result: The machine moves. Proceed to step 5.

CHECKLIST B PROCEDURES

- 5 At the ground controls, extend the outriggers until the axle is off the ground and the machine is level.
 - 6 Release the parking brake.
 - 7 Pull out the nose of the hitch as far as it will go.
 - 8 Loosen the lock nuts at the tension equalizer.
 - 9 Turn the wheel in a forward motion, adjusting the wheel brakes until the wheel turns with difficulty or not at all.
 - 10 Adjust the wheel brakes until the wheel turns freely.
- Note: Slight rubbing noises, which do not affect the free turning of the wheel, are permitted.
- 11 Repeat steps 9 and 10 for the other wheel.
 - 12 Engage and release the parking brake 4 times.
 - 13 Tighten the nuts on the tension equalizer bracket until the bracket is balanced. Securely tighten the lock nuts.
 - 14 Adjust the linkage until it is free of play and without initial tension.
 - 15 Lower the machine and return the outriggers to the stowed position.

- 16 Engage the parking brake. Attempt to move the machine in both directions.

- ☉ Result: The parking brake should prevent the machine from moving.
- ☒ If the parking brake does not prevent the machine from moving, repeat steps 5 through 16 until adjustment is correct OR see B-13, Perform Axle Maintenance - Mechanical Axles.

ANSI models with drive option:

- 1 Visually inspect the parking brake cables and components for damage.
- 2 Visually inspect the parking brake cables to ensure all are properly secured and installed into the brake backing plate and parking brake balance bar.
- 3 Set the parking brake.

Note: If the brake cables are too tight the parking brake assembly will be difficult to apply. If the brake cables are too loose, the brakes will not activate when the lever is set.

- 4 Attempt to manually push the machine.
- ☉ Result: The machine should not move.
 - ☒ Result: The machine moves. Proceed to step 5.

CHECKLIST B PROCEDURES

- 5 Adjust the brakes. See B-8, Perform Axle Maintenance - Electrical and Hydraulic Axles
- 6 Chock the wheels
- 7 Release the parking brake.
- 8 Loosen the set screw at the side of the parking brake handle.
- 9 Adjust the handle just to the point where it is difficult to apply the parking brake, then rotate the top of the parking brake handle counterclockwise one full turn.
- 10 Tighten the set screw. Do not overtighten.
- 11 At the ground controls, extend the outriggers until the axle is off the ground and the machine is level.
- 12 Engage the parking brake.
- 13 Remove the parking brake cylinder inspection cover.
- 14 Adjust the parking brake cylinder input cable until the cylinder flange just contacts the cylinder slider assembly.

Models to TZ5006-510

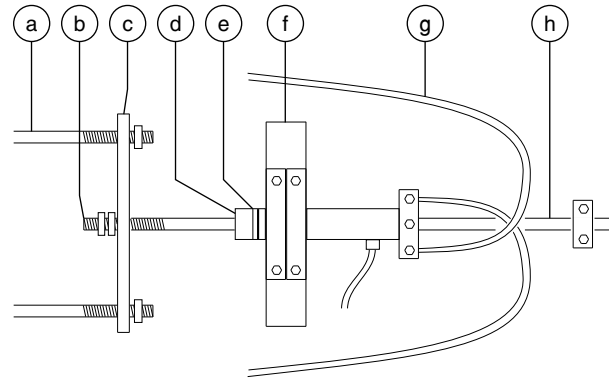

Models from TZ5006-511

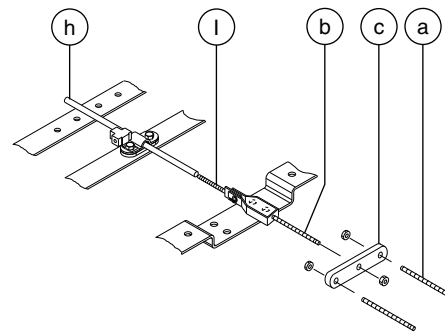

- a rear (chassis) parking brake cable
- b cylinder output rod / threaded rod
- c tension equalizer bracket
- d parking brake cylinder
- e cylinder flange
- f slider assembly
- g drive motor brake cable
- h cylinder input cable / parking brake cable
- i threaded rod

CHECKLIST B PROCEDURES

15 Release the parking brake.

16 Adjust both rear parking brake cables at the tension equalizer bracket until, when turning the wheel in the direction of travel, a slight rubbing noise can be heard from the brakes. Loosen the cables just until no noise can be heard when turning the wheels.

Note: Be sure a minimum of one full thread of the cable end is showing through the adjustment nut at the tension equalizer bracket.

17 Tighten the nuts on the tension equalizer bracket until the bracket is balanced. Securely tighten the lock nuts.

18 Engage the parking brake.

19 Engage both drive motors.

20 Working from the front end of the parking brake cylinder, adjust the drive motor brake cables by hand until they have zero play and zero resistance. Be sure the brake cylinder balancebar is square to the parking brake input cable.

21 Disengage both drive motors.

22 Engage the parking brake. Attempt to move the machine in both directions.

⊙ Result: The parking brake should prevent the machine from moving.

⊗ If the parking brake does not prevent the machine from moving, repeat this procedure beginning with step 5.

CE models with drive option:

- 1 Visually inspect the parking brake cables and components for damage.
- 2 Visually inspect the parking brake cables to ensure all are properly secured and installed into the brake backing plate and parking brake balance bar.
- 3 Set the parking brake.

Note: If the brake cables are too tight the parking brake assembly will be difficult to apply. If the brake cables are too loose, the brakes will not activate when the lever is set.

- 4 Attempt to manually push the machine.
- ⊙ Result: The machine should not move.
- ⊗ Result: The machine moves. Proceed to step 5.
- 5 At the ground controls, extend the outriggers until the axle is off the ground and the machine is level.
- 6 Release the parking brake.
- 7 Pull out the nose of the hitch as far as it will go.
- 8 Remove the parking brake cylinder inspection cover.

CHECKLIST B PROCEDURES

- 9 Visually inspect the parking brake cables to ensure all are properly secured and installed into the brake backing plate and tension equalizer bracket.

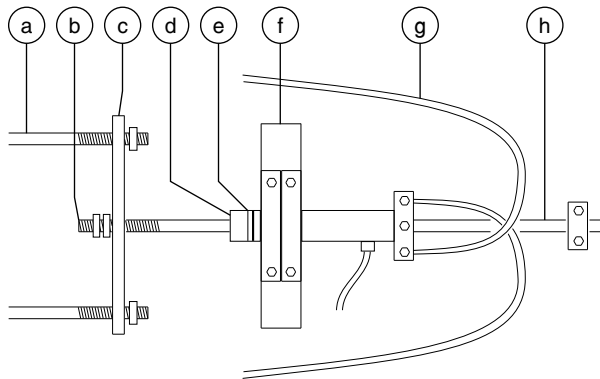
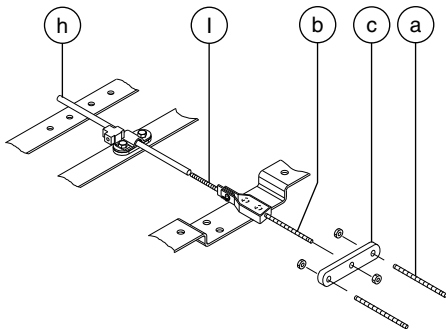
Models to TZ5006-510**Models from TZ5006-511**

- a rear (chassis) parking brake cable
- b cylinder output rod / threaded rod
- c tension equalizer bracket
- d parking brake cylinder
- e cylinder flange
- f slider assembly
- g drive motor brake cable
- h cylinder input cable / parking brake cable
- i threaded rod

- 10 Loosen the lock nuts at the tension equalizer bracket.
- 11 Turn the wheel in a forward motion, adjusting the wheel brakes until the wheel turns with difficulty or not at all.
- 12 Adjust the wheel brakes until the wheel turns freely.

Note: Slight rubbing noises, which do not affect the free turning of the wheel, are permitted.

- 13 Repeat steps 11 and 12 for the other wheel.
- 14 Engage and release the parking brake 4 times.
- 15 Engage the parking brake.
- 16 Adjust the parking brake cylinder input cable until the cylinder flange just contacts the cylinder slider assembly.

- 17 Release the parking brake.

- 18 Adjust both rear parking brake cables at the tension equalizer bracket until, when turning the wheel in the direction of travel, a slight rubbing noise can be heard from the brakes. Loosen the cables just until no noise can be heard when turning the wheels.

Note: Be sure a minimum of one full thread of the cable end is showing through the adjustment nut at the tension equalizer bracket.

CHECKLIST B PROCEDURES

- 19 Tighten the nuts on the tension equalizer bracket until the bracket is balanced. Securely tighten the lock nuts.
- 20 Engage the parking brake.
- 21 Engage both drive motors.
- 22 Working from the front end of the parking brake cylinder, adjust the drive motor brake cables by hand until they have zero play and zero resistance. Be sure the brake cylinder balance bar is square to the parking brake input cable.
- 23 Disengage both drive motors.
- 24 Engage the parking brake. Attempt to move the machine in both directions.
- ⦿ Result: The parking brake should prevent the machine from moving.
- ✗ If the parking brake does not prevent the machine from moving, repeat this procedure beginning with step 5.

B-11

Check the Wheel Bearings - Mechanical Axle



Axle specifications require that this procedure be performed quarterly or every 5000 km, whichever comes first.

Proper axle maintenance, following the axle manufacturer's maintenance schedule, is essential to good axle performance and service life. Failure to perform the maintenance procedures can lead to poor axle performance and component damage.

- 1 At the ground controls, extend the outriggers until the axle is off the ground and the machine is level.
 - 2 Check for wheel bearing wear by attempting to move the wheel hub side to side, then up and down.
- ⦿ Result: There should be no side to side or up and down movement.
- ✗ Result: There is side to side or up and down movement. See C-5, Grease the Axle Wheel Bearings - Mechanical Axle.

Required maintenance procedures and additional axle information is available in the *KNOTT Axle Service Manual* (KNOTT part number P005).

KNOTT Axle Service Manual

Genie part number

84443

CHECKLIST B PROCEDURES

B-12

Service the Hitch - Mechanical Axle



Axle specifications require that this procedure be performed quarterly or every 5000 km, whichever comes first.

Proper axle maintenance, following the axle manufacturer's maintenance schedule, is essential to good axle performance and service life. Failure to perform the maintenance procedures can lead to poor axle performance and component damage.

- 1 Clean all visible surfaces of the ball coupler.
- 2 Lubricate the hitch at both grease fittings at the top of the over-run hitch.
- 3 Lubricate all bolts and articulated points on the hand brake lever using commonly available machine oil or motor oil.
- 4 Lubricate all bolts and movable parts of the coupler using commonly available machine oil or motor oil.

- 5 Lightly grease the ball mount.
 - 6 Confirm that the brake cable is securely installed into the brake handle linkage.
 - 7 Apply the hand brake.
 - 8 Attempt to manually push the machine.
- ⦿ Result: The machine does not move.
 - ⦿ Result: The machine moves. Adjust the brakes. See Maintenance procedure C-6, *Adjust the Brakes - Mechanical Axle*.

Required maintenance procedures and additional axle information is available in the *KNOTT Axle Service Manual* (KNOTT part number P005).

KNOTT Axle Service Manual

Genie part number

84443

CHECKLIST B PROCEDURES

B-13 Perform Axle Maintenance - Mechanical Axles



Axle specifications require that this procedure be performed annually or every 5000 km, whichever comes first.

- Brake Inspection
- Axle Inspection

Required maintenance procedures and additional axle information is available in the *KNOTT Axle Service Manual* (KNOTT part number P005).

KNOTT Axle Service Manual

Genie part number 84443

B-14 Perform Engine Maintenance (if equipped)



Engine specifications require that this procedure be performed every 300 hours or annually, whichever comes first.

- Fuel tank and strainer
- Valve clearance

Required maintenance procedures and additional engine information is available in the *Honda GX160 Engine Owner Manual* (Honda part number 31ZH7630) and the *Honda GX160 Engine Shop Manual* (Honda part number 61ZH700).

Honda GX160 Owner's Manual

Genie part number 97228

Honda GX160 Shop Manual

Genie part number 97229

Checklist C Procedures

C-1 Grease the Platform Overload Mechanism (if equipped)



Genie specifications require that this procedure be performed every 500 hours or 6 months, whichever comes first. Perform this procedure more often if dusty conditions exist.

Application of lubrication to the platform overload mechanism is essential to safe machine operation. Continued use of an improperly greased platform overload mechanism could result in the system not sensing an overloaded platform condition and will result in component damage.

- 1 Locate the grease fittings on each pivot pin of the platform overload assembly.
- 2 Thoroughly pump grease into each grease fitting.

Grease type	Multipurpose grease
--------------------	---------------------

C-2 Test the Platform Overload System (if equipped)



Genie specifications require that this procedure be performed every 500 hours or 6 months, whichever comes first.

Testing the platform overload system regularly is essential to safe machine operation. Continued use of an improperly operating platform overload system could result in the system not sensing an overloaded platform condition. Machine stability could be compromised resulting in the machine tipping over.

Note: Perform this procedure with the machine on a firm, level surface.

- 1 At the ground controls, extend the outriggers until the axle is off the ground and the machine is level.
 - 2 Release the boom hold down latch.
 - 3 Turn the key switch to platform control.
 - 4 Level the platform.
 - 5 Determine the maximum platform capacity. Refer to the machine serial plate.
 - 6 Using a suitable lifting device, place an appropriate test weight equal to that of the maximum platform capacity in the center of the platform floor.
- ⊙ **Result:** The platform overload indicator light should be off at both the ground and platform controls.

CHECKLIST C PROCEDURES

- 7 Add an additional 44 lbs / 20 kg of weight to overload the platform.
- ⦿ Result: The platform overload indicator light should be flashing at both the ground and platform controls.
- 8 Test all machine functions from the platform controls.
- ⦿ Result: All platform control functions should not operate.
- 9 Turn the key switch to ground control.
- 10 Test all machine functions from the ground controls.
- ⦿ Result: All ground control functions should not operate.
- 11 Lift the test weight off the platform floor using a suitable lifting device.
- ⦿ Result: The platform overload indicator light should turn off at both the ground and platform controls.
- 12 Test all machine functions from the ground controls.
- ⦿ Result: All ground control functions should operate normally.
- 13 Turn the key switch to platform control.
- 14 Test all machine functions from the platform controls.
- ⦿ Result: All platform control functions should operate.

Note: If the platform overload system is not operating properly, refer to Repair Procedure 13-1, *Calibrate the Platform Overload System (if equipped)*.

C-3

Perform Axle Maintenance - Electrical and Hydraulic Axles



Axle specifications require that this procedure be performed every 6 months or 6000 miles, whichever comes first.

- Brake Magnets
- Brake Controller
- Suspension Components

Required maintenance procedures and additional axle information is available in the *Dexter Axle Operation Maintenance Service Manual* (Dexter part number LIT-001-00).

Dexter Axle Operation Maintenance Service Manual	
Genie part number	84376

CHECKLIST C PROCEDURES

C-4

Replace the Hydraulic Tank Breather Cap - Models with Optional Hydraulic Oil



The hydraulic tank is a vented-type tank. The breather cap has an internal air filter that can become clogged or, over time, can deteriorate. If the breather cap is faulty or improperly installed, impurities can enter the hydraulic system which may cause component damage. Extremely dirty conditions may require that the cap be inspected more often.

- 1 Remove and discard the hydraulic tank breather cap.
- 2 Install a new cap onto the tank.

C-5

Grease the Axle Wheel Bearings Mechanical Axle



Axle specifications require that this procedure be performed every 6 months or 10,000 km, whichever comes first.

Maintaining the axle wheel bearings is essential to safe operation and good machine performance. Towing the machine with loose or worn wheel bearings may cause an unsafe towing condition and continued use may result in component or property damage. Regular steam cleaning and pressure washing of the machine may require that this procedure be performed more often.

- 1 Loosen the wheel lug bolts. Do not remove them.
- 2 At the ground controls, extend the outriggers until the axle is off the ground and the machine is level.
- 3 Remove the lug bolts and remove the tire and wheel assembly from the machine.
- 4 Remove, wash and inspect the axle wheel bearings and spacer ring.
- 5 Pack both bearings with clean, fresh grease.
- 6 Install the bearings and spacer ring onto the axle and reassemble the axle.

CHECKLIST C PROCEDURES

- 7 Tighten the castle nut until the wheel runs with a little bite.
- 8 Loosen the castle nut just until the cotter pin fits into the next hole. Install a new cotter pin and lock into position. Install the dust cap.

Note: Always replace the cotter pin with a new one when removing the castle nut or when checking the torque of the castle nut.

- 9 Install the tire and wheel onto the axle. Install and torque the lug bolts to specification. Refer to Section 2, *Specifications*.
- 10 Perform steps 3 through 9 for the other side of the machine.
- 11 Return the outriggers to the stowed position.

Required maintenance procedures and additional axle information is available in the *KNOTT Axle Service Manual* (KNOTT part number P005).

KNOTT Axle Service Manual

Genie part number

84443

C-6 Adjust the Brakes - Mechanical Axle



Axle specifications require that this procedure be performed every 6 months or 10,000 km, whichever comes first.

Proper axle maintenance, following the axle manufacturer's maintenance schedule, is essential to good axle performance and service life. Failure to perform the maintenance procedures can lead to poor axle performance and component damage.

- 1 At the ground controls, extend the outriggers until the axle is off the ground and the machine is level.
- 2 Release the parking brake.
- 3 Working from the exposed inside face of the brake plate, opposite the cable entry, tighten the adjusting screw until the wheel can only be turned with difficulty or not at all.

Note: When tighten the adjusting screw, turn the wheel only in the direction of travel.

- 4 Ease off the adjusting screw approximately one-half turn in a counterclockwise direction, until the wheel turns freely.

CHECKLIST C PROCEDURES

- 5 Repeat steps 3 through 4 for the other brake.
- 6 Inspect the balance plate at the control cables.
- ⊙ Result: The balance plate is at a right angle to the direction of towing.
- ⊗ Result: The balance plate is not at a right angle to the direction of towing. Tighten or loosen the brake cable ends coming from the axle until the balance plate is at a right angle to the direction of towing.

Note: The balance plate is located beneath the diamond plate cover in front of the turntable.

- 7 Return the outriggers to the stowed position.
- 8 Apply the parking brake.
- 9 Attempt to manually push the machine.
- ⊙ Result: The machine does not move.
- ⊗ Result: The machine moves. Repeat this procedure beginning with step 1.
- ⊗ Result: One wheel rolls and the other one doesn't. Repeat step 6 and adjust the balance plate to tighten the brake cable from the wheel which is rolling.

Required maintenance procedures and additional axle information is available in the *KNOTT Axle Service Manual* (KNOTT part number P005).

KNOTT Axle Service Manual

Genie part number

84443

Checklist D Procedures

D-1 Perform Axle Maintenance - Electric and Hydraulic Axles



Axle specifications require that this procedure be performed every 12 months or 12,000 miles, whichever comes first.

- Brake lining
- Brake cylinders
- Brake lines
- Trailer brake wiring
- Hub/Drum
- Wheel bearings
- Seals
- Springs
- Hangers

Required maintenance procedures and additional axle information is available in the *Dexter Axle Operation Maintenance Service Manual* (Dexter part number LIT-001-00).

Dexter Axle Operation Maintenance Service Manual
Genie part number 84376

D-2 Check the Boom Wear Pads



Maintaining the boom wear pads in good condition is essential to safe machine operation. Wear pads are placed on boom tube surfaces to provide a low friction, replaceable wear pad between moving parts. Improperly shimmed wear pads or continued use of extremely worn wear pads may result in component damage and unsafe operating conditions.

Note: If the wear pads are within specification, refer to Repair Procedure 3-2, *How to Shim the Boom*.

- 1 Extend the boom until the wear pads are accessible.
- 2 Measure the thickness of the top, side and bottom wear pads. If the wear pad is within specification, shim as necessary to obtain zero clearance and zero drag.
- 3 Extend and retract the boom through the entire range of motion to check for tight spots that may cause binding or scraping of the boom.

Note: Always maintain squareness between the outer and inner boom tubes.

Boom wear pad specifications

Wear pad thickness, minimum	$\frac{7}{16}$ inch 11 mm
-----------------------------	------------------------------

CHECKLIST D PROCEDURES

D-3**Replace the Hydraulic Tank Return Filter**

Replacement of the hydraulic tank return filter element is essential for good machine performance and service life. A dirty or clogged filter element may cause the machine to perform poorly and continued use may cause component damage. Extremely dirty conditions may require that the filter element be replaced more often.

CAUTION Burn hazard. Beware of hot oil. Contact with hot oil may cause severe burns.

Note: The hydraulic filter is mounted on the bulkhead next to the hydraulic tank.

- 1 Clean the area around the hydraulic oil filter. Remove the filter with an oil filter wrench.

WARNING Bodily injury hazard. Spraying hydraulic oil can penetrate and burn skin. Loosen hydraulic connections very slowly to allow the oil pressure to dissipate gradually. Do not allow oil to squirt or spray.

- 2 Apply a thin layer of fresh oil onto the gasket of the new oil filter.

- 3 Install the filter and tighten it securely by hand.
- 4 Use a permanent ink marker to write the date and number of hours from the hour meter on the new filter.
- 5 Clean up any oil that may have spilled during the replacement procedure. Properly discard the used filter.
- 6 Turn the key switch to ground controls and pull out the red Emergency Stop button to the on position at both the ground and platform controls.
- 7 Raise the platform approximately 3 ft / 1 m.
- 8 Inspect the filter and related components to be sure that there are no leaks.

CHECKLIST D PROCEDURES

D-4 Check the Turntable Rotation Bearing Bolts



Maintaining proper torque on the turntable bearing bolts is essential to safe machine operation. Improper bolt torque or torque sequence could result in an unsafe operating condition and component damage.

- 1 Be sure that each turntable rotation bearing mounting bolt above the turntable is torqued in sequence to specification. Refer to Illustration 1.

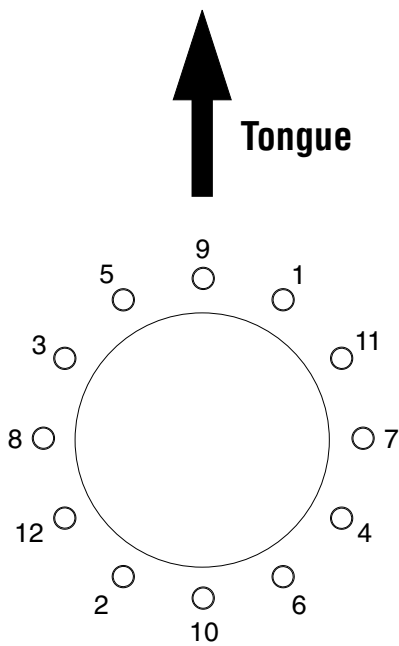

Illustration 1

Bearing-to-swing chassis bolt torque sequence

- 2 Working from underneath the turntable, be sure that each turntable rotation bearing mounting bolt is torqued in sequence to specification. Refer to Illustration 2.

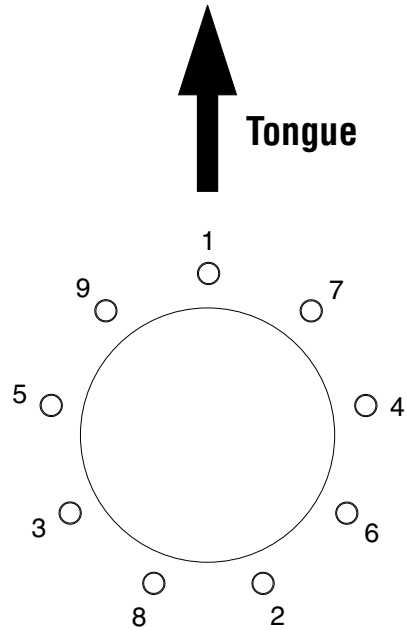

Illustration 2

Bearing-to-chassis bolt torque sequence

Turntable rotation bearing bolt torque specifications

Bearing to chassis, lubricated	195 ft-lbs 264 Nm
Bearing to swing chassis, lubricated	195 ft-lbs 264 Nm

CHECKLIST D PROCEDURES

D-5 Inspect for Turntable Bearing Wear



Periodic inspection of turntable bearing wear is essential to safe machine operation, good machine performance and service life. Continued use of a worn turntable bearing could create an unsafe operating condition, resulting in death or serious injury and component damage.

Note: Perform this procedure with the machine on a firm, level surface and the boom in the stowed position.

- 1 Grease the turntable bearing. See A-13, *Grease the Turntable Rotation Bearing and Rotate Gear*.
- 2 Torque the turntable bearing bolts to specification. See D-2, *Check the Turntable Rotation Bearing Bolts*.
- 3 Start the machine from the ground controls and raise the primary and secondary booms to full height. Do not extend the primary boom.
- 4 Place a dial indicator between the drive chassis and the turntable at a point that is directly under, or inline with, the boom and no more than 1 inch / 2.5 cm from the bearing.

Note: To obtain an accurate measurement, place the dial indicator no more than 1 inch / 2.5 cm from the turntable rotation bearing.

- 5 At the dial indicator, adjust it to "zero" the indicator.

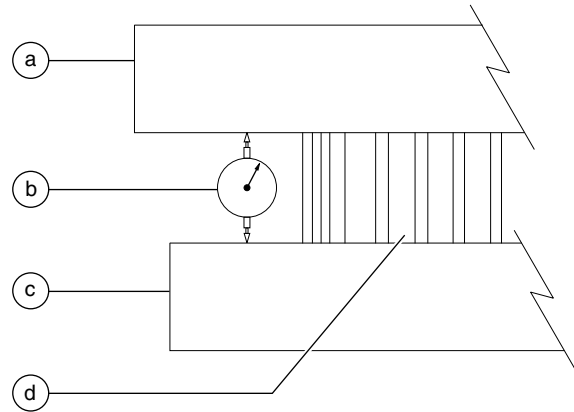

- a turntable
- b dial indicator
- c drive chassis
- d turntable rotation bearing

- 6 Lower the secondary boom to the stowed position and lower the primary boom to a horizontal position. Fully extend the primary boom.
- 7 Note the reading on the dial indicator.
 - ⊙ **Result:** The measurement is less than 0.025 inch / 0.635 mm. The bearing is good.
 - ✗ **Result:** The measurement is more than 0.025 inch / 0.635 mm. The bearing is worn and needs to be replaced.
- 8 Fully retract the primary boom. Raise the primary and secondary booms to full height. Visually inspect the dial indicator to be sure the needle returns to the "zero" position.
- 9 Remove the dial indicator and rotate the turntable 90°.
- 10 Repeat steps 4 through 9 until the rotation bearing has been checked in at least four equally spaced areas 90° apart.
- 11 Lower the primary and secondary booms to the stowed position and turn the machine off.
- 12 Remove the dial indicator from the machine.

Checklist E Procedures

E-1

Test or Replace the Hydraulic Oil



Replacement or testing of the hydraulic oil is essential for good machine performance and service life. Dirty oil and suction strainers may cause the machine to perform poorly and continued use may cause component damage. Extremely dirty conditions may require oil changes to be performed more often.

Note: Before replacing the hydraulic oil, the oil may be tested by an oil distributor for specific levels of contamination to verify that changing the oil is necessary. **If the hydraulic oil is not replaced at the two year inspection, test the oil quarterly. Replace the oil when it fails the test.**

Note: When removing a hose assembly or fitting, the O-ring on the fitting and/or hose end must be replaced and then torqued to specification during installation. Refer to Section 2, *Hydraulic Hose and Fitting Torque Specifications*.

Note: Perform this procedure with the machine in the stowed position.

- 1 Disconnect the battery pack from the machine.

WARNING Electrocutation hazard. Contact with hot or live circuits could result in death or serious injury. Remove all rings, watches and other jewelry.

- 2 Remove the drain plug from the hydraulic tank and completely drain the tank into a suitable container. Refer to Section 2, *Specifications*, for capacity information.

WARNING Bodily injury hazard. Spraying hydraulic oil can penetrate and burn skin. Loosen hydraulic connections very slowly to allow the oil pressure to dissipate gradually. Do not allow oil to squirt or spray.

- 3 Tag and disconnect the hydraulic return line from the filter head to tank.
- 4 Tag and disconnect the hydraulic inlet line to the filter head. Cap the fitting on the line.
- 5 Remove the filter head from the machine.
- 6 Tag and disconnect the hydraulic line from the tank to the pump. Cap the fitting on the pump.
- 7 Remove the hydraulic tank mounting fasteners. Remove the hydraulic tank from the machine.
- 8 Clean the inside of the hydraulic tank using a mild solvent.
- 9 Install and tighten the hydraulic tank drain plug using thread sealer on the threads. Torque to specification.

Torque specifications

Hydraulic tank drain plug, dry	150 in-lbs 16.9 Nm
Hydraulic tank drain plug, lubricated	112 in-lbs 12.6 Nm

CHECKLIST E PROCEDURES

10 Install the hydraulic tank and install and tighten the hydraulic tank mounting fasteners. Torque to specification.

Torque specifications

Hydraulic tank mounting fasteners, dry	35 in-lbs 4 Nm
Hydraulic tank mounting fasteners, lubricated	26 in-lbs 2.9 Nm

11 Install the hydraulic line onto the inlet side of the hydraulic pump.

12 Install the hydraulic filter head onto the machine and securely tighten the fasteners. Do not over tighten.

13 Install the hydraulic lines into the filter head.

14 Connect the battery pack to the machine.

15 Fill the hydraulic tank with hydraulic oil until the fluid is at the FULL mark on the tank. Do not overfill. Refer to Section 2, *Specifications*.

16 Activate the pump to fill the hydraulic system with oil and bleed the system of air.

NOTICE Component damage hazard. The pump can be damaged if operated without oil. Be careful not to empty the hydraulic tank while in the process of filling the hydraulic system.

17 Repeat steps 15 through 16 until the hydraulic system and tank are both full. Inspect for leaks.

18 Clean up any oil that may have spilled.

E-2 Perform Engine Maintenance (if equipped)



Engine specifications require that this procedure be performed every two years.

- Fuel line

Required maintenance procedures and additional engine information is available in the *Honda GX160 Engine Shop Manual* (Honda part number 61ZH700)

Honda GX160 Shop Manual

Genie part number

97229

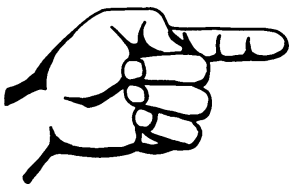

This page intentionally left blank.

Repair Procedures



Observe and Obey:

- ☑ Repair procedures shall be completed by a person trained and qualified on the repair of this machine.
- ☑ Immediately tag and remove from service a damaged or malfunctioning machine.
- ☑ Repair any machine damage or malfunction before operating the machine.

Before Repairs Start:

- ☑ Read, understand and obey the safety rules and operating instructions in the appropriate *Genie TZ-50* Operator's Manual on your machine.
- ☑ Be sure that all necessary tools and parts are available and ready for use.
- ☑ Use only Genie approved replacement parts.
- ☑ Read each procedure completely and adhere to the instructions. Attempting shortcuts may produce hazardous conditions.
- ☑ Unless otherwise specified, perform each repair procedure with the machine in the following configuration:
 - Machine disconnected from tow vehicle
 - Machine parked on a firm, level surface
 - Boom in the stowed position with both latches secured
 - Key switch in the off position with the key removed
 - Wheels chocked
 - Parking brake applied

About This Section

Most of the procedures in this section should only be performed by a trained service professional in a suitably equipped workshop. Select the appropriate repair procedure after troubleshooting the problem.

Perform disassembly procedures to the point where repairs can be completed. Then to re-assemble, perform the disassembly steps in reverse order.

Symbols Legend



Safety alert symbol—used to alert personnel to potential personal injury hazards. Obey all safety messages that follow this symbol to avoid possible injury or death.

▲ DANGER

Indicates an imminently hazardous situation which, if not avoided, will result in death or serious injury.

▲ WARNING

Indicates a potentially hazardous situation which, if not avoided, could result in death or serious injury.

▲ CAUTION

Indicates a potentially hazardous situation which, if not avoided, may cause minor or moderate injury.

NOTICE

Indicates a potentially hazardous situation which, if not avoided, may result in property damage.

⦿ Indicates that a specific result is expected after performing a series of steps.

⊗ Indicates that an incorrect result has occurred after performing a series of steps.

Platform Components

1-1 Platform

How to Remove the Platform

- 1 Tag and disconnect the taillight control cable at the front of the platform.
- 2 Remove the platform control box retaining fasteners. Remove the platform control box from the platform and set it to the side.

NOTICE Component damage hazard. Cables and hoses can be damaged if they are kinked or pinched.

- 3 Support and secure the platform to an appropriate lifting device. Do not apply any lifting pressure.
- 4 Remove the fasteners securing the platform to the lower side of the platform mount.
- 5 Remove the fasteners and pin securing the platform to the platform mount.

WARNING Crushing hazard. The platform could become unbalanced and fall if not properly supported when the pin is removed.

- 6 Remove the platform from the platform mount.

1-2 Platform Rotator

The platform rotator is a hydraulically-operated helical gear assembly used to rotate the platform 160°.

How to Remove the Platform Rotator (if equipped)

- 1 Remove the platform. See 1-1, *How to Remove the Platform*.
- 2 Raise the jib boom 4 to 5 feet / 1.2 to 1.5 m.
- 3 Lower the jib boom until the platform mount rests on sawhorses or a work table of sufficient capacity.
- 4 Remove the wire harness from the platform mount. Set the platform controls and wire harness cables to the side.
- 5 Tag, disconnect and plug the hydraulic hoses to the platform rotator. Cap the fittings on the rotator.

WARNING Bodily injury hazard. Spraying hydraulic oil can penetrate and burn skin. Loosen hydraulic connections very slowly to allow the oil pressure to dissipate gradually. Do not allow oil to squirt or spray.

- 6 Attach a lifting strap of suitable capacity from an overhead crane to the platform mount. Support the mount. Do not apply any lifting pressure.

PLATFORM COMPONENTS

- 7 Remove the pin retaining fasteners securing the platform mount pivot pins.
- 8 Using a soft metal drift, remove the platform mount pivot pins. Remove the platform mount from the machine.

⚠WARNING Crushing hazard. The platform mount could fall if not properly supported when the pivot pin is removed.

How to Bleed the Platform Rotator

- 1 Activate the platform rotate right function and rotate the platform completely to the right. Continue to activate the rotate right function for 3 seconds.
- 2 Activate the platform rotate left function and rotate the platform completely to the left. Continue to activate the rotate left function for 3 seconds.

Jib Boom Components

2-1 Jib Boom

The jib boom lift cylinder raises and lowers the jib boom. The jib boom lift cylinder is equipped with a counterbalance valve to prevent movement in the event of a hydraulic line failure.

How to Remove the Jib Boom

Note: When removing a hose assembly or fitting, the O-ring (if equipped) on the fitting and/or the hose end must be replaced. All connections must be torqued to specification during installation. Refer to Section 2, *Hydraulic Hose and Fitting Torque Specifications*.

- 1 Remove the platform. See 1-1, *How to Remove the Platform*.
- 2 Raise the jib boom 4 to 5 feet / 1.2 to 1.5 m.
- 3 Lower the jib boom until the platform mount rests on sawhorses or a work table of sufficient capacity.
- 4 Tag and disconnect the wire harness from the platform control box.
- 5 Tag and disconnect the wires from the jib manifold.
- 6 Remove the wire harness from the platform mount and the jib boom.
- 7 Pull the all harness cables through the jib boom and lay them off to the side of the primary boom.

NOTICE Component damage hazard. Cables and hoses can be damaged if they are kinked or pinched.

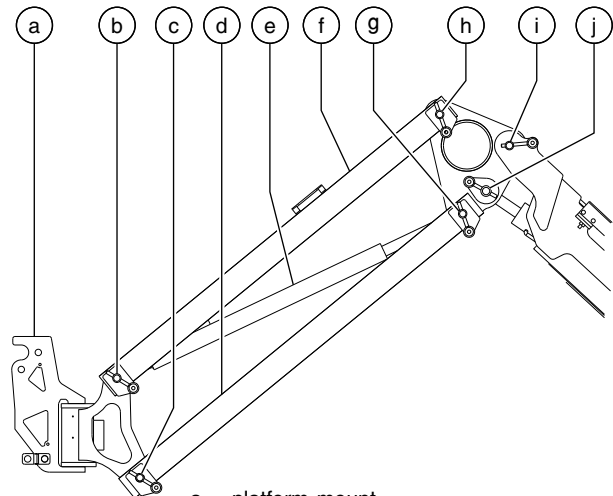

- a platform mount
- b jib boom cylinder barrel-end pivot pin
- c jib link pivot pin
- d jib link
- e jib boom lift cylinder
- f jib boom
- g jib boom cylinder rod-end pivot pin
- h jib boom pivot pin
- i jib mount pivot pin
- j platform level slave cylinder rod end pivot pin

- 8 Tag, disconnect and plug the hydraulic hoses to the platform rotator. Cap the fittings on the rotator.

WARNING Bodily injury hazard. Spraying hydraulic oil can penetrate and burn skin. Loosen hydraulic connections very slowly to allow the oil pressure to dissipate gradually. Do not allow oil to squirt or spray.

- 9 Tag, disconnect and plug the hydraulic hoses to the jib cylinder. Cap the fittings on the cylinder.

WARNING Bodily injury hazard. Spraying hydraulic oil can penetrate and burn skin. Loosen hydraulic connections very slowly to allow the oil pressure to dissipate gradually. Do not allow oil to squirt or spray.

JIB BOOM COMPONENTS

10 Attach a lifting strap of suitable capacity from an overhead crane to the platform mount. Support the mount. Do not apply any lifting pressure.

11 Remove the pin retaining fasteners securing the platform mount pivot pins.

12 Using a soft metal drift, remove the platform mount pivot pins. Remove the platform mount from the machine.

▲WARNING Crushing hazard. The platform mount could fall if not properly supported when the pivot pin is removed.

13 Remove the jib manifold retaining fasteners.

NOTICE Component damage hazard. Cables and hoses can be damaged if they are kinked or pinched.

14 Attach a lifting strap of suitable capacity from an overhead crane to the jib boom. Support the jib boom. Do not apply any lifting pressure.

15 Remove the pin retaining fasteners securing the jib boom pivot pins.

16 Using a soft metal drift, remove the jib boom pivot pins. Remove the jib boom from the machine.

▲WARNING Crushing hazard. The platform mount could fall if not properly supported when the pivot pin is removed.

17 Lay the jib manifold and hoses off to the side of the primary boom.

NOTICE Component damage hazard. Cables and hoses can be damaged if they are kinked or pinched.

18 Attach a lifting strap of suitable capacity from an overhead crane to the jib link at the ground control side of the machine. Support the jib link. Do not apply any lifting pressure.

19 Working from the ground control side of the machine, use a soft metal drift to tap the jib link pivot pin halfway out. Remove the jib link from the machine.

▲WARNING Crushing hazard. The jib link could fall if not properly supported when the pivot pin is removed.

20 Attach a lifting strap of suitable capacity from an overhead crane to the remaining jib link. Support the jib link. Do not apply any lifting pressure.

21 Working from the side of the machine opposite the ground controls, use a soft metal drift to tap the jib link pivot pin halfway out. Remove the jib link from the machine.

▲WARNING Crushing hazard. The jib link could fall if not properly supported when the pivot pin is removed.

22 Attach a lifting strap of suitable capacity from an overhead crane to the jib cylinder. Support the cylinder. Do not apply any lifting pressure.

23 Using a soft metal drift, remove the jib cylinder pivot pin. Remove the cylinder from the machine.

▲WARNING Crushing hazard. The cylinder could fall if not properly supported when the pivot pin is removed.

24 Attach a lifting strap of suitable capacity from an overhead crane to the jib mount. Support the mount. Do not apply any lifting pressure.

JIB BOOM COMPONENTS

25 Remove the pin retaining fasteners securing the jib mount pivot pin and the platform level slave cylinder rod end pivot pin.

26 Place a wooden block between the primary boom and the platform level slave cylinder.

27 Using a soft metal drift, remove the platform level slave cylinder rod end pivot pin. Rest the cylinder on the block.

▲WARNING Crushing hazard. The cylinder could fall if not properly supported when the pivot pin is removed.

28 Using a soft metal drift, remove the jib mount pivot pin. Remove the jib mount from the machine.

▲WARNING Crushing hazard. The jib mount could fall if not properly supported when the pivot pin is removed.

2-2

Jib Boom Lift Cylinder

How to Remove the Jib Boom Lift Cylinder

Note: When removing a hose assembly or fitting, the O-ring (if equipped) on the fitting and/or the hose end must be replaced. All connections must be torqued to specification during installation. Refer to Section 2, *Hydraulic Hose and Fitting Torque Specifications*.

- 1 Raise the jib boom 4 to 5 feet / 1.2 to 1.5 m.
- 2 Lower the jib boom until the platform mount rests on sawhorses or a work table of sufficient capacity.
- 3 Tag, disconnect and plug the hydraulic hoses to the jib cylinder. Cap the fittings on the cylinder.

▲WARNING Bodily injury hazard. Spraying hydraulic oil can penetrate and burn skin. Loosen hydraulic connections very slowly to allow the oil pressure to dissipate gradually. Do not allow oil to squirt or spray.

- 4 Attach a lifting strap of suitable capacity from an overhead crane to the platform mount. Support the mount. Do not apply any lifting pressure.
- 5 Attach a lifting strap of suitable capacity from an overhead crane to the jib boom. Support the jib boom. Do not apply any lifting pressure.

JIB BOOM COMPONENTS

- 6 Place a wooden block between the jib cylinder and the jib links.
- 7 Remove the pin retaining fasteners securing the jib boom cylinder barrel end pivot pin.
- 8 Using a soft metal drift, remove the jib boom cylinder barrel end pivot pin. Lower the cylinder onto the wooden block.

▲WARNING Crushing hazard. The jib cylinder could fall if not properly supported when the pivot pin is removed.

▲WARNING Crushing hazard. The jib boom could fall if not properly supported when the pivot pin is removed.

- 9 Install the jib boom onto the platform mount. Install the pivot pin securing the jib boom to the platform mount.
- 10 Attach a lifting strap of suitable capacity from an overhead crane to the jib link at the ground control side of the machine. Support the jib link. Do not apply any lifting pressure.
- 11 Working from the ground control side of the machine, use a soft metal drift to tap the jib link pivot pin halfway out. Lower the jib link.

▲WARNING Crushing hazard. The jib link could fall if not properly supported when the pivot pin is removed.

- 12 Working from the ground control side of the machine, use a soft metal drift to tap the jib link pivot pin out just enough to release the jib cylinder. Remove the cylinder from the machine.

▲WARNING Crushing hazard. The jib cylinder could fall if not properly supported when the pivot pin is removed.

Primary Boom Components

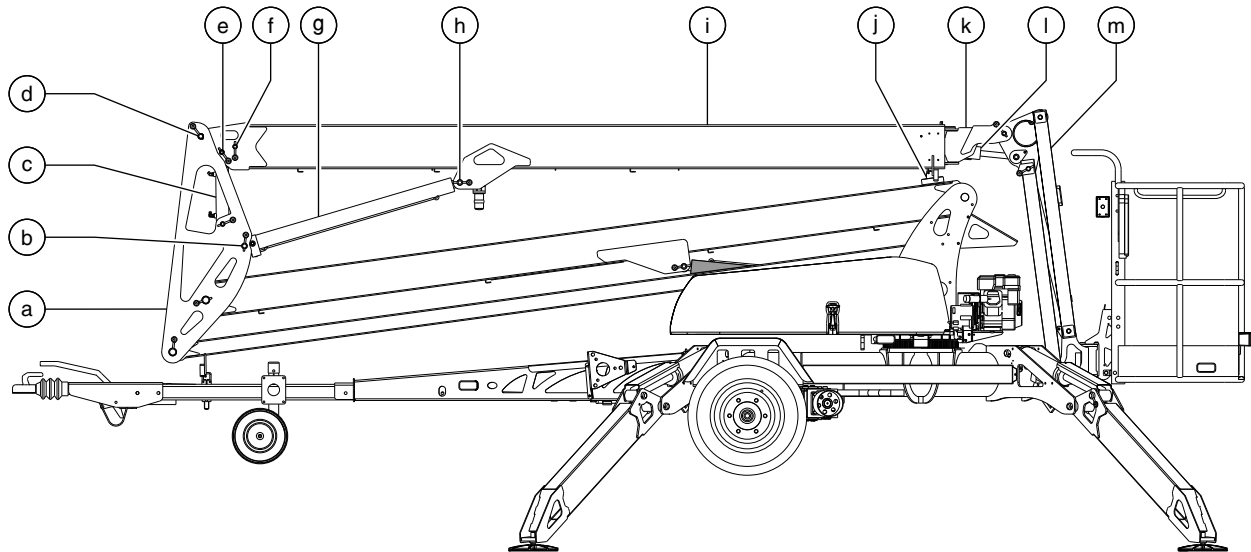

- | | | | |
|---|--|---|---|
| a | mid-pivot | m | jib boom |
| b | primary boom lift cylinder barrel-end pivot pin | n | secondary boom pivot pin |
| c | platform level master cylinder | o | secondary boom link pivot pin |
| d | primary boom pivot pin | p | secondary boom latch |
| e | platform level master cylinder rod-end pivot pin | q | secondary boom |
| f | extension cylinder barrel-end pivot pin | r | secondary boom link |
| g | primary boom lift cylinder | s | secondary lift cylinder rod-end pivot pin |
| h | primary boom lift cylinder rod-end pivot pin | t | secondary boom lift cylinder |
| i | primary boom | u | secondary lift cylinder barrel-end pivot pin
(located behind ground control box) |
| j | primary boom latch | v | turntable |
| k | extension boom | w | secondary boom pivot pin |
| l | platform level slave cylinder | | |

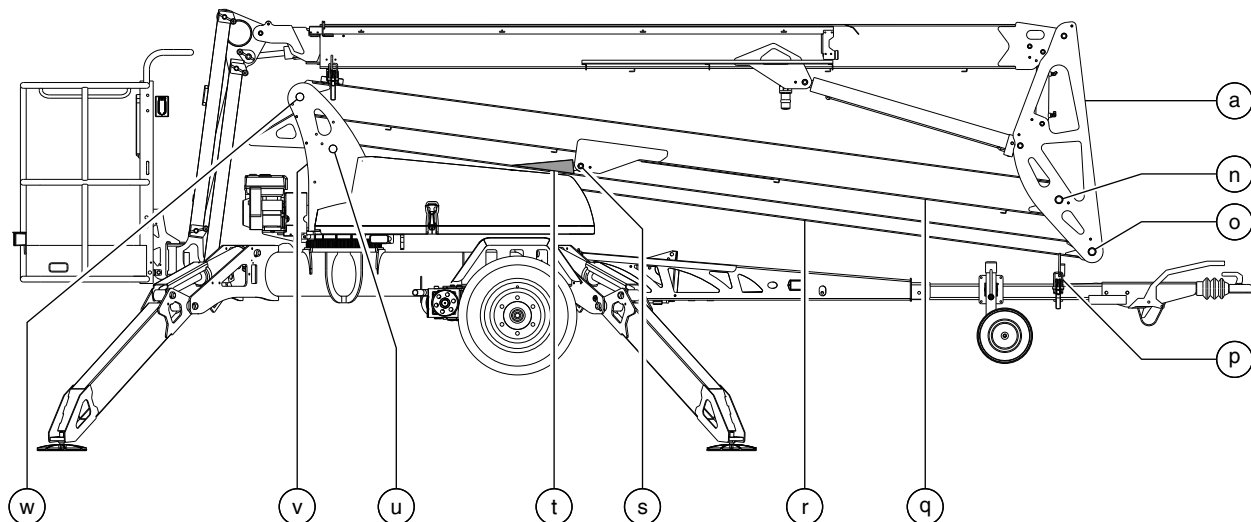

PRIMARY BOOM COMPONENTS

3-1 Cable Track

The boom cable track guides cables and hoses running up the boom. It can be repaired link by link without removing the cables and hoses that run through it. Removing the entire boom cable track may be necessary when performing major repairs that involve removing the boom.

How to Remove the Cable Track

Note: When removing a hose assembly or fitting, the O-ring (if equipped) on the fitting and/or the hose end must be replaced. All connections must be torqued to specification during installation. Refer to Section 2, *Hydraulic Hose and Fitting Torque Specifications*.

- 1 Tag and disconnect the wire harness from the platform control box.
- 2 Tag and disconnect the wires from the jib manifold.
- 3 Remove the wire harness from the platform mount and the jib boom.
- 4 Pull the all harness cables through the jib boom and lay them off to the side of the primary boom.

NOTICE Component damage hazard. Cables and hoses can be damaged if they are kinked or pinched.

- 5 Tag, disconnect and plug the hydraulic hoses at the jib boom end of the cable bridge. Cap the fittings on the hydraulic hard lines. Refer to 'XX' in the illustration below.

WARNING Bodily injury hazard. Spraying hydraulic oil can penetrate and burn skin. Loosen hydraulic connections very slowly to allow the oil pressure to dissipate gradually. Do not allow oil to squirt or spray.

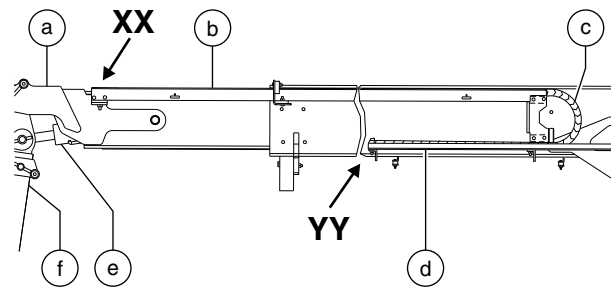

- a extension boom
- b cable bridge
- c cable track
- d track support
- e platform level slave cylinder
- f jib boom

- 6 Tag, disconnect and plug the hydraulic hoses at the lower end of the cable track. Cap the fittings on the hydraulic hard lines. Refer to 'YY' in the illustration above.
- 7 Place blocks between the cable bridge and the cable track and secure them together.

WARNING Crushing hazard. If the cable bridge and the cable track are not properly secured together, the combination could become unbalanced and fall when removed from the machine.

PRIMARY BOOM COMPONENTS

- 8 Attach a lifting strap of suitable capacity from an overhead crane to the rod end of the primary lift cylinder. Support the cylinder. Do not apply any lifting pressure.
- 9 Remove the pin retaining fastener from the primary lift cylinder rod end pivot pin.
- 10 Using a soft metal drift, remove the primary lift cylinder rod end pivot pin.

AWARNING Crushing hazard. The cylinder will fall if not properly supported when the pivot pin is removed.

- 11 Lower the cylinder onto the secondary boom.
- 12 Remove the wire harness cables from the bottom of the primary boom. Secure the hydraulic hard lines to the boom.
- 13 Place blocks between the cable bridge and the cable track. Secure the cable bridge and the cable track together.

AWARNING Crushing hazard. If the cable bridge and the cable track are not properly secured together, the combination could become unbalanced and fall when removed from the machine.

- 14 Attach a lifting strap from an overhead crane to the cable track.
- 15 Remove the mounting fasteners that attach the lower cable track to the boom.
- 16 Remove the cable track from the machine and place it on a structure capable of supporting it.

AWARNING Crushing hazard. The cable track could become unbalanced and fall if not properly attached to the overhead crane.

How to Repair the Cable Track

NOTICE Component damage hazard. The cable track can be damaged if it is twisted.

- 1 Visually inspect the cable track and determine which 7 link section needs to be replaced.
- 2 Using a flat blade screwdriver, pry open the hinge bar on each link of the 7 link section, plus one more on each end making a total of 9.
- 3 Using a flat blade screwdriver at one side of the link to be replaced, separate the connection and open the joint slightly by sliding the link over the link pivot. Repeat for the other side of the link to separate the link sections.
- 4 Repeat step 3 for the other end of the section to be replaced.
- 5 Lift up the hoses and cables and carefully remove the damaged section of cable track.

NOTICE Component damage hazard. Hoses and cables can be damaged if they are kinked or pinched.

- 6 Lift up the hoses and cables and carefully insert the new section of cable track.
- 7 Install the new section of cable track onto the existing track. Be sure the link pivot on both sides of the link are in place and that the track hinges correctly.
- 8 Securely lock the hinge bar for each link.
- 9 Operate the boom extend/retract function through a full cycle to ensure smooth operation of the new section of cable track.

PRIMARY BOOM COMPONENTS

3-2 Primary Boom

How to Shim the Primary Boom

- 1 Extend the boom until the wear pads are accessible.
- 2 Loosen the wear pad mounting fasteners.
- 3 Install the new shims under the wear pad to obtain zero clearance and zero drag.
- 4 Securely tighten the mounting fasteners. Do not over-tighten.
- 5 Extend and retract the boom through an entire cycle. Check for tight spots that could cause binding or scraping.

Note: Always maintain squareness between the outer and inner boom tubes.

How to Remove the Primary Boom

WARNING This procedure requires specific repair skills, lifting equipment and a suitable workshop. Attempting this procedure without these skills and tools could result in death or serious injury and significant component damage. Dealer service is required.

Follow the disassembly steps to the point required to complete the repair. Then re-assemble the secondary boom by following the disassembly steps in reverse order.

Note: When removing a hose assembly or fitting, the O-ring on the fitting and/or hose end must be replaced and then torqued to specification during installation. Refer to Section 2, *Hydraulic Hose and Fitting Torque Specifications*.

- 1 Remove the platform. See 1-1, *How to Remove the Platform*.
- 2 Remove the jib boom. See 2-1, *How to Remove the Jib Boom*.
- 3 Remove the wire harness cables from the bottom of the secondary boom. Secure the hydraulic hard lines to the boom.
- 4 Tag and disconnect the wire harness cables from the ground controls. Pull the cables to the mid pivot.

NOTICE Component damage hazard. Cables and hoses can be damaged if they are kinked or pinched.

Note: For ease of assembly, pay close attention to how the cables are routed when pulling the cables to the mid pivot.

PRIMARY BOOM COMPONENTS

- 5 Remove the harness clamps inside the mid pivot. Pull the wire harness cables through the mid pivot and lay them off to the side of the primary boom.

NOTICE Component damage hazard. Cables and hoses can be damaged if they are kinked or pinched.

- 6 Tag, disconnect and plug the hoses from the platform level master cylinder. Cap the fittings on the cylinder.

WARNING Bodily injury hazard. Spraying hydraulic oil can penetrate and burn skin. Loosen hydraulic connections very slowly to allow the oil pressure to dissipate gradually. Do not allow oil to squirt or spray.

- 7 Tag, disconnect and plug the hoses from the primary boom extension cylinder. Cap the fittings on the cylinder.

WARNING Bodily injury hazard. Spraying hydraulic oil can penetrate and burn skin. Loosen hydraulic connections very slowly to allow the oil pressure to dissipate gradually. Do not allow oil to squirt or spray.

- 8 Attach a lifting strap of suitable capacity from an overhead crane to the rod end of the primary lift cylinder. Support the cylinder. Do not apply any lifting pressure.

- 9 Remove the pin retaining fastener from the primary lift cylinder rod end pivot pin.

- 10 Using a soft metal drift, remove the primary lift cylinder rod end pivot pin.

WARNING Crushing hazard. The cylinder will fall if not properly supported when the pivot pin is removed.

- 11 Lower the cylinder onto the secondary boom.

- 12 Remove the pin retaining fastener from the platform level master cylinder rod end pivot pin.

- 13 Using a soft metal drift, remove the platform level master cylinder rod end pivot pin.

- 14 Attach a lifting strap of suitable capacity from an overhead crane to the primary boom. Support the boom. Do not apply any lifting pressure.

NOTICE Component damage hazard. The cable track can be damaged if not protected when lifting the boom.

- 15 Remove the pin retaining fasteners securing the primary boom pivot pin.

- 16 Using a soft metal drift, remove the primary boom pivot pin.

DANGER Crushing hazard. The primary boom could become unbalanced and fall if not properly supported when the pin is removed.

- 17 Release the latch at the turntable end of the machine.

- 18 Remove the primary boom from the machine.

DANGER Crushing hazard. The primary boom could become unbalanced and fall if not properly supported when removed from the machine.

PRIMARY BOOM COMPONENTS

How to Remove the Boom Extension

⚠WARNING This procedure in this section requires specific repair skills, lifting equipment and a suitable workshop. Attempting this procedure without these skills and tools could result in death or serious injury and significant component damage. Dealer service is required.

Follow the disassembly steps to the point required to complete the repair. Then re-assemble the secondary boom by following the disassembly steps in reverse order.

Note: When removing a hose assembly or fitting, the O-ring (if equipped) on the fitting and/or the hose end must be replaced. All connections must be torqued to specification during installation. Refer to Section 2, *Hydraulic Hose and Fitting Torque Specifications*.

- 1 Remove the platform. See 1-1, *How to Remove the Platform*.
 - 2 Remove the jib boom. See 2-1, *How to Remove the Jib Boom*.
 - 3 Remove the primary boom. See 3-2, *How to Remove the Boom*.
 - 4 Set the primary boom assembly on a suitable structure capable of supporting it.
 - 5 Place a block between the platform level slave cylinder and the extension boom.
 - 6 Remove the fasteners and hose clamp securing the platform level slave cylinder hoses to the extension boom.
 - 7 Remove the pin retaining fastener from the platform level slave cylinder barrel-end pivot pin.
 - 8 Using a soft metal drift, remove the platform level slave cylinder barrel-end pivot pin.
 - 9 Tag, disconnect and plug the hoses from the platform level slave cylinder. Cap the fittings on the cylinder.
 - 10 Remove the platform level slave cylinder from the boom.
 - 11 Remove the primary boom upper wear pad retaining fasteners. Remove the upper wear pads from the primary boom.
 - 12 Remove the primary boom side wear pad retaining fasteners. Remove the side wear pads and shims from the primary boom.
- Note: For ease of assembly, note the quantity and location of shims during disassembly.
- 13 Remove the primary boom lower wear pad retaining fasteners. Remove the lower wear pads from the primary boom.
 - 14 Remove the pin retaining fastener from the primary boom extension cylinder barrel-end pivot pin.
 - 15 Using a soft metal drift, remove the primary boom extension cylinder barrel-end pivot pin.
 - 16 Remove the boom extension from the primary boom.
 - 17 Remove the pin retaining fasteners from the primary boom extension cylinder rod-end pivot pins.
 - 18 Using a soft metal drift, remove the primary boom extension cylinder rod-end pivot pins.
 - 19 Remove the primary boom extension cylinder from the boom extension.

PRIMARY BOOM COMPONENTS

3-3**Primary Boom Lift Cylinder****How to Remove the Primary Boom Lift Cylinder**

The primary boom lift cylinder raises and lowers the primary boom. The primary boom lift cylinder is equipped with a counterbalance valve to prevent movement in the event of a hydraulic line failure.

Note: When removing a hose assembly or fitting, the O-ring (if equipped) on the fitting and/or the hose end must be replaced. All connections must be torqued to specification during installation. Refer to Section 2, *Hydraulic Hose and Fitting Torque Specifications*.

- 1 Tag, disconnect and plug the hydraulic hoses on the lift cylinder. Cap the fittings on the cylinder.

▲WARNING Bodily injury hazard. Spraying hydraulic oil can penetrate and burn skin. Loosen hydraulic connections very slowly to allow the oil pressure to dissipate gradually. Do not allow oil to squirt or spray.

- 2 Attach a lifting strap of suitable capacity from an overhead crane to the lift cylinder.
- 3 Remove the pin retaining fastener from the lift cylinder rod end pivot pin.
- 4 Using a soft metal drift, remove the lift cylinder rod end pivot pin.

▲WARNING Crushing hazard. The cylinder will fall if not properly supported when the pivot pin is removed.

- 5 Lower the cylinder onto the secondary boom.
- 6 Remove the pin retaining fastener from the lift cylinder barrel end pivot pin.
- 7 Using a soft metal drift, remove the lift cylinder barrel end pivot pin.

▲WARNING Crushing hazard. The cylinder could fall if not properly supported when the pivot pin is removed.

- 8 Carefully remove the cylinder from the machine.

▲WARNING Crushing hazard. The lift cylinder could become unbalanced and fall if not properly supported when removed from the machine.

PRIMARY BOOM COMPONENTS

3-4 Platform Leveling Cylinders

How to Remove the Master Cylinder

The master cylinder, located inside the mid pivot, acts as a pump for the slave cylinder, which is located at the platform end of the extension boom. The master cylinder operates in a closed-circuit hydraulic loop with the slave cylinder, keeping the platform level through the entire range of boom motion.

Note: When removing a hose assembly or fitting, the O-ring (if equipped) on the fitting and/or the hose end must be replaced. All connections must be torqued to specification during installation. Refer to Section 2, *Hydraulic Hose and Fitting Torque Specifications*.

- 1 Tag, disconnect and plug the master cylinder hydraulic hoses. Cap the fittings on the cylinder.

WARNING Bodily injury hazard. Spraying hydraulic oil can penetrate and burn skin. Loosen hydraulic connections very slowly to allow the oil pressure to dissipate gradually. Do not allow oil to squirt or spray.

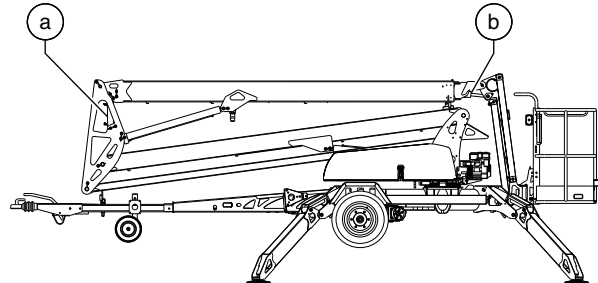

a platform level master cylinder
b platform level slave cylinder

- 2 Remove the pin retaining fastener from the master cylinder barrel end pivot pin.
- 3 Using a soft metal drift, remove the master cylinder barrel end pivot pin.
- 4 Attach a lifting strap from an overhead crane to the lug on the rod end of the master cylinder.
- 5 Remove the pin retaining fastener from the rod end pivot pin.
- 6 Using a soft metal drift, remove the master cylinder rod end pivot pin. Remove the master cylinder from the machine.

WARNING Crushing hazard. The master cylinder could become unbalanced and fall if not properly supported when removed from the machine

PRIMARY BOOM COMPONENTS

How to Remove the Slave Cylinder

The slave cylinder, via a closed-circuit hydraulic loop, works in tandem with the master cylinder to maintain the platform in a level condition through the entire range of boom motion. The slave cylinder, located at the platform end of the extension boom, is equipped with counterbalance valves to prevent movement in the event of a hydraulic line failure.

Before cylinder removal is considered to correct a malfunction, bleed the slave cylinder to be sure there is no air in the closed loop hydraulic circuit.

Note: When removing a hose assembly or fitting, the O-ring (if equipped) on the fitting and/or the hose end must be replaced. All connections must be torqued to specification during installation. Refer to Section 2, *Hydraulic Hose and Fitting Torque Specifications*.

- 1 Extend the boom approximately 12 inches / 30 cm.
- 2 Tag, disconnect and plug the slave cylinder hydraulic hoses from the tee fittings on the jib manifold, and connect them together using a connector. Cap the fittings on the manifold.

⚠ WARNING Bodily injury hazard. Spraying hydraulic oil can penetrate and burn skin. Loosen hydraulic connections very slowly to allow the oil pressure to dissipate gradually. Do not allow oil to squirt or spray.

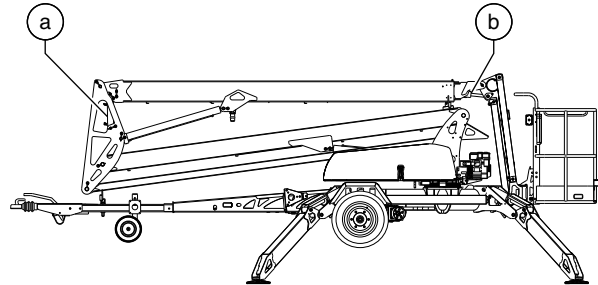

a platform level master cylinder
b platform level slave cylinder

- 3 Remove the pin retaining fastener from the slave cylinder rod end pivot pin. Do not remove the pin.
- 4 Remove the external retaining rings from the barrel end pivot pin.
- 5 Using a soft metal drift, remove the rod end pivot pin.
- 6 Carefully pull the cylinder out of the boom.

NOTICE Component damage hazard. Hoses can be damaged if they are kinked or pinched.

How to Bleed the Slave Cylinder

- 1 Raise the boom to a horizontal position.
- 2 Activate the platform level function in both up and down directions through two complete platform leveling cycles to remove any air that might be in the system.

The master cylinder acts as a pump for the slave cylinder. It is part of the closed loop hydraulic circuit that keeps the platform level through the entire range of boom motion. The master cylinder is located inside the mid pivot.

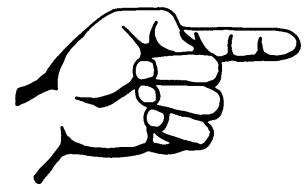

This page intentionally left blank.

Secondary Boom Components

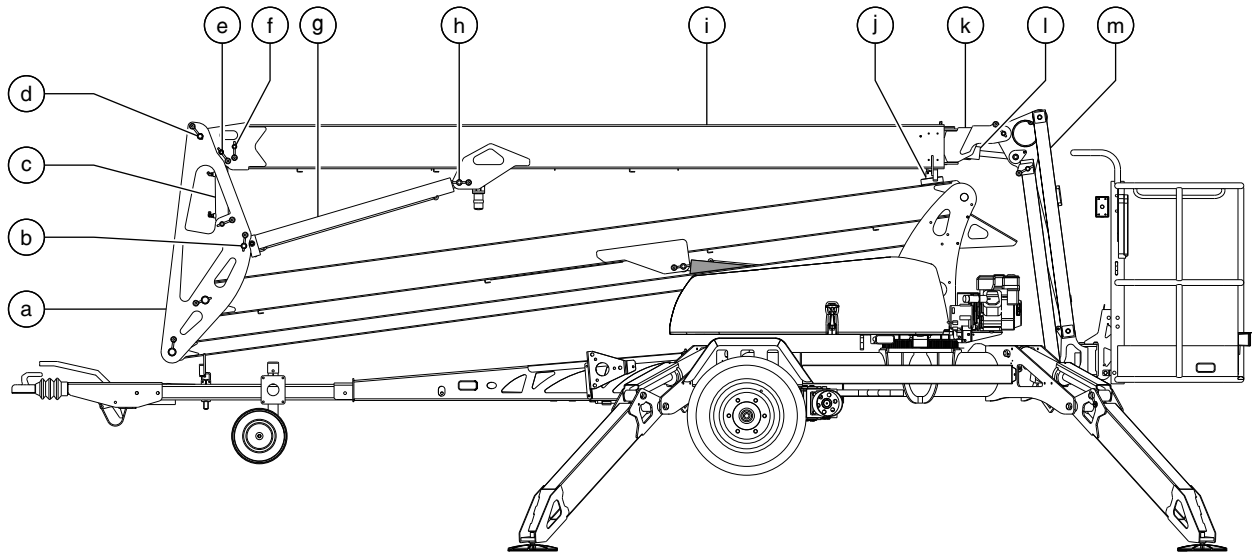

- | | | | |
|---|--|---|---|
| a | mid-pivot | m | jib boom |
| b | primary boom lift cylinder barrel-end pivot pin | n | secondary boom pivot pin |
| c | platform level master cylinder | o | secondary boom link pivot pin |
| d | primary boom pivot pin | p | secondary boom latch |
| e | platform level master cylinder rod-end pivot pin | q | secondary boom |
| f | extension cylinder barrel-end pivot pin | r | secondary boom link |
| g | primary boom lift cylinder | s | secondary lift cylinder rod-end pivot pin |
| h | primary boom lift cylinder rod-end pivot pin | t | secondary boom lift cylinder |
| i | primary boom | u | secondary lift cylinder barrel-end pivot pin
(located behind ground control box) |
| j | primary boom latch | v | turntable |
| k | extension boom | w | secondary boom pivot pin |
| l | platform level slave cylinder | | |

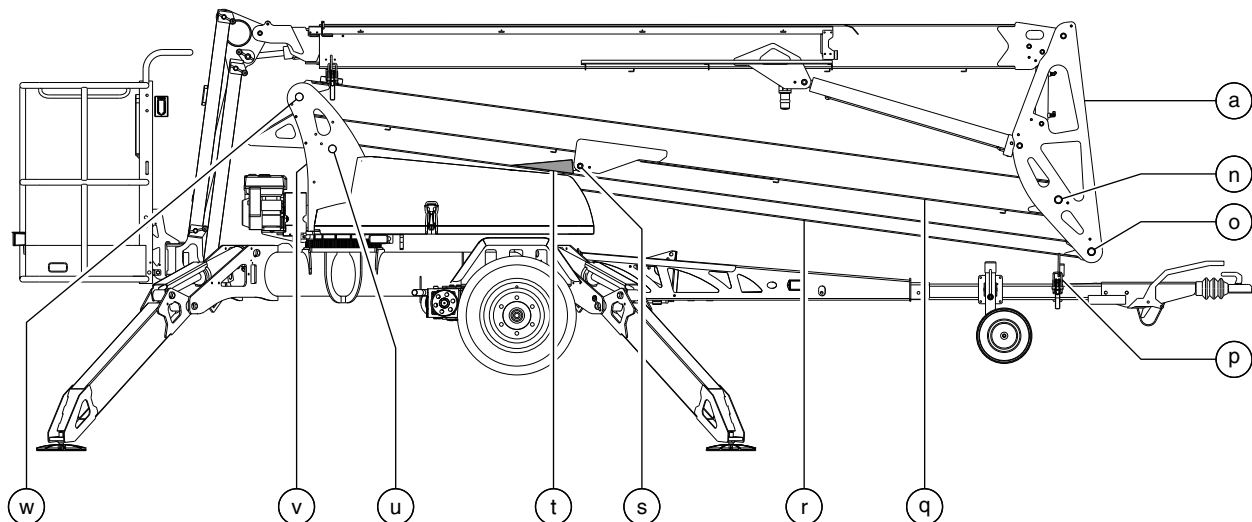

SECONDARY BOOM COMPONENTS

4-1 Secondary Boom

How to Remove the Secondary Boom

WARNING This procedure requires specific repair skills, lifting equipment and a suitable workshop. Attempting this procedure without these skills and tools could result in death or serious injury and significant component damage. Dealer service is required.

Follow the disassembly steps to the point required to complete the repair. Then re-assemble the secondary boom by following the disassembly steps in reverse order.

Note: When removing a hose assembly or fitting, the O-ring (if equipped) on the fitting and/or the hose end must be replaced. All connections must be torqued to specification during installation. Refer to Section 2, *Hydraulic Hose and Fitting Torque Specifications*.

- 1 Remove the platform. See 1-1, *How to Remove the Platform*.
- 2 Remove the jib boom. See 2-1, *How to Remove the Jib Boom*.
- 3 Remove the primary boom. See 3-2, *How to Remove the Primary Boom*.

Remove the mid-pivot

- 4 Attach a lifting strap of suitable capacity from an overhead crane to the rod end of the primary lift cylinder. Raise the cylinder to a horizontal position.

- 5 Remove the pin retaining fasteners securing the primary lift cylinder barrel end pivot pin.
- 6 Using a soft metal drift, remove the primary lift cylinder barrel end pivot pin. Remove the cylinder from the machine.

WARNING Crushing hazard. The cylinder could fall if not properly supported when the pivot pin is removed.

- 7 Attach a lifting strap of suitable capacity from an overhead crane to the mid-pivot. Support the mid pivot. Do not apply any lifting pressure.
- 8 Remove the pin retaining fasteners securing the secondary boom pivot pin at the mid-pivot.
- 9 Remove the pin retaining fasteners securing the secondary link pivot pin at the mid-pivot.
- 10 Tag, disconnect and plug the hydraulic hoses to the hydraulic hard lines at the mid-pivot end of the secondary boom. Cap the fittings.

WARNING Bodily injury hazard. Spraying hydraulic oil can penetrate and burn skin. Loosen hydraulic connections very slowly to allow the oil pressure to dissipate gradually. Do not allow oil to squirt or spray.

NOTICE Component damage hazard. Cables and hoses can be damaged if they are kinked or pinched.

- 11 Using a soft metal drift, remove the secondary boom pivot pin at the mid-pivot.

WARNING Crushing hazard. The mid-pivot could become unbalanced and fall if not properly supported when the pin is removed.

SECONDARY BOOM COMPONENTS

- 12 Using a soft metal drift, remove the secondary link pivot pin at the mid-pivot.

▲WARNING Crushing hazard. The secondary link could become unbalanced and fall if not properly supported when the pin is removed.

- 13 Remove the mid-pivot from the machine.

▲WARNING Crushing hazard. The mid-pivot could become unbalanced and fall if not properly supported when removed from the machine.

Remove the secondary boom

- 14 Attach a lifting strap of suitable capacity from an overhead crane to the secondary boom. Support the secondary boom. Do not apply any lifting pressure.

- 15 Remove the pin retaining fasteners securing the lift cylinder pivot pin to the secondary boom.

- 16 Place a wooden block between the secondary link and the secondary lift cylinder.

- 17 Using a soft metal drift, remove the lift cylinder pivot pin from the secondary boom.

▲WARNING Crushing hazard. The cylinder could fall if not properly supported when the pivot pin is removed.

- 18 Lower the cylinder onto the wooden block.

- 19 Raise the secondary boom to a horizontal position.

- 20 Tag, disconnect and plug the hydraulic hoses to the hydraulic hard lines at the turntable end of the secondary boom. Cap the fittings.

▲WARNING Bodily injury hazard. Spraying hydraulic oil can penetrate and burn skin. Loosen hydraulic connections very slowly to allow the oil pressure to dissipate gradually. Do not allow oil to squirt or spray.

NOTICE Component damage hazard. Cables and hoses can be damaged if they are kinked or pinched.

- 21 Remove the pin retaining fasteners securing the secondary boom pivot pin to the turntable.

- 22 Using a soft metal drift, remove the secondary boom pivot pin.

▲WARNING Crushing hazard. The secondary boom could become unbalanced and fall if not properly supported when the pin is removed.

- 23 Remove the secondary boom from the machine.

Remove the secondary link

- 24 Working at the ground controls, remove the power to platform wiring from the ground control box.

- 25 Remove the ground controls from the machine.

- 26 Rotate the rod end of the secondary boom lift cylinder approximately 90°.

- 27 Attach a lifting strap of suitable capacity from an overhead crane to the rod end of the lift cylinder. Raise the cylinder slightly, remove the block and lower the cylinder through the secondary link and onto the front bulkhead.

SECONDARY BOOM COMPONENTS

28 Remove the pin retaining fasteners securing the secondary link pivot pin to the turntable.

29 Using a soft metal drift, remove the secondary link pivot pin.

▲WARNING Crushing hazard. The secondary link could become unbalanced and fall if not properly supported when the pin is removed.

30 Release the latch at the tongue end of the machine.

31 Remove the secondary link from the machine.

▲WARNING Crushing hazard. The secondary link could become unbalanced and fall if not properly supported when removed from the machine.

32 Tag, disconnect and plug the hoses from the secondary lift cylinder. Cap the fittings on the cylinder.

33 Attach a lifting strap of suitable capacity from an overhead crane to the secondary lift cylinder. Raise the cylinder to a horizontal position.

34 Remove the pin retaining fasteners securing the secondary lift cylinder pivot pin to the mid-pivot.

35 Using a soft metal drift, remove the secondary lift cylinder pivot pin. Remove the cylinder from the machine.

▲WARNING Crushing hazard. The cylinder could fall if not properly supported when the pivot pin is removed.

4-2

Secondary Boom Lift Cylinder

The secondary boom lift cylinder raises and lowers the secondary boom. The secondary boom lift cylinder is equipped with a counterbalance valve to prevent movement in the event of a hydraulic line failure.

1 Release the boom latch at both the tongue end and turntable end of the boom.

2 Raise the secondary boom to a horizontal position.

3 Attach a lifting strap of suitable capacity from an overhead crane to the mid-pivot. Support the mid-pivot. Do not apply any lifting pressure.

4 Attach a lifting strap of suitable capacity from an overhead crane to the lift cylinder. Support the cylinder. Do not apply any lifting pressure.

5 Remove the pin retaining fasteners securing the lift cylinder rod end pivot pin.

6 Place a wooden block between the secondary link and the lift cylinder.

7 Using a soft metal drift, remove the lift cylinder pivot pin.

▲WARNING Crushing hazard. The cylinder could fall if not properly supported when the pivot pin is removed.

8 Lower the cylinder onto the wooden block.

9 Rotate the rod end of the secondary boom lift cylinder approximately 90°.

10 Raise the cylinder slightly, remove the block and lower the cylinder through the secondary link and onto the front bulkhead.

SECONDARY BOOM COMPONENTS

11 Tag, disconnect and plug the hydraulic hoses on the lift cylinder. Cap the fittings on the cylinder.

▲WARNING Bodily injury hazard. Spraying hydraulic oil can penetrate and burn skin. Loosen hydraulic connections very slowly to allow the oil pressure to dissipate gradually. Do not allow oil to squirt or spray.

Note: Place rags beneath the barrel end of the lift cylinder before loosening the hydraulic lines.

Note: It may be helpful to remove the turntable rotate motor.

12 Remove the pin retaining fasteners securing the lift cylinder barrel end pivot pin.

13 Using a soft metal drift, remove the lift cylinder barrel end pivot pin.

▲WARNING Crushing hazard. The cylinder could fall if not properly supported when the pivot pin is removed.

14 Carefully remove the cylinder from the machine.

▲WARNING Crushing hazard. The lift cylinder could become unbalanced and fall if not properly supported when removed from the machine.

Engine

5-1 Fuse Replacement

The electric engine starter circuit is protected by both a 5 amp and 50 amp fuse. If either fuse burns out, the electric starter will not operate. The engine can, however, still be manually started.

Additional engine information is available in the *Honda GX160 Engine Owner Manual* (Honda part number 31ZH7630) OR the *Honda Engines Shop Manual* (Honda part number 61ZH700).

Honda GX160 Owner's Manual

Genie part number 97228

Honda Engines Shop Manual

Genie part number 97229

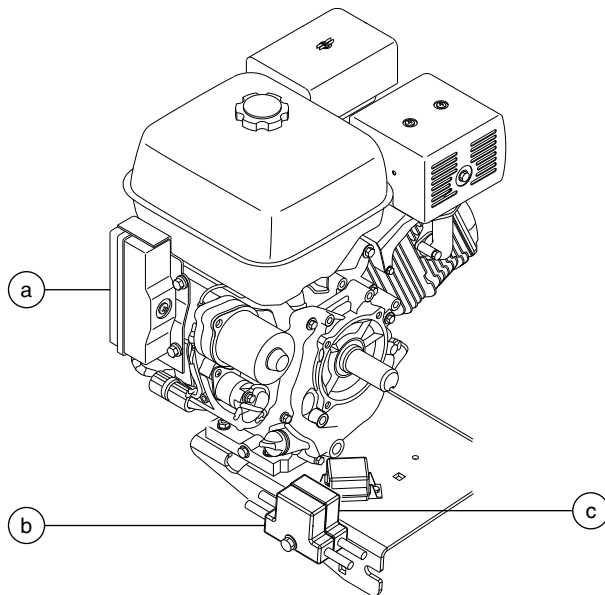

- a 5 amp fuse - starter circuit (inside cover)
- b 50 amp fuse - starter circuit
- c 50 amp fuse - alternator circuit

Ground Controls

6-1 Level Sensor

Each machine is equipped with two types of level sensors:

Tilt level sensor

One level sensor monitors the incline of the turntable after the outriggers are deployed and the machine is level. When this level sensor activates, an alarm will sound, making the operator aware of a potentially hazardous situation.

The tilt alarm sounds when the incline of the chassis exceeds 2.5° in any direction.

Outrigger auto level system

When deploying the outriggers using the autolevel function, outrigger level sensors are used to monitor the incline of the turntable and assist in leveling the machine.

In early production, two level sensors are components of the outrigger auto level circuit. Later in production, a single autolevel module was used.

How to Install and Calibrate the Tilt Level Level Sensor

⚠ DANGER Tip-over hazard. Failure to install or calibrate the level sensor as instructed could result in the machine tipping over causing death or serious injury. Do not install or calibrate the level sensor other than specified in this procedure.

- 1 Perform this procedure with the machine on a firm, level surface that is free of obstructions.
- 2 Turn the key switch to ground control and pull out the red Emergency Stop buttons to the on position at both the ground and platform controls.

- 3 Push and hold the yellow function enable button. Push and hold the auto level button.
- Result: The outriggers will lower and adjust to level the machine and raise the wheels off the ground. Use the bubble level located below the ground controls to confirm that the machine is level.
- 4 Turn the key switch to the off position.
- 5 Locate the tilt level sensor beneath the ground control panel. Refer to the following illustrations.

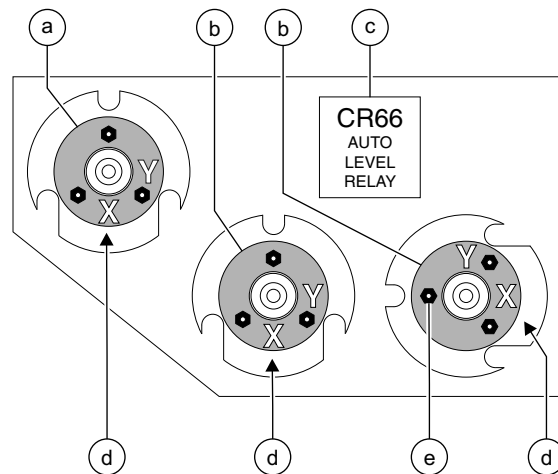

- a tilt level sensor
- b outrigger level sensor
- c autolevel relay (early production)
- d "X" indicator
- e adjusting fastener

If you are not installing a new level sensor, proceed to step 10.

Install the level sensor:

- 6 Tag and disconnect the wire harness from the tilt level sensor.
- 7 Remove the three level sensor retaining fasteners. Remove the level sensor from the machine.

GROUND CONTROLS

- 8 Install the new level sensor onto the machine with the "X" on the level sensor housing located as shown in the illustrations. Install and tighten the level sensor retaining fasteners.
- 9 Connect the wire harness to the level sensor.
- 10 Tighten the level sensor adjusting fasteners until the bubble in the top of the level sensor is centered in the circles.

Note: Be sure there are threads showing through the top of the adjusting fasteners.

- 11 Turn the key switch to ground control and pull out the red Emergency Stop buttons to the on position at both the ground and platform controls.
- 12 Raise the secondary boom approximately 12 inches / 30 cm.
 - ⦿ Result: The tilt sensor alarm should not sound.
- 13 Using a digital level, lower the tank side of the machine until the turntable is 2.4° out of level.
 - ⦿ Result: The tilt sensor alarm should not sound.
 - ✘ Result: The tilt alarm will sound at 180 beeps per minute. The level sensor is faulty and must be replaced. Repeat this procedure beginning with step 6.
- 14 Continue to lower the tank side of the machine until the turntable is 2.7° out of level.
 - ⦿ Result: The tilt alarm will sound at 180 beeps per minute.
 - ✘ Result: The tilt alarm does not sound. The level sensor is faulty and must be replaced. Repeat this procedure beginning with step 6.
- 15 Push and hold the yellow function enable button. Push and hold the auto level button.
 - ⦿ Result: The outriggers will lower and adjust to level the machine and raise the wheels off the ground. Use the bubble level located below the ground controls to confirm that the machine is level.
- 16 Using a digital level, lower the ground control side of the machine until the turntable is 2.4° out of level.
 - ⦿ Result: The tilt sensor alarm should not sound.
 - ✘ Result: The tilt alarm will sound at 180 beeps per minute. The level sensor is faulty and must be replaced. Repeat this procedure beginning with step 6.
- 17 Continue to lower the ground control side of the machine until the turntable is 2.7° out of level.
 - ⦿ Result: The tilt alarm will sound at 180 beeps per minute.
 - ✘ Result: The tilt alarm does not sound. The level sensor is faulty and must be replaced. Repeat this procedure beginning with step 6.
- 18 Push and hold the yellow function enable button. Push and hold the auto level button.
 - ⦿ Result: The outriggers will lower and adjust to level the machine and raise the wheels off the ground. Use the bubble level located below the ground controls to confirm that the machine is level.
- 19 Using a digital level, lower the platform end of the machine until the turntable is 2.4° out of level.
 - ⦿ Result: The tilt sensor alarm should not sound.
 - ✘ Result: The tilt alarm will sound at 180 beeps per minute. The level sensor is faulty and must be replaced. Repeat this procedure beginning with step 6.

GROUND CONTROLS

20 Continue to lower the platform end of the machine until the turntable is 2.7° out of level.

⦿ Result: The tilt alarm will sound at 180 beeps per minute.

✗ Result: The tilt alarm does not sound. The level sensor is faulty and must be replaced. Repeat this procedure beginning with step 6.

21 Push and hold the yellow function enable button. Push and hold the auto level button.

⦿ Result: The outriggers will lower and adjust to level the machine and raise the wheels off the ground. Use the bubble level located below the ground controls to confirm that the machine is level.

22 Using a digital level, lower the tongue end of the machine until the turntable is 2.4° out of level.

⦿ Result: The tilt sensor alarm should not sound.

✗ Result: The tilt alarm will sound at 180 beeps per minute. The level sensor is faulty and must be replaced. Repeat this procedure beginning with step 6.

23 Continue to lower the tongue end of the machine until the turntable is 2.7° out of level.

⦿ Result: The tilt alarm will sound at 180 beeps per minute.

✗ Result: The tilt alarm does not sound. The level sensor is faulty and must be replaced. Repeat this procedure beginning with step 6.

24 Return the outriggers to the stowed position.

How to Install and Calibrate the Outrigger Level Sensor

⚠ DANGER

Tip-over hazard. Failure to install or calibrate the level sensor as instructed could result in the machine tipping over causing death or serious injury. Do not install or calibrate the level sensor other than specified in this procedure.

- 1 Perform this procedure with the machine on a firm, level surface that is free of obstructions.
- 2 Turn the key switch to ground control and pull out the red Emergency Stop buttons to the on position at both the ground and platform controls.
- 3 Lower all four outriggers and raise the machine off the ground. Level the machine. Use the bubble level located below the ground controls to confirm that the machine is level.
- 4 Turn the key switch to the off position.

GROUNDCONTROLS

- 5 Locate the outrigger level sensors located below the ground control panel. Refer to the following illustrations.

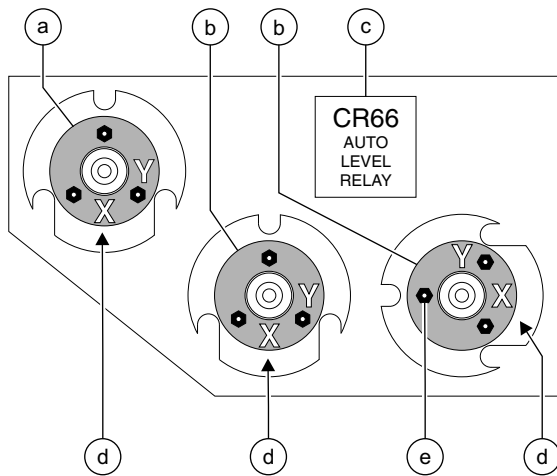

- a tilt level sensor
- b outrigger level sensor
- c autolevel relay (early production)
- d "X" indicator
- e adjusting fastener

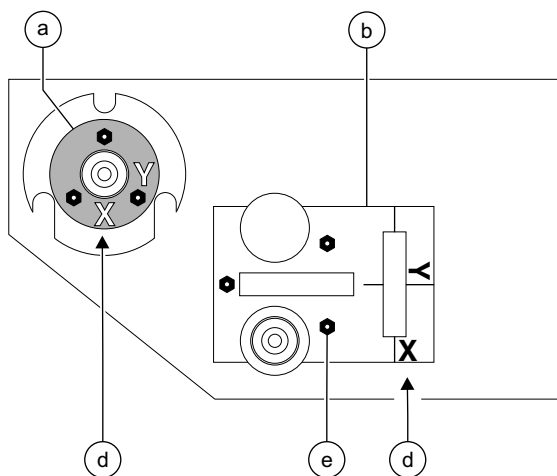

If you are not installing a new level sensor, proceed to step 10.

- 6 Tag and disconnect the wire harness from the outrigger level sensor.
- 7 Remove the three level sensor retaining fasteners. Remove the level sensor from the machine.
- 8 Install the new level sensor onto the machine with the "X" on the level sensor housing located as shown in the illustrations. Install and tighten the level sensor retaining fasteners.
- 9 Connect the wire harness to the level sensor.
- 10 Tighten the level sensor adjusting fasteners until the bubble in the top of the level sensor is centered in the circles.

Note: Be sure there are threads showing through the top of the adjusting fasteners.

- 11 Turn the key switch to ground control.
 - 12 Raise the outriggers until all of the outriggers are off the ground.
 - 13 Push and hold the yellow function enable button. Push and hold the auto level button.
- ⊙ **Result:** The outriggers will lower and adjust to level the machine and raise the wheels off the ground. Use the bubble level located below the ground controls to confirm that the machine is level.

Hydraulic Pump

7-1 Function Pump

The hydraulic pumps are attached to the motor which makes up the hydraulic power unit.

How to Test the Hydraulic Pump

Note: When removing a hose assembly or fitting, the O-ring (if equipped) on the fitting and/or the hose end must be replaced. All connections must be torqued to specification during installation. Refer to Section 2, *Hydraulic Hose and Fitting Torque Specifications*.

- 1 Tag, disconnect and plug the high pressure hydraulic hose from the hydraulic pump.

⚠ WARNING Bodily injury hazard. Spraying hydraulic oil can penetrate and burn skin. Loosen hydraulic connections very slowly to allow the oil pressure to dissipate gradually. Do not allow oil to squirt or spray.

- 2 Connect a 0 to 5000 psi / 0 to 350 bar pressure gauge to the high pressure port on the pump.
- 3 Turn the key switch to ground control and pull out the red Emergency Stop button to the on position at both the ground and platform controls.

- 4 Activate the platform up function from the ground controls.
 - ⊙ Result: If the pressure gauge reads 3200 psi / 221 bar, immediately stop. The pump is good.
 - ⊗ Result: If pressure fails to reach 3200 psi / 221 bar, the pump is bad and will need to be serviced or replaced.

NOTICE Component damage hazard. There is no relief valve in the hydraulic pump and the pump can be damaged if the pressure is allowed to exceed 3200 psi / 221 bar. When testing the pump, activate the pump in one second intervals until 3200 psi / 221 bar is confirmed. Do not over-pressurize the pump.

- 5 Remove the pressure gauge and reconnect the hydraulic hose. Torque to specification.

⚠ WARNING Bodily injury hazard. Spraying hydraulic oil can penetrate and burn skin. Loosen hydraulic connections very slowly to allow the oil pressure to dissipate gradually. Do not allow oil to squirt or spray.

HYDRAULIC PUMP

How to Remove the Hydraulic Pump

Note: When removing a hose assembly or fitting, the O-ring (if equipped) on the fitting and/or the hose end must be replaced. All connections must be torqued to specification during installation. Refer to Section 2, *Hydraulic Hose and Fitting Torque Specifications*.

- 1 Disconnect the battery pack from the machine.

⚠ WARNING Electrocutation hazard. Contact with electrically charged circuits could result in death or serious injury. Remove all rings, watches and other jewelry.

- 2 Tag and disconnect the hydraulic power unit cables at the motor controller.
- 3 Remove the hydraulic power unit retaining fasteners.
- 5 Tag, disconnect and plug the hydraulic hard line at the pump. Cap the fitting on the pump.
- 6 Tag, disconnect and plug the high pressure hose at the pump. Cap the fitting on the pump.

⚠ WARNING Bodily injury hazard. Spraying hydraulic oil can penetrate and burn skin. Loosen hydraulic connections very slowly to allow the oil pressure to dissipate gradually. Do not allow oil to squirt or spray.

- 7 Remove the pump mounting bolts. Carefully remove the pump.

⚠ DANGER Tip-over hazard. After replacing the hydraulic pump, it is critical to return the function speed settings to original factory specifications. Failure to restore the machine to original factory specifications could cause the machine to tip over resulting in death or serious injury.

Manifolds

8-1

Function Manifold Components

The function manifold is located under the turntable cover at the ground controls side of the machine.

Index No.	Description	Schematic Item	Function	Torque
—	Coil nut (items F, H, J, K, N, P and R)			4-5 ft-lbs / 7-9 Nm
1	Hand pump	A	Auxiliary down	25-27 ft-lbs / 34-36 Nm
2	Relief valve, 600 psi / 41 bar	B	Turntable rotate circuit	18-20 ft-lbs / 25-27 Nm
3	Differential sensing valve	C	Returns extra hydraulic fluid to tank when operating turntable rotate function	25-27 ft-lbs / 34-36 Nm
4	Shuttle valve, 2 position 3 way	D	Turntable rotate circuit	4-5 ft-lbs / 6 Nm
5	Orifice - plug, 0.040 inch / 1 mm	E	Restricts turntable rotate fluid flow	
—	Port plug			97-117 in-lbs / 11-13 Nm
6	Solenoid valve, 2 position 3 way with manual override	F	Secondary boom down	18-20 ft-lbs / 25-27 Nm
7	Diagnostic nipple	G	Testing	
8	Solenoid valve, 2 position 3 way with manual override	H	Primary boom down	18-20 ft-lbs / 25-27 Nm
9	Relief valve, 1600 psi / 110 bar	I	Primary boom circuit	18-20 ft-lbs / 25-27 Nm
10	Solenoid valve, 2 position 3 way with manual override	J	Primary boom up	18-20 ft-lbs / 25-27 Nm
11	Solenoid valve, 3 position 4 way with manual override	K	Boom extend/retract	18-20 ft-lbs / 25-27 Nm
12	Relief valve, 3000 psi / 207 bar	L	System relief	18-20 ft-lbs / 25-27 Nm
13	Counterbalance valve	M	Outrigger retract circuit	30-35 ft-lbs / 41-47 Nm
14	Solenoid valve, 3 position 4 way	N	Outrigger extend/retract	18-20 ft-lbs / 25-27 Nm
15	Check valve	O	Outrigger retract circuit	25-30 ft-lbs / 34-41 Nm
16	Solenoid valve, 2 position 3 way	P	Secondary boom up	18-20 ft-lbs / 25-27 Nm
17	Orifice - plug, 0.080 inch / 2 mm	Q	Restricts platform down fluid flow	
—	Port plug			97-117 in-lbs / 11-13 Nm
18	Solenoid valve, 3 position 4 way with manual override	R	Turntable rotate left/right	18-20 ft-lbs / 25-27 Nm

MANIFOLDS

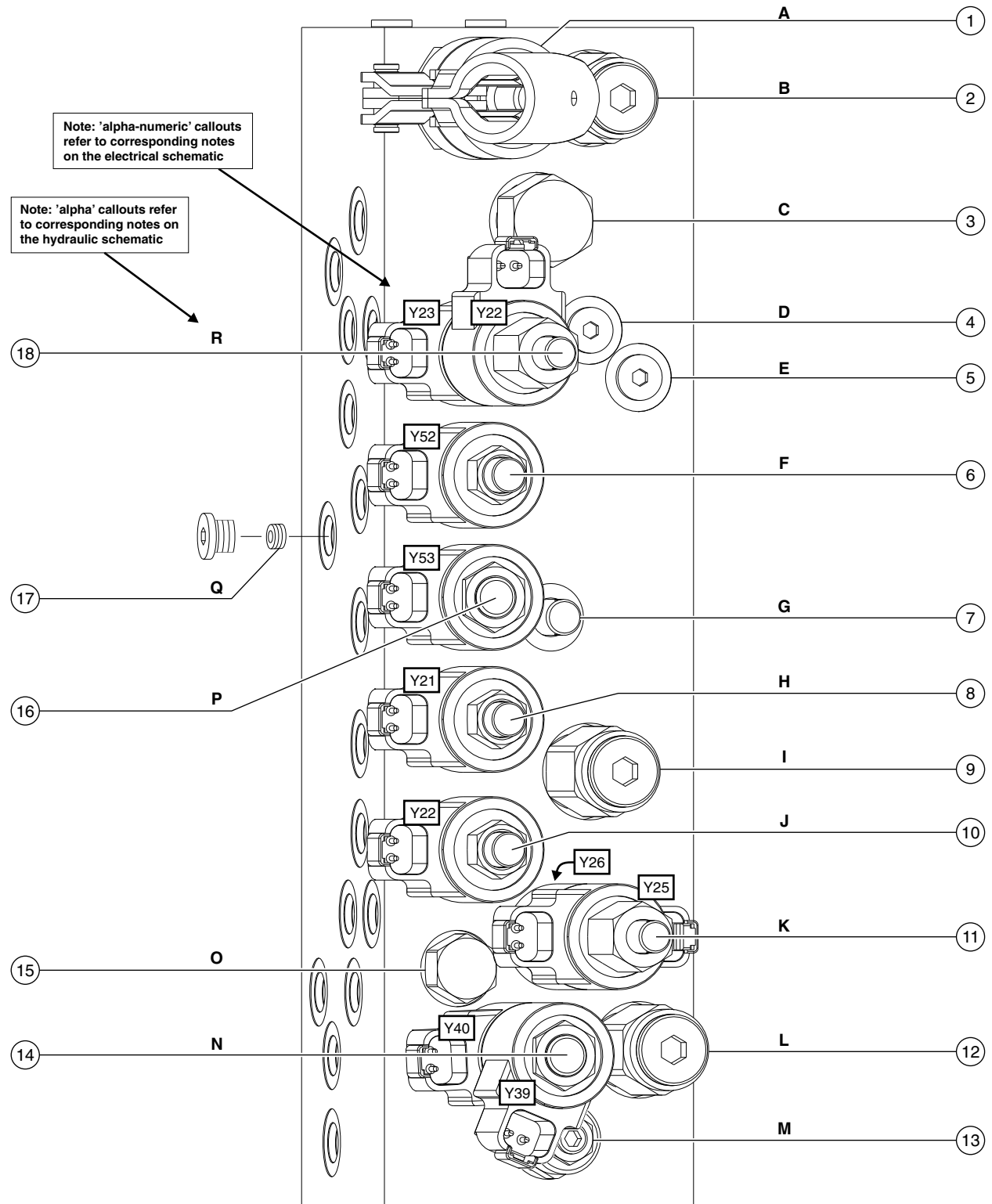

MANIFOLDS

8-2**Jib Manifold Components**

The jib manifold is located on the jib boom.

Index No.	Description	Schematic Item	Function	Torque
—	Coil nut (items AA, AB, AD and AE)			4-5 ft-lbs / 7-9 Nm
1	Solenoid valve, 2 position 3 way	AA	Jib boom up	18-20 ft-lbs / 25-27 Nm
2	Solenoid valve, 2 position 3 way	AB	Jib boom down	18-20 ft-lbs / 25-27 Nm
3	Relief valve, 3000 psi / 207 bar	AC	Platform level circuit	18-20 ft-lbs / 25-27 Nm
4	Solenoid valve, 3 position 4 way	AD	Platform rotate left/right	18-20 ft-lbs / 25-27 Nm
5	Solenoid valve, 3 position 4 way	AE	Platform up/down	18-20 ft-lbs / 25-27 Nm
6	Counterbalance valve	AF	Platform level circuit	25-30 ft-lbs / 34-41 Nm
7	Differential sensing valve	AG	Maintains fluid flow to jib boom, platform level and platform rotate functions	25-27 ft-lbs / 34-36 Nm
8	Orifice - plug, 0.055 inch / 1.4 mm	AH	Platform rotate circuit	
—	Port plug			97-117 in-lbs / 11-13 Nm
9	Orifice - plug, 0.055 inch / 1.4 mm	AI	Jib boom up circuit	
—	Port plug			97-117 in-lbs / 11-13 Nm
10	Orifice - plug, 0.040 inch / 1 mm	AJ	Jib boom down circuit	
—	Port plug			97-117 in-lbs / 11-13 Nm
11	Shuttle valve, 2 position 3 way	AK	Platform level circuit	4-5 ft-lbs / 6 Nm

MANIFOLDS

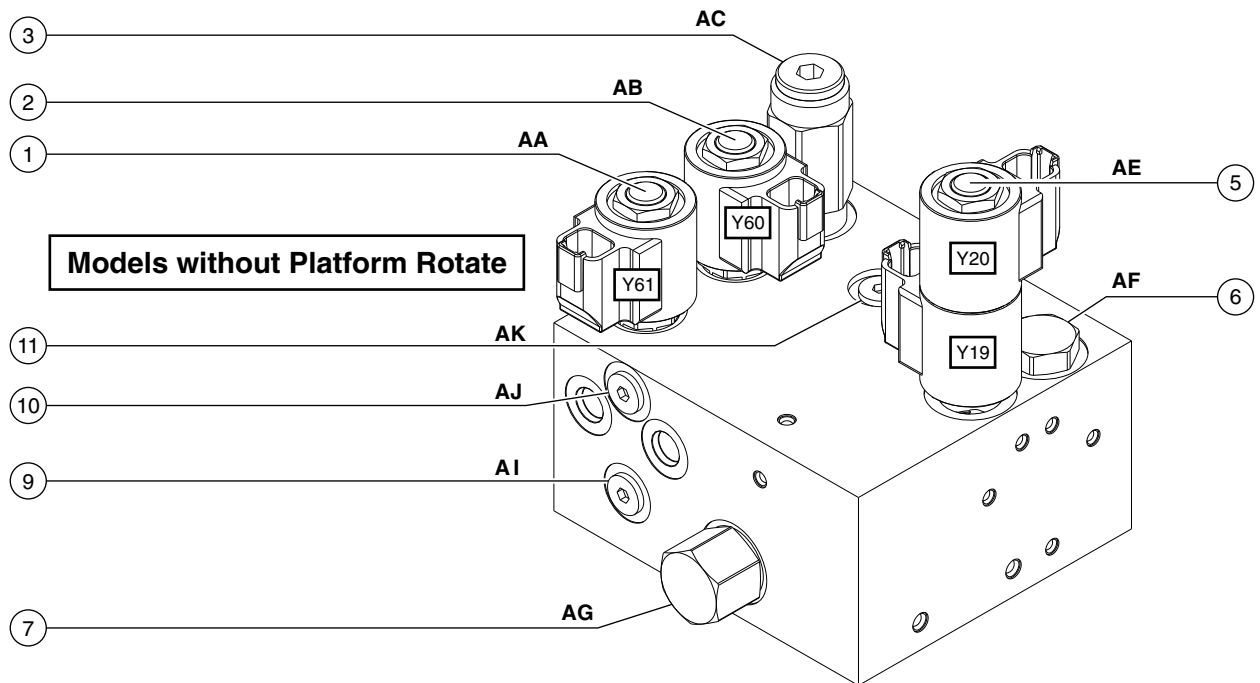
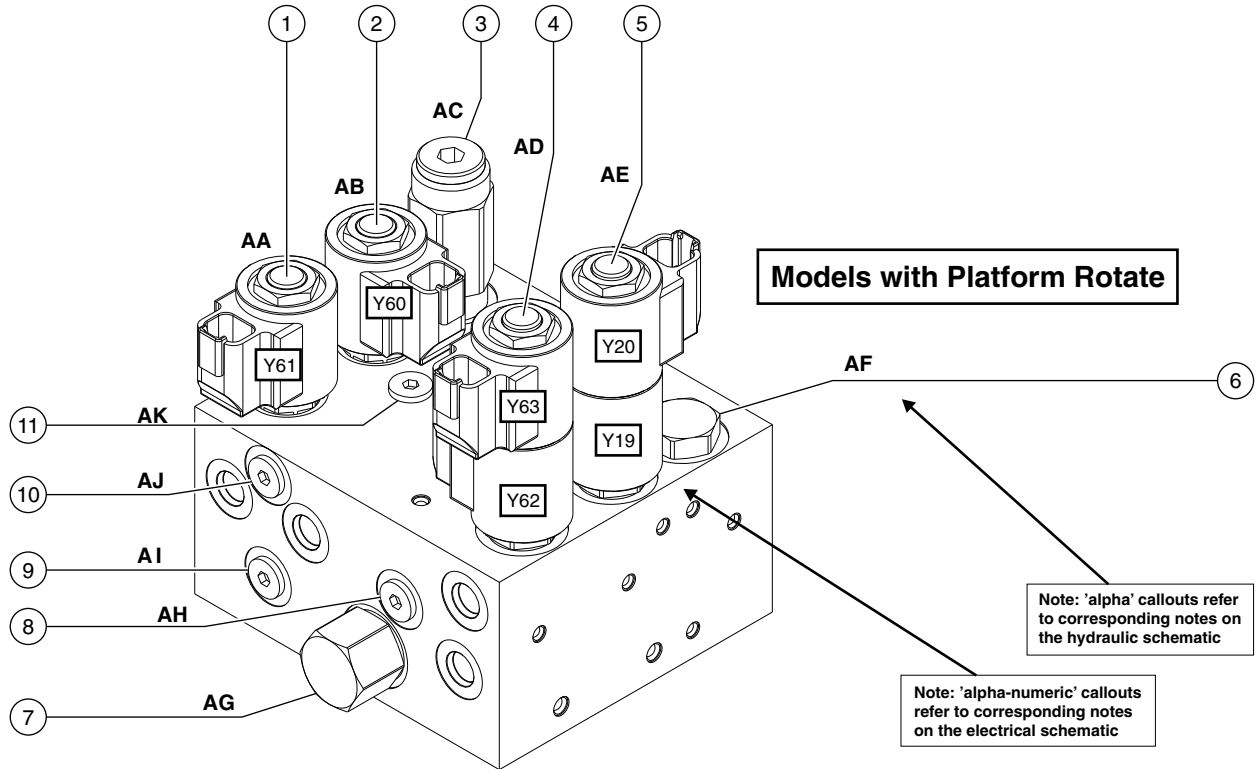

MANIFOLDS

8-3**Drive Manifold Components (if equipped)**

The drive manifold is located next to the function manifold.

Index No.	Description	Schematic		Torque
		Item	Function	
—	Coil nut (items BI, BK, BL, BN and BO)			4-5 ft-lbs / 7-9 Nm
1	Differential sensing valve	BA	Maintains traction equal to BJ	25-27 ft-lbs / 34-36 Nm
2	Orifice - plug, 0.090 inch / 2.3 mm	BB	Drive circuit	
3	Differential sensing valve	BC	Maintains torque while driving	25-27 ft-lbs / 34-36 Nm
4	Orifice - plug, 0.090 inch / 2.3 mm	BD	Pump 2 circuit	
—	Port plug			97-117 in-lbs / 11-13 Nm
5	Counterbalance valve	BE	Drive circuit, left side	30-35 ft-lbs / 41-47 Nm
6	Differential sensing valve	BF	Returns pump 2 hydraulic fluid to tank when not driving	25-27 ft-lbs / 34-36 Nm
7	Counterbalance valve	BG	Drive circuit, right side	25-30 ft-lbs / 34-41 Nm
8	Shuttle valve, 2 position 3 way	BH	Drive circuit	4-5 ft-lbs / 6 Nm
9	Solenoid valve, 2 position 2 way	BI	Brake release	18-20 ft-lbs / 25-27 Nm
10	Differential sensing valve	BJ	Maintains traction equal to BA	25-27 ft-lbs / 34-36 Nm
11	Proportional valve, 2 position 2 way ...	BK	Drive circuit, right side	18-20 ft-lbs / 25-27 Nm
12	Solenoid valve, 2 position 4 way	BL	Drive circuit, right side	18-20 ft-lbs / 25-27 Nm
13	Check valve, 10 psi / 0.7 bar	BM	Pump 2 circuit	18-20 ft-lbs / 25-27 Nm
14	Solenoid valve, 2 position 4 way	BN	Drive circuit, left side	18-20 ft-lbs / 25-27 Nm
15	Proportional valve, 2 position 2 way ...	BO	Drive circuit, left side	18-20 ft-lbs / 25-27 Nm

MANIFOLDS

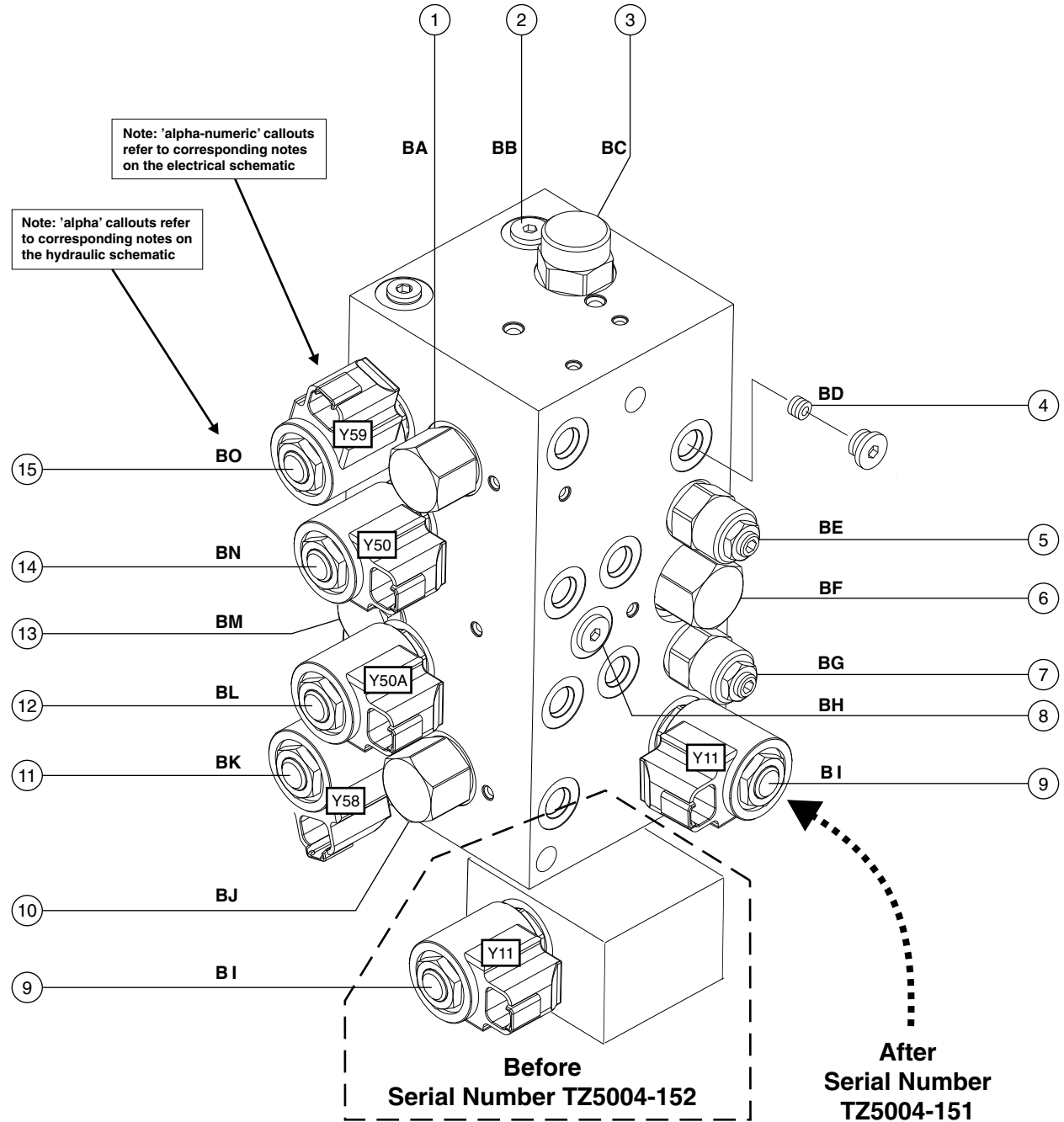

MANIFOLDS

8-4 Valve Adjustments - Function Manifold

How to Adjust the System Relief Valve

Note: Perform this procedure with the outriggers in the stowed position.

- 1 Connect a 0 to 5000 psi / 0 to 350 bar pressure gauge to the test port (item G) on the function manifold.
- 2 Turn the key switch to ground control and pull out the red Emergency Stop button to the on position at both the ground and platform controls.
- 3 Push and hold the yellow function enable down button. Observe the pressure reading on the pressure gauge. Refer to Section 2, *Specifications*.
- 4 Release the button. Use a wrench to hold the relief valve and remove the cap (item L).
- 5 Adjust the internal hex socket. Turn it clockwise to increase the pressure or counterclockwise to decrease the pressure. Install the relief valve cap.

⚠ DANGER Tip-over hazard. Do not adjust the relief valve higher than specified.

- 6 Repeat step 3 to confirm the relief valve pressure.

How to Adjust the Primary Boom Down Relief Valve

- 1 Connect a 0 to 5000 psi / 0 to 350 bar pressure gauge to the test port (item G) on the function manifold.
- 2 Turn the key switch to ground control and pull out the red Emergency Stop button to the on position at both the ground and platform controls.
- 3 Push and hold the yellow function enable button. Push and hold the auto level button.
- ⊙ Result: The outriggers will lower and adjust to level the machine and raise the wheels off the ground.
- 4 Push and hold the yellow function enable button. Push and hold the primary boom down button. Fully lower the primary boom and continue to hold the buttons while observing the pressure reading on the pressure gauge. Refer to Section 2, *Specifications*.
- 5 Release the buttons. Use a wrench to hold the relief valve and remove the cap (item I).
- 6 Adjust the internal hex socket. Turn it clockwise to increase the pressure or counterclockwise to decrease the pressure. Install the relief valve cap.

⚠ DANGER Tip-over hazard. Do not adjust the relief valve higher than specified.

- 7 Repeat step 4 to confirm the relief valve pressure.

MANIFOLDS

How to Adjust the Turntable Rotate Relief Valve

- 1 Connect a 0 to 5000 psi / 0 to 350 bar pressure gauge to the test port (item G) on the function manifold.
- 2 Turn the key switch to ground control and pull out the red Emergency Stop button to the on position at both the ground and platform controls.
- 3 Push and hold the yellow function enable button. Push and hold the auto level button.
- ⊙ Result: The outriggers will lower and adjust to level the machine and raise the wheels off the ground.
- 4 Raise the secondary boom approximately 12 inches / 30 cm.
- 5 Push and hold the blue function enable button. Push and hold the turntable rotate button. Fully rotate the turntable and continue to hold the buttons while observing the pressure reading on the pressure gauge. Refer to Section 2, *Specifications*.
- 6 Release the buttons. Use a wrench to hold the relief valve and remove the cap (item B).
- 7 Adjust the internal hex socket. Turn it clockwise to increase the pressure or counterclockwise to decrease the pressure. Install the relief valve cap.

⚠ DANGER Tip-over hazard. Do not adjust the relief valve higher than specified.

- 8 Push and hold the yellow function enable button. Push and hold the turntable rotate button and fully rotate the turntable in the opposite direction. Begin timing when the turntable begins to rotate.
- 9 Continue rotating the turntable and note the time when the machine stops rotating at 359°. Refer to Section 2, *Specifications*.

MANIFOLDS

8-5 Valve Coils

How to Test a Coil

A properly functioning coil provides an electromotive force which operates the solenoid valve. Critical to normal operation is continuity within the coil that provides this force field.

⚠ WARNING Electrocutation hazard. Contact with electrically charged circuits could result in death or serious injury. Remove all rings, watches and other jewelry.

- 1 Tag and disconnect the wire harness from the coil to be tested.
 - 2 Test the coil resistance.
- ⊕ Result: The resistance should be within specification, plus or minus 30%.
- ⊗ Result: If the resistance is not within specification, plus or minus 30%, replace the coil.

Valve Coil Resistance

Description	Specification
Solenoid valve, 2 position 3 way 20V DC with diode (schematic items F, G, I, AA and AB)	25 to 27Ω
Solenoid valve, 3 position 4 way 20V DC with diode (schematic items J, M, Q, AD and AE)	25 to 27Ω
Solenoid valve, 2 position 4 way 20V DC with diode (schematic item BI and BN)	25 to 27Ω
Solenoid valve, 2 position 2 way N.C. 20V DC with diode (schematic item BI)	25 to 27Ω
Proportional valve, 2 position 2 way N.C. 20V DC with diode (schematic item BK and BO)	25 to 27Ω
Solenoid valve, 2 position 2 way N.C. 24V DC with diode (schematic items CA, CB, CC and CD)	29 to 31W

MANIFOLDS

How to Test a Coil Diode

Genie incorporates spike-suppressing diodes in all of its coils. Properly functioning coil diodes protect the electrical circuit by suppressing voltage spikes. Voltage spikes naturally occur within a function circuit following the interruption of electrical current to a coil. Faulty diodes can fail to protect the electrical system, resulting in a tripped circuit breaker or component damage.

⚠ WARNING Electrocutation hazard. Contact with electrically charged circuits could result in death or serious injury. Remove all rings, watches and other jewelry.

- 1 Test the coil for resistance. See 4-3, *How to Test a Coil*.
- 2 Connect a 10Ω resistor to the negative terminal of a known good 9V DC battery. Connect the other end of the resistor to a terminal on the coil.

Note: The battery should read 9V DC or more when measured across the terminals.

Resistor, 10Ω

Genie part number

27287

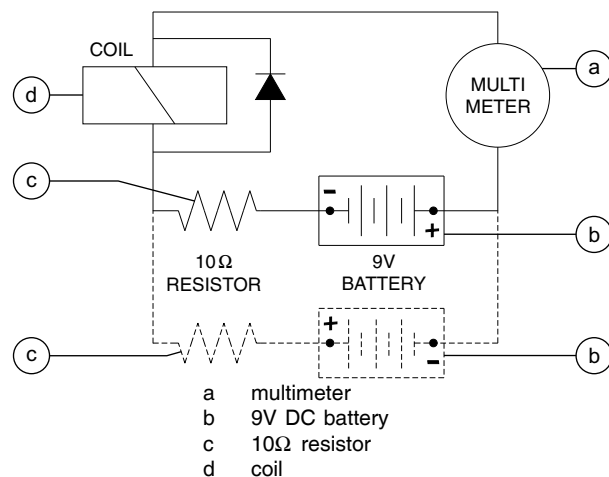

Note: Dotted lines in illustration indicate a reversed connection as specified in step 6

- 3 Set a multimeter to read DC amperage.

Note: The multimeter, when set to read DC amperage, should be capable of reading up to 800 mA.

- 4 Connect the negative lead to the other terminal on the coil.

Note: If testing a single-terminal coil, connect the negative lead to the internal metallic ring at either end of the coil.

- 5 Momentarily connect the positive lead from the multimeter to the positive terminal on the 9V battery. Note and record the current reading.
- 6 At the battery or coil terminals, reverse the connections. Note and record the current reading.

- ☉ Result: Both current readings are greater than 0 mA and are different by a minimum of 20%. The coil is good.
- ☒ Result: If one or both of the current readings are 0 mA, or if the two current readings do not differ by a minimum of 20%, the coil and/or its internal diode are faulty and the coil should be replaced.

Hydraulic Tank

9-1 Hydraulic Tank

The primary functions of the hydraulic tank are to cool and deaerate the hydraulic fluid during operation. It has an external return line filter.

How to Remove the Hydraulic Tank

NOTICE Component damage hazard. The work area and surfaces where this procedure will be performed must be clean and free of debris that could get into the hydraulic system.

Note: When removing a hose assembly or fitting, the O-ring (if equipped) on the fitting and/or the hose end must be replaced. All connections must be torqued to specification during installation. Refer to Section 2, *Hydraulic Hose and Fitting Torque Specifications*.

Note: Perform this procedure with the platform in the stowed position.

- 1 Disconnect the battery pack from the machine.

WARNING Electrocutation hazard. Contact with electrically charged circuits could result in death or serious injury. Remove all rings, watches and other jewelry.

- 2 Remove the drain plug from the hydraulic tank and allow all of the oil from the tank to drain into a suitable container. Refer to Section 2, *Specifications*.

WARNING Bodily injury hazard. Spraying hydraulic oil can penetrate and burn skin. Loosen hydraulic connections very slowly to allow the oil pressure to dissipate gradually. Do not allow oil to squirt or spray.

- 3 Tag and disconnect the return hard line from the filter head. Remove the hard line from the machine. Cap the fitting on the filter head.
- 4 Tag and disconnect the supply hard line from the pump. Cap the fitting on the pump.
- 5 Remove the hydraulic tank retaining fasteners and remove the hydraulic tank and supply hard line from the machine.

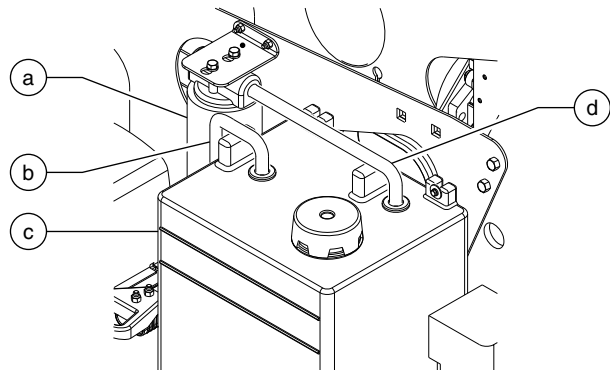

- a hydraulic filter
- b supply hard line (to pump)
- c hydraulic tank
- d return hard line (from filter)

Torque specifications

Hydraulic tank retaining fasteners, dry	35 in-lbs 4 Nm
Hydraulic tank retaining fasteners, lubricated	26 in-lbs 2.9 Nm

Axle Components

10-1 Axle

How to Remove the Axle

ANSI models:

- 1 Lower the outriggers and adjust to level the machine and raise the wheels off the ground.
- 2 Disconnect the secondary brake cables at the tension equalizer.
- 3 Pull the cables free of the trailer.
- 4 Tag, disconnect and plug the brake line from the back of the hub. Cap the fitting.
- 5 Clean up any brake fluid that may have spilled.
- 6 Repeat steps 4 through 5 for the other side.
- 7 Support and secure the axle assembly to an appropriate lifting device.
- 8 Remove the axle mounting fasteners and remove the axle from the machine.

WARNING Crushing hazard. The axle could become unbalanced and fall if not properly supported and secured when removed from the machine.

Note: When the axle is installed, the brakes should be bled. Refer to the appropriate brake manufacturer's manual that was shipped with your Genie TZ.

CE models:

- 1 Lower the outriggers and adjust to level the machine and raise the wheels off the ground.
- 2 Disconnect the secondary brake cables at the tension equalizer.
- 3 Support and secure the axle assembly to an appropriate lifting device.
- 4 Remove the axle mounting fasteners and remove the axle from the machine.

WARNING Crushing hazard. The axle could become unbalanced and fall if not properly supported and secured when removed from the machine.

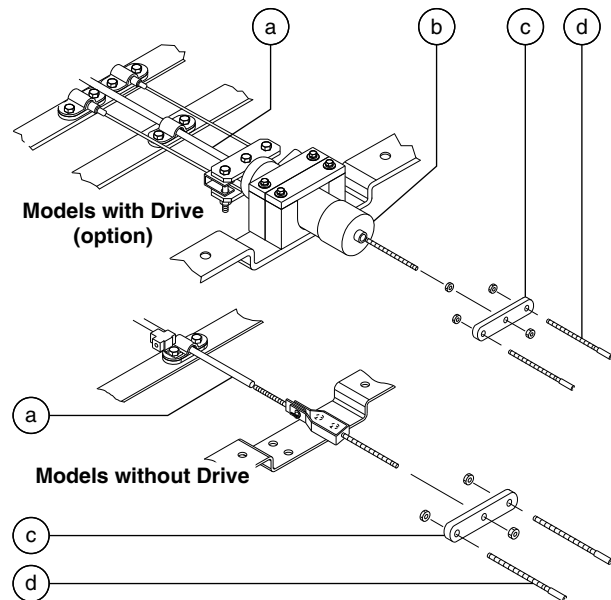

- a primary brake cable
- b parking brake cylinder (models with drive option)
- c tension equalizer
- d secondary brake cables

Trailer Components

11-1 Hydraulic and Mechanical Brakes

Hydraulic Brake System - Hydraulic Axle

Repair procedures and additional axle information is available in the *Dexter Axle Operation Maintenance Service Manual* (Dexter part number LIT-001-00).

Dexter Axle Operation Maintenance Service Manual
Genie part number 84376

Mechanical Brake System - Mechanical Axle

Repair procedures and additional axle information is available in the *KNOTT Axle Service Manual* (KNOTT part number P005).

KNOTT Axle Service Manual
Genie part number 84443

11-2 Parking Brake

How to Adjust the Parking Brake

ANSI models:

- 1 Adjust the brakes. Refer to the *Dexter Axle Operation Maintenance Service Manual* (Dexter part number LIT-001-00).

Dexter Axle Operation Maintenance Service Manual
Genie part number 84376

- 2 Chock the wheels.
 - 3 Release the parking brake.
 - 4 Loosen the set screw at the side of the parking brake handle.
 - 5 Adjust the handle just to the point where it is difficult to apply the parking brake, then rotate the top of the parking brake handle counterclockwise one full turn.
 - 6 Tighten the set screw. Do not over tighten.
 - 7 Engage the parking brake. Attempt to move the machine.
- ⊙ Result: The parking brake should prevent the machine from moving. If the parking brake does not prevent the machine from moving, repeat this procedure beginning with step 1.

CE models:

Required maintenance procedures and additional axle information is available in the *KNOTT Axle Service Manual* (KNOTT part number P005).

KNOTT Axle Service Manual
Genie part number 84443

Outriggers

12-1 Outrigger Components

How to Remove an Outrigger

Outriggers are essential to safe machine operation and machine stability. Operating a machine with a damaged or improperly operating outrigger will result in death or serious injury.

Note: Perform this procedure with the machine disconnected from the tow vehicle and the parking brake applied.

Note: Perform this procedure with the outriggers in the stowed position.

- 1 Attach a lifting strap of suitable capacity from an overhead crane to the pad end of the outrigger. Do not apply any lifting pressure.
- 2 Tag and disconnect the wire harness from the outrigger valve coil.
- 3 Tag, disconnect and plug the hydraulic hoses at the outrigger cylinder. Cap the fittings.
- 4 Remove the pin retaining fasteners from the outrigger pivot pin. Do not remove the pin.
- 5 Remove the pin retaining fasteners from the outrigger cylinder rod end pivot pin.
- 6 Attach a lifting strap of suitable capacity from an overhead crane to the rod end of the outrigger cylinder. Support the cylinder. Do not apply any lifting pressure.

- 7 Place a wooden block under the cylinder.
- 8 Lower the outrigger enough to remove the outrigger cylinder rod end pivot pin.
- 9 Using a soft metal drift, remove the outrigger cylinder rod end pivot pin.

▲WARNING Crushing hazard. The cylinder could fall if not properly supported when the pivot pin is removed from the machine.

- 10 Using a soft metal drift, remove the outrigger pivot pin. Remove the outrigger from the machine.

▲WARNING Crushing hazard. The outrigger will fall if not properly supported when the pivot pin is removed from the machine.

OUTRIGGERS

12-2 Outrigger Cylinder

How to Remove an Outrigger Cylinder

When removing a hose assembly or fitting, the O-ring on the fitting and/or hose end must be replaced and then torqued to specification during installation. Refer to Section 2, *Hydraulic Hose and Fitting Torque Specifications*.

- 1 Extend the outrigger until the pad just touches the ground. Do not rest the weight of the machine on the outrigger.
- 2 Remove the hose guard mounting fasteners from the rod end of the outrigger cylinder and remove the hose guard from the machine.
- 3 Remove the cover above the barrel end of the outrigger cylinder.
- 4 Tag and disconnect the wire harness from the outrigger cylinder valve coil.
- 5 Tag, disconnect and plug the hydraulic hoses from the outrigger cylinder. Cap the fittings on the cylinder.
- 6 Attach a lifting strap from an overhead crane to the lug on the rod end of the cylinder.
- 7 Remove the pin retaining fasteners from the outrigger cylinder rod-end pivot pin.
- 8 Using a soft metal drift, remove the outrigger cylinder rod-end pivot pin.
- 9 Raise the cylinder to a vertical position.
- 10 Remove the pin retaining fasteners from the outrigger cylinder barrel-end pivot pin.
- 11 Using a soft metal drift, remove the outrigger cylinder barrel-end pivot pin.

WARNING Crushing hazard. The outrigger cylinder could fall if not properly supported when the pivot pin is removed from the machine.

NOTICE Component damage hazard. The solenoid valve can be damaged. Use caution when removing the cylinder from the machine.

WARNING Bodily injury hazard. Spraying hydraulic oil can penetrate and burn skin. Loosen hydraulic connections very slowly to allow the oil pressure to dissipate gradually. Do not allow oil to squirt or spray.

Platform Overload Components

13-1 Platform Overload System

Calibrate the Platform Overload System (if equipped)

Note: Perform this procedure with the machine on a firm, level surface.

- 1 At the ground controls, extend the outriggers until the axle is off the ground and the machine is level.
- 2 Release the boom hold down latch and raise the platform approximately 2 feet / 60 cm. Level the platform.
- 3 Tag and disconnect the wire harness from the load sense limit switch.

Note: The load sense limit switch is located near the platform support.

- 4 Set a multi-meter to measure continuity. Connect the leads from the multi-meter to the black and red wires disconnected from the limit switch in step 3.
- 5 Determine the maximum platform capacity. Refer to the machine serial plate.
- 6 Using a suitable lifting device, place an appropriate test weight equal to that of the maximum platform capacity at the center of the platform floor.

Determine the limit switch trigger point:

- 7 Gently move the platform up and down by hand, so it bounces 1 to 2 inches / 2.5 to 5 cm.
- 8 Check the continuity between the black and red wires originating from the limit switch of the platform overload assembly.
 - ⊙ Result: **There is no continuity.** Slowly tighten the load spring adjustment nut by turning it clockwise just until the limit switch closes and shows continuity.
 - ⊙ Result: **There is continuity.** Slowly loosen the load spring adjustment nut by turning it counterclockwise just until the limit switch opens and shows no continuity.

Note: The platform will need to be continuously moved up and down while making adjustments.

Fine adjustment of the switch trigger point:

- 9 Continue moving the platform up and down and adjust the load spring adjustment nut clockwise or counterclockwise just until the limit switch is alternately opening and closing.

Note: When the limit switch is adjusted correctly, there will be continuity slightly longer than no continuity.

- 10 Remove the continuity tester from the limit switch wires. Securely install the wires onto the limit switch.

PLATFORM OVERLOAD COMPONENTS**Confirm the setting:**

- 11 Turn the key switch to platform control.
- 12 Lift the test weight off the platform floor using a suitable lifting device.
- 13 Place the test weight back onto the platform floor using a suitable lifting device.
- ⊙ Result: The platform overload indicator light should be off at both the ground and platform controls.
- 14 Add an additional 44 lbs / 20 kg of weight to overload the platform.
- ⊙ Result: The platform overload indicator light should be flashing at both the ground and platform controls.
- 15 Test all machine functions from the platform controls.
- ⊙ Result: All platform control functions should not operate.
- 16 Turn the key switch to ground control.
- 17 Test all machine functions from the ground controls.
- ⊙ Result: All ground control functions should not operate.

Drive Components

The TZ-50 drive option allows the operator to move the machine into another position without having to use a tow vehicle to do so. This option package includes drive controls, a brake cylinder, and a drive motor for each axle wheel.

When a drive function is activated at the drive control box, a signal is sent to one or more of the drive manifold valve coils, enabling the machine to move. The drive controls will function only when the machine is in the stowed position, the parking brake is set, and both wheel motors are in place against the axle tires.

To begin, manually move and lock the drive wheels in place against the axles tires. Then, by squeezing the joystick, to activate the drive function enable button, and moving the joystick in the desired direction, the parking brake will release via the parking brake cylinder located under the chassis, and both drive motors will activate which will in turn move the machine.

Returning the joystick to the neutral position will disable the drive and steer function, and set the parking brake.

14-1 Drive Motor

How to Remove a Drive Motor

When removing a hose assembly or fitting, the O-ring on the fitting and/or hose end must be replaced and then torqued to specification during installation. Refer to Section Two, *Hydraulic Hose and Fitting Torque Specifications*.

- 1 Remove the drive wheel retaining fasteners.
- 2 Remove the drive wheel.
- 3 Tag, disconnect and plug the hydraulic hoses from the drive motor. Cap the fittings.

⚠WARNING Bodily injury hazard. Spraying hydraulic oil can penetrate and burn skin. Loosen hydraulic connections very slowly to allow the oil pressure to dissipate gradually. Do not allow oil to squirt or spray.

- 4 Remove the drive motor mounting fasteners and remove the drive motor from the machine.

DRIVE COMPONENTS

14-2 Drive Control Box

Drive Control Box Circuit Board

Activating the joystick or a button on the box first sends a signal to the drive controls circuit board, then to the ground controls and finally the drive manifold valve coils which ultimately activates the drive function. The drive/steer functions can only be operated when the machine is in the stowed position and the parking brake set.

Over time, it may be necessary to recalibrate the drive controls. The drive controls printed circuit board can be adjusted for three different functions: steer left, steer right, and forward/reverse. For each function to operate correctly, two side-by-side potentiometers, Threshold and Hi-range, must be carefully adjusted. When accurately calibrated, the machine should steer and drive smoothly.

The drive control box consists of a printed circuit board, Emergency Stop button, joystick and, for ANSI models, buttons to operate the outriggers. All of the components are replaceable.

Keeping the drive controls clean and defect free is essential to safe machine operation. For further information or assistance, consult the Genie Industries Service Department.

How to Remove the Drive Circuit Board

- 1 Tag and disconnect the drive control wire harness from the ground controls.
- 2 Remove the drive control box from the control box mount. Turn the box over and remove the fasteners securing the bottom cover to the box. Remove the cover.
- 3 Locate the 6-pin Deutsch connector between the circuit board and the 14-wire main cable.

Note: The 6-pin connector and wiring originates from the circuit board nearest the B SIDE potentiometer.

Note: On the circuit board side, seven wires are installed into the 6-pin connector with two red wires installed into terminal 1.

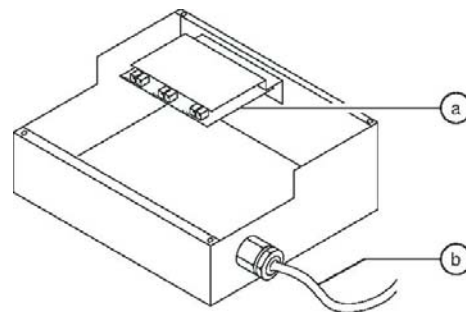

b 14-wire main cable

- 4 Tag and disconnect the circuit board from the 14-wire main cable.

NOTICE

Component damage hazard. Electrostatic discharge (ESD) can damage printed circuit board components. Use a grounded wrist strap at all times when handling printed circuit boards.

- 5 Tag and disconnect the joystick from the circuit board.
- 6 Remove the circuit board mounting fasteners and remove the circuit board from the box.

DRIVE COMPONENTS

How to Calibrate the Drive Circuit Board - to SN TZ5008-532

- 1 Remove the blue wire from terminal 1 of the motor controller U6.
- 2 Remove the drive control box from the control box mount. Turn the box over and remove the fasteners securing the bottom cover to the box. Remove the cover.
- 3 Turn the key switch to platform controls and pull out the Emergency Stop button to the on position at the ground, platform and drive controls.

Adjust both B SIDE potentiometers:

- 4 Without disconnecting the wire harness, connect the negative lead of the multimeter to the black wire of the 14-wire main cable.
- 5 Without disconnecting the wire harness, connect the positive lead of the multimeter to the orange wire of the 14-wire main cable.
- 6 Squeeze the joystick to activate the function enable switch SW5.
- ⊙ The voltage is 21.9 to 22.1V DC. Proceed to step 9.
- ✗ The voltage is less than 21.9 or greater than 22.1V DC. Proceed to step 7.
- 7 While activating the function enable switch, adjust the B SIDE HI RANGE potentiometer until the voltage is 22V DC. Release the joystick.
- 8 Repeat this procedure beginning with step 6.
- 9 Activate the function enable switch and move the joystick fully in the right direction.
- ⊙ The voltage is 3V DC. Proceed to step 12.
- ✗ The voltage is less than or greater than 3V DC. Proceed to step 10.

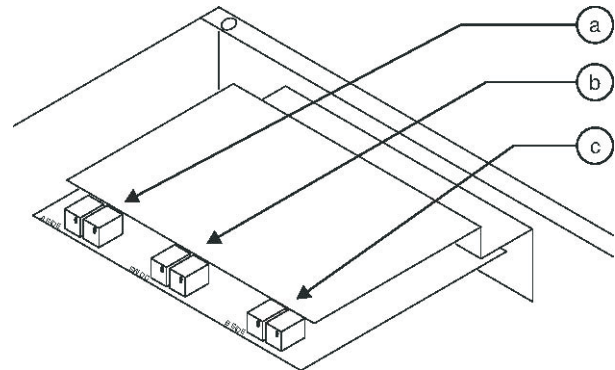

- a A side potentiometers
- b SW DC potentiometers
- c B side potentiometers

- 10 While activating the function enable switch and holding the joystick fully in the right direction, adjust the B SIDE THRESHOLD potentiometer until the voltage is 3V DC. Release the joystick.
- 11 Repeat this procedure beginning with step 9.
- 12 Disconnect the positive lead.

Adjust both A SIDE potentiometers:

- 13 Without disconnecting the wire harness, connect the positive lead of the multimeter to the orange/black wire of the 14-wire main cable.
- 14 Squeeze the joystick to activate the function enable switch SW5.
- ⊙ The voltage is 21.9 to 22.1V DC. Proceed to step 17.
- ✗ The voltage is less than 21.9 or greater than 22.1V DC. Proceed to step 15.
- 15 While activating the function enable switch, adjust the A SIDE HI RANGE potentiometer until the voltage is 22V DC. Release the joystick.

DRIVE COMPONENTS

- 16 Repeat this procedure beginning with step 14.
- 17 Activate the function enable switch and move the joystick fully in the left direction.
- ⦿ The voltage is 3V DC. Proceed to step 20.
 - ✖ The voltage is less than or greater than 3V DC. Proceed to step 18.
- 18 While activating the function enable switch and holding the joystick fully in the left direction, adjust the A SIDE THRESHOLD potentiometer until the voltage is 3V DC. Release the joystick.
- 19 Repeat this procedure beginning with step 17.
- 20 Disconnect the positive lead.
- Adjust both SW DC potentiometers:**
- 21 Without disconnecting the wire harness, connect the positive lead of the multimeter to the blue/black wire of the 14-wire main cable.
- 22 Activate the function enable switch and move the joystick fully in the forward direction.
- ⦿ The voltage is 4.9V DC. Proceed to step 25.
 - ✖ The voltage is less than or greater than 4.9V DC. Proceed to step 23.
- 23 While activating the function enable switch and holding the joystick fully in the forward direction, adjust the SW DC HI RANGE potentiometer until the voltage is 4.9V DC. Release the joystick.
- 24 Repeat this procedure beginning with step 22.
- 25 Activate the function enable switch and move the joystick fully in the reverse direction.
- ⦿ The voltage is 4.9V DC. Proceed to step 28.
 - ✖ The voltage is less than or greater than 4.9V DC. Proceed to step 26.
- 26 While activating the function enable switch and holding the joystick fully in the reverse direction, adjust the SW DC HI RANGE potentiometer until the voltage is 4.9V DC. Release the joystick.
- 27 Repeat this procedure beginning with step 25.
- 28 Confirm the forward and reverse settings. Repeat this procedure beginning with step 22. Adjusting the SW DC THRESHOLD potentiometer will determine where the voltage begins as you move the joystick in either forward or reverse.
- 29 Disconnect the positive and negative leads.
- 30 Push in the red Emergency Stop button to the off position at the ground, platform and drive controls.
- 31 Apply SentrySeal to the screws of the potentiometers which were adjusted.
- 32 Install the cover onto the box. Install and securely tighten the fasteners.
- 33 Install the drive control box onto the machine. Secure with the control box latch.
- 34 Securely connect the blue wire to terminal 1 of the motor controller.
- 35 Perform the function tests. Refer to the Operator's Manual on your machine.

Schematics



Observe and Obey:

- ☑ Troubleshooting and repair procedures shall be completed by a person trained and qualified on the repair of this machine.
- ☑ Immediately tag and remove from service a damaged or malfunctioning machine.
- ☑ Repair any machine damage or malfunction before operating the machine.

Before Troubleshooting:

- ☑ Read, understand and obey the safety rules and operating instructions in the appropriate Operator's Manual on your machine before attempting any maintenance or repair procedure.
- ☑ Be sure that all necessary tools and test equipment are available and ready for use.

About This Section

There are two groups of schematics in this section.

Electrical Schematics

⚠WARNING Electrocution/burn hazard. Contact with electrically charged circuits could result in death or serious injury. Remove all rings, watches and other jewelry.

Hydraulic Schematics

⚠WARNING Bodily injury hazard. Spraying hydraulic oil can penetrate and burn skin. Loosen hydraulic connections very slowly to allow the oil pressure to dissipate gradually. Do not allow oil to squirt or spray.

General Repair Process

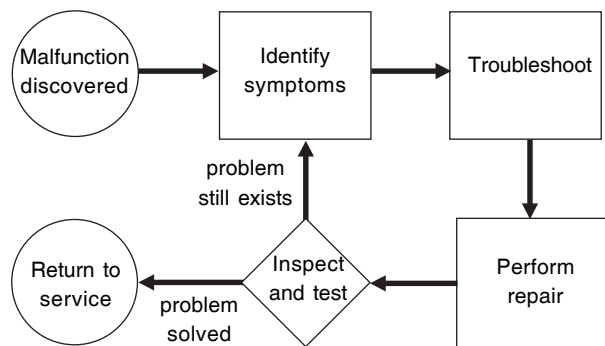

Electrical Abbreviations Legend

Item	Description
B	Battery
B5	Battery
BN	Button
BN2	Engine start
BN3	Choke
BN36	Jib boom up/down
BN49	Outrigger auto level
BN50	Left rear outrigger
BN51	Right rear outrigger
BN52	Left front outrigger
BN53	Right front outrigger
BN54	Primary boom up/down
BN55	Secondary boom up/down
BN56	Boom extend/retract
BN57	Turntable rotate
BN58	Platform level up/down
BN59	Function enable (boom down, boom retract, rotate left, outrigger extend)
BN60	Function enable (boom up, boom extend, rotate right, outrigger retract)
BN61	Function enable (boom down, boom retract, turntable/platform rotate left)
BN62	Function enable (boom up, boom extend, turntable/platform rotate right)
BN63	Primary boom up/down
BN64	Secondary boom up/down
BN65	Boom extend/retract
BN66	Turntable rotate
BN67	Platform level up/down
BN68	Engine start
BN90	Choke
BN93	Platform rotate

Item	Description
BN	Button
BN94	Function enable (boom down, boom retract, rotate left, outrigger extend)
BN95	Function enable (boom up, boom extend, rotate right, outrigger retract)
BN96	Autolevel
BN97	Jib boom up/down
BN98	Platform rotate
C	Capacitor
C4	Zener diode, 5.1V DC
C4A	Zener diode, 3.3V DC
C4B	Zener diode, 5.1V DC
C5	4700uF
CB	Circuit Breaker
CB1	Engine, 15A
CB2	Controls, 15A
CR	Control Relay
CR1	Engine start
CR8	Ignition
CR9	Jib boom up/down
CR15	Choke
CR28	Power supply
CR61	Auto level system
CR64	Fault ground
CR65	Motor controller cutout
CR66	Level sensor (auto level)
CR67	Primary boom
CR68	Secondary boom
CR69	Boom extend/retract
CR70	Turntable rotate

Electrical Abbreviations Legend

Item	Description
CR	Control Relay
CR71	Platform level
CR72	Outrigger
CR73	Function enable (ground controls)
CR74	Function enable (platform controls)
CR75	Level sensor
CR76	Limit switch fault
CR77	Down enable
CR78	Lift cut-out
CR86	Sequencing
CR87	Platform rotate
D1	Alternator
F	Fuse
F6	Function, 275A
F9	Alternator, 50A
F9A	Engine starter, 50A
FB1	Flashing Beacons (option)
GND	Ground
G	Gauge
G6	Hour meter
G7	Battery charge indicator (option)
H	Horn or Alarm
H1	Horn
H5	Multifunction alarm
JC5	Joystick
KS1	Keyswitch

Item	Description
L	Light or LED
L4	Load sense at ground (load sense option)
L4A	Load sense at platform (load sense option)
L12	Left front outrigger
L13	Right front outrigger
L14	Left rear outrigger
L15	Right rear outrigger
L33	Right rear tail light
L34	Left rear tail light
L35	Right side marker
L36	Left side marker
L58	License plate light
LS	Limit Switch
LS12	Left front outrigger
LS13	Right front outrigger
LS14	Left rear outrigger
LS15	Right rear outrigger
LS18	Boom down
LS18A	Boom down
LS19	Load sense
M	Motor
M3	Engine starter
M5	Hydraulic power unit
N.C.	Normally closed
NCHO	Normally closed, held open
N.O.	Normally Open
NOHC	Normally open, held closed
P	Power switch
P1	Emergency Stop button at ground controls
P2	Emergency Stop button at plat. controls
P3	Emergency Stop button at drive controls
Q7	Choke Solenoid

Electrical Abbreviations Legend

Item	Description
R	Resistor
R14	Function speed, 0-10K ohms
R22	1000 ohm
R22B	5600 ohm
S	Sensor
S7	Level sensor
S9	Level sensor, front/rear axis (auto level)
S10	Level sensor, left/right axis (auto level)
U	Electronic Component
U6	Motor controller
U9	Battery charger
U16	Time delay
U24	Drive controls printed circuit board
U26	Ignition module
Y	Valve Coil
Y11	Brake release
Y19	Platform down
Y20	Platform up
Y21	Primary down
Y22	Primary up
Y23	Turntable rotate left
Y24	Turntable rotate right
Y25	Boom retract
Y26	Boom extend
Y33	Left rear outrigger
Y34	Right rear outrigger
Y35	Left front outrigger
Y36	Right front outrigger
Y39	Outrigger retract
Y40	Outrigger extend
Y50	Drive forward/reverse left
Y50A	Drive forward/reverse right
Y52	Secondary down
Y53	Secondary up
Y58	Proportional drive right
Y59	Proportional drive left
Y60	Jib boom retract
Y61	Jib boom extend
Y62	Platform rotate left
Y63	Platform rotate right

Wire Color Legend	
Item	Description
BL	Blue
BK	Black
GN	Green
OR	Orange
RD	Red
WH	White
BL/BK	Blue / Black
BL/WH	Blue / White
BK/RD	Black / Red
BK/WH	Black / White
GN/BK	Green / Black
GN/WH	Green / White
OR/BK	Orange / Black
OR/RD	Orange / Red
OR/WH	Orange / White
RD/BK	Red / Black
RD/WH	Red / White
WH/BK	White / Black
WH/RD	White / Red

Limit Switch Legend

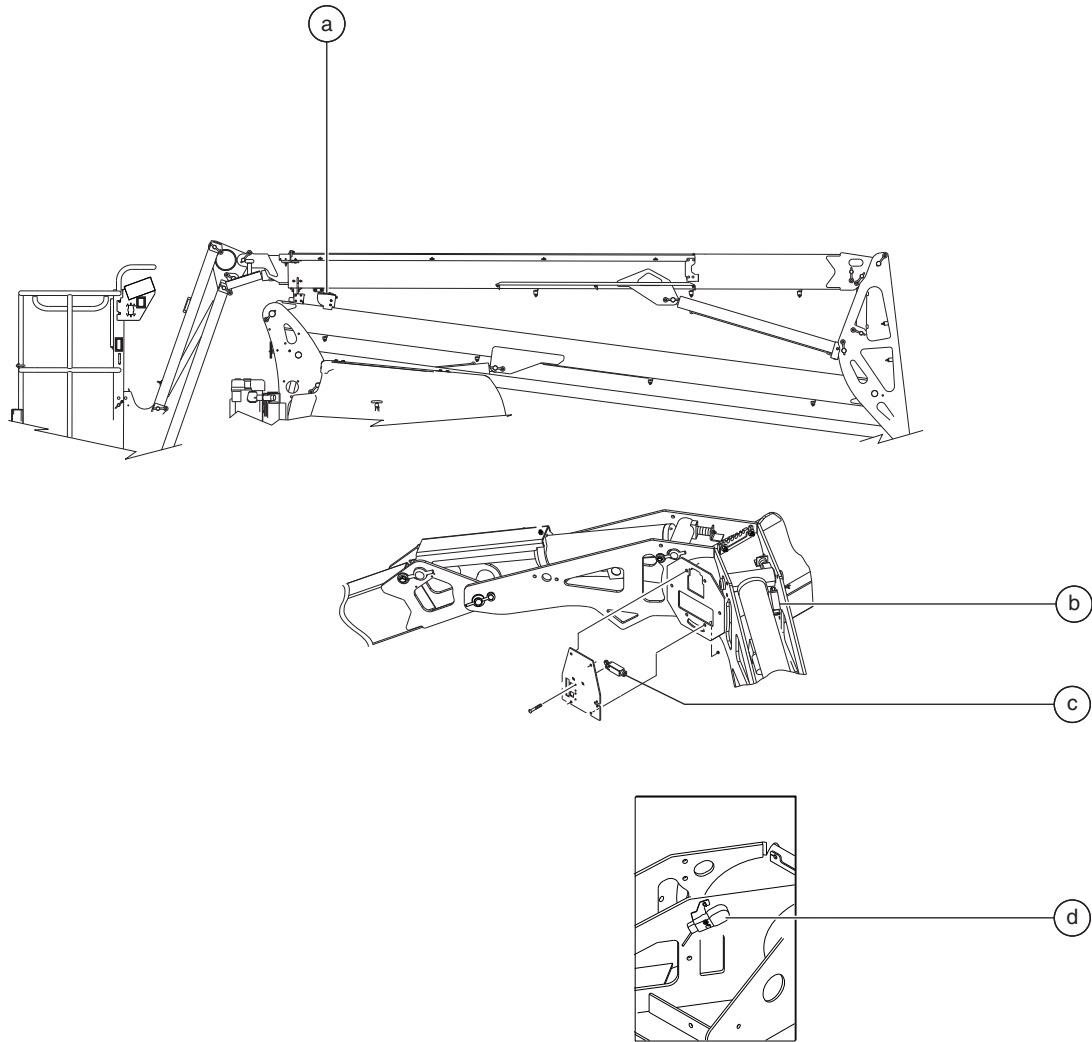

Item	Description	Schematic
a	Boom limit switches	LS18 / LS18A
b	Outrigger limit switch	LS12/LS13/LS14/LS15 to TZ5006-159
c	Boom limit switch	LS18 to TZ5006-159
d	Outrigger limit switch	LS12/LS13/LS14/LS15 from TZ5006-160

Electrical Symbols Legend

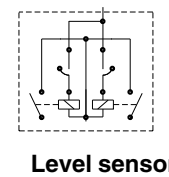
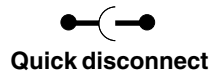
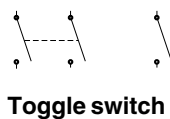
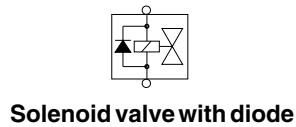
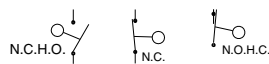
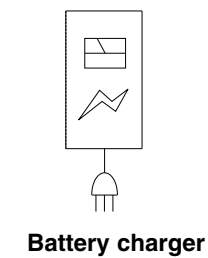
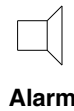
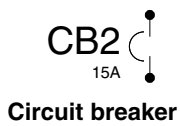
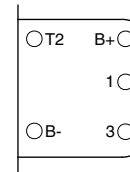
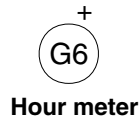
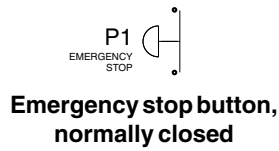
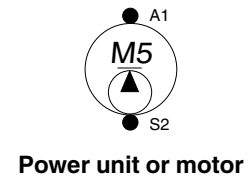
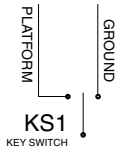
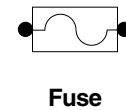
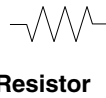
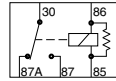
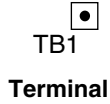

Abbreviation Legend

Hydraulic Schematics

Item	Description	Item	Description
A	Auxiliary pump	BA	Pilot operated directional valve - left
B	Relief valve - turntable rotate	BB	Orifice - drive speed
C	Pilot operated relief valve	BC	Pilot operated pressure compensator
D	Shuttle valve - turntable rotate	BD	Orifice - drive speed
E	Orifice - turntable speed	BE	Counterbalance valve
F	Secondary boom down (with override)	BF	Pilot operated pressure compensator
G	Primary boom down (with override)	BG	Counterbalance valve
H	Relief valve - primary boom	BH	Shuttle valve
I	Primary boom up (with override)	BI	Brake Dump
J	Boom extend/retract (with override)	BJ	Pilot operated directional valve - right
K	System relief	BK	Proportional valve - right
L	Outrigger counterbalance	BL	Drive forward/reverse - right
M	Outrigger extend/retract	BM	Check valve - drive circuit
N	Check valve - outrigger circuit	BN	Drive forward/reverse - left
O	Secondary boom up	BO	Proportional valve - left
P	Orifice - primary/secondary boom down speed	CA	Outrigger - left rear
Q	Turntable rotate left/right (with override)	CB	Outrigger - right rear
AA	Jib boom extend	CC	Outrigger - left front
AB	Jib boom retract	CD	Outrigger - right front
AC	Relief valve - platform level circuit	CE	Parking brake release (drive option)
AD	Platform rotate left/right (option)		
AE	Platform level up/down		
AF	Platform level counterbalance		
AG	Pilot operated relief valve		
AH	Orifice - platform rotate speed		
AI	Orifice - jib boom up speed		
AJ	Orifice - jib boom down and platform level speed		
AK	Shuttle valve - platform level circuit		

Hydraulic Symbols Legend



Filter



Shuttle valve



Check valve



Orifice with size



Check valve,
pilot to open



Motor



Fixed
displacement
pump



Variable speed motor

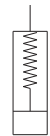

Brake release

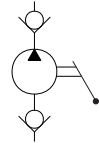

Fixed
displacement
hand pump

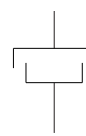

Brake

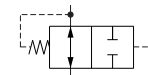

Pilot operated
2 position 2 way
directional valve
normally open

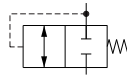

Pilot operated
2 position 2 way
pressure compensator
normally closed

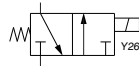

Solenoid operated
2 position 3 way
directional valve

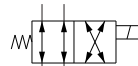

Solenoid operated
2 position 4 way
directional valve

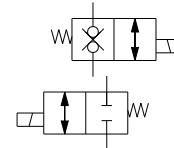

Solenoid operated
2 position 2 way
directional valve
normally closed

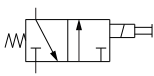

Solenoid operated
2 position 3 way
directional valve with
manual override

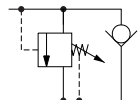

Adjustable relief valve

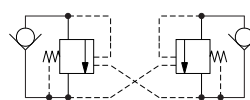

Counterbalance
valve

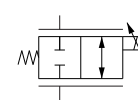

Solenoid operated
2 position 2 way
proportional valve
normally closed



Double acting cylinder

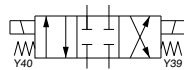

Solenoid operated
3 position 4 way
directional valve

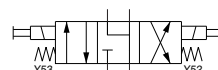

Solenoid operated
3 position 4 way
directional valve with
manual override

Honda GX160 Engine Wiring Diagram

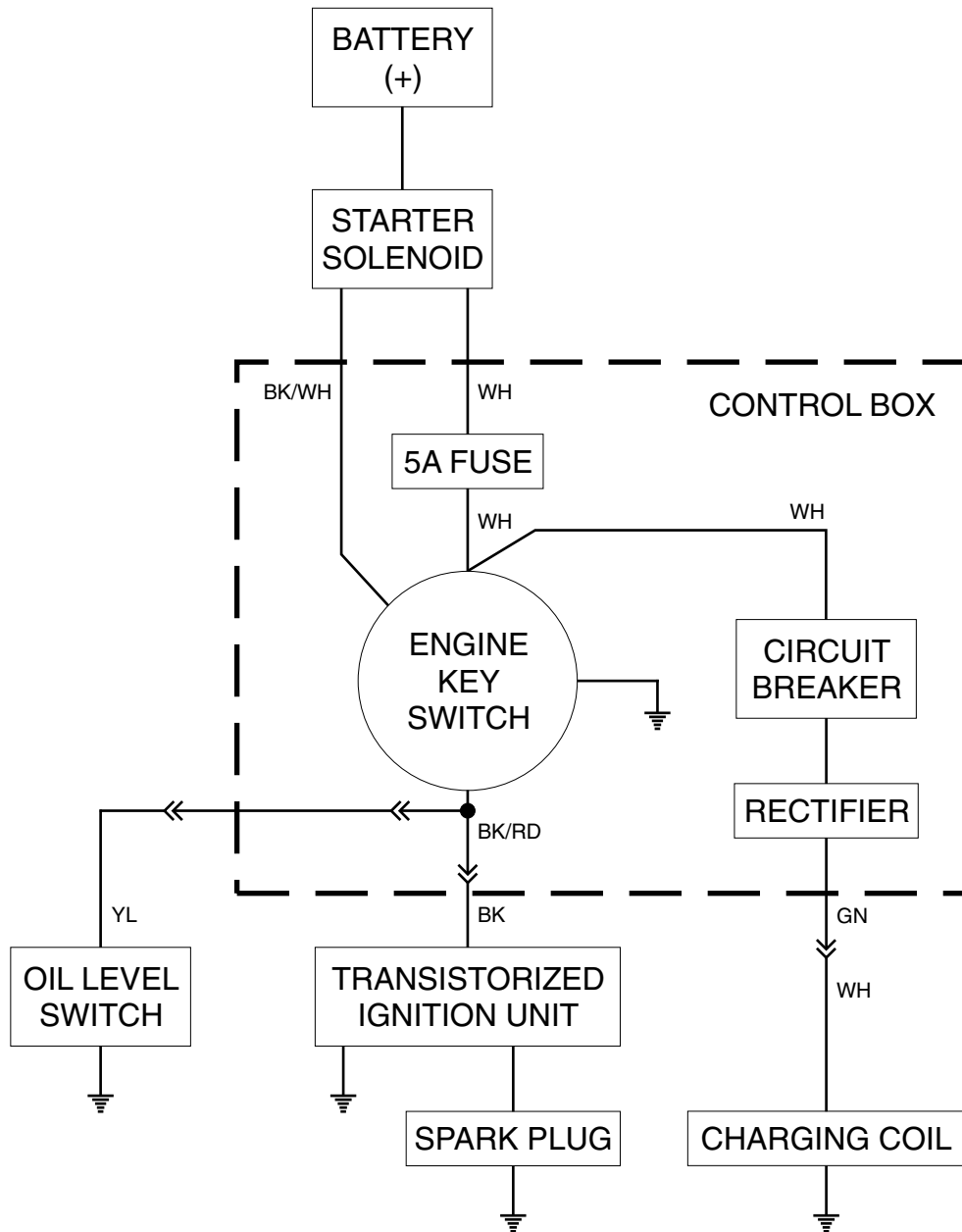

Trailer Lighting Wiring Diagram - ANSI / CSA

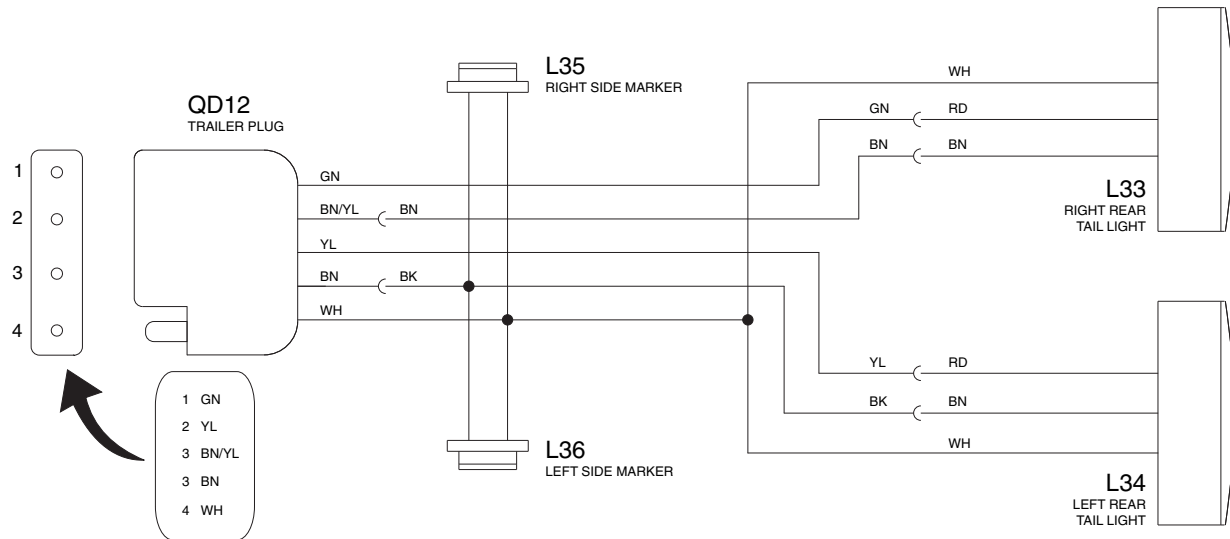

Trailer Lighting Wiring Diagram - Mechanical Axle, CE (to SN TZ5012-215)

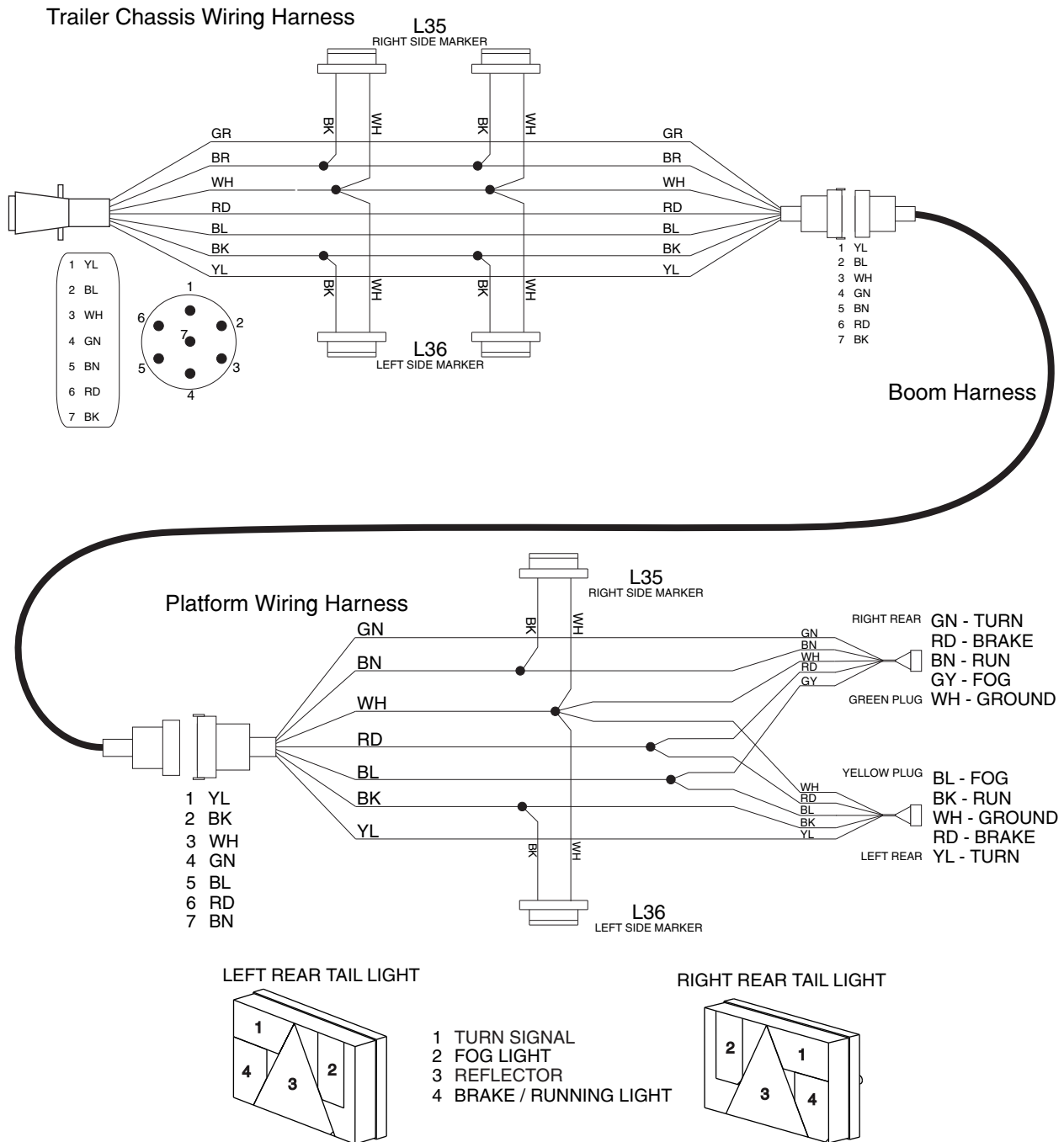

Trailer Lighting Wiring Diagram - Mechanical Axle, CE (from SN TZ5012-216)

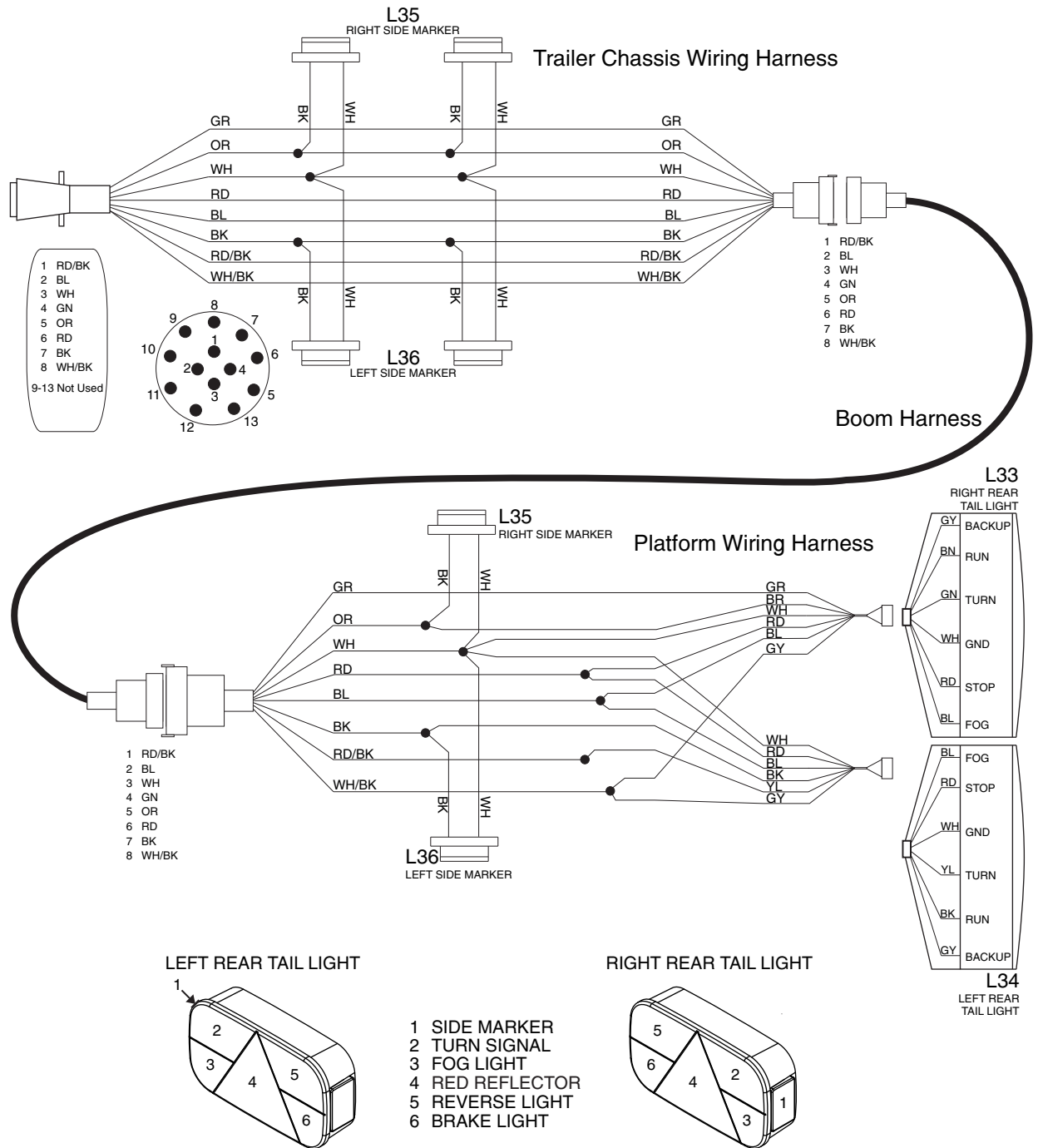

Trailer Lighting Wiring Diagram - Electric Axle, AUS (to SN TZ5012-252)

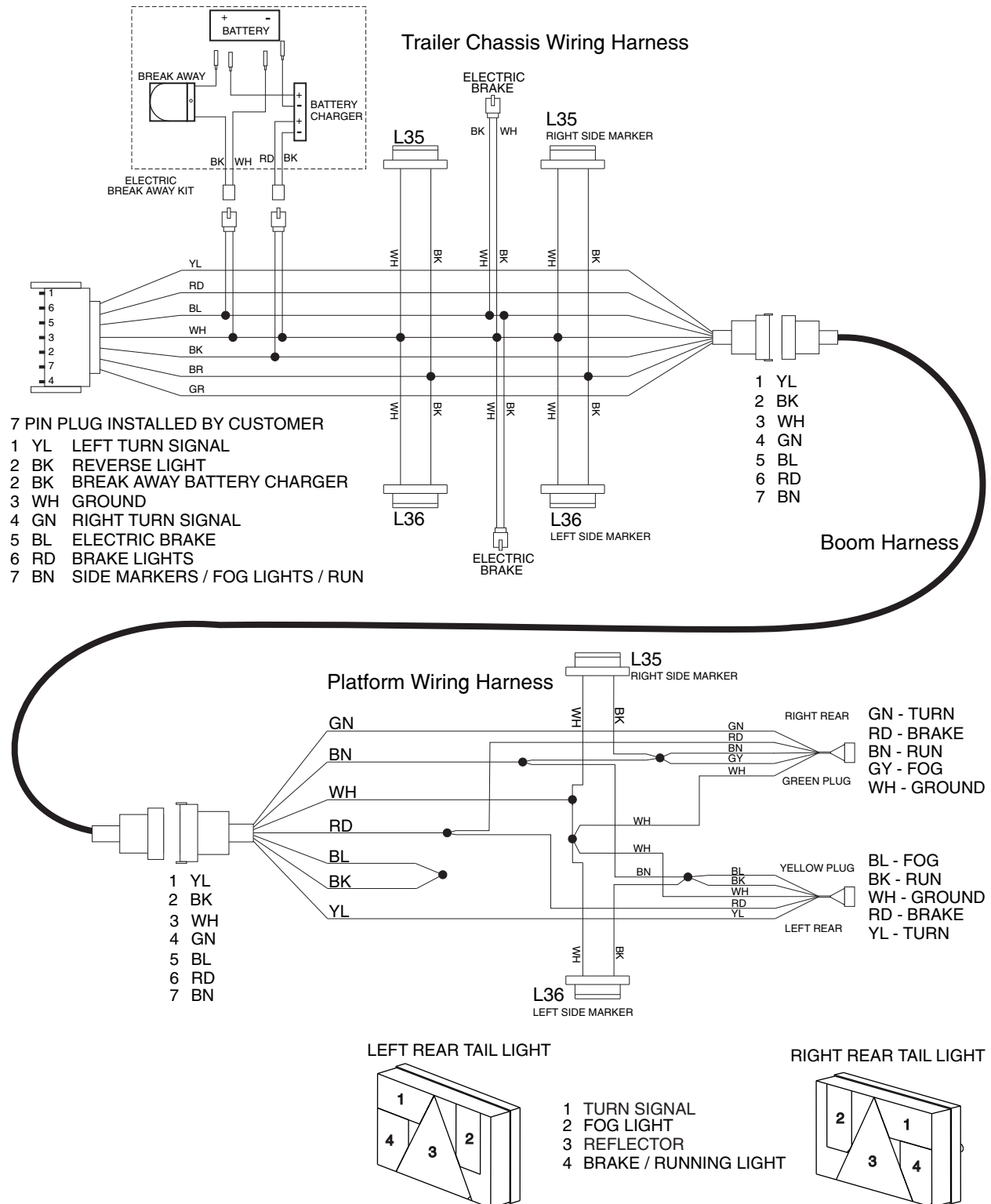

Trailer Lighting Wiring Diagram - Electric Axle, AUS (from SN TZ5012-253)

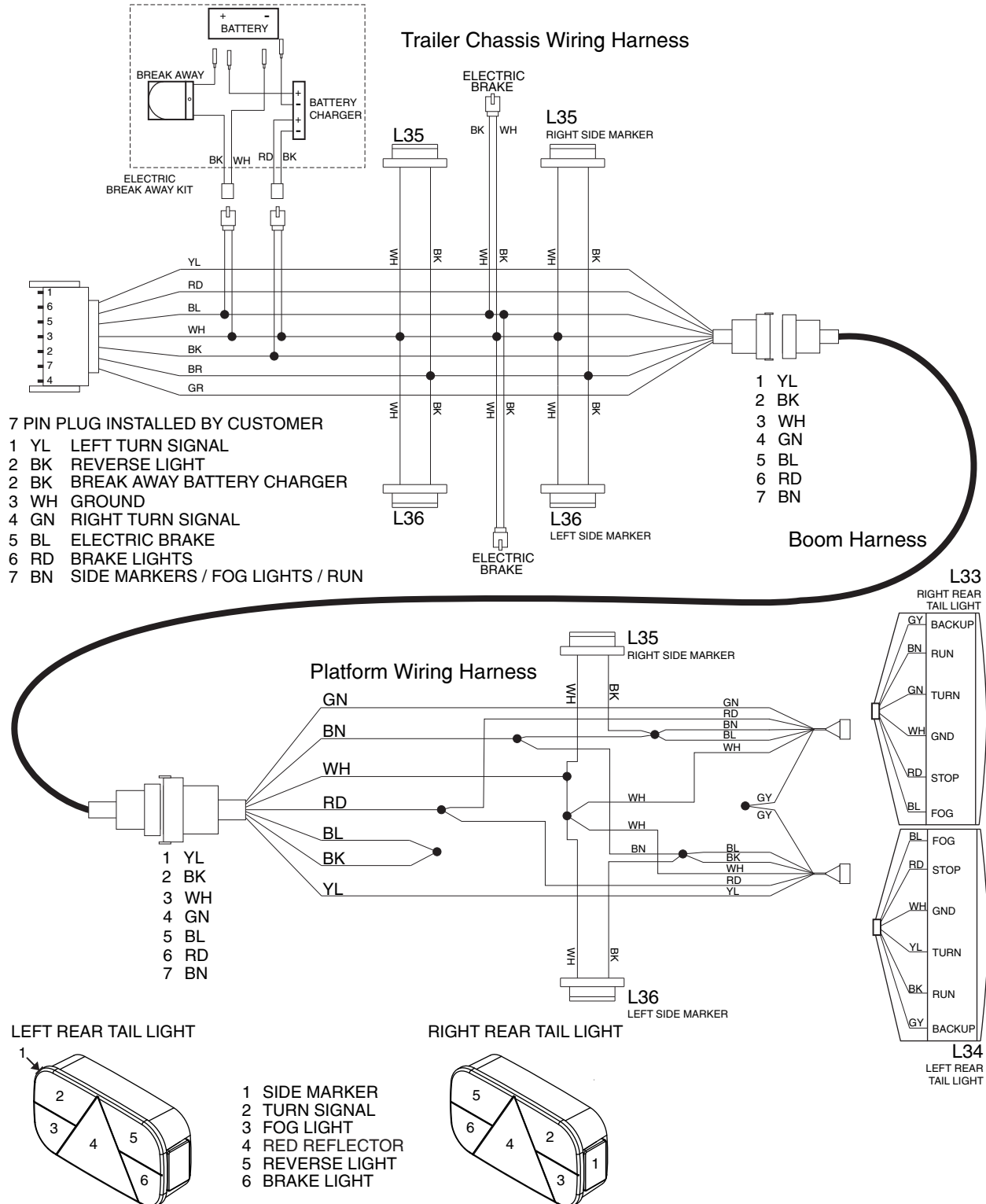

Trailer Lighting Wiring Diagram - Hydraulic Axle, AUS (from SN TZ5012-216)

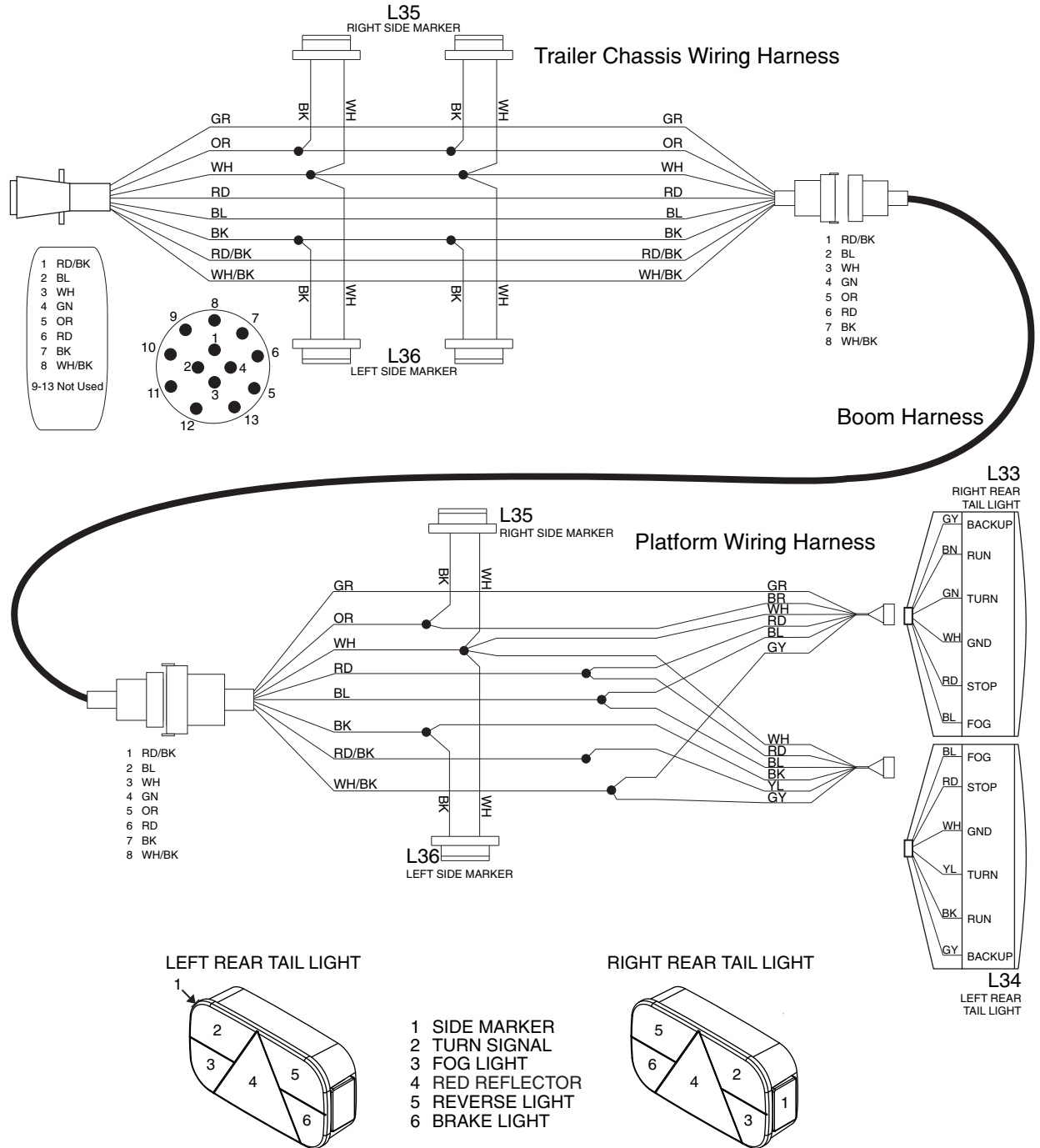

Ground Control Box Wiring Diagram - ANSI/CSA (to serial number TZ5004-181)

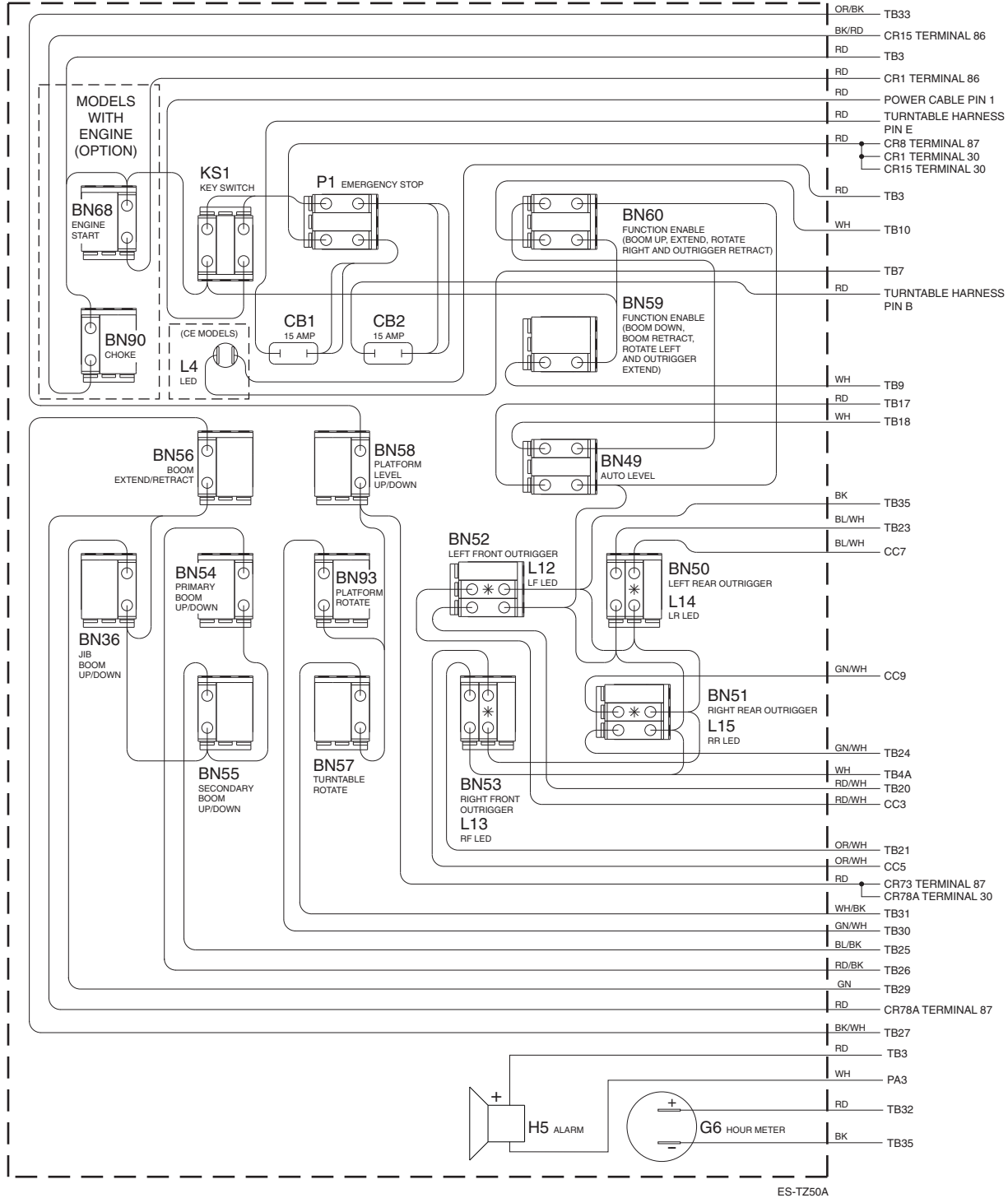

Ground Control Box Wiring Diagram - ANSI/CSA

(to serial number TZ5004-181)

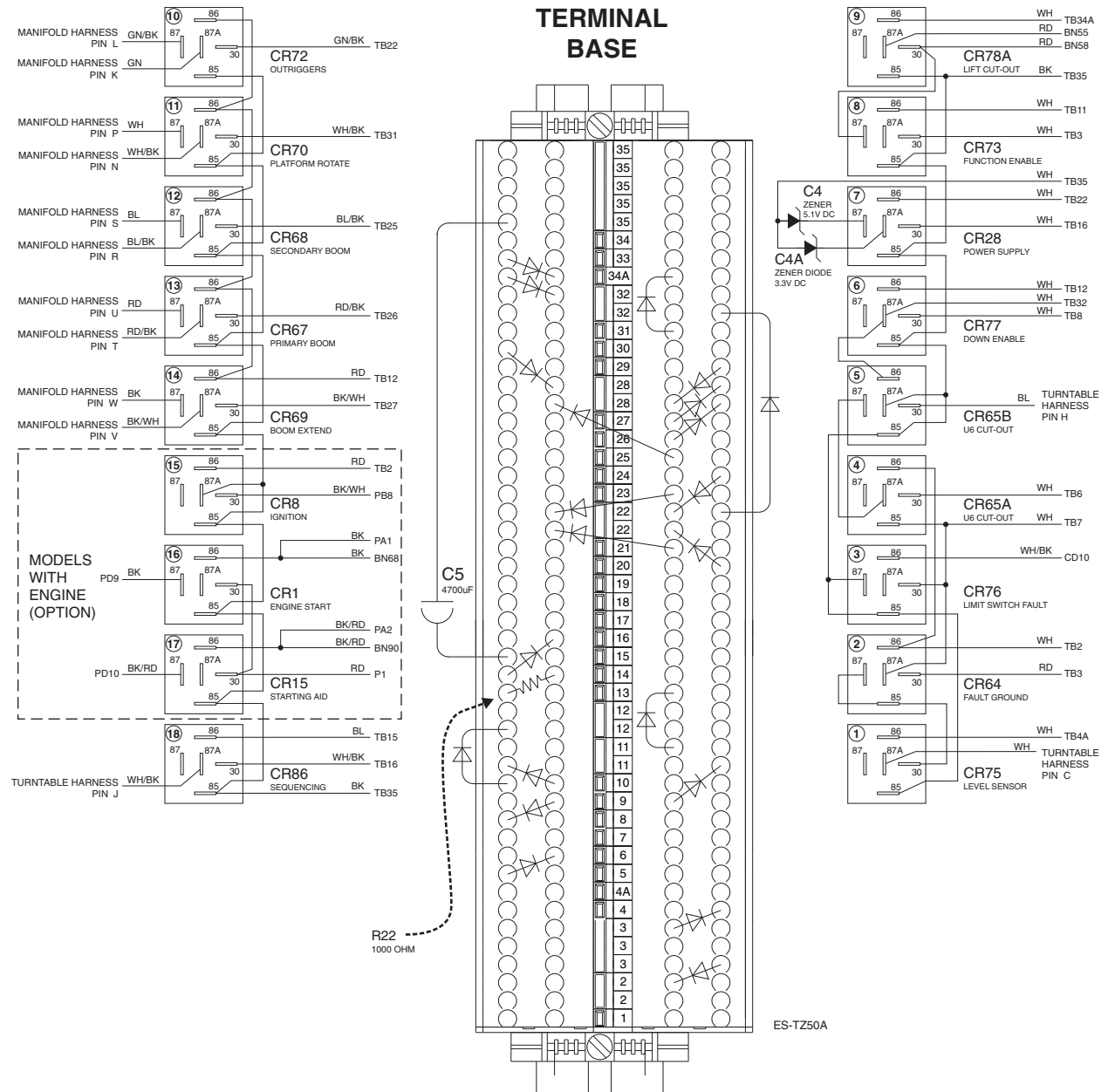

Ground Control Box Wiring Diagram - ANSI/CSA

(from serial number TZ5004-182 to TZ5004-324)

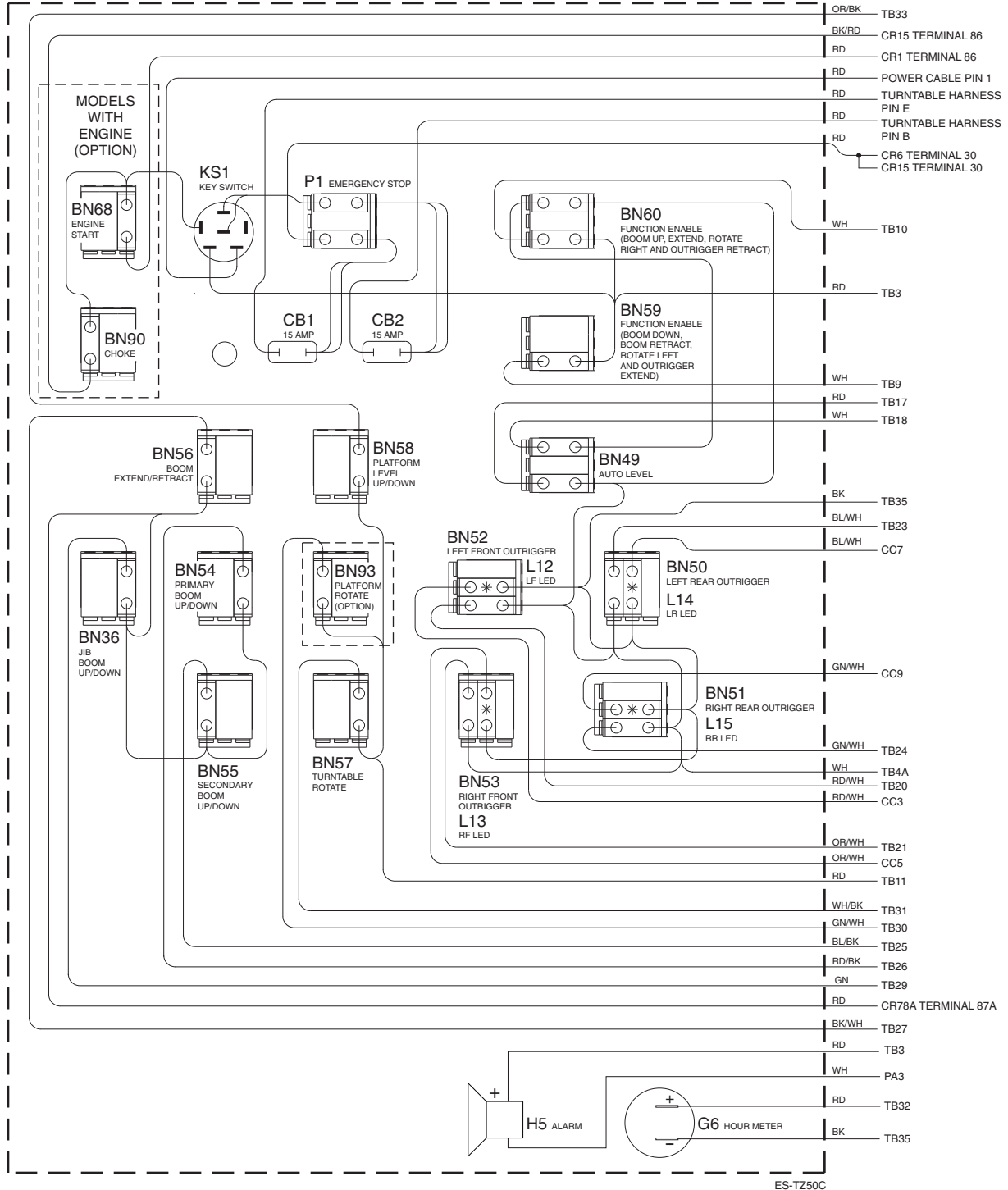

ES-TZ50C



Ground Control Box Wiring Diagram - ANSI/CSA

(from serial number TZ5004-182 to TZ5004-324)

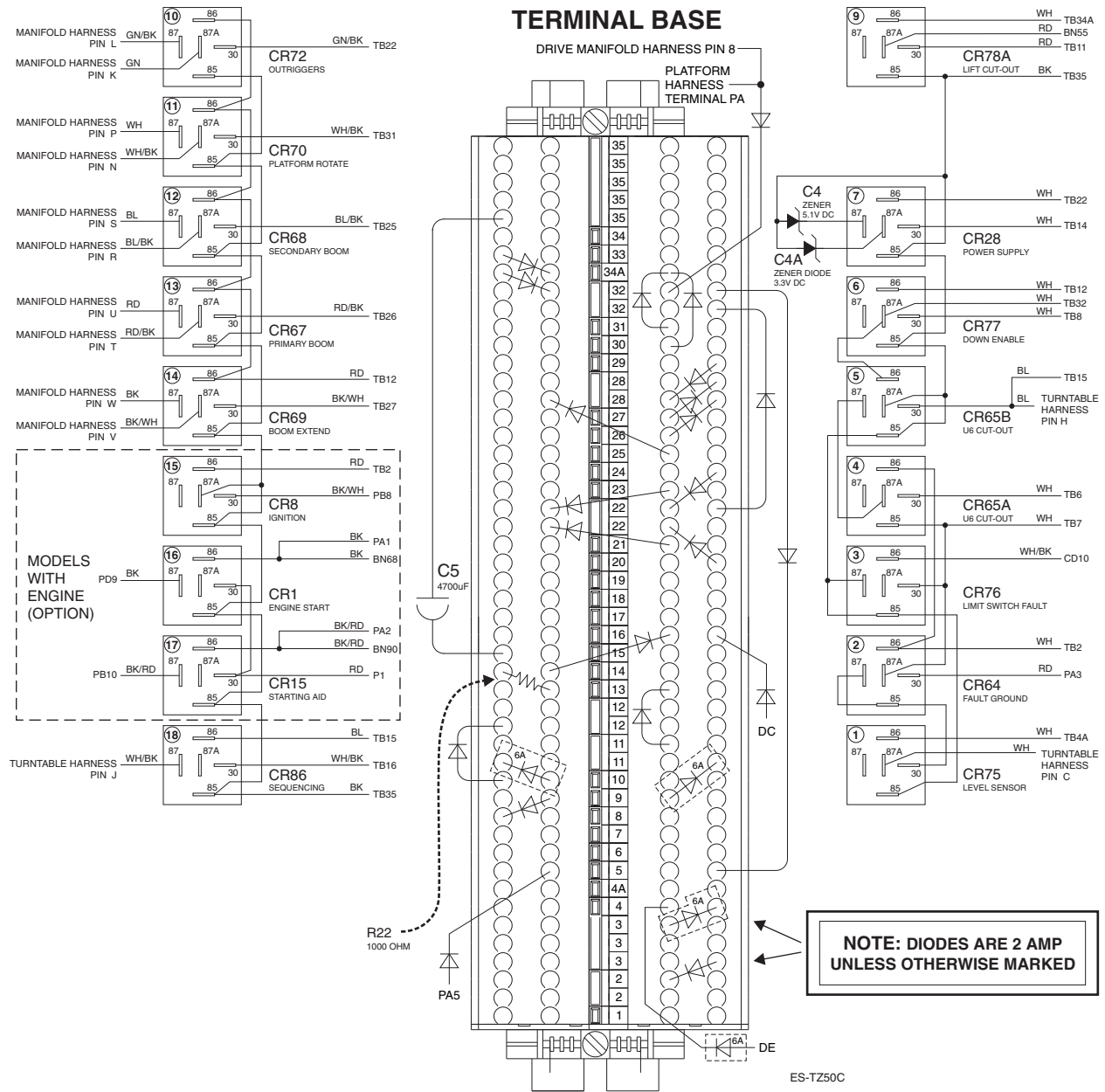

Ground Control Box Wiring Diagram - ANSI/CSA

(from serial number TZ5004-325 to TZ5005-284)

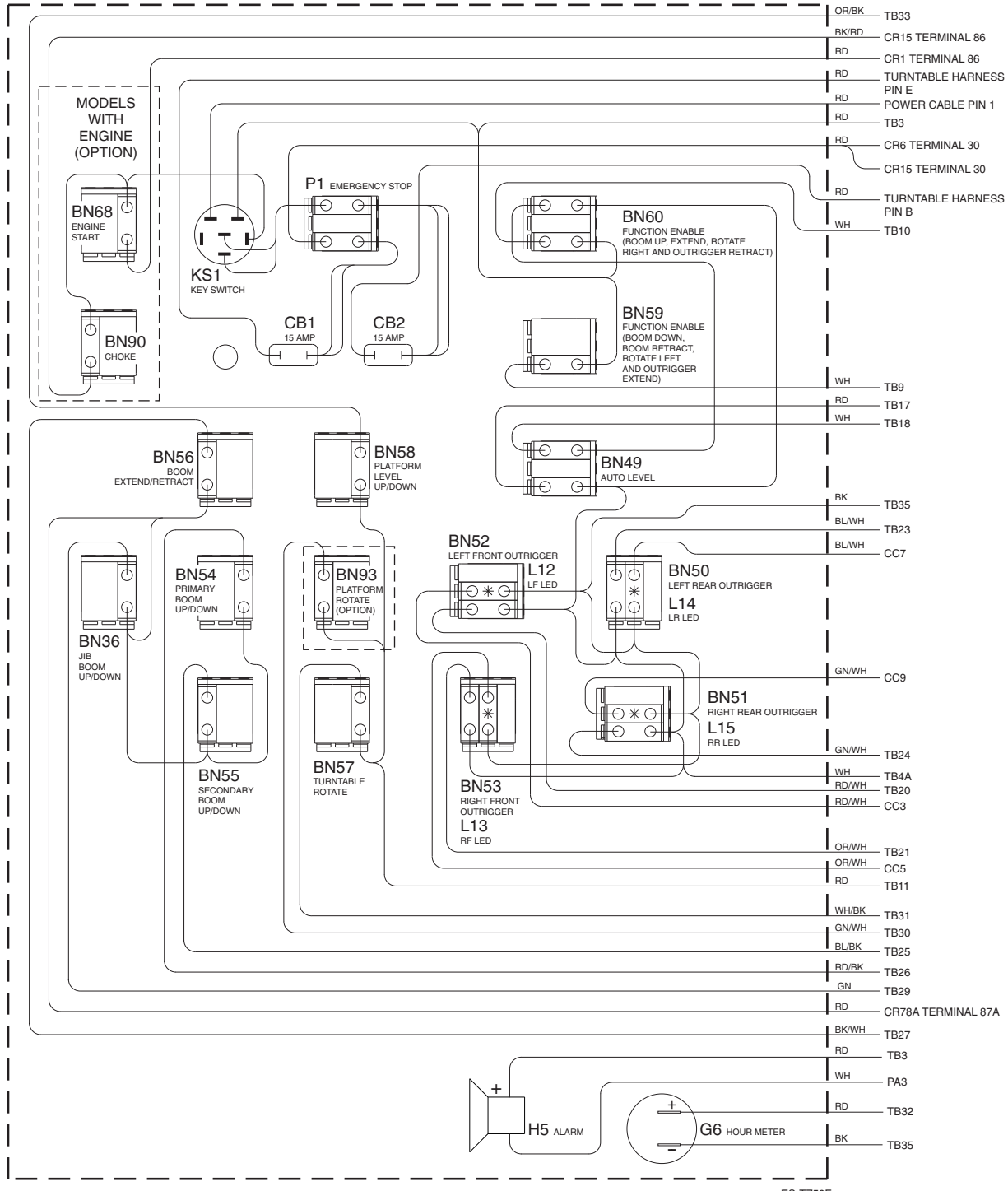

ES-TZ50F

Ground Control Box Wiring Diagram - ANSI/CSA

(from serial number TZ5004-325 to TZ5005-284)

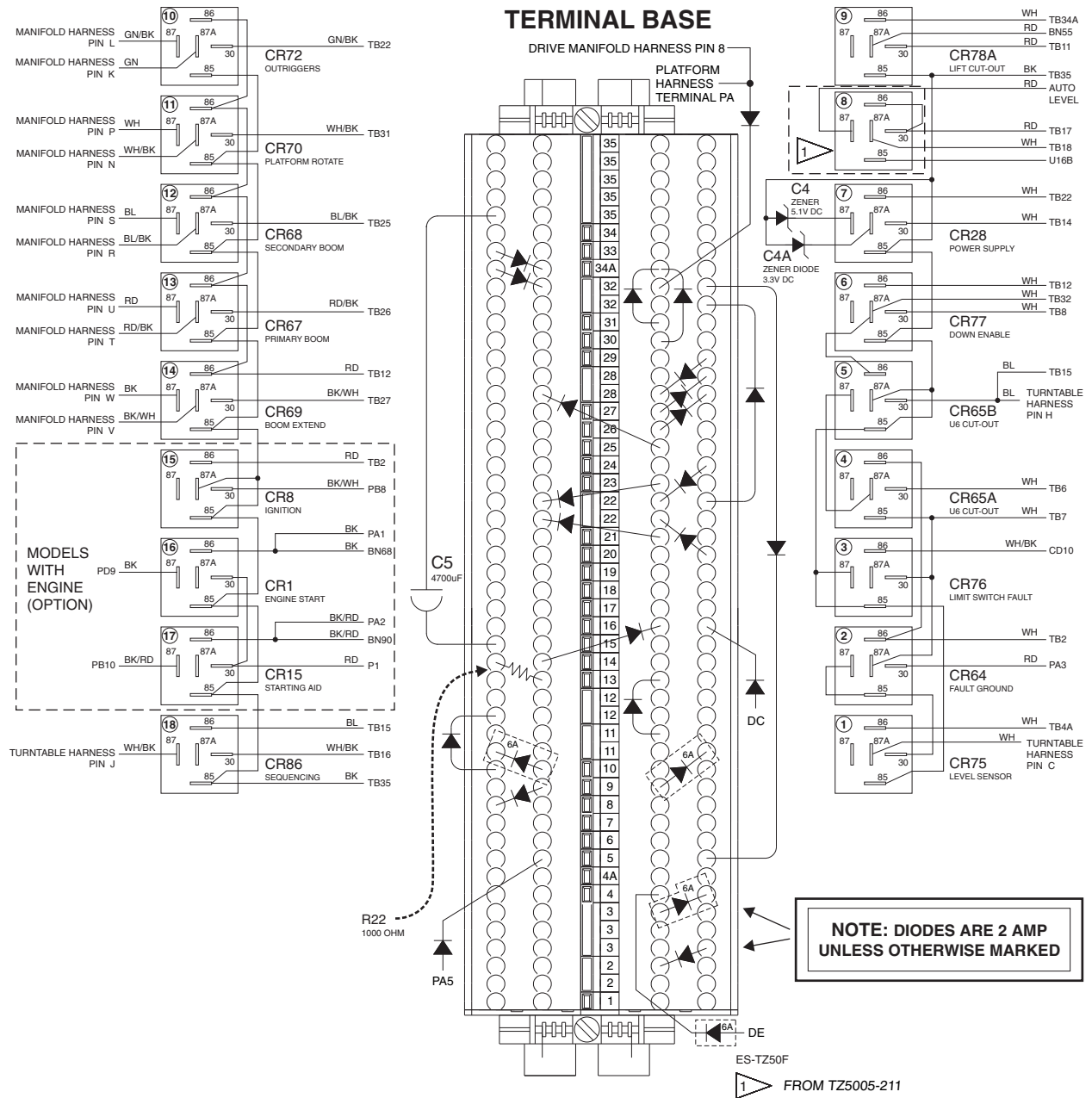

Ground Control Box Wiring Diagram - ANSI/CSA

(from serial number TZ5005-285 to TZ5010-144)

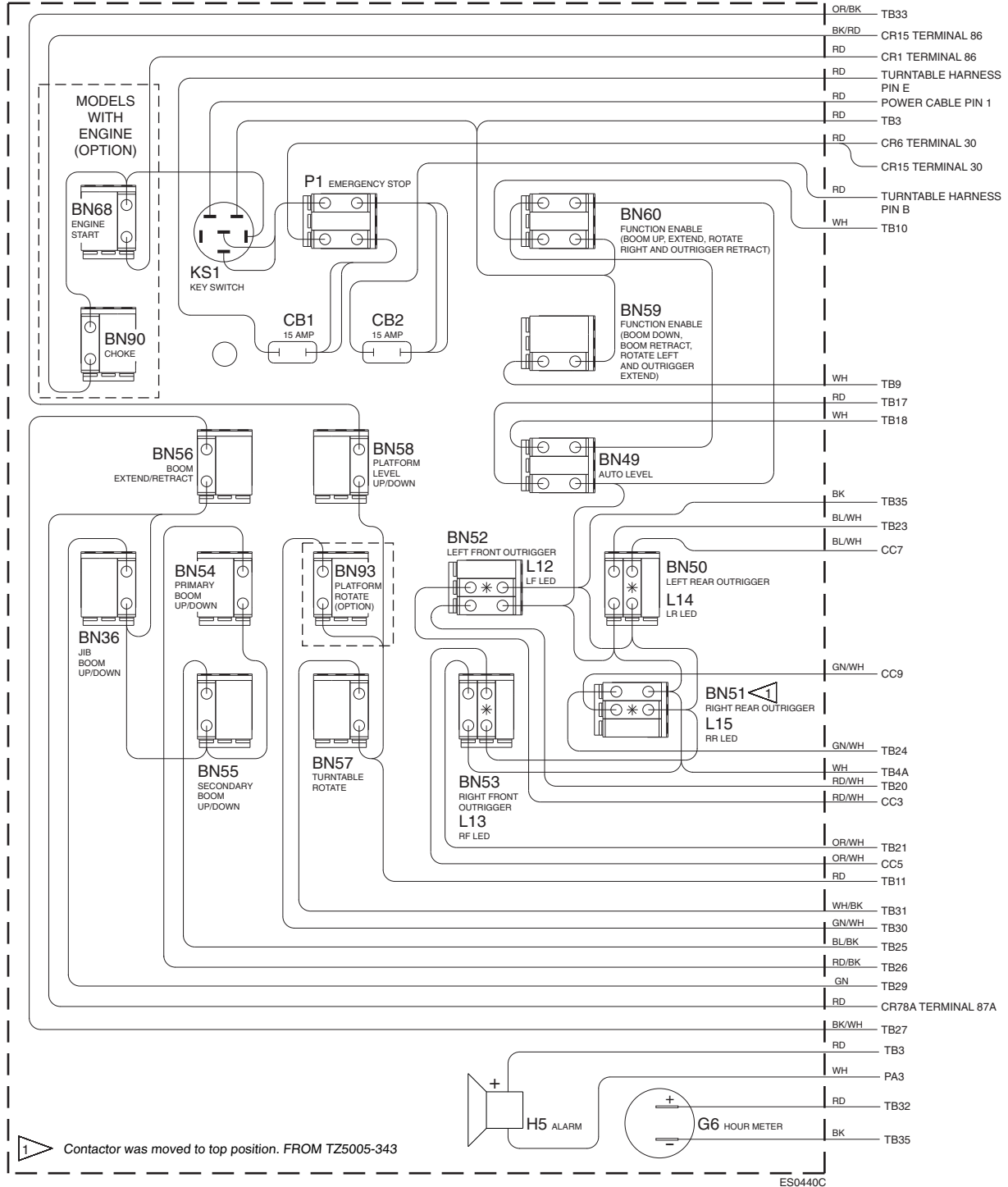

Ground Control Box Wiring Diagram - ANSI/CSA

(from serial number TZ5005-285 to TZ5010-144)

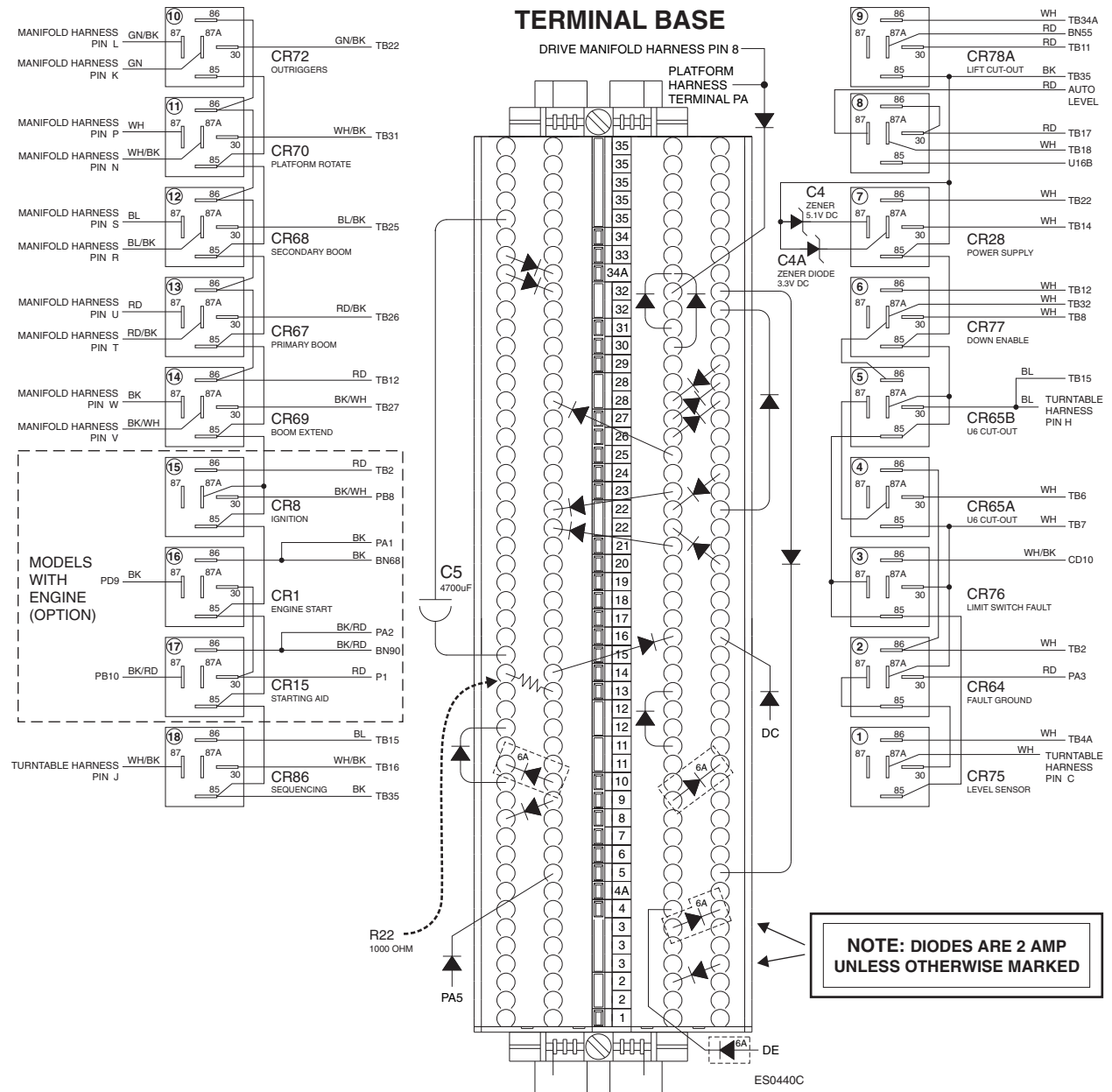

Ground Control Box Wiring Diagram - ANSI/CSA

(from serial number TZ5010-145 to TZ5011-131)

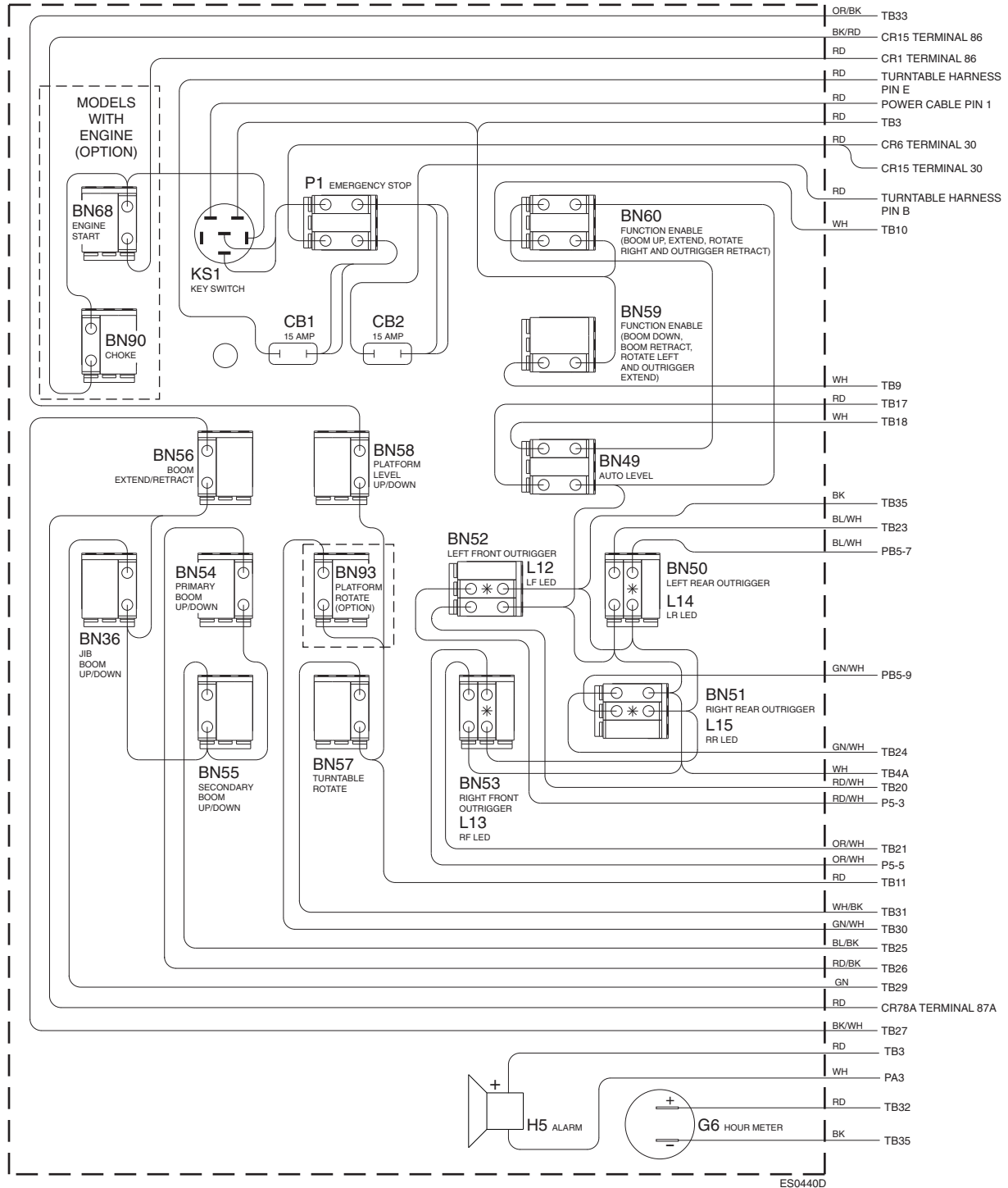

Ground Control Box Wiring Diagram - ANSI/CSA

(from serial number TZ5011-132)

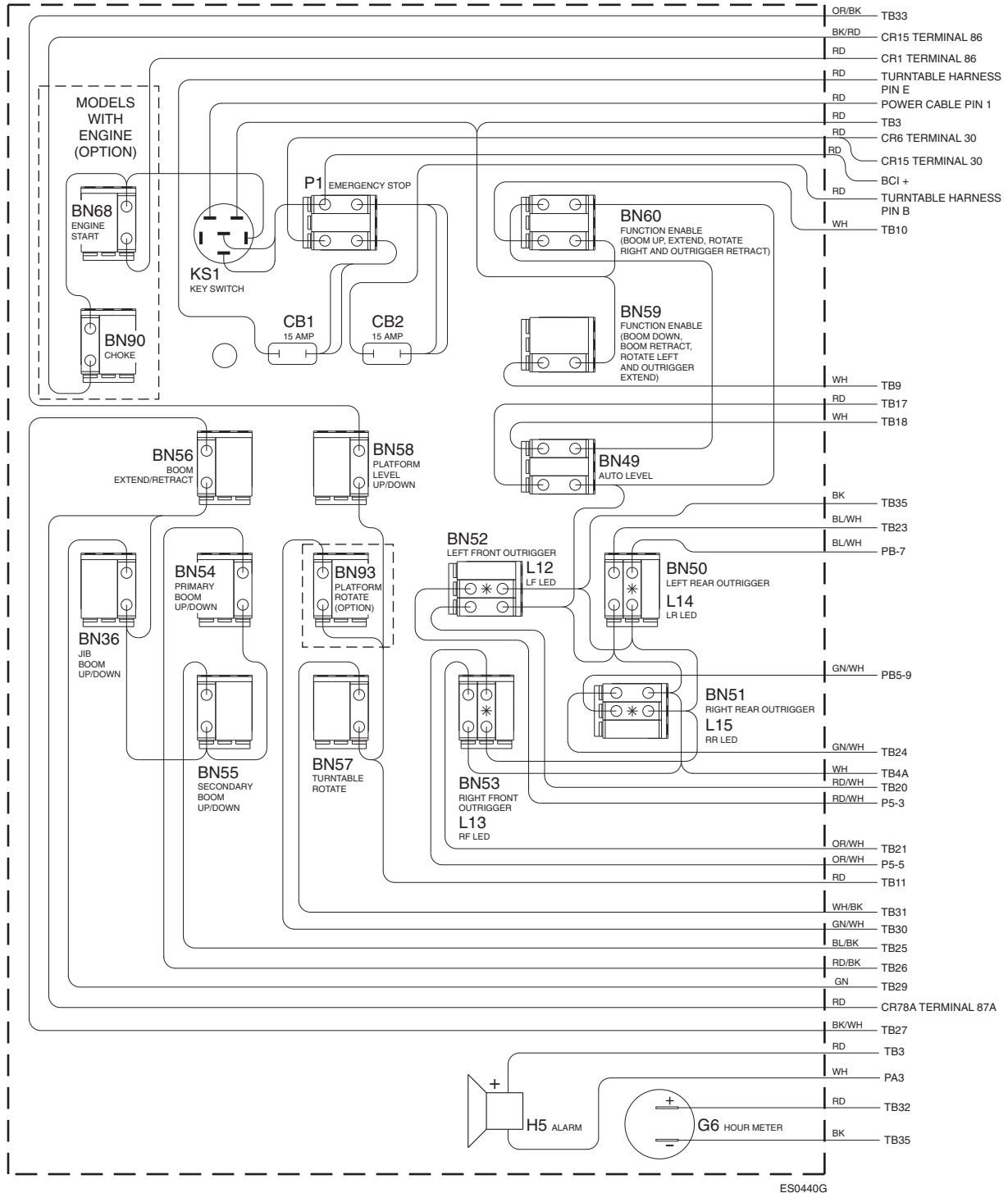

ES0440G



Ground Control Box Wiring Diagram - ANSI/CSA

(from serial number TZ5011-132)

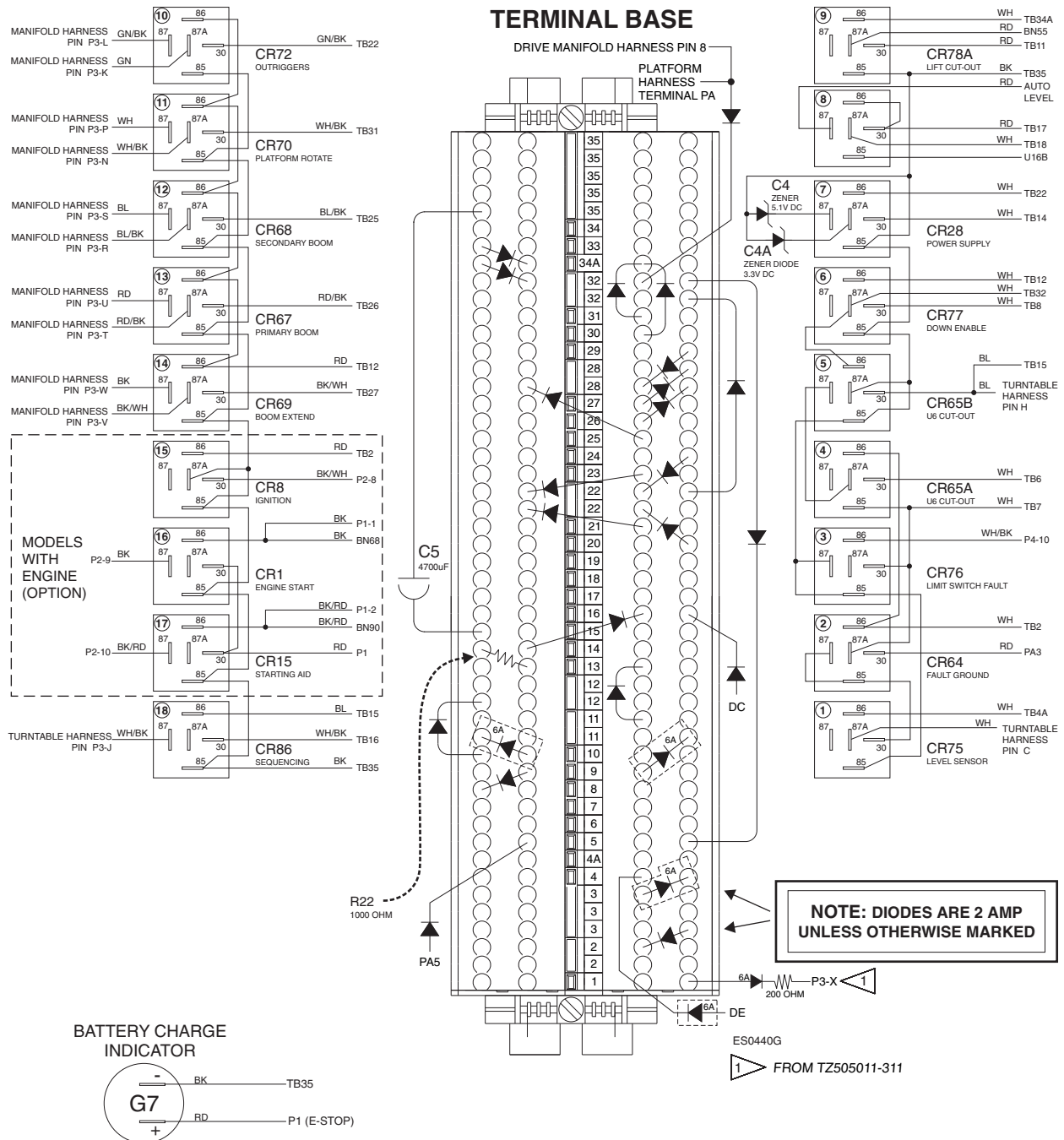

Platform Control Box Wiring Diagram - ANSI/CSA

(from serial number TZ5004-182 to TZ5005-284)

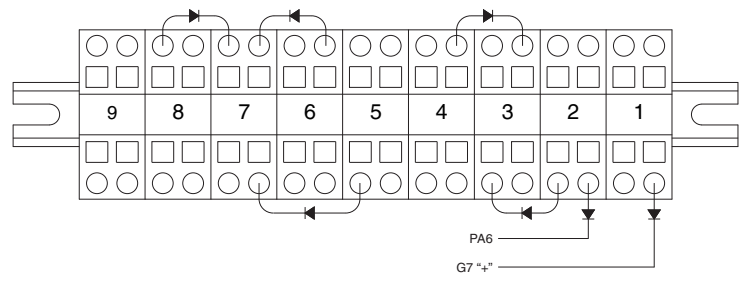
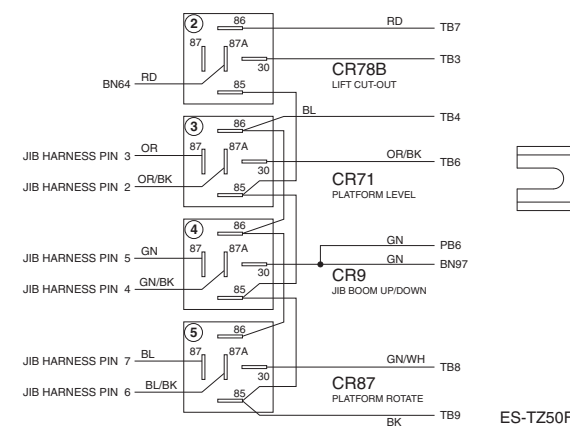
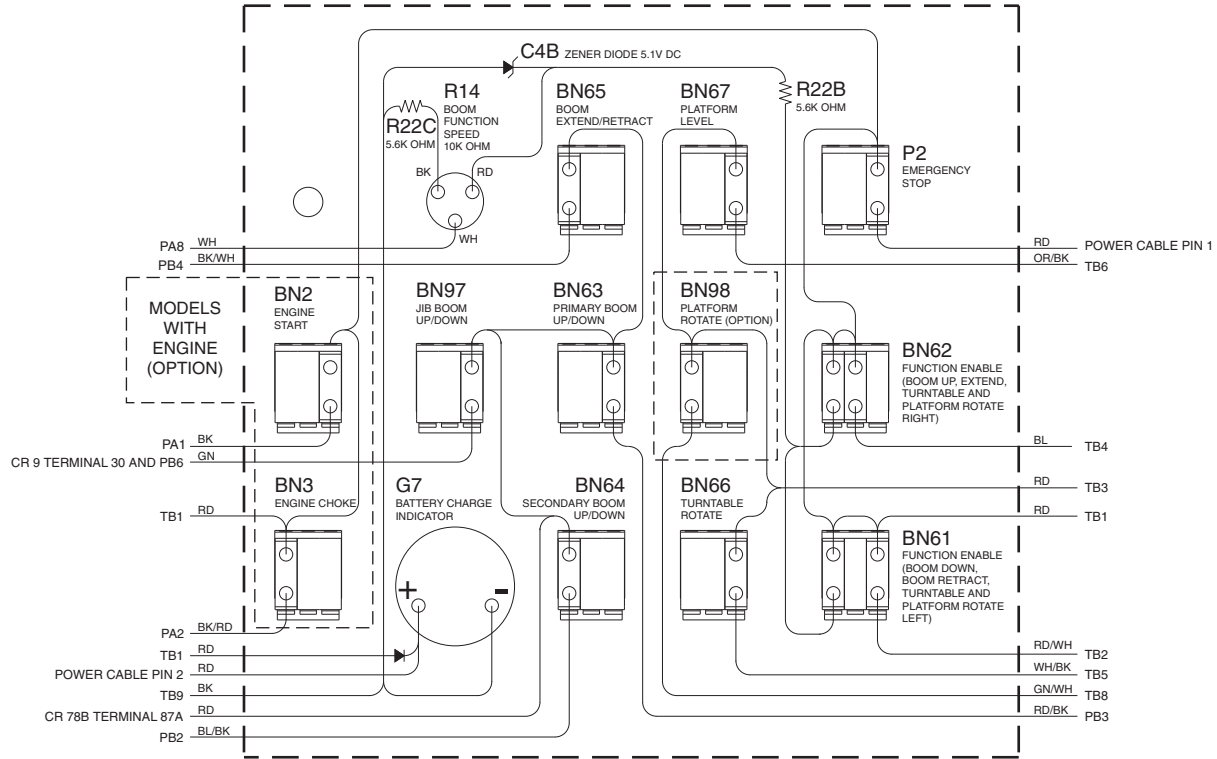

ES-TZ50F



Platform Control Box Wiring Diagram - ANSI/CSA

(from serial number TZ5005-285 to TZ5010-144)

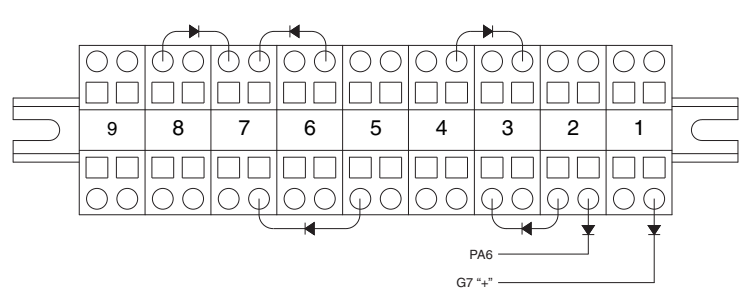
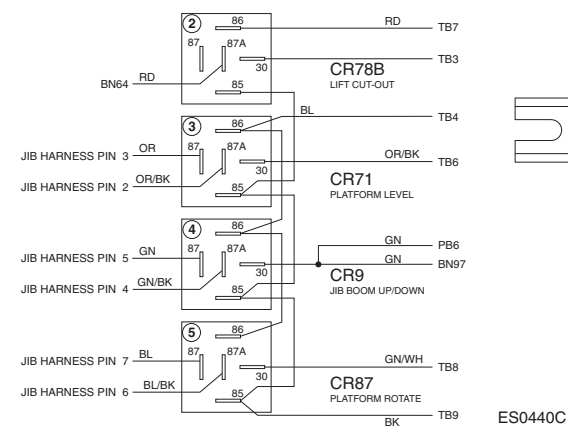
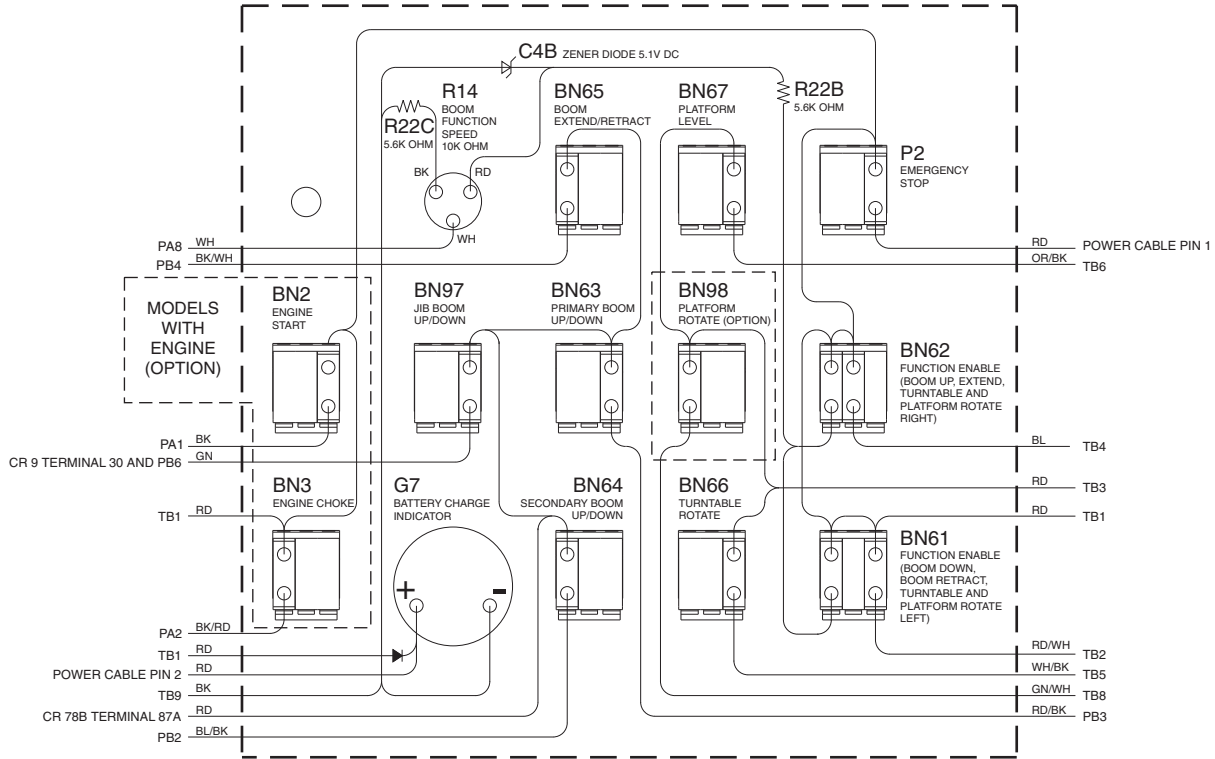

ES0440C

Platform Control Box Wiring Diagram - ANSI/CSA

(from serial number TZ5010-145 to TZ5011-131)

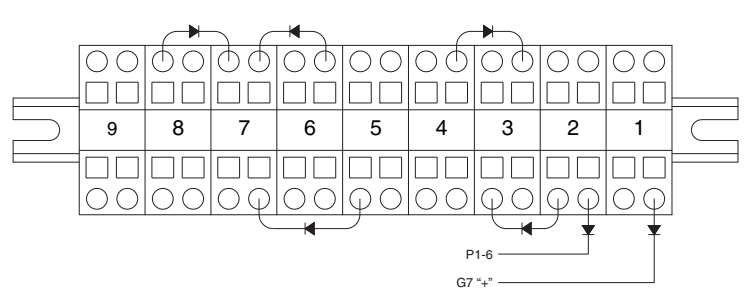
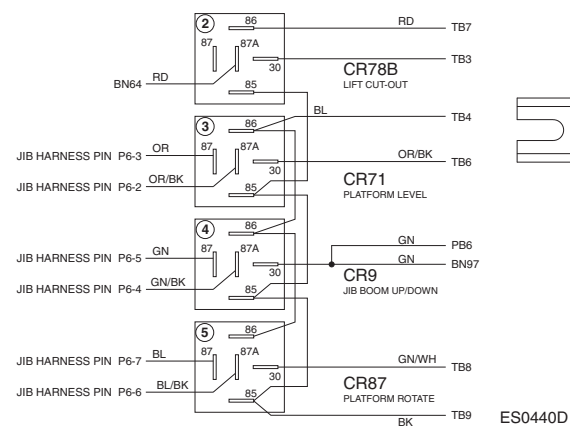
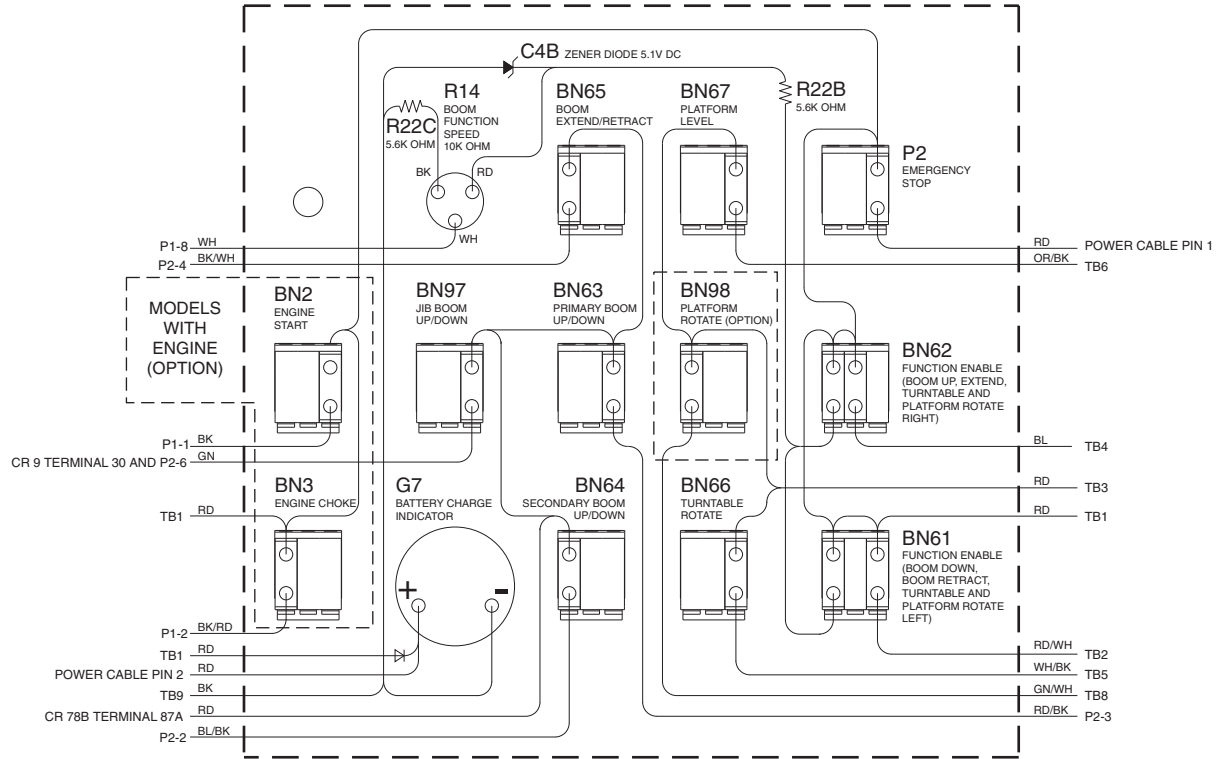

ES0440D



Platform Control Box Wiring Diagram - ANSI/CSA

(from serial number TZ5011-132)

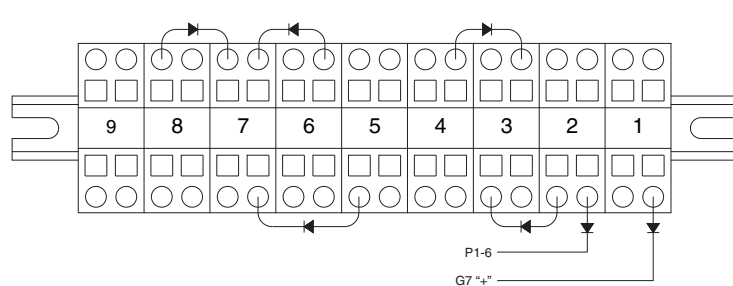
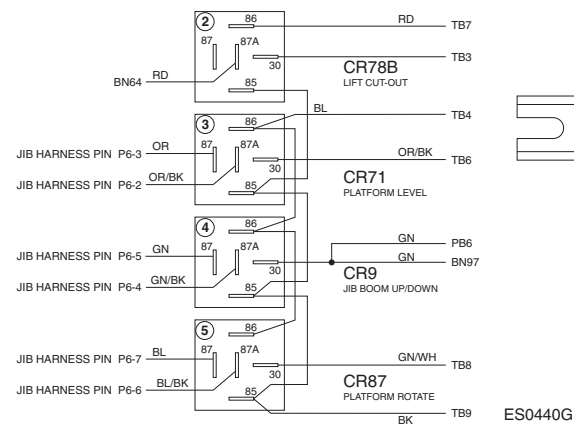
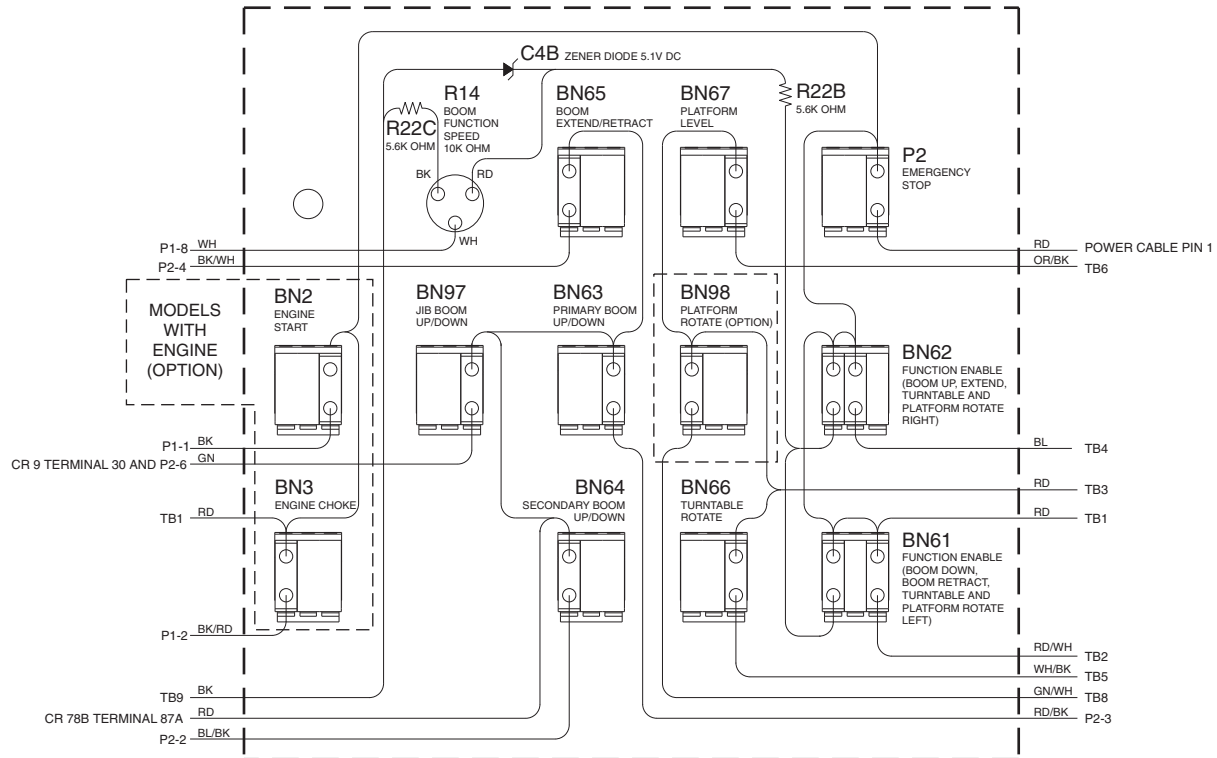

ES0440G

Drive Control Box Wiring Diagram - ANSI/CSA (to serial number TZ5004-284)

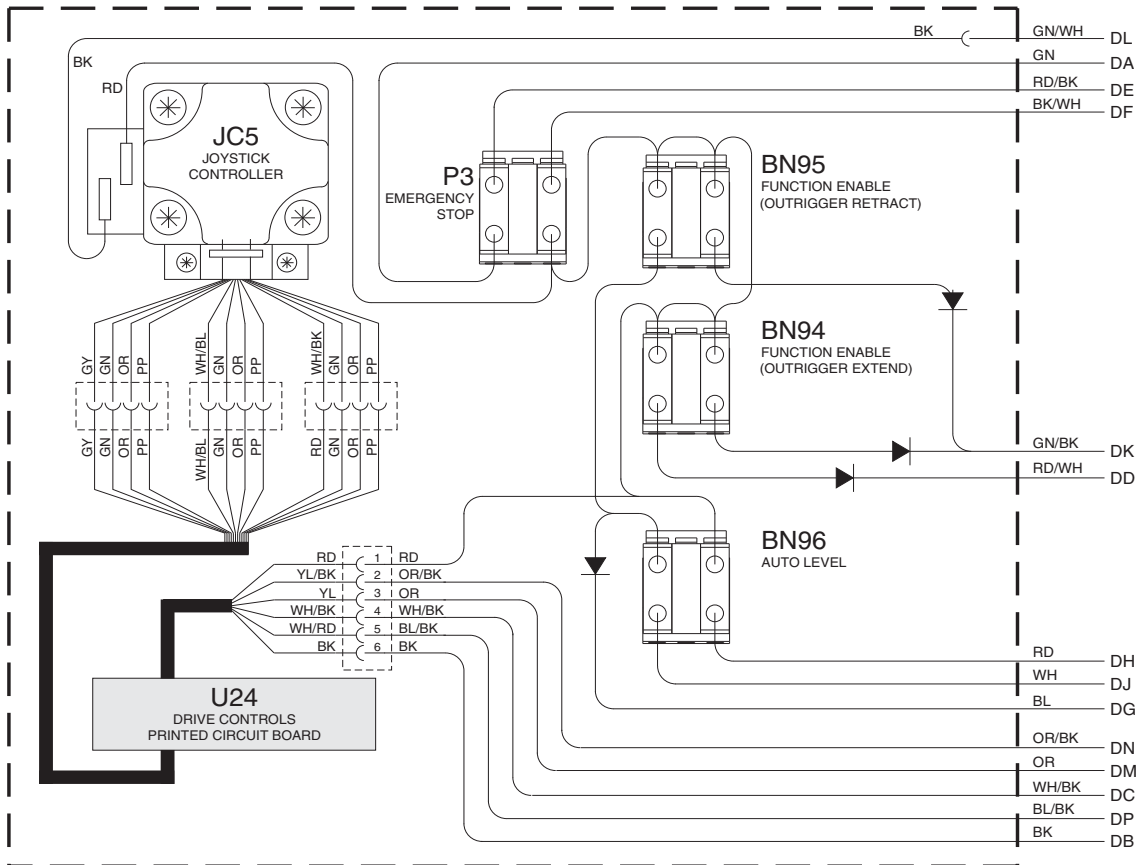

FROM TZ5005-285 REFER TO THE ELECTRICAL SCHEMATIC
FOR YOUR MODEL AND SERIAL NUMBER.

Ground Control Box Wiring Diagram - AS/CE

(to serial number TZ5004-181)

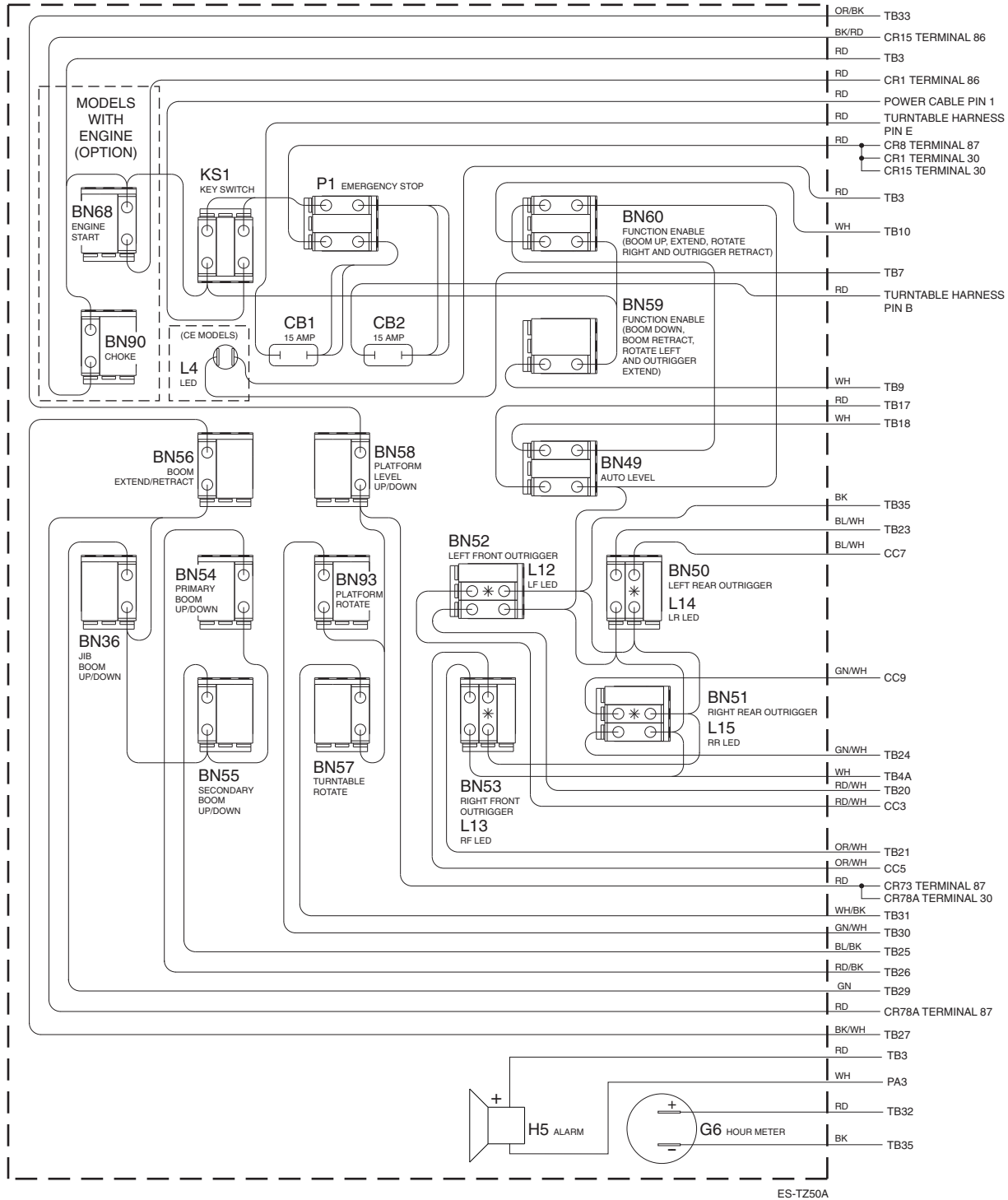

ES-TZ50A

Ground Control Box Wiring Diagram - - AS/CE

(to serial number TZ5004-181)

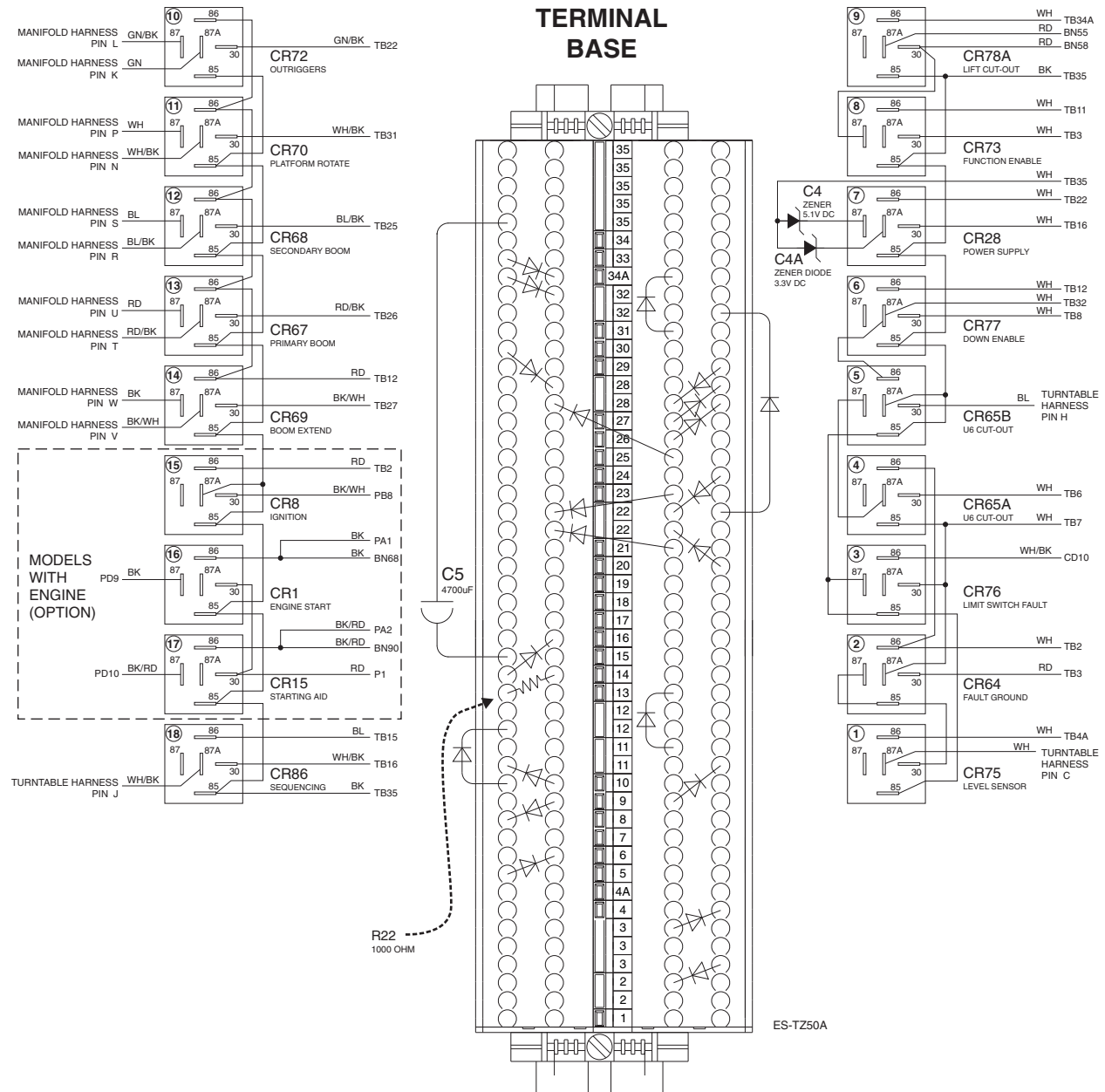

Ground Control Box Wiring Diagram - AS/CE

(from serial number TZ5004-182 to TZ5004-324)

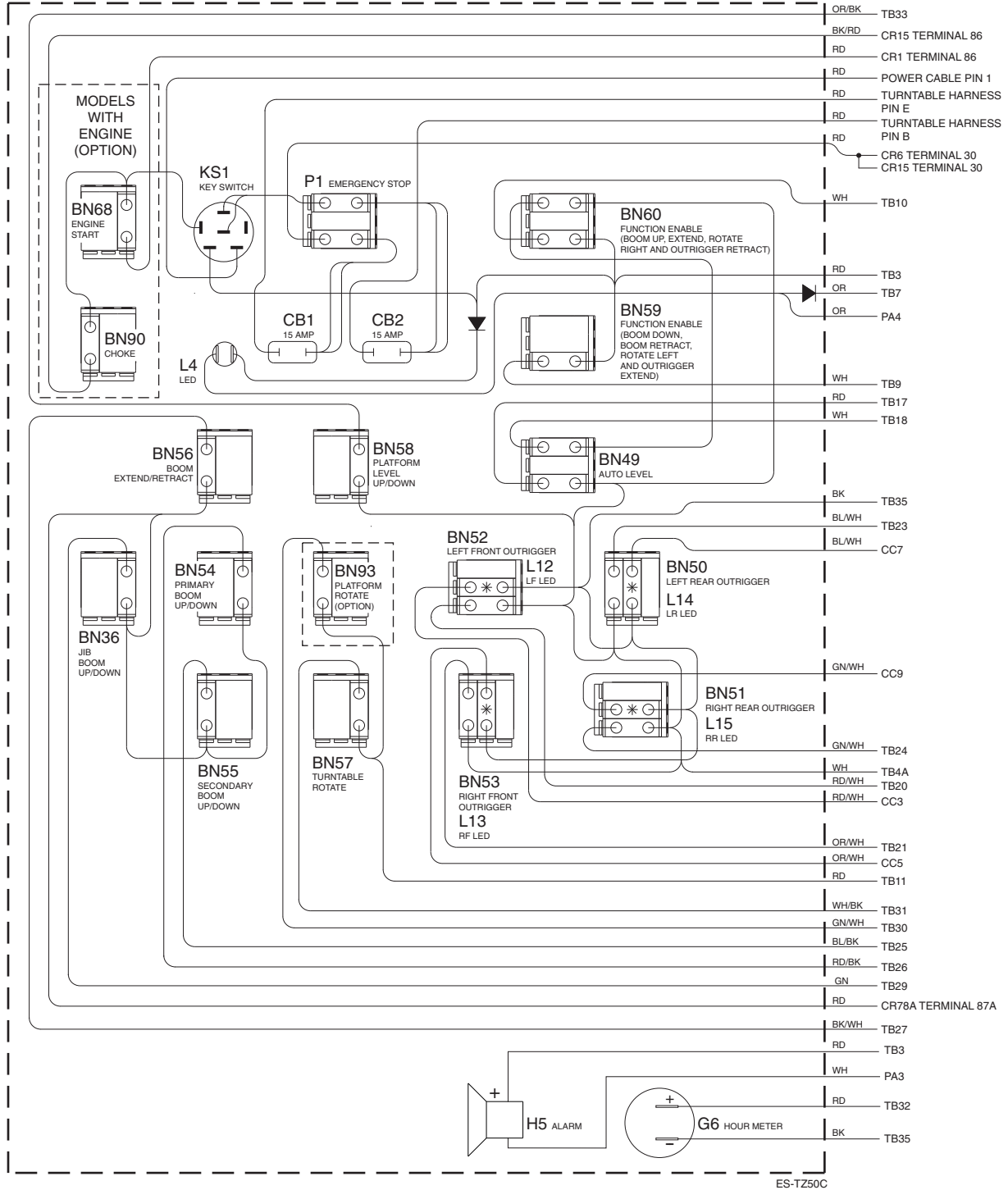

Ground Control Box Wiring Diagram - AS/CE

(from serial number TZ5004-182 to TZ5004-324)

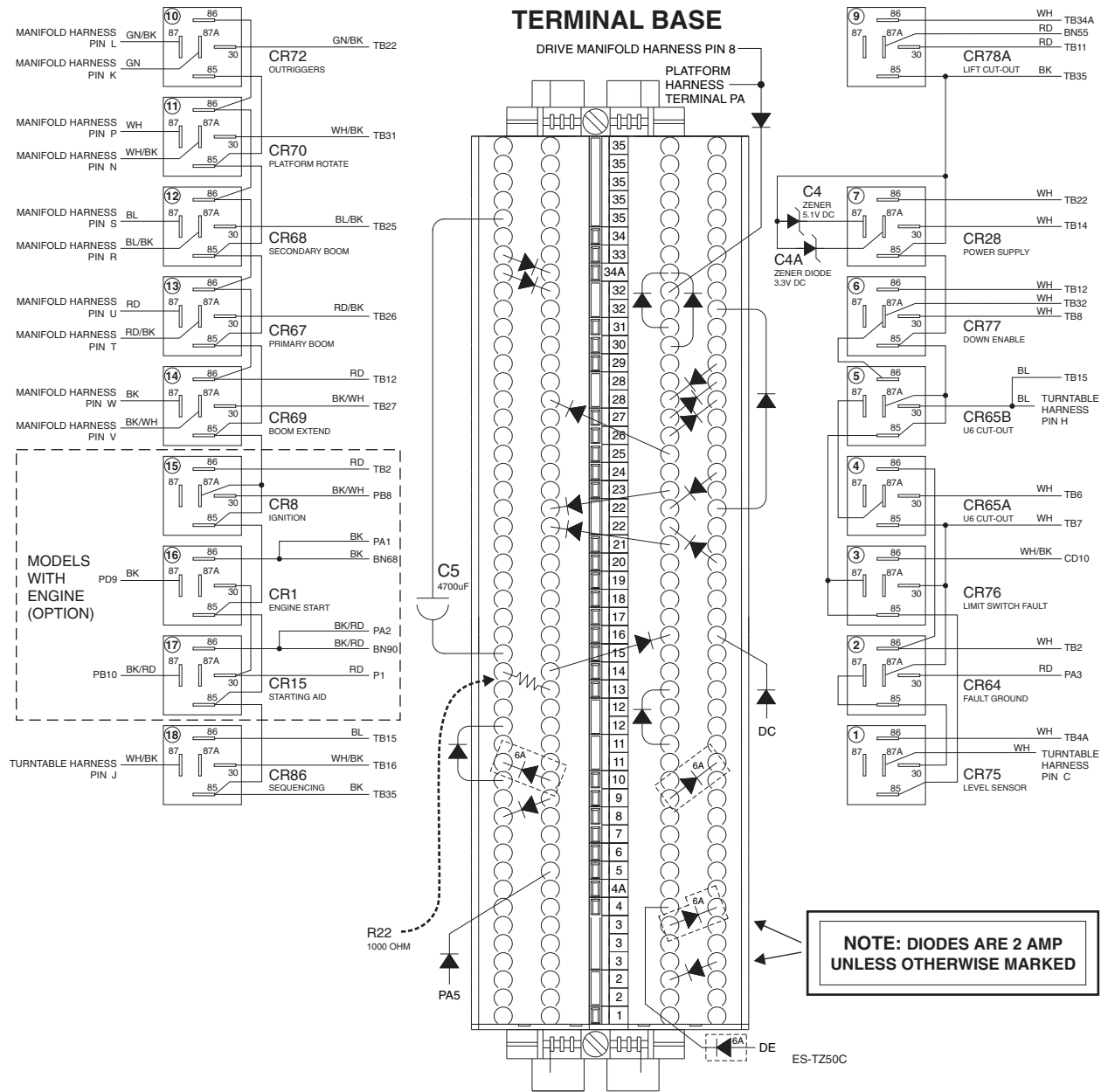

Ground Control Box Wiring Diagram - AS/CE

(from serial number TZ5004-325 to TZ5005-284)

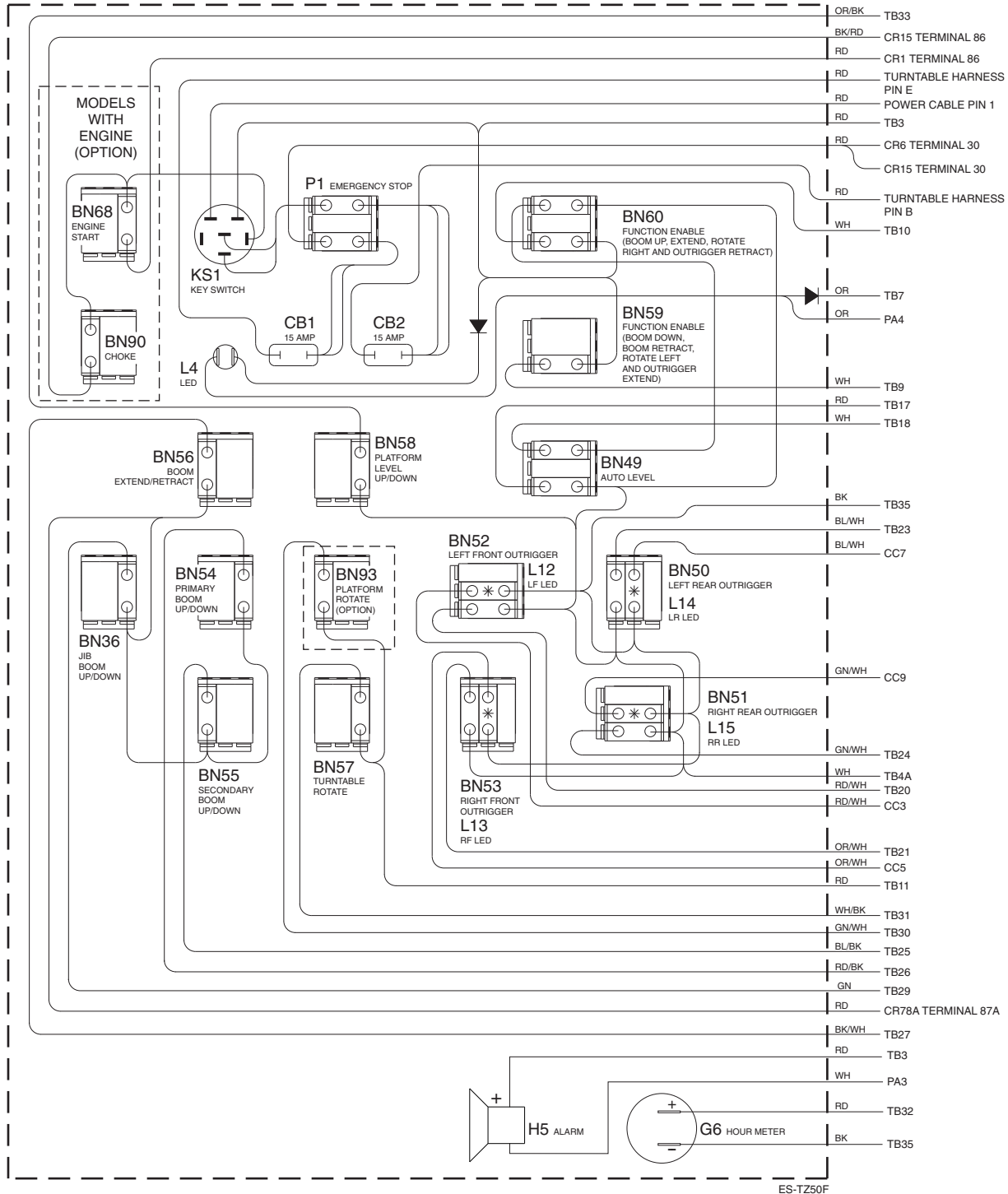

Ground Control Box Wiring Diagram - AS/CE

(from serial number TZ5004-325 to TZ5005-284)

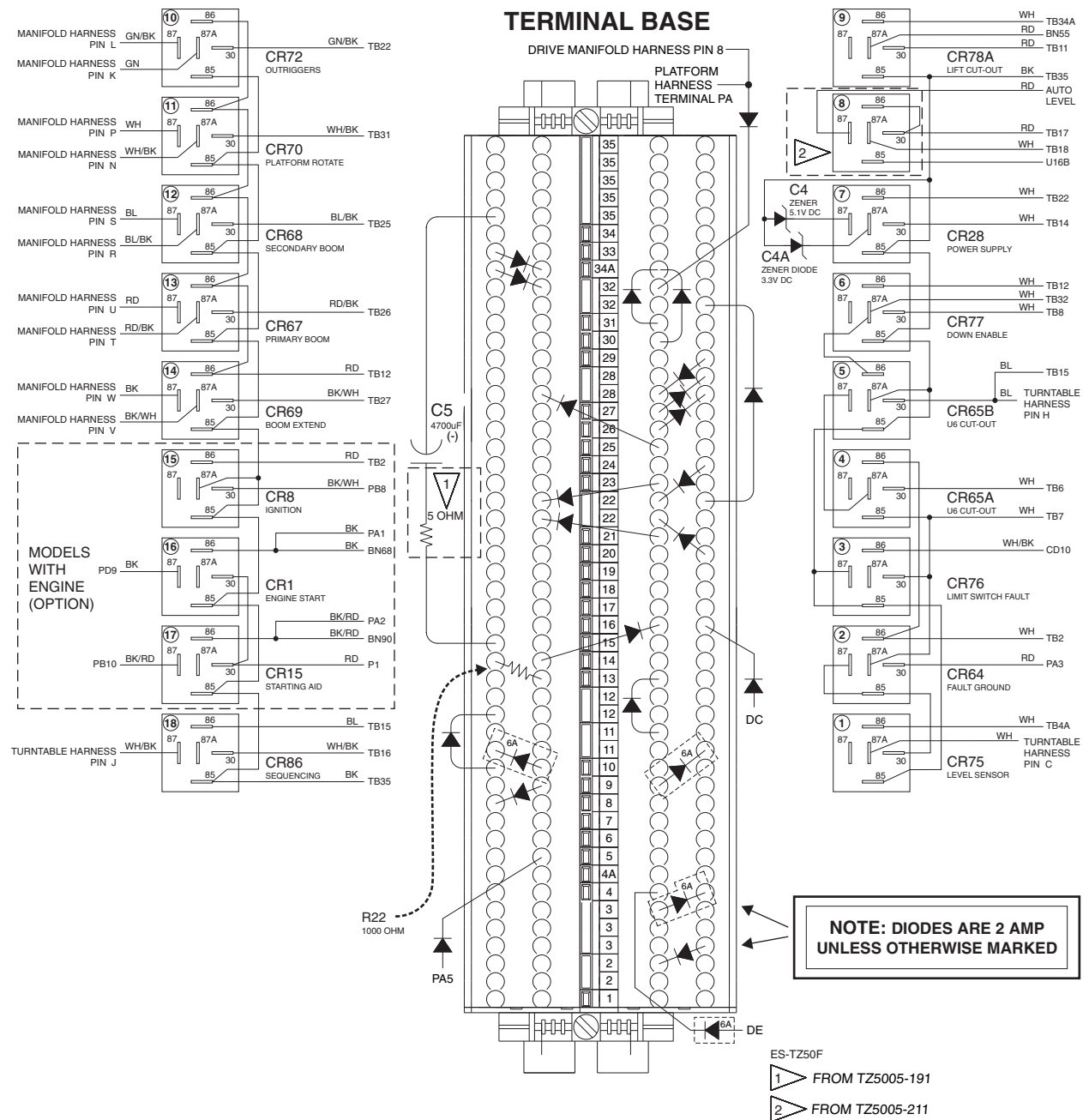

Ground Control Box Wiring Diagram - AS/CE

(from serial number TZ5005-285 to TZ5010-144)

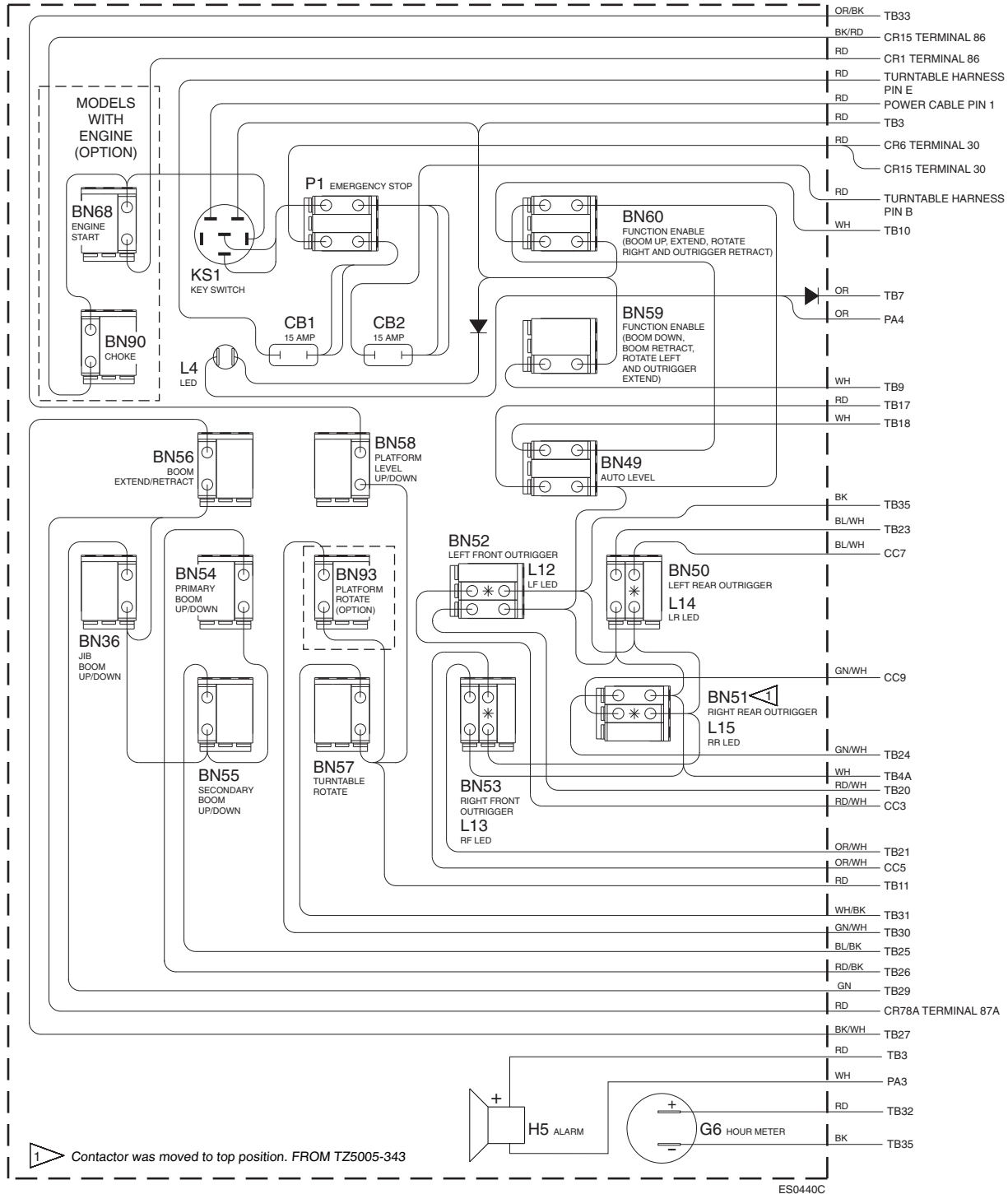

Ground Control Box Wiring Diagram - AS/CE

(from serial number TZ5005-285 to TZ5010-144)

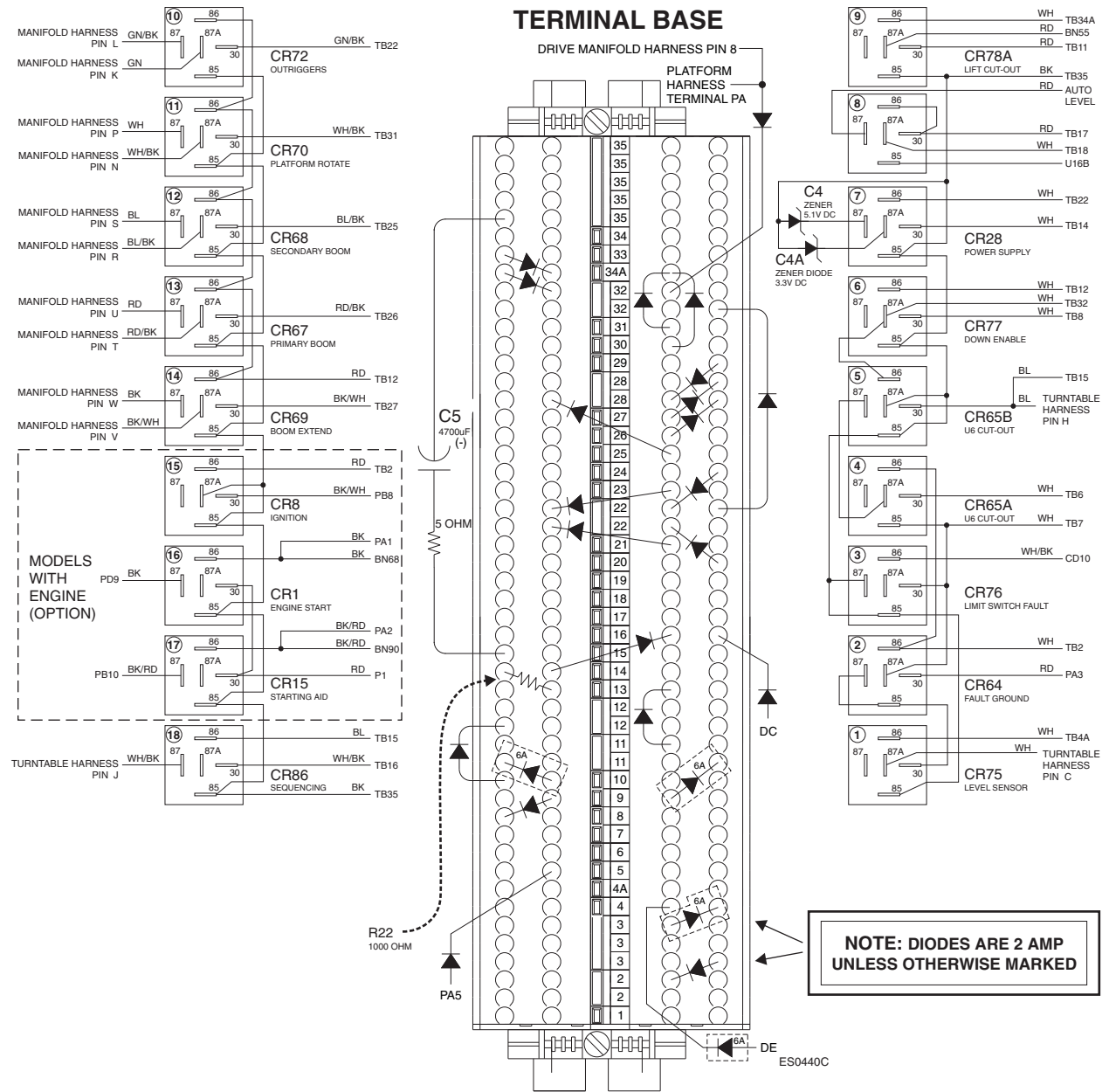

Ground Control Box Wiring Diagram - AS/CE

(from serial number TZ5010-145 to TZ5011-131)

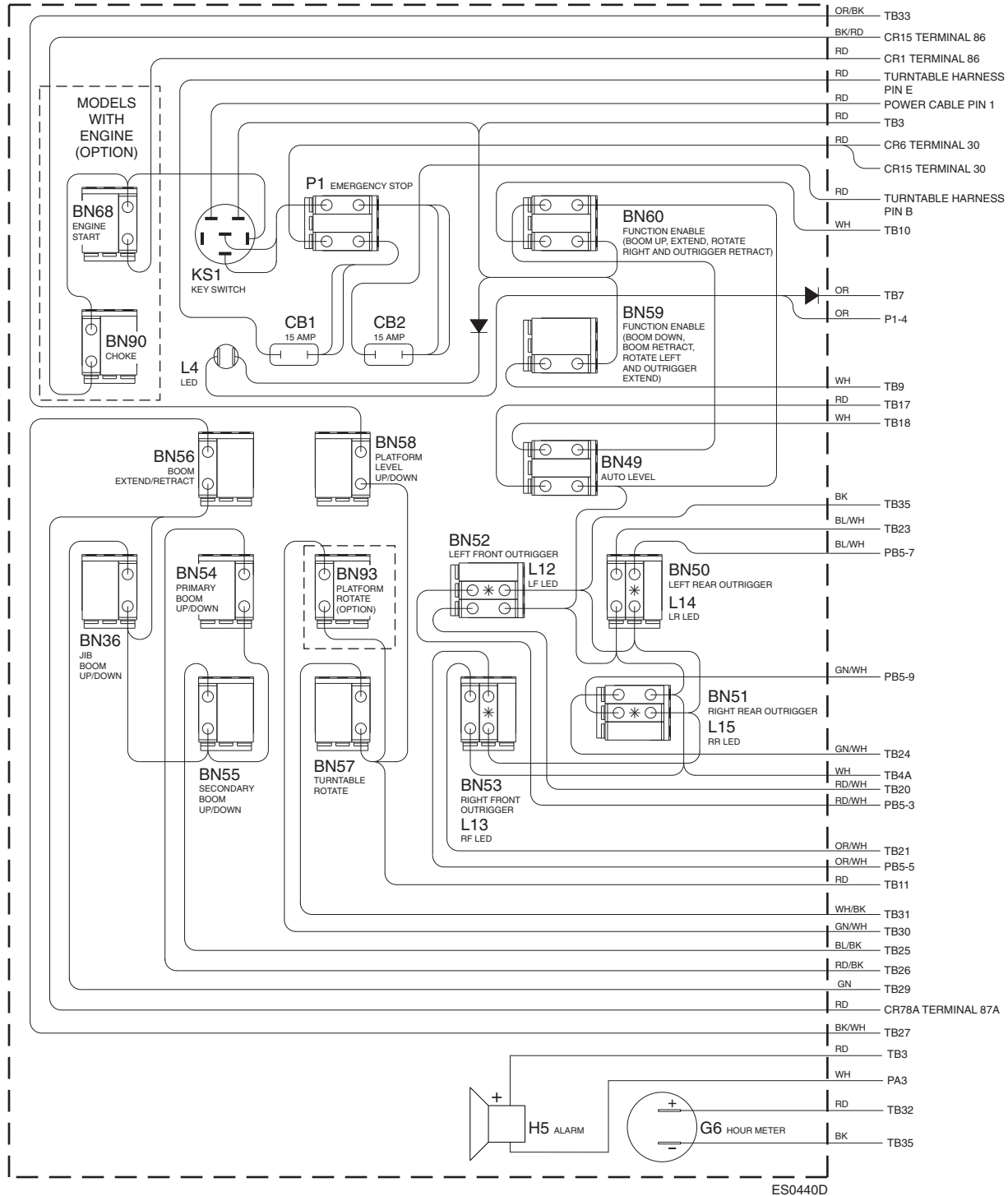

Ground Control Box Wiring Diagram - AS/CE

(from serial number TZ5010-145 to TZ5011-131)

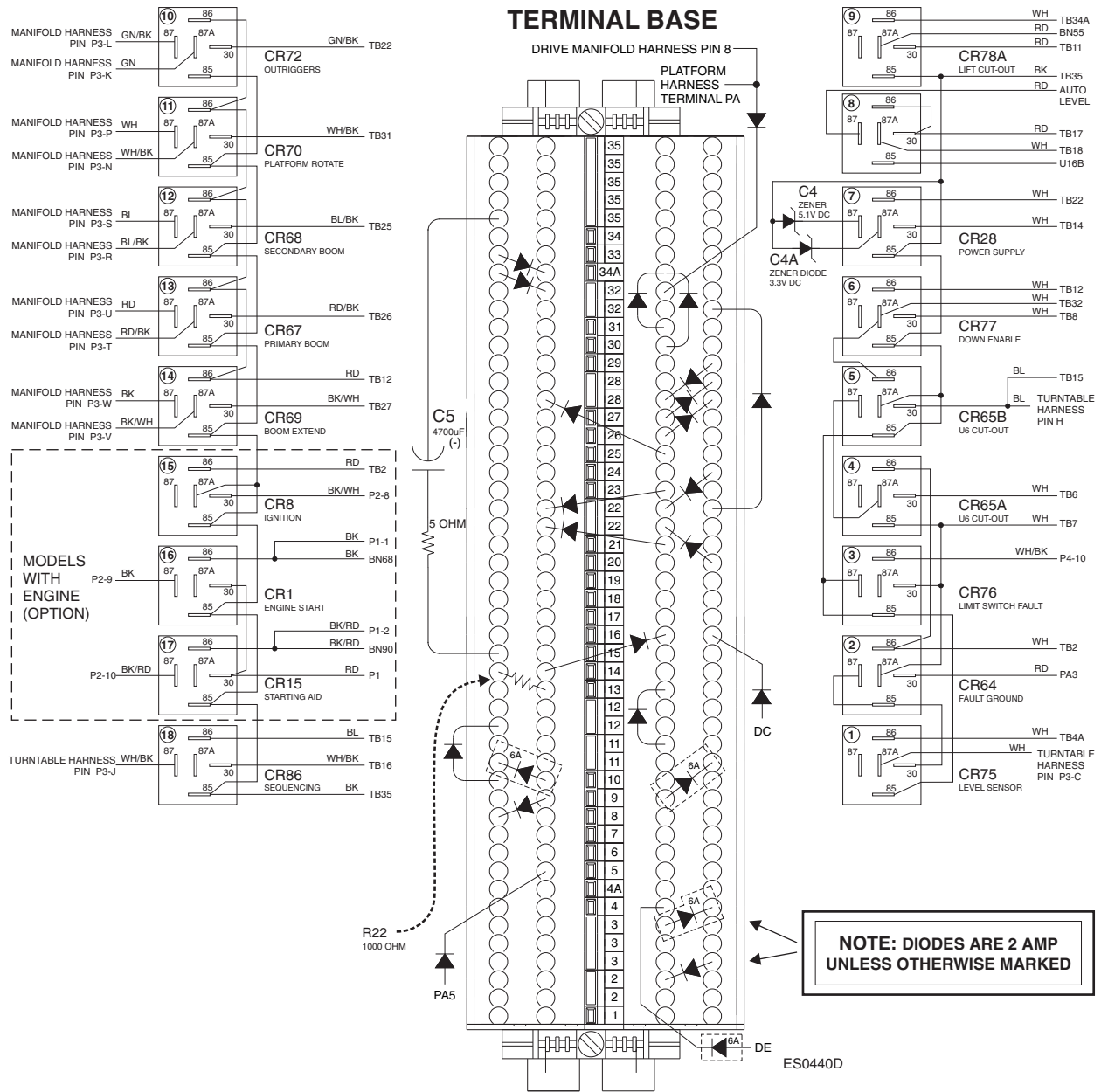

Ground Control Box Wiring Diagram - AS/CE

(from serial number TZ5011-132)

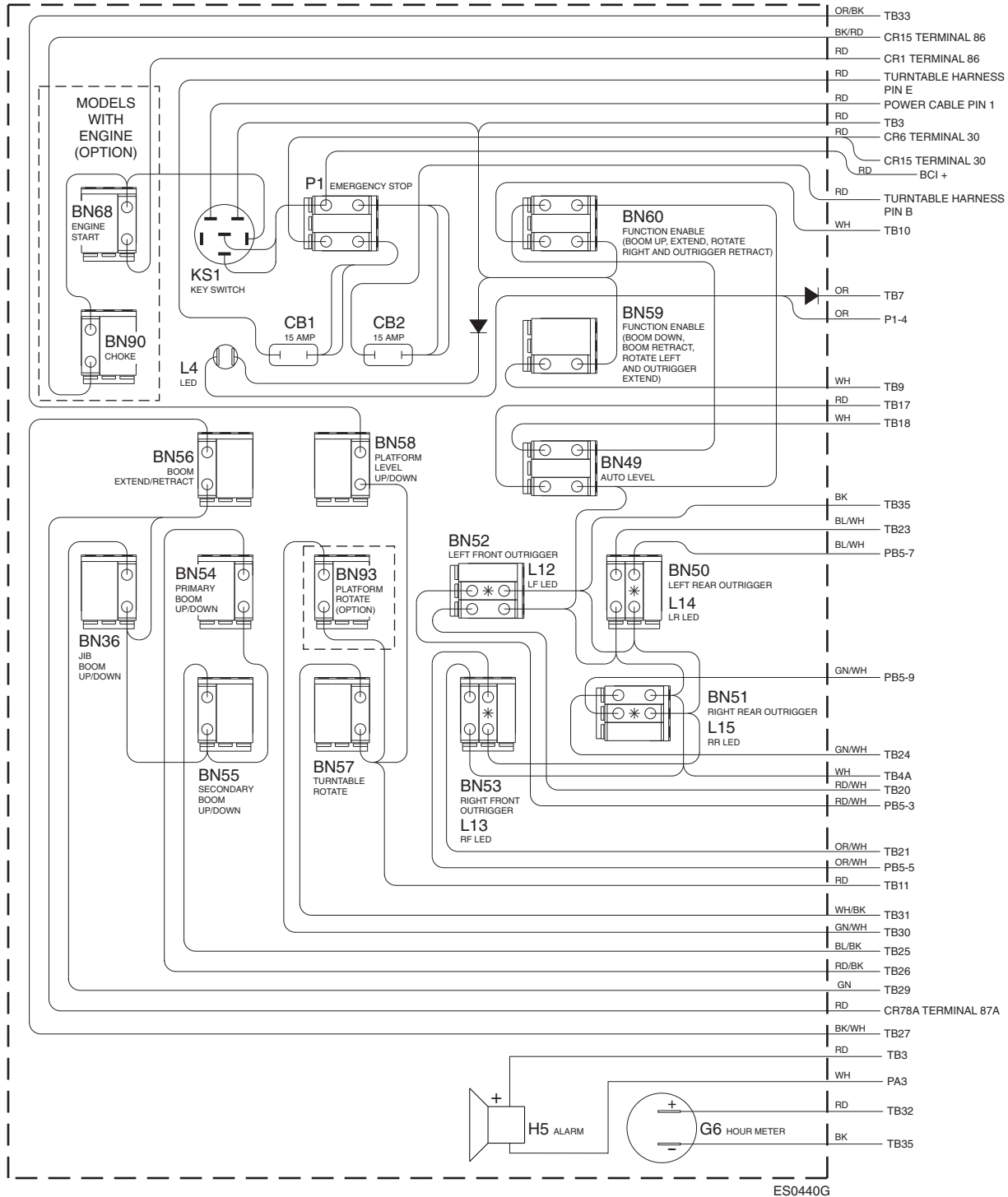

Ground Control Box Wiring Diagram - AS/CE

(from serial number TZ5011-132)

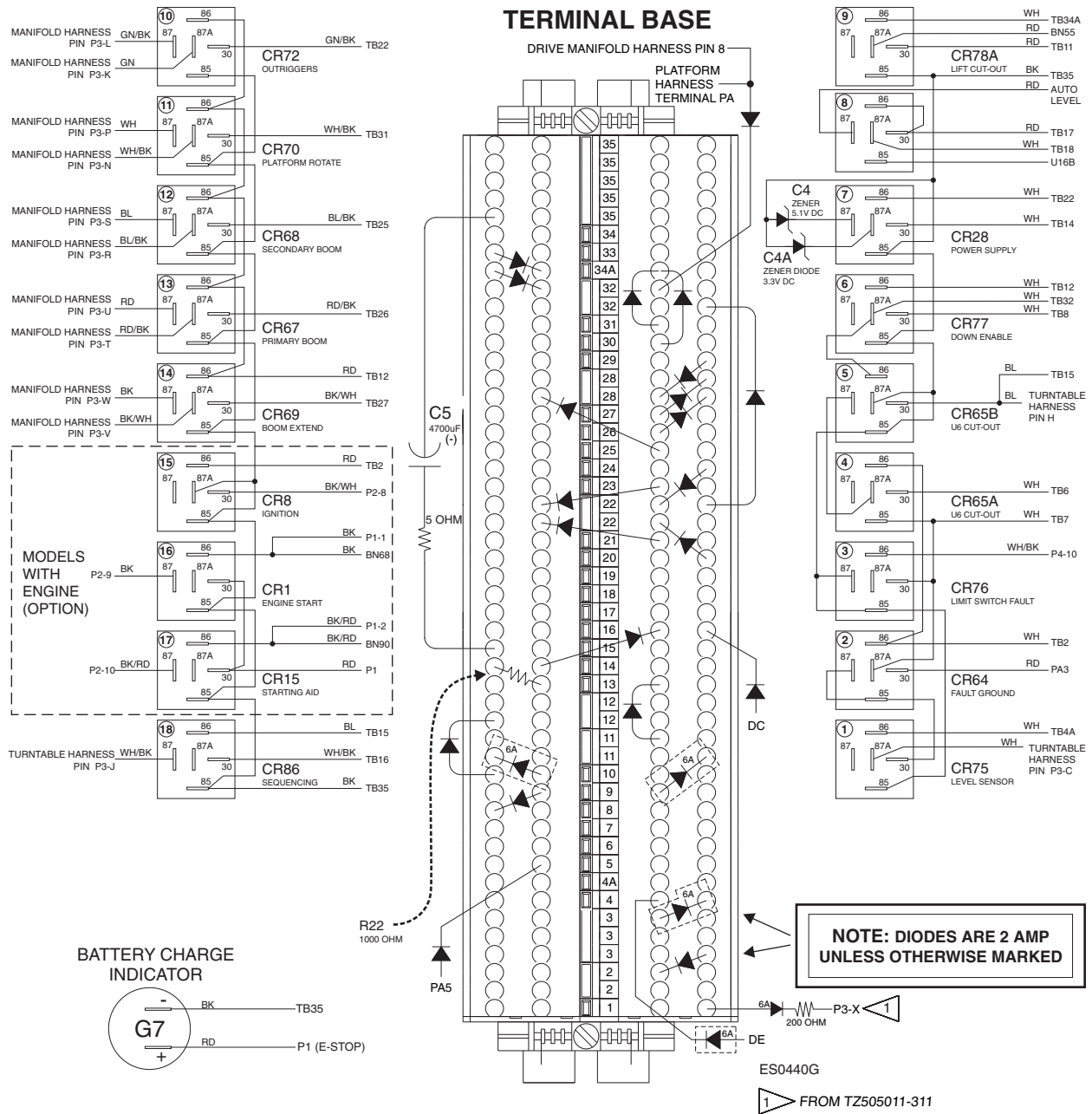

Platform Control Box Wiring Diagram - AS/CE

(to serial number TZ5004-181)

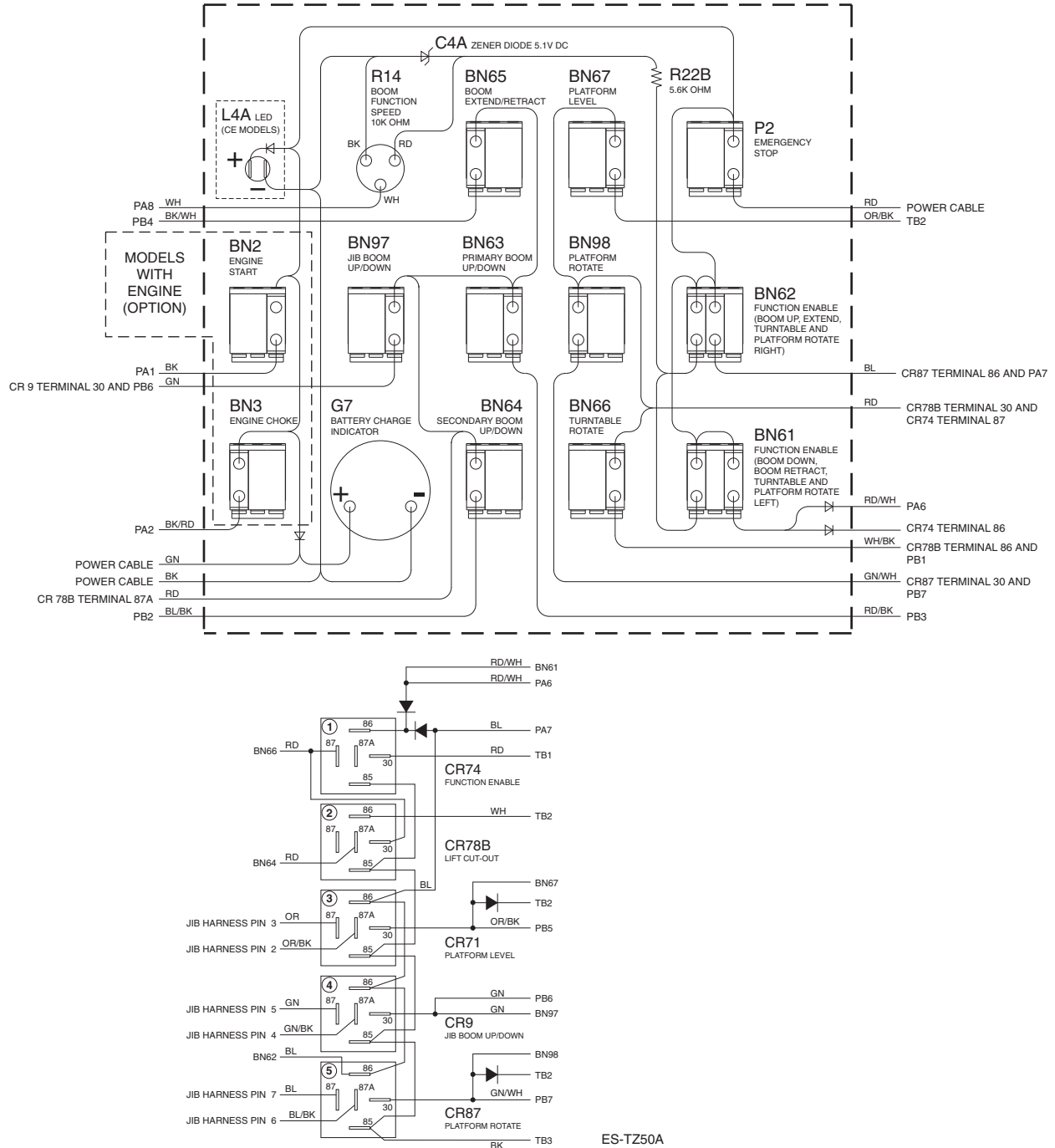

Platform Control Box Wiring Diagram - AS/CE (from serial number TZ5004-182 to TZ5005-284)

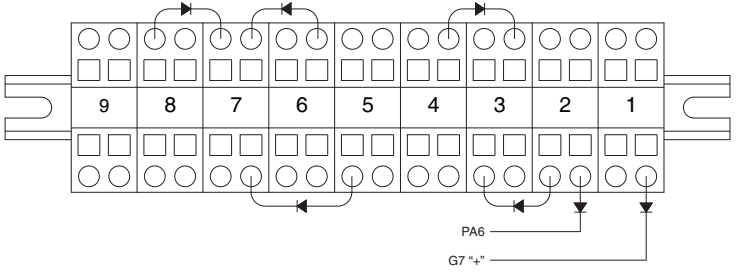
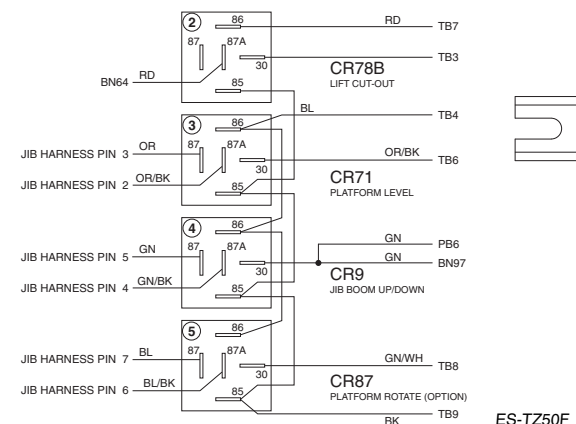
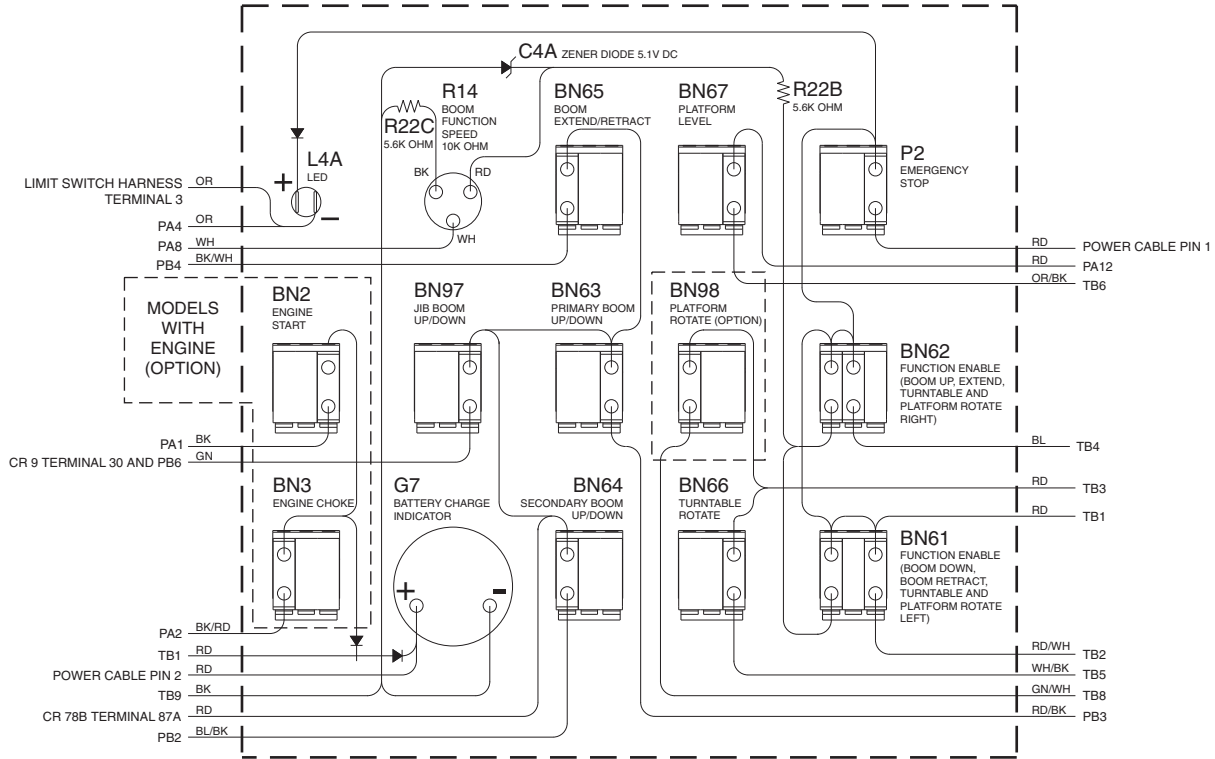

Platform Control Box Wiring Diagram - AS/CE

(from serial number TZ5005-285 to TZ5010-144)

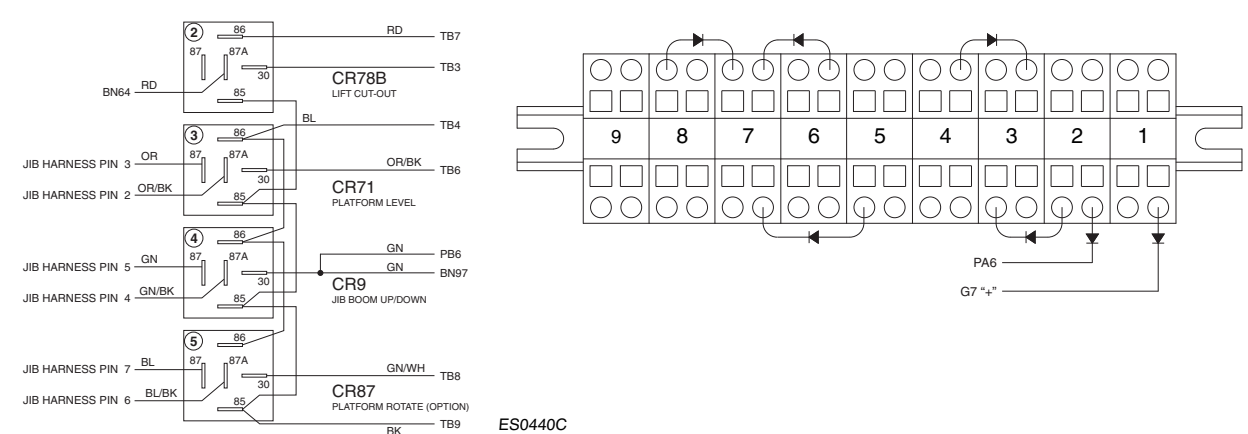
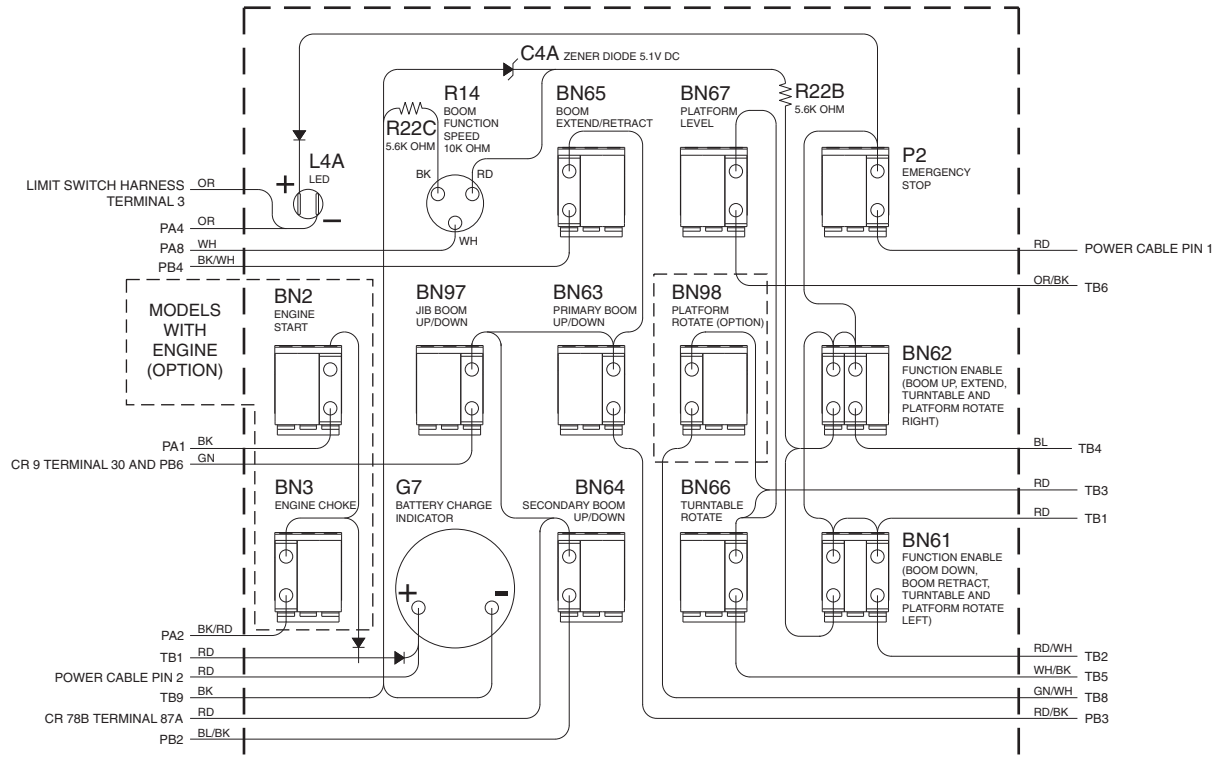

ES0440C

Platform Control Box Wiring Diagram - AS/CE

(from serial number TZ5010-145 to TZ5011-131)

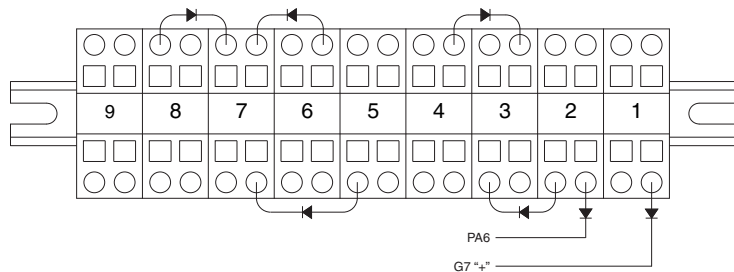
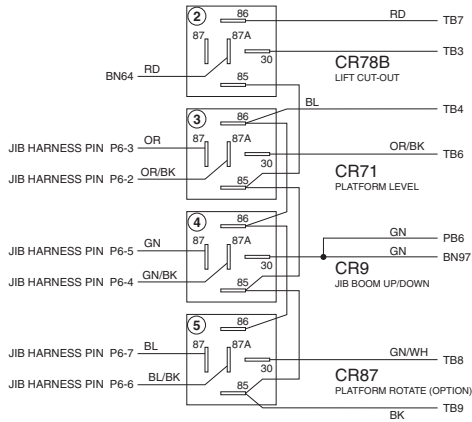
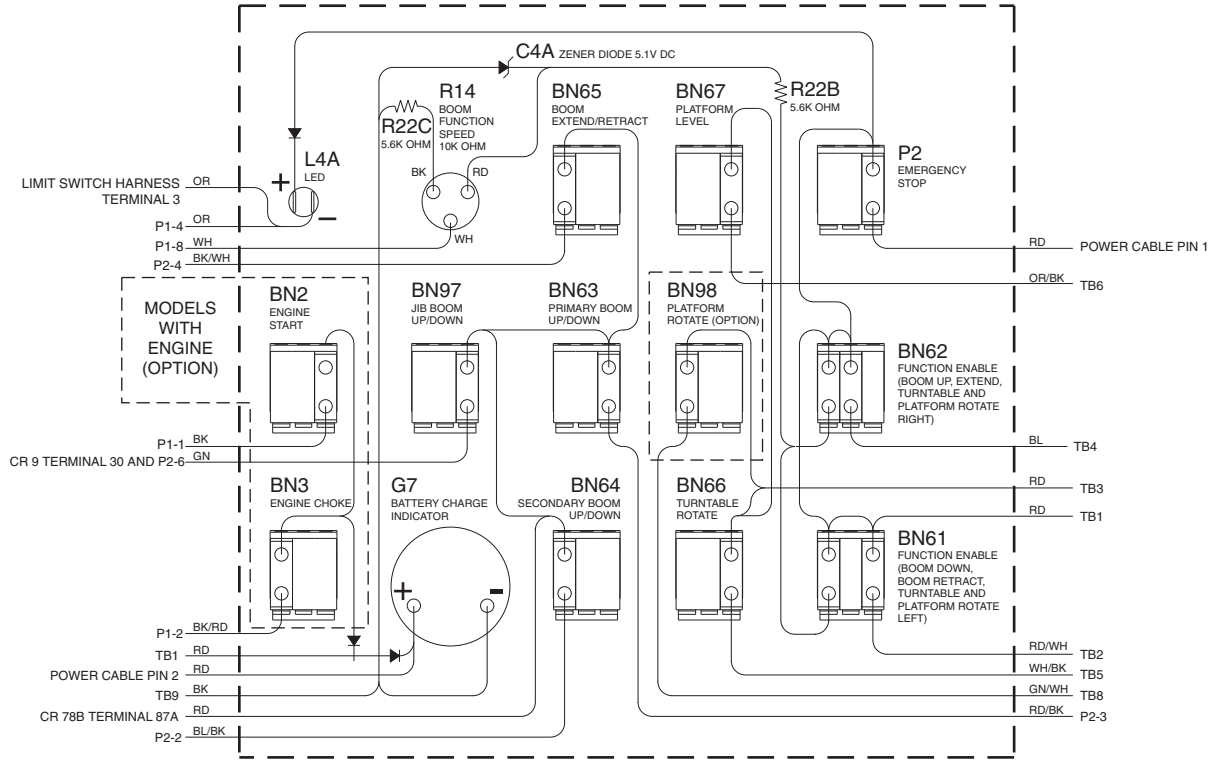

ES0440D



Platform Control Box Wiring Diagram - AS/CE

(from serial number TZ5011-132)

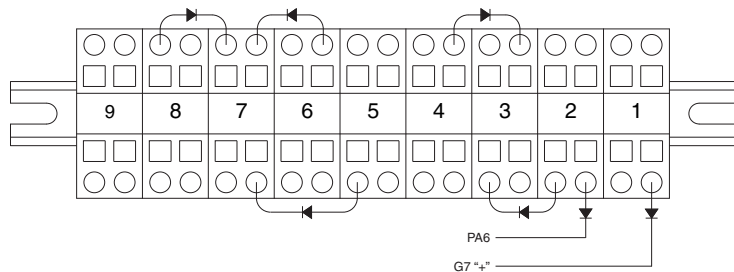
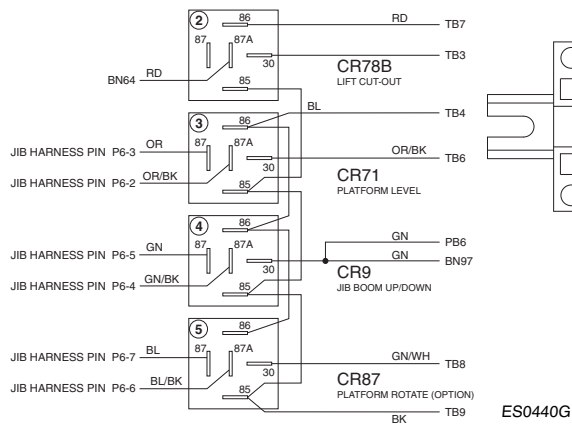
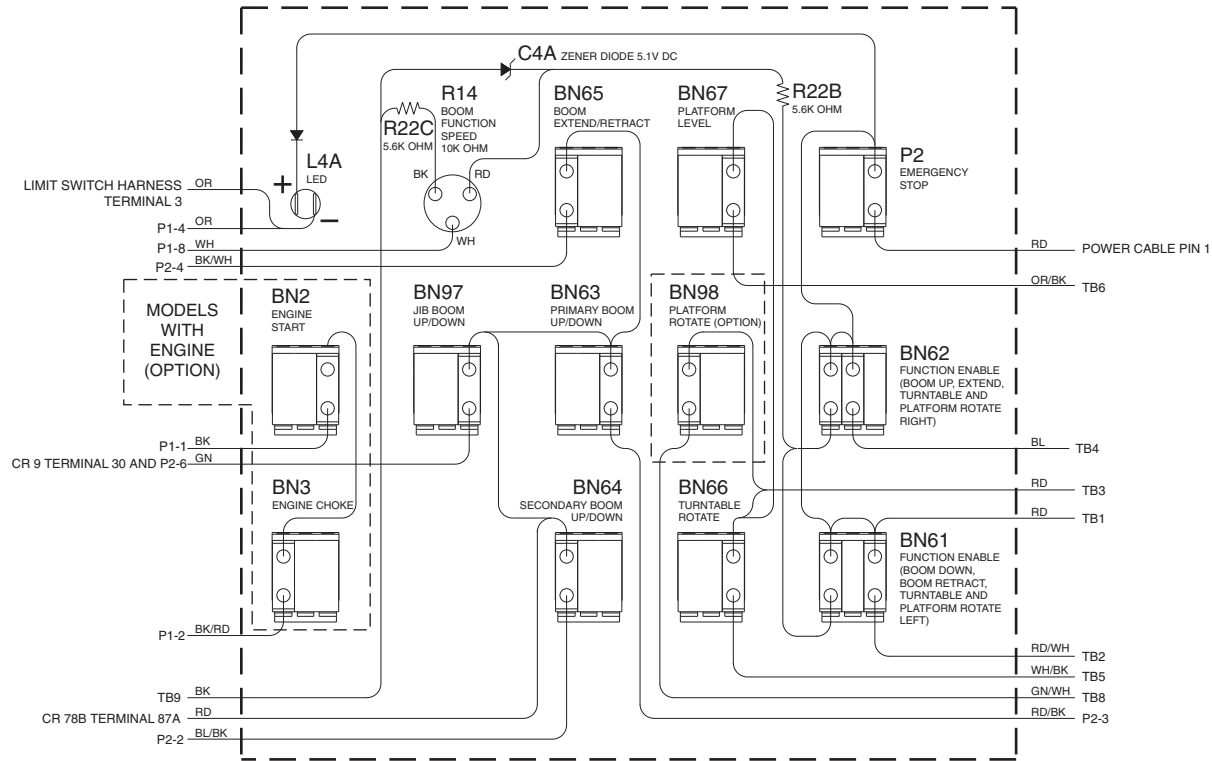

ES0440G

Drive Control Box Wiring Diagram - AS/CE (to serial number TZ5004-284)

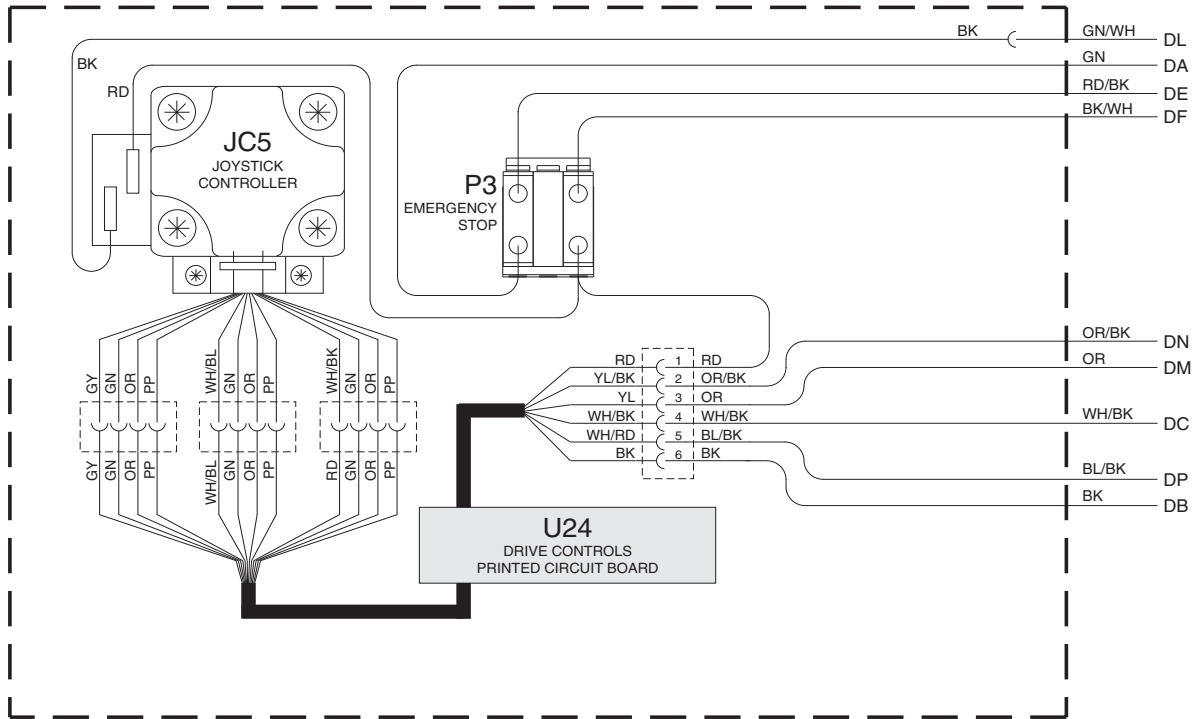

FROM TZ5005-285 REFER TO THE ELECTRICAL SCHEMATIC
FOR YOUR MODEL AND SERIAL NUMBER.

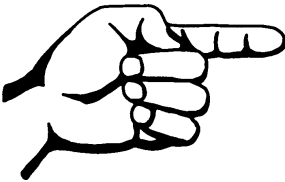

This page intentionally left blank.

**Electrical Schematic - ANSI/CSA
(to serial number TZ5004-181)**

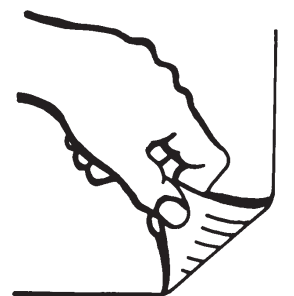
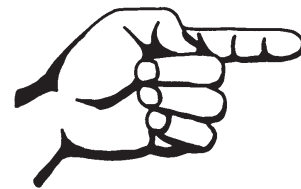

Electrical Schematic - ANSI/CSA, 1 of 3 (to serial number TZ5004-181)

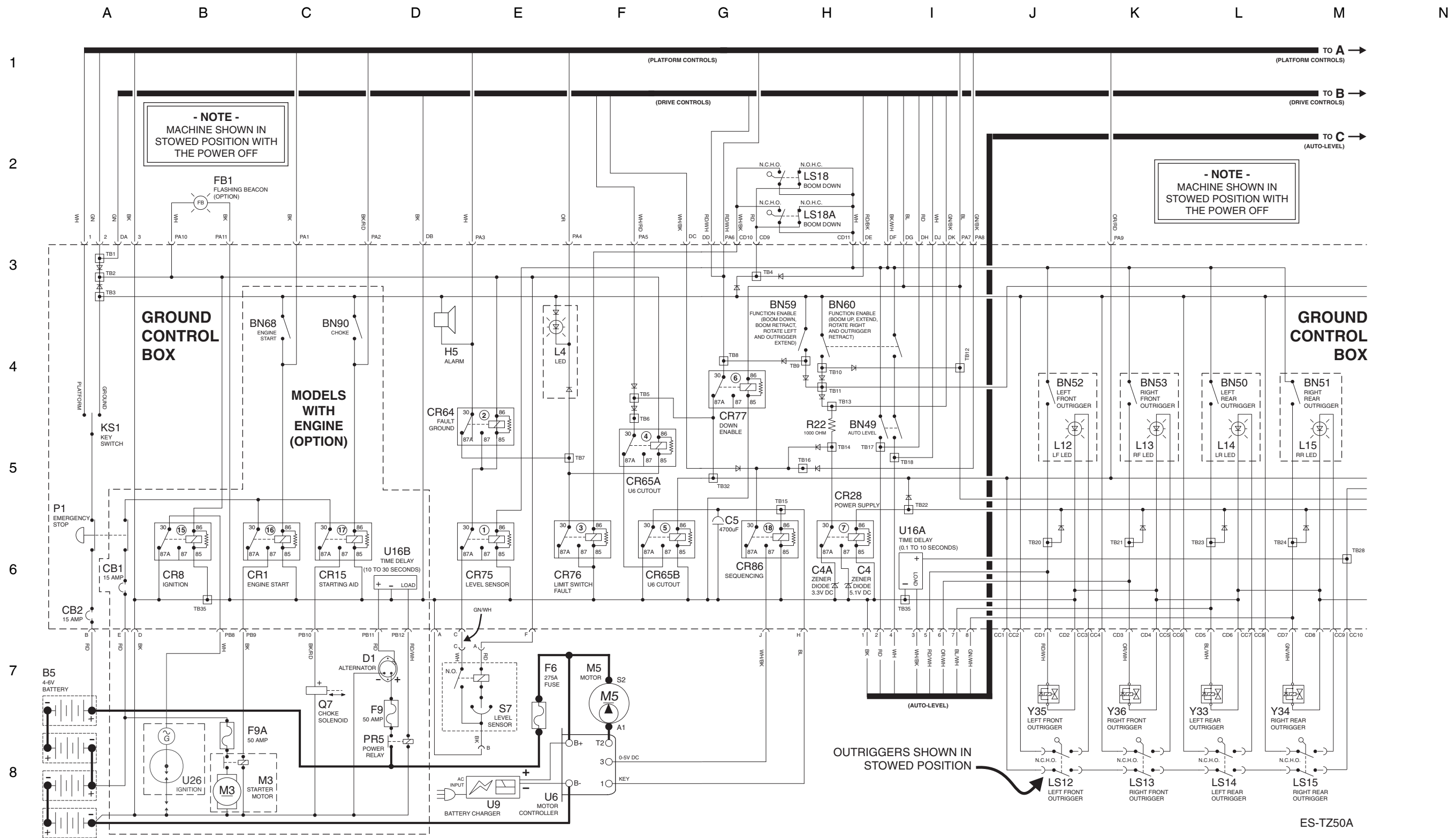

ES-TZ50A

Electrical Schematic - ANSI/CSA, 2 of 3 (to serial number TZ5004-181)

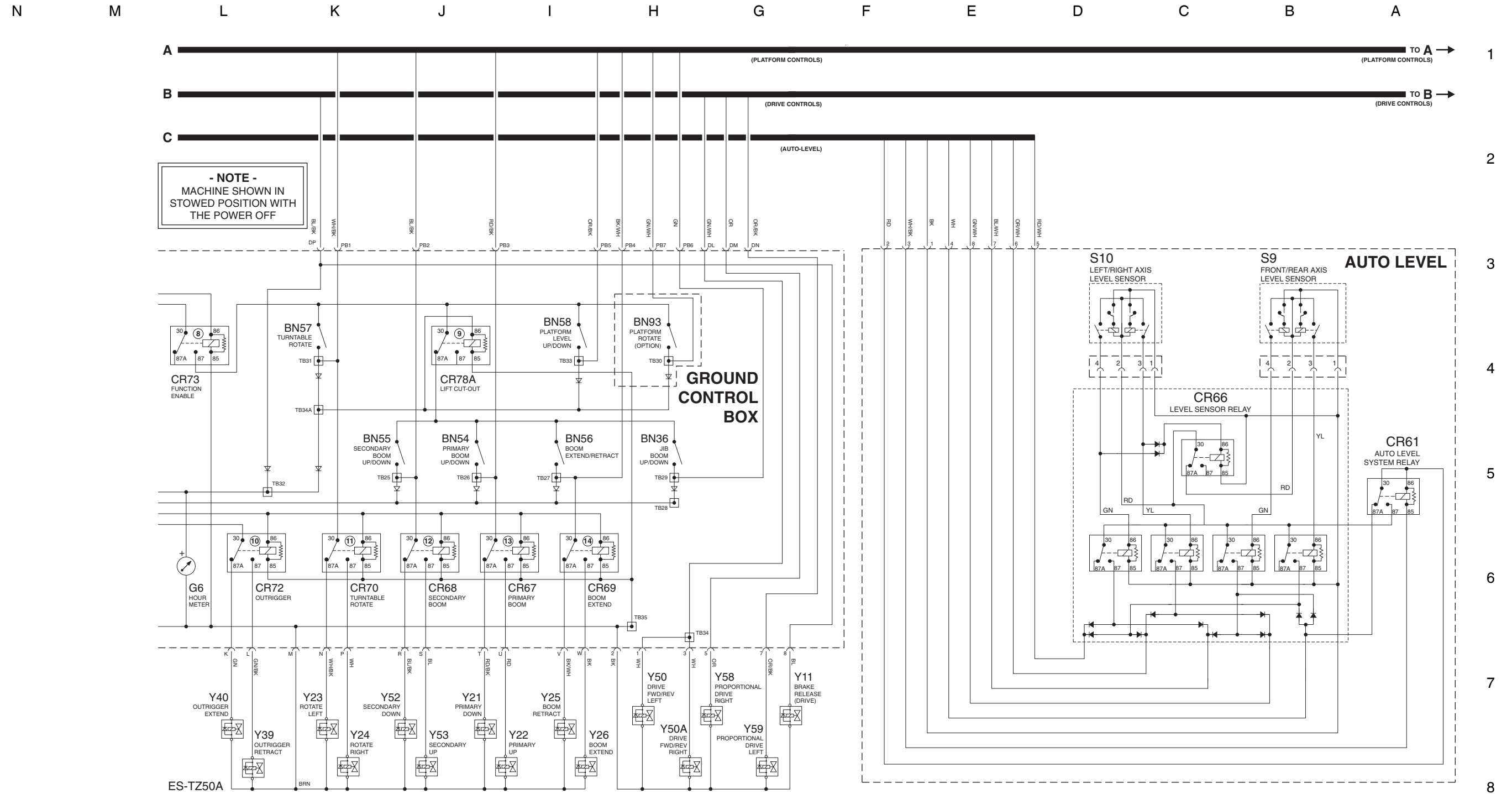

**Electrical Schematic - ANSI/CSA
(to serial number TZ5004-181)**

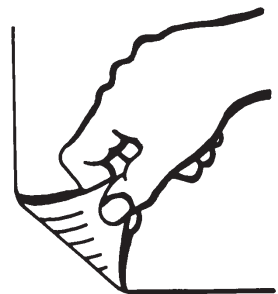

Electrical Schematic - ANSI/CSA, 3 of 3 (to serial number TZ5004-181)

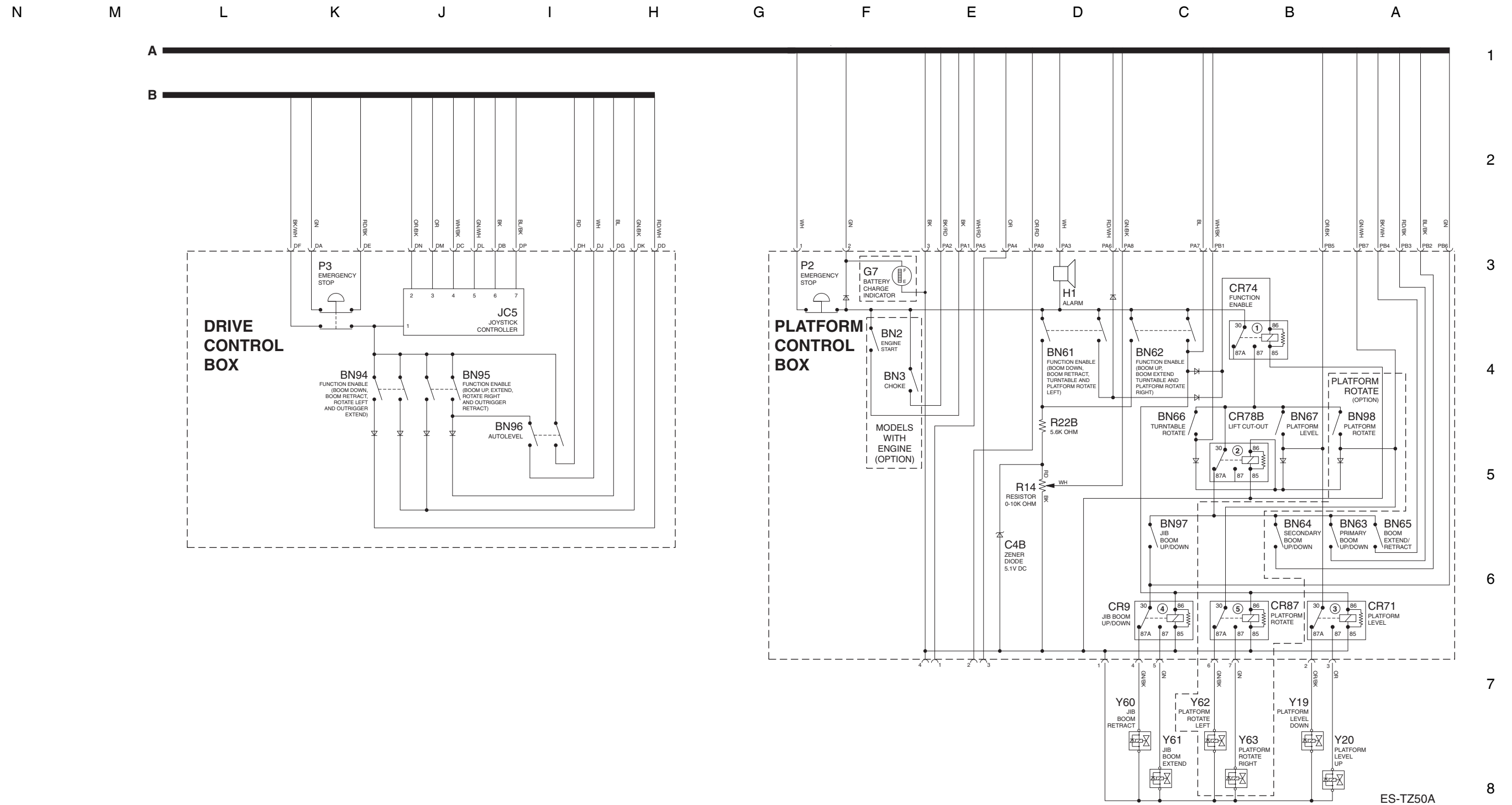

ES-TZ50A



**Electrical Schematic - ANSI/CSA
(to serial number TZ5004-181)**

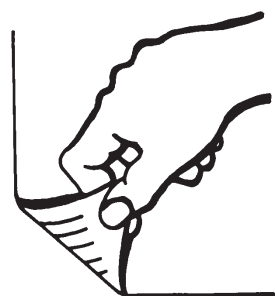

Electrical Schematic - ANSI/CSA
(from serial number TZ5004-182 to TZ5005-210)

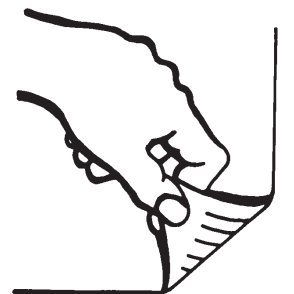
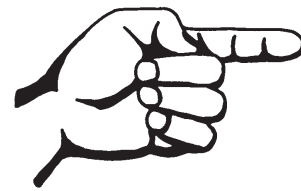

Electrical Schematic - ANSI/CSA, 1 of 3 (from serial number TZ5004-182 to TZ5005-210)

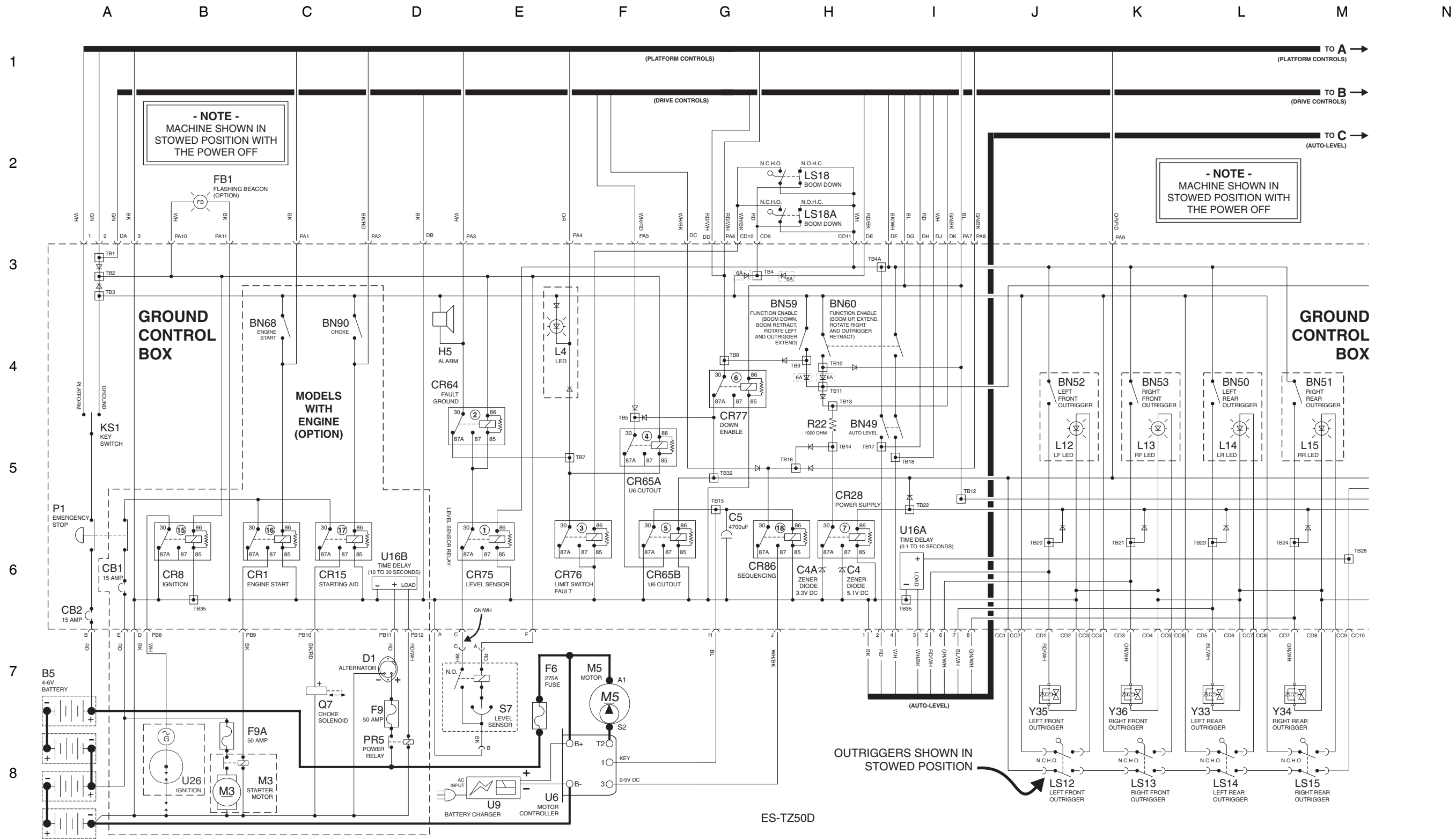

ES-TZ50D

Electrical Schematic - ANSI/CSA, 2 of 3 (from serial number TZ5004-182 to TZ5005-210)

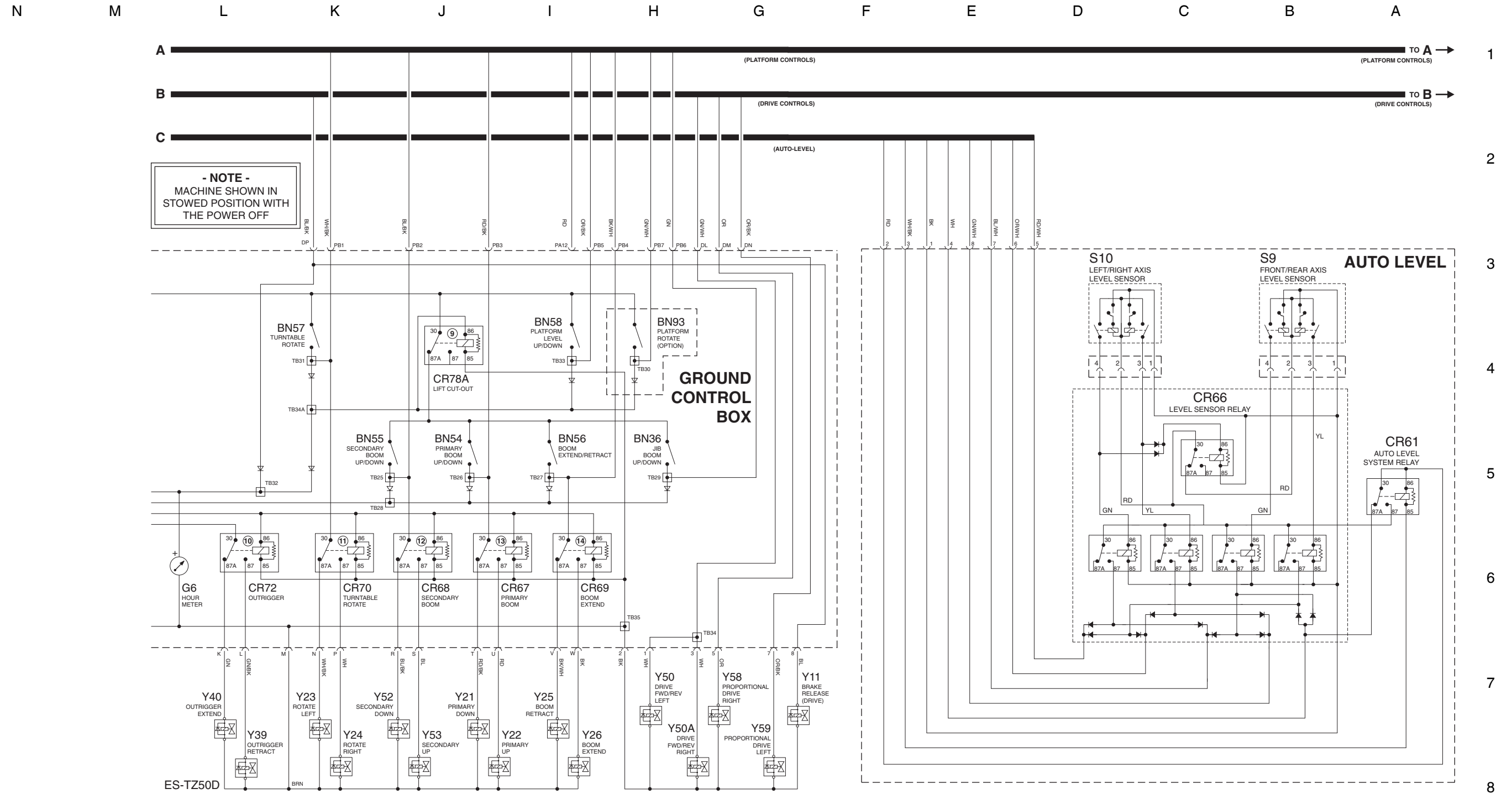

Electrical Schematic - ANSI/CSA
(from serial number TZ5004-182 to TZ5005-210)

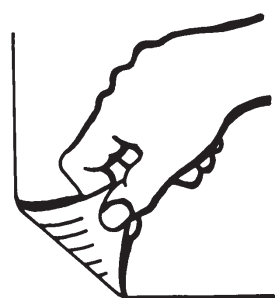

Electrical Schematic - ANSI/CSA, 3 of 3 (from serial number TZ5004-182 to TZ5005-210)

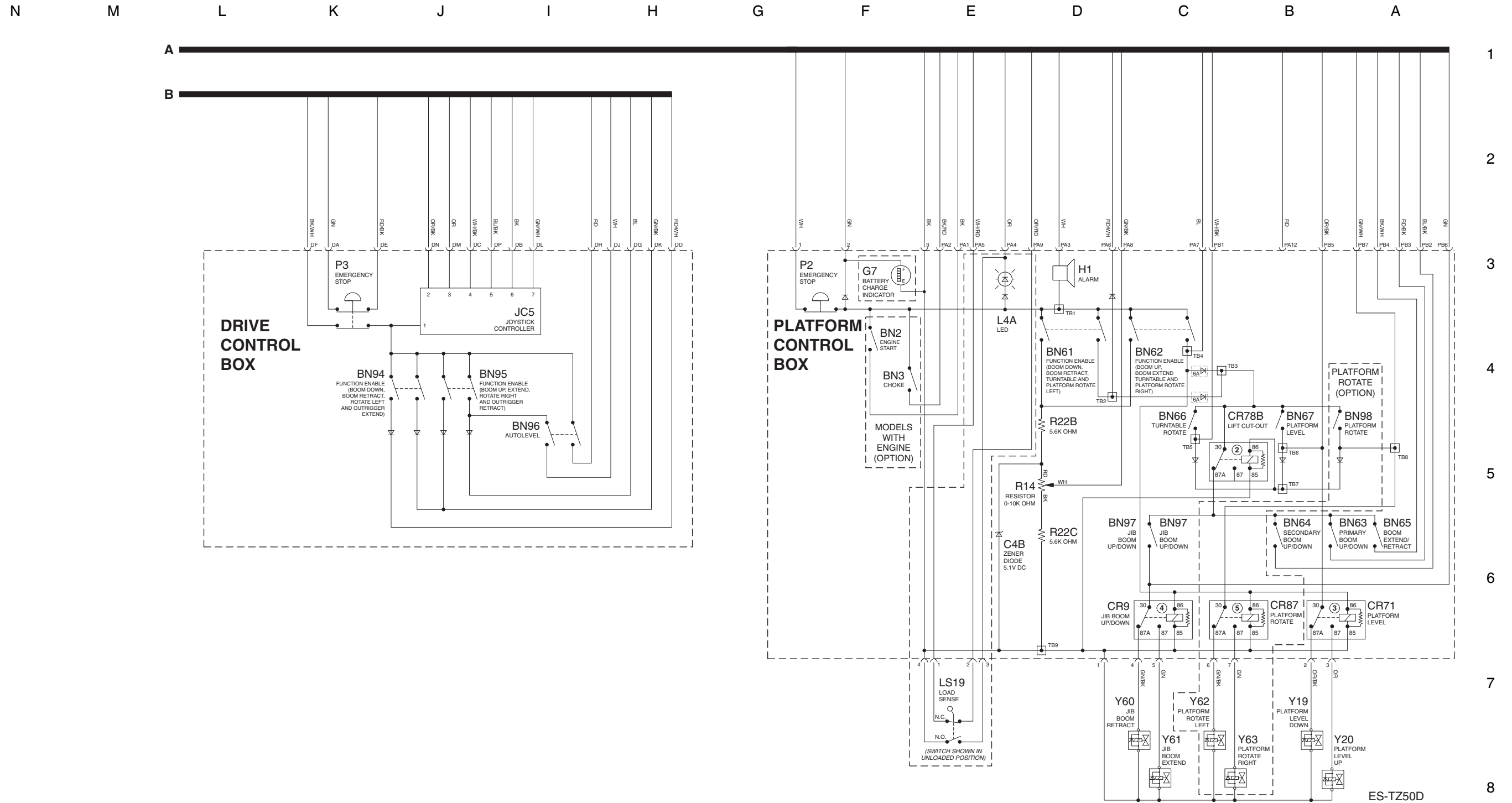

Electrical Schematic - ANSI/CSA
(from serial number TZ5004-182 to TZ5005-210)

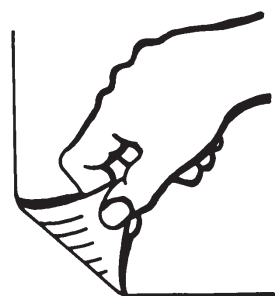

Electrical Schematic - ANSI/CSA
(from serial number TZ5005-211 to TZ5005-284)

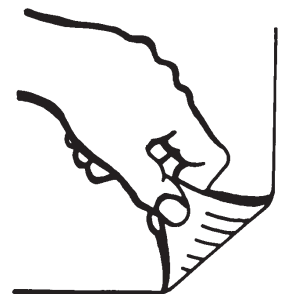
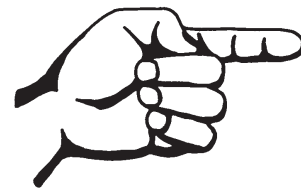

Electrical Schematic - ANSI/CSA, 1 of 3 (from serial number TZ5005-211 to TZ5005-284)

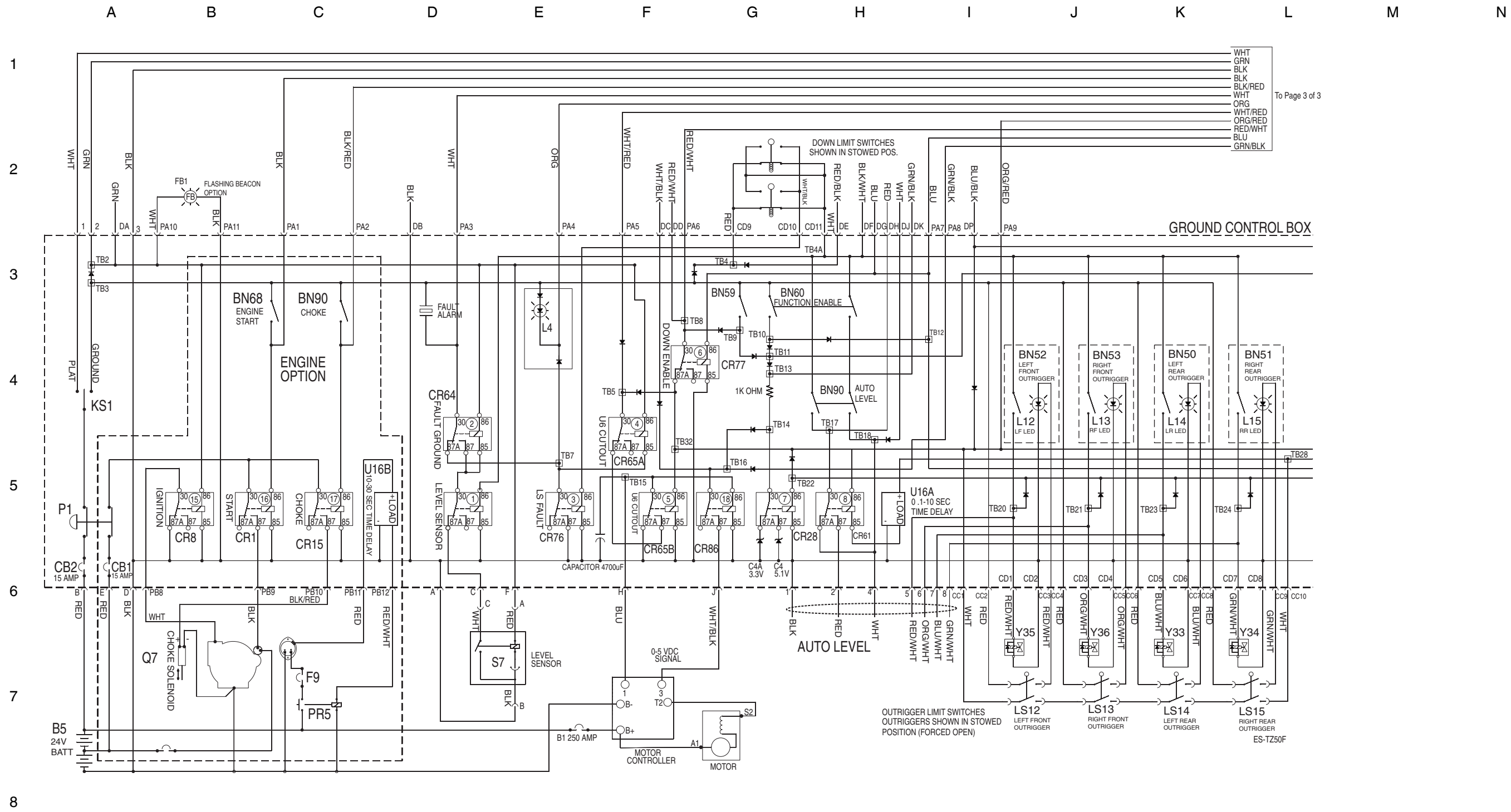

To Page 3 of 3

Electrical Schematic - ANSI/CSA, 2 of 3 (from serial number TZ5005-211 to TZ5005-284)

N M L K J I H G F E D C B A

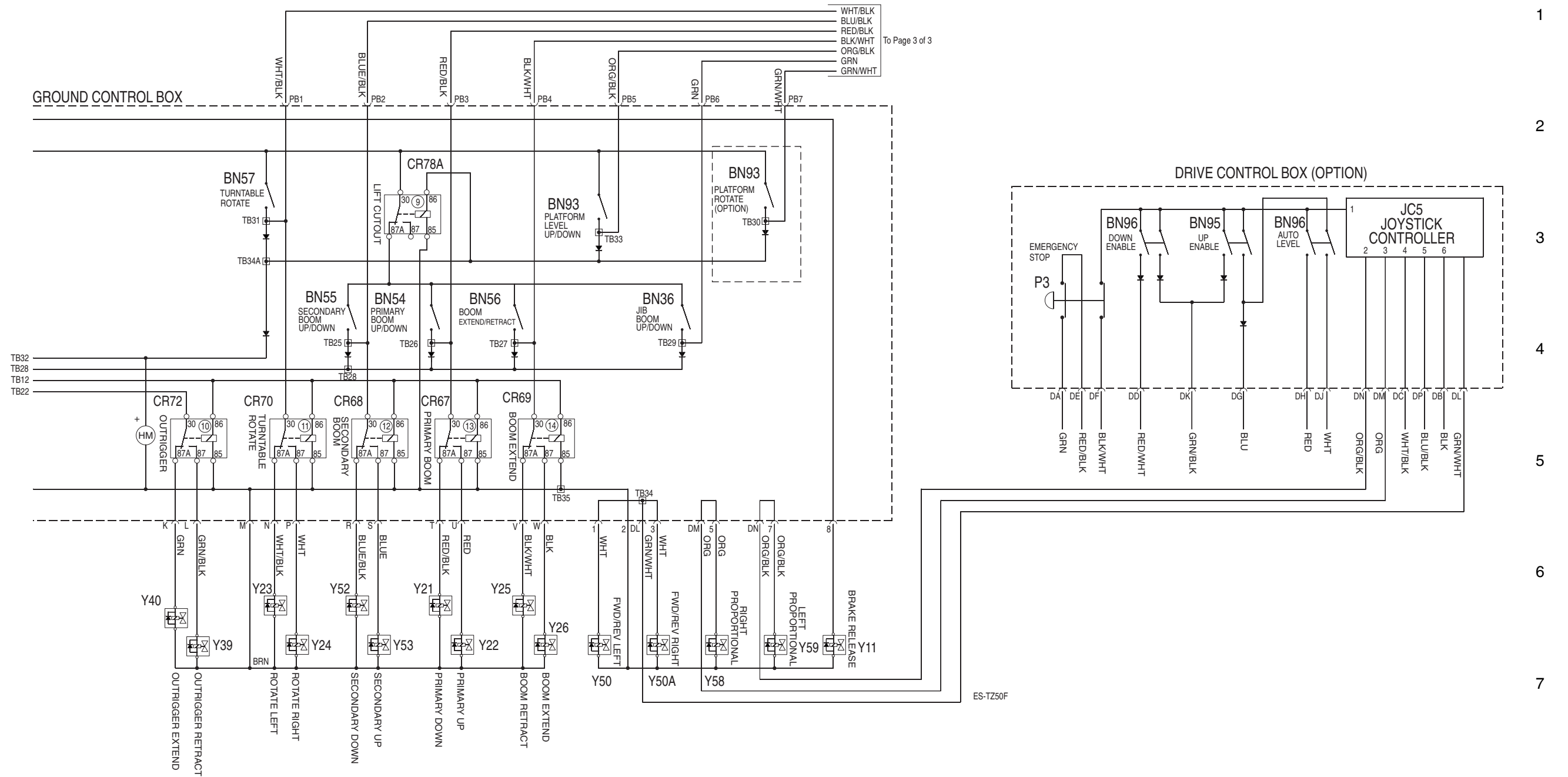

Electrical Schematic - ANSI/CSA
(from serial number TZ5005-211 to TZ5005-284)

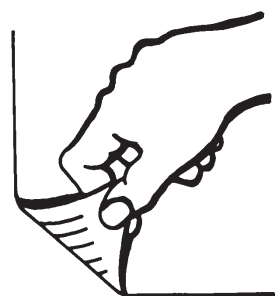

Electrical Schematic - ANSI/CSA, 3 of 3 (from serial number TZ5005-211 to TZ5005-284)

N M L K J I H G F E D C B A

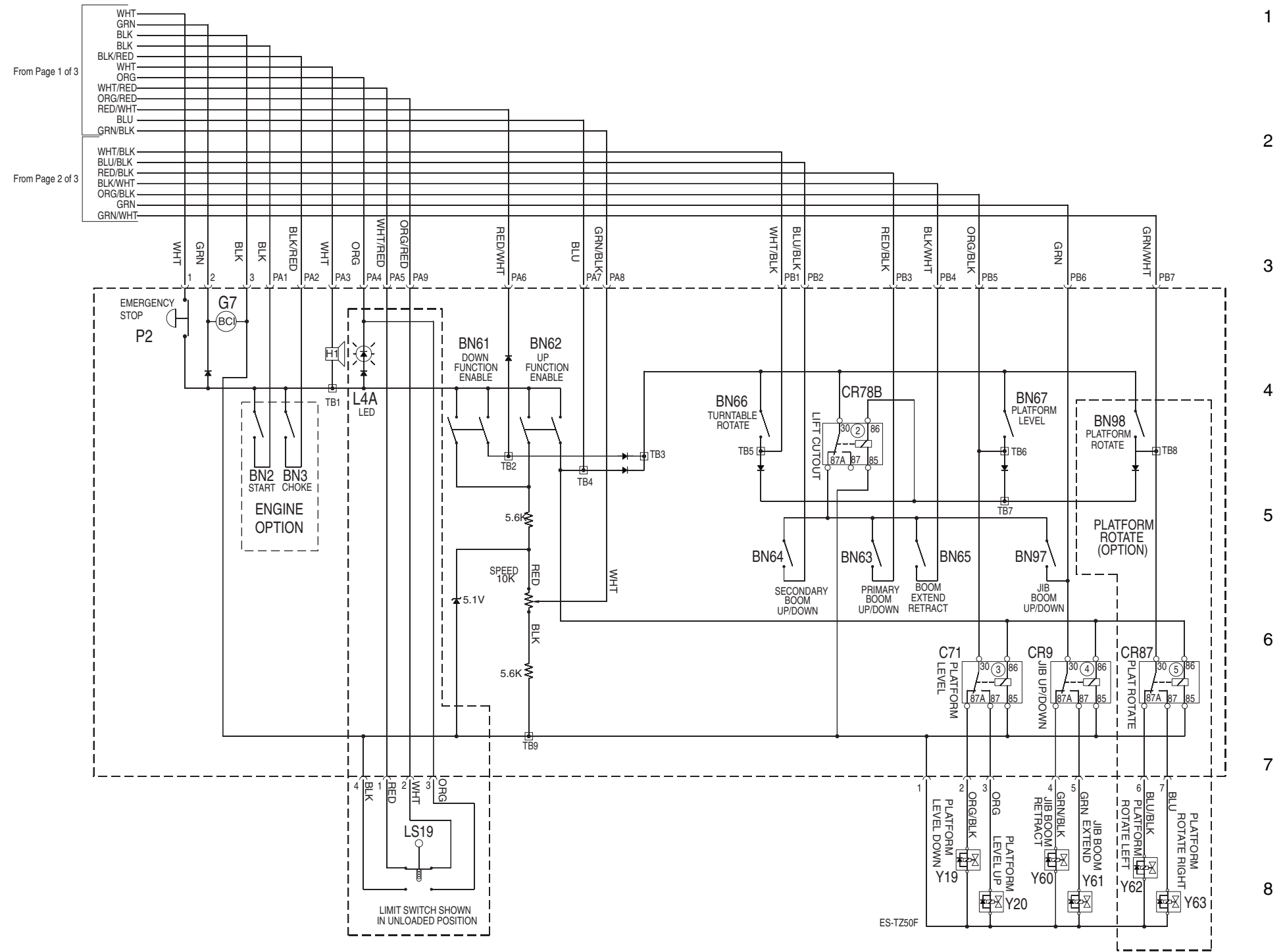

Electrical Schematic - ANSI/CSA
(from serial number TZ50005-211 to TZ5005-284)

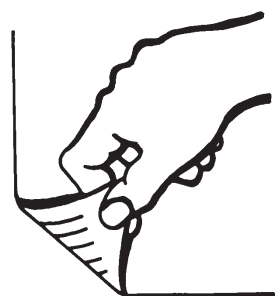

**Electrical Schematic - ANSI/CSA
(from serial number TZ5005-285 to TZ5010-144)**

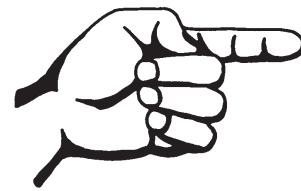

Electrical Schematic - ANSI/CSA, 1 of 3 (from serial number TZ5005-285 to TZ5010-144)

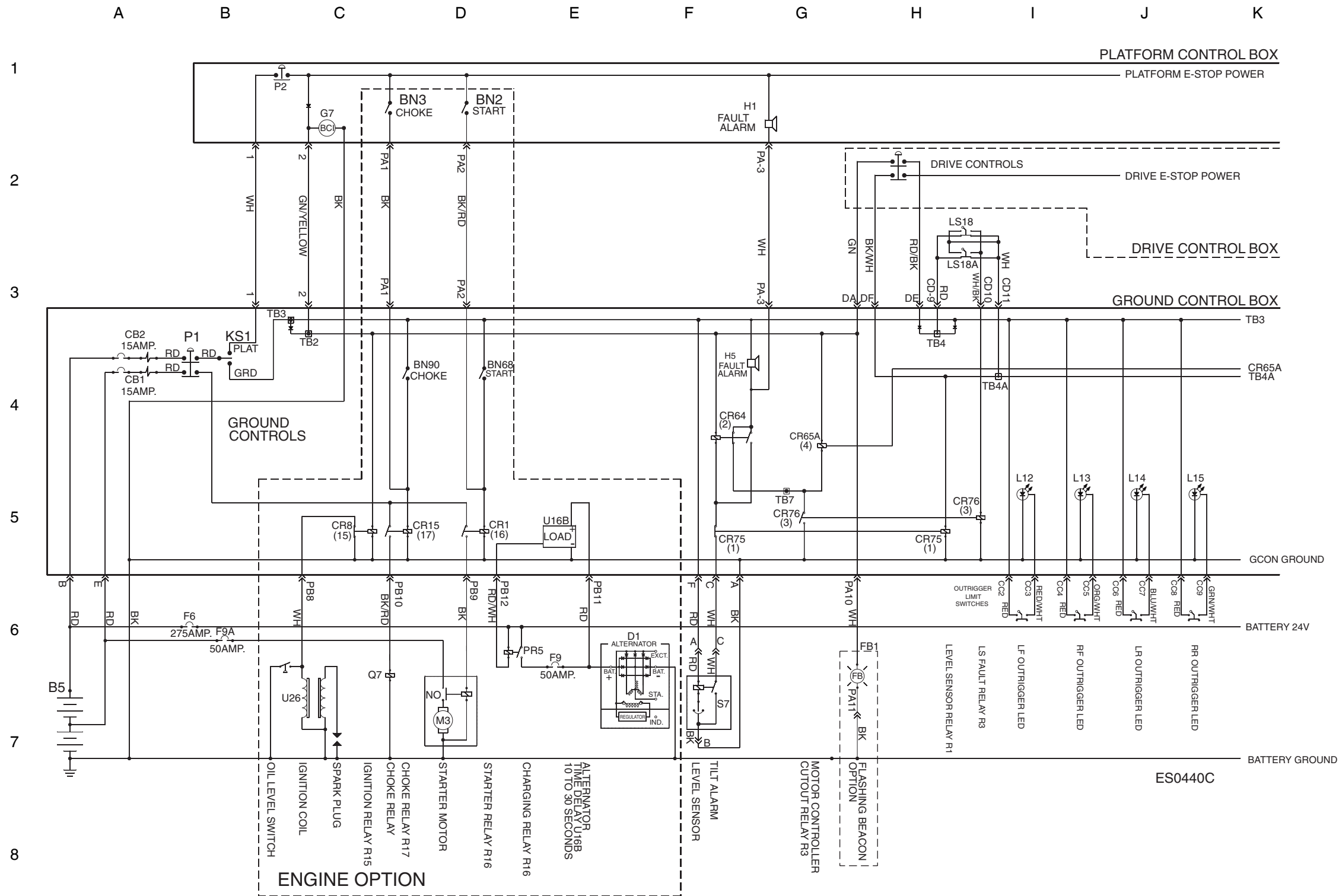

Electrical Schematic - ANSI/CSA, 2 of 3 (from serial number TZ5005-285 to TZ5010-144)

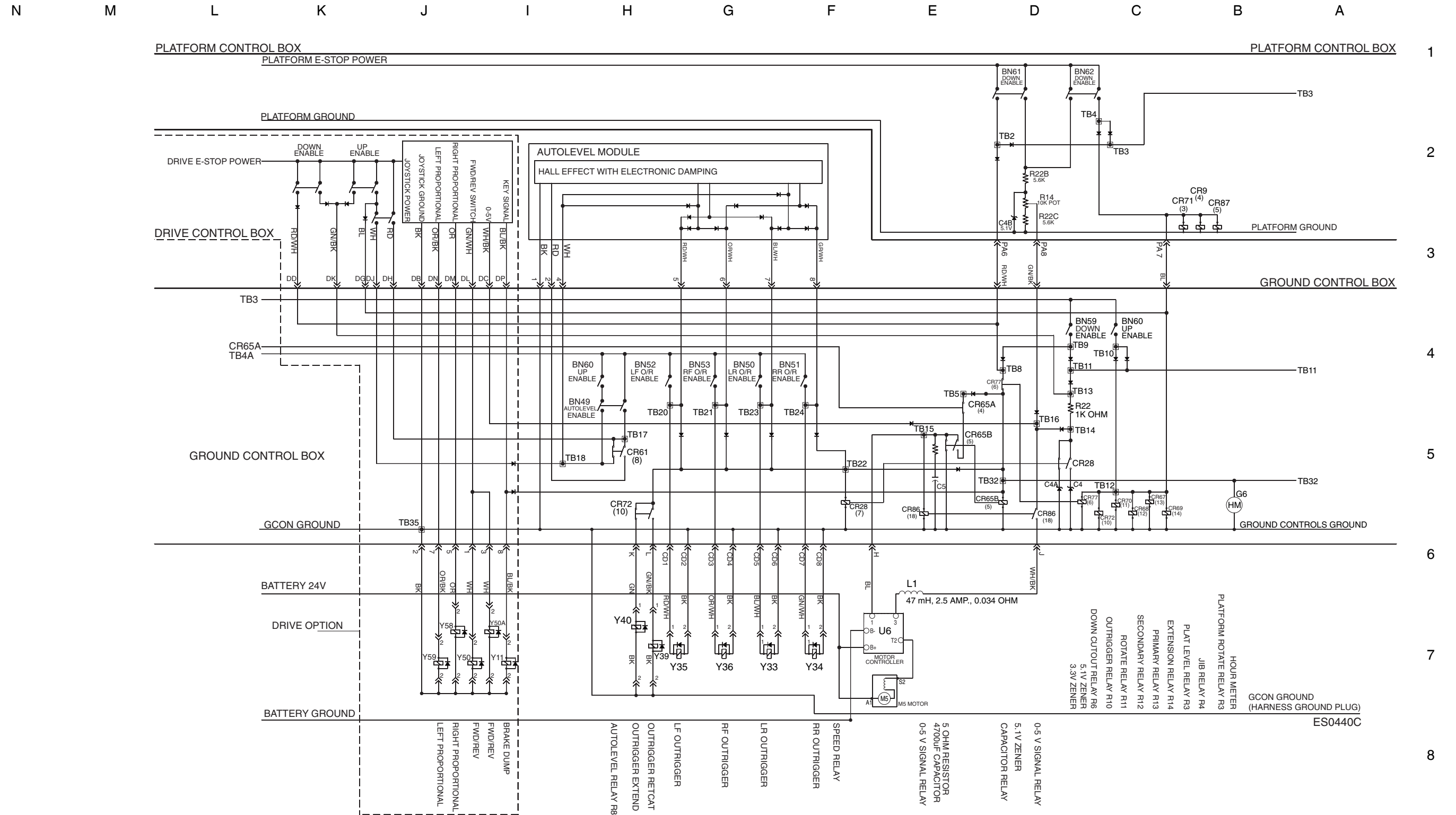

Electrical Schematic - ANSI/CSA
(from serial number TZ5005-285 to TZ5010-144)

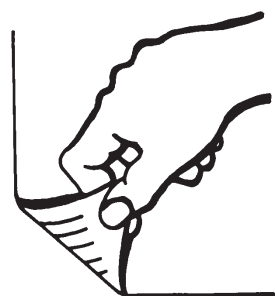

Electrical Schematic - ANSI/CSA, 3 of 3 (from serial number TZ5005-285 to TZ5010-144)

N M L K J I H G F E D C B A

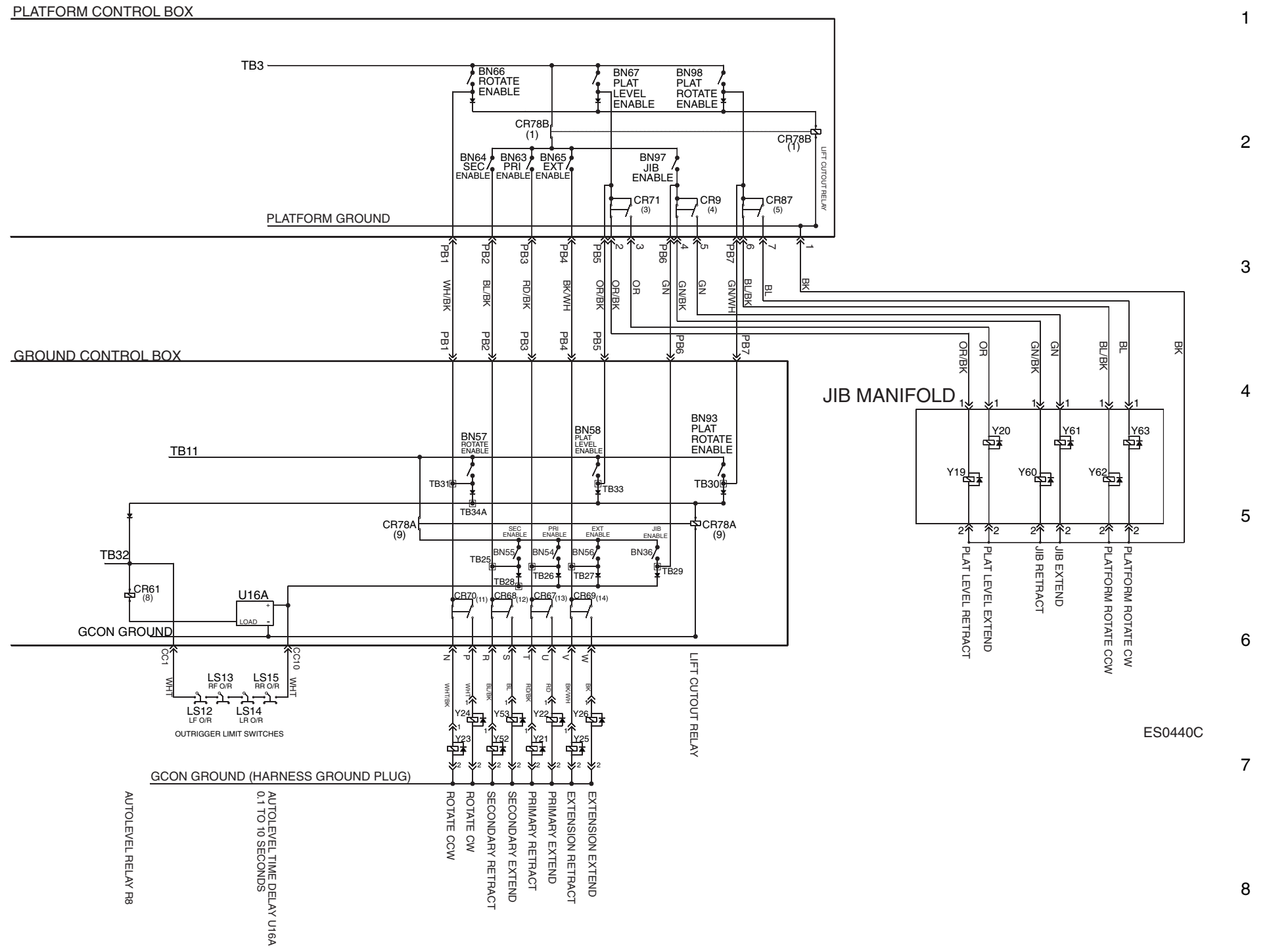

ES0440C

Electrical Schematic - ANSI/CSA
(from serial number TZ5005-285 to TZ5010-144)

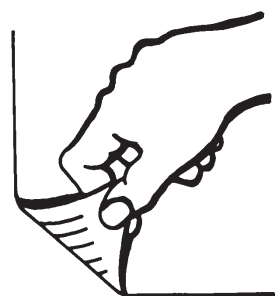

**Electrical Schematic - ANSI/CSA
(from serial number TZ5010-145 to TZ5011-131)**

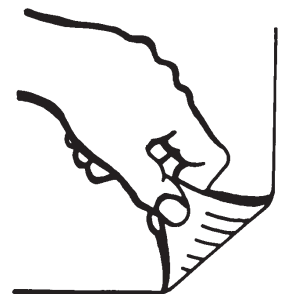
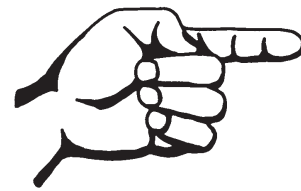

Electrical Schematic - ANSI/CSA, 1 of 3 (from serial number TZ5010-145 to TZ5011-131)

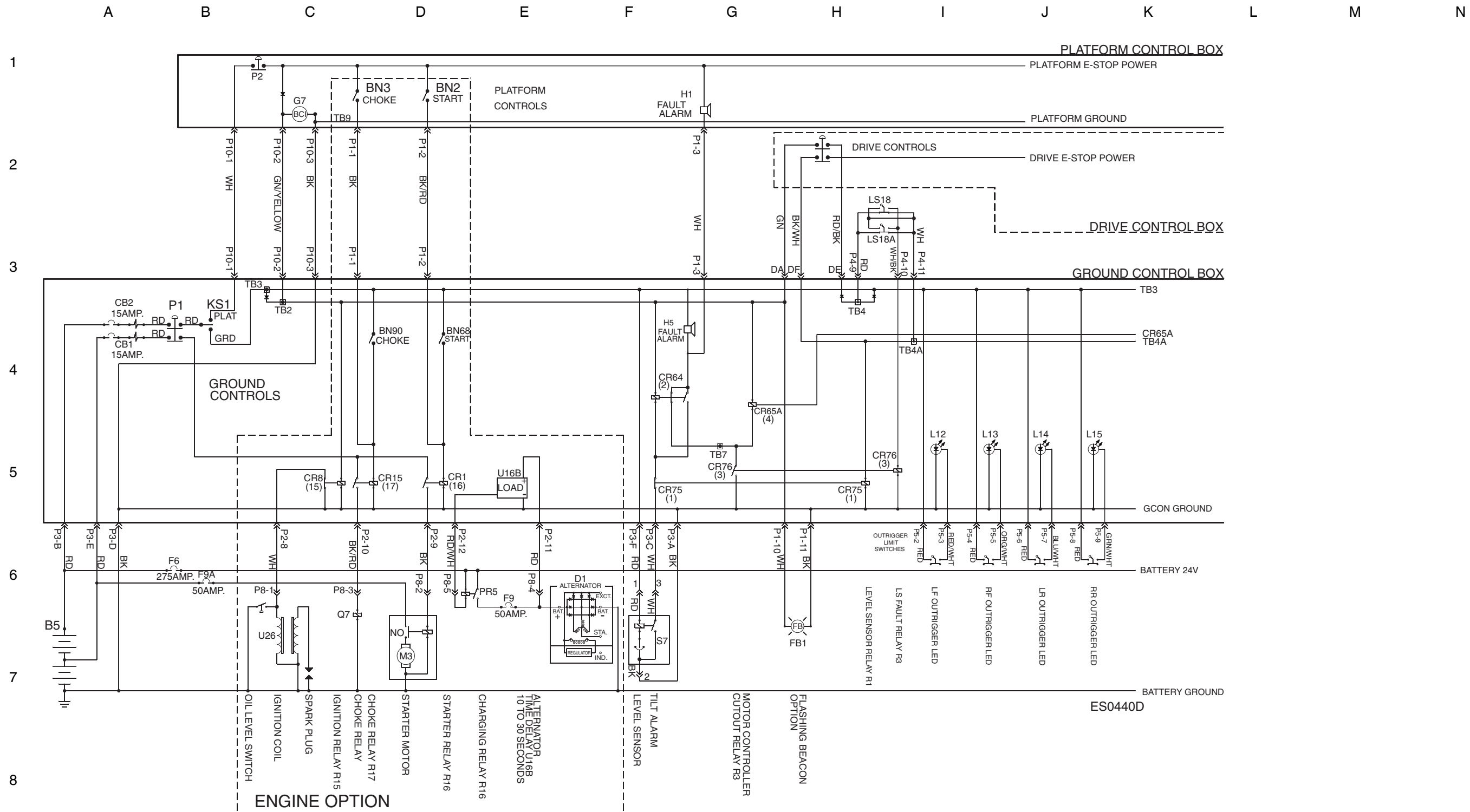

Electrical Schematic - ANSI/CSA, 2 of 3 (from serial number TZ5010-145 to TZ5011-131)

N M L K J I H G F E D C B A

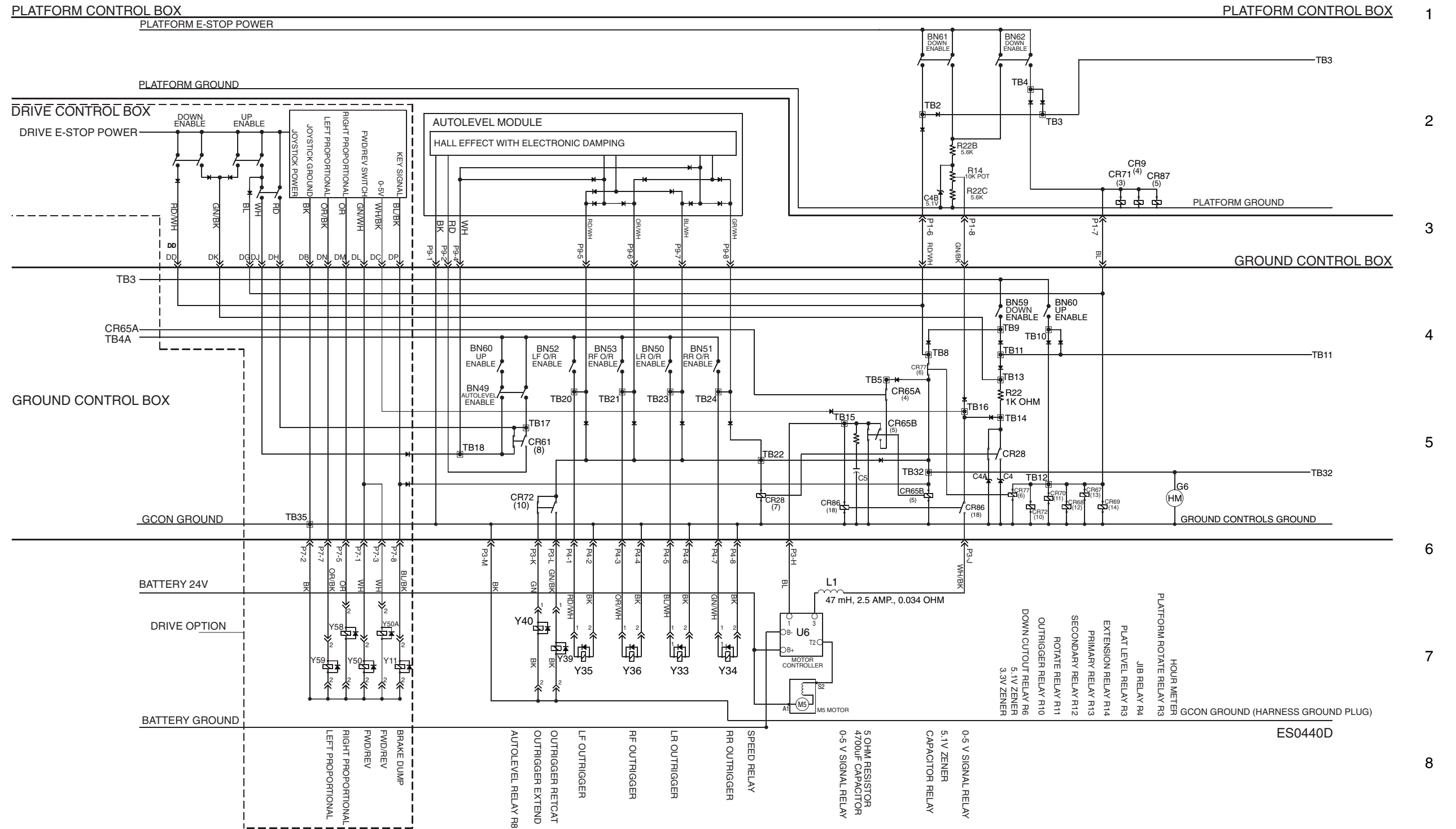

Electrical Schematic - ANSI/CSA
(from serial number TZ5010-145 to TZ5011-131)

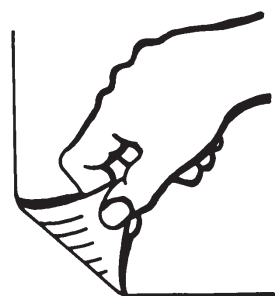

Electrical Schematic - ANSI/CSA, 3 of 3 (from serial number TZ5010-145 to TZ5011-131)

N M L K J I H G F E D C B A

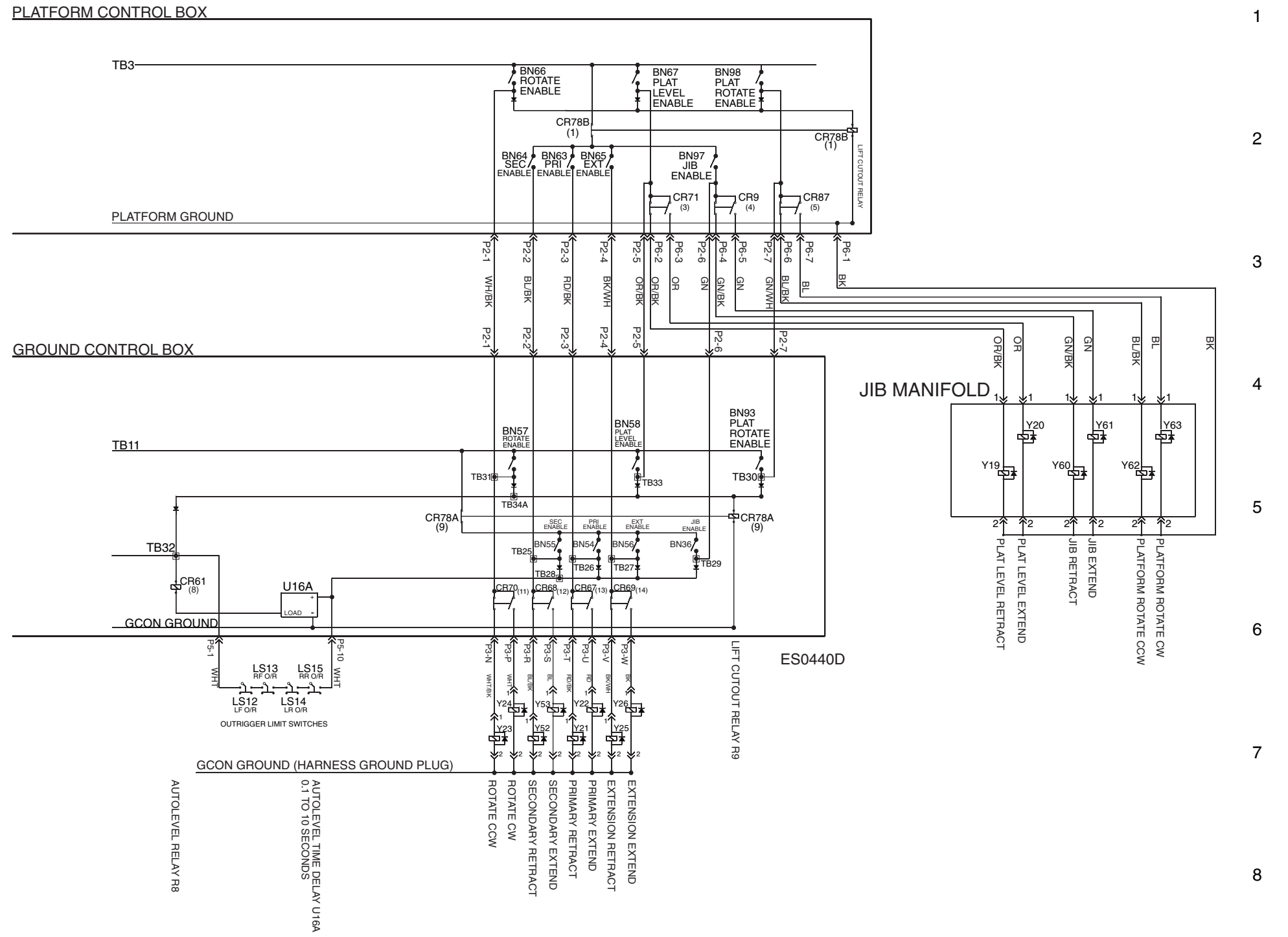

Electrical Schematic - ANSI/CSA
(from serial number TZ5010-145 to TZ5011-131)

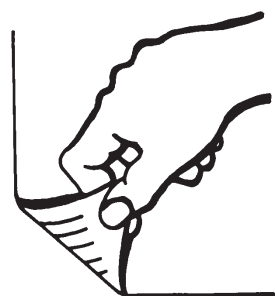

Electrical Schematic - ANSI/CSA
(from serial number TZ5011-132 to TZ5011-310)

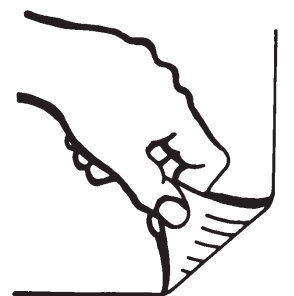
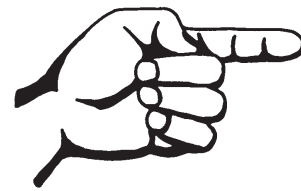

Electrical Schematic - ANSI/CSA, 1 of 3
(from serial number TZ5011-132 to TZ5011-310)

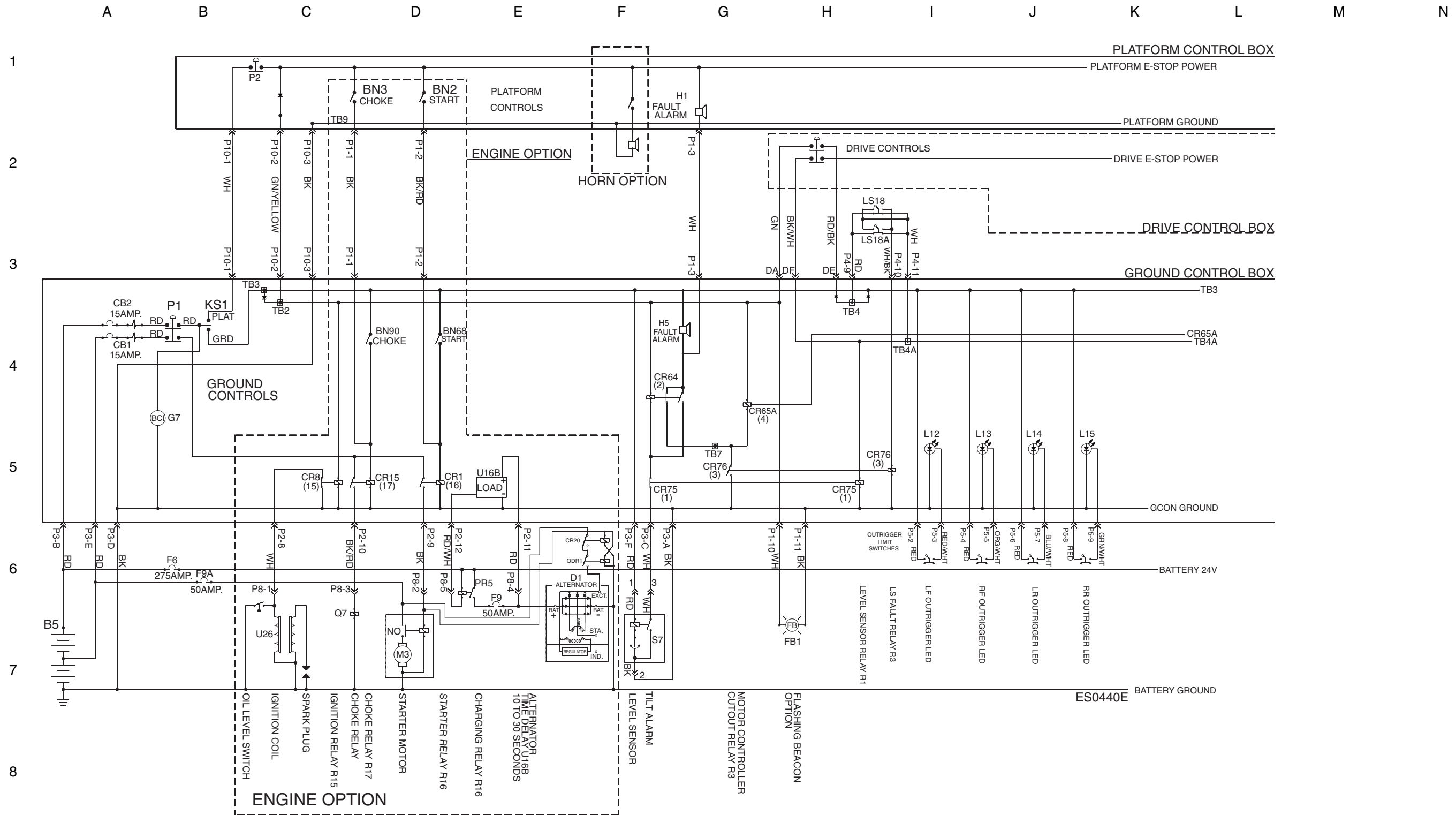

Electrical Schematic - ANSI/CSA, 2 of 3 (from serial number TZ5011-132 to TZ5011-310)

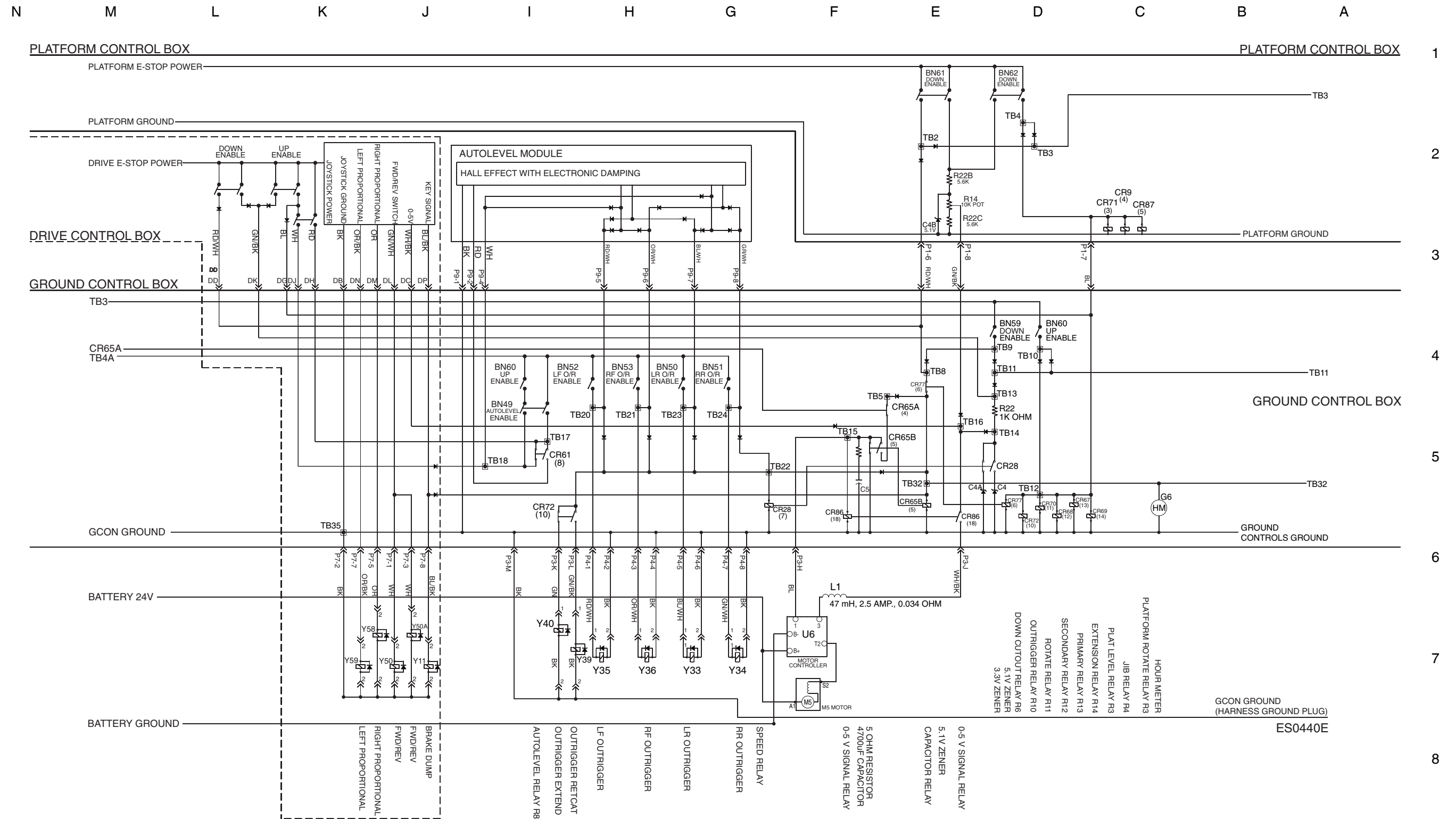

Electrical Schematic - ANSI/CSA
(from serial number TZ5011-132 to TZ5011-310)

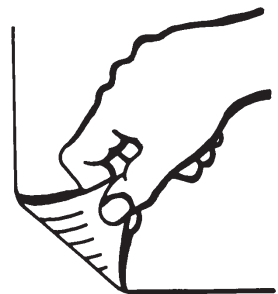

Electrical Schematic - ANSI/CSA, 3 of 3 (from serial number TZ5011-132 to TZ5011-310)

N M L K J I H G F E D C B A

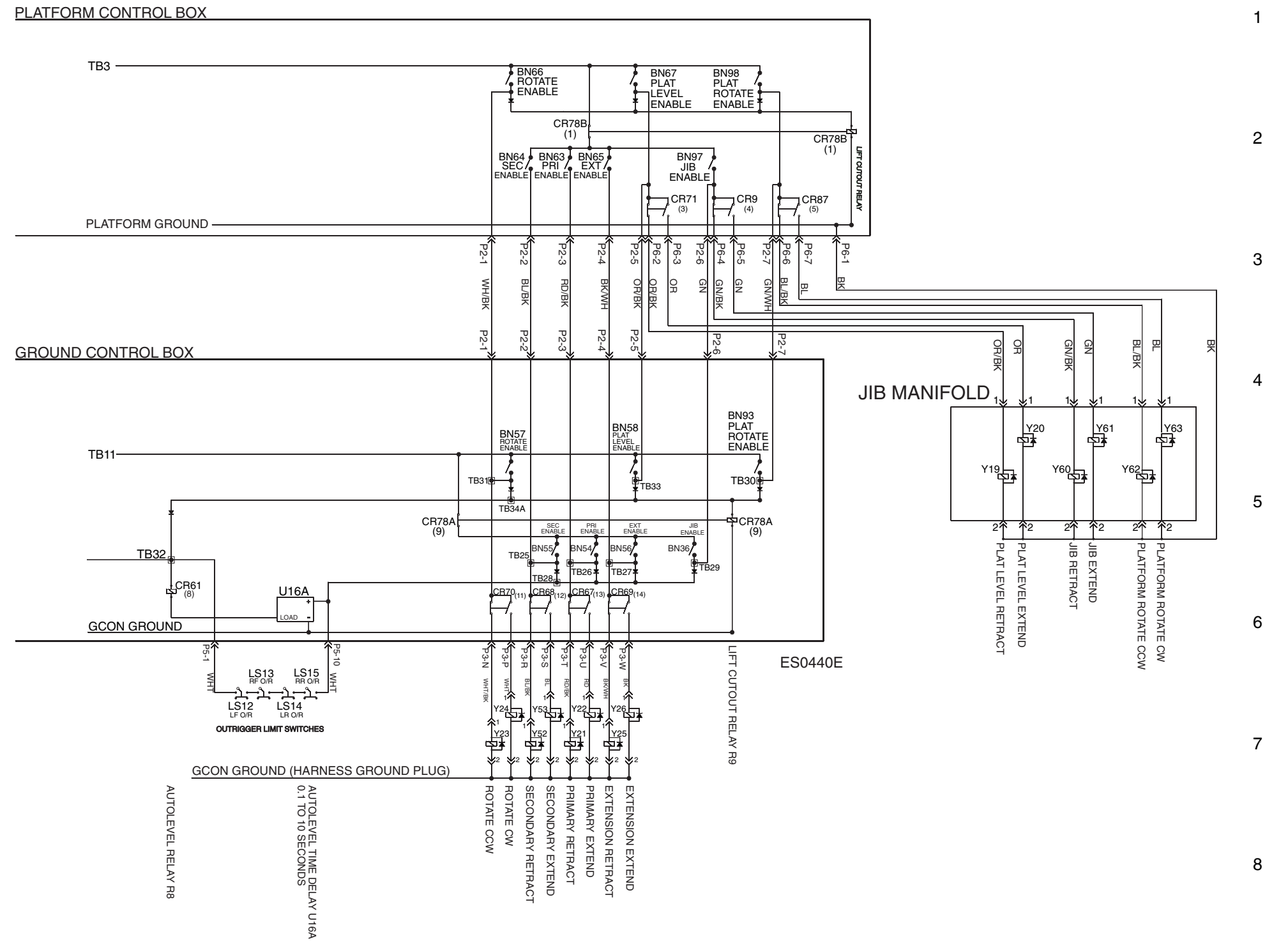

Electrical Schematic - ANSI/CSA
(from serial number TZ5011-132 to TZ5011-310)

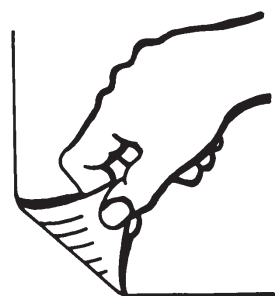

**Electrical Schematic - ANSI/CSA
(from serial number TZ5011-311)**

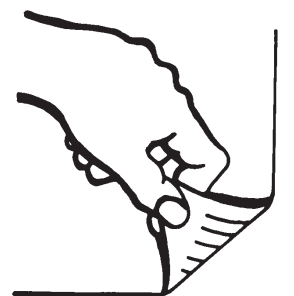
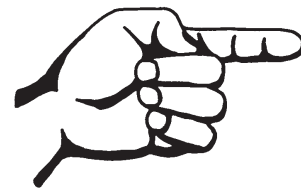

Electrical Schematic - ANSI/CSA, 1 of 3 (from serial number TZ5011-311)

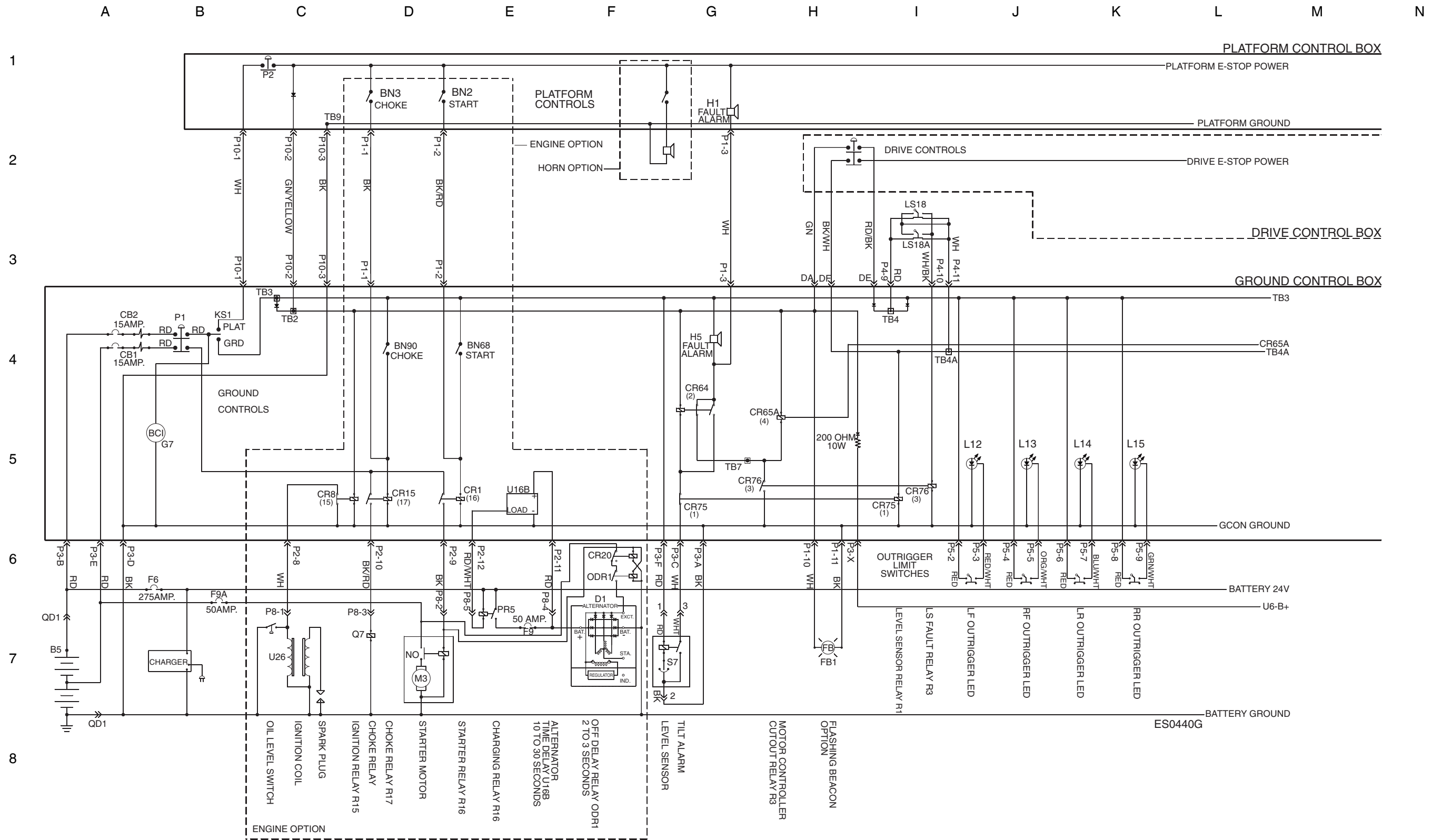

TZ-50

Part No. 84577

Electrical Schematic - ANSI/CSA, 2 of 3 (from serial number TZ5011-311)

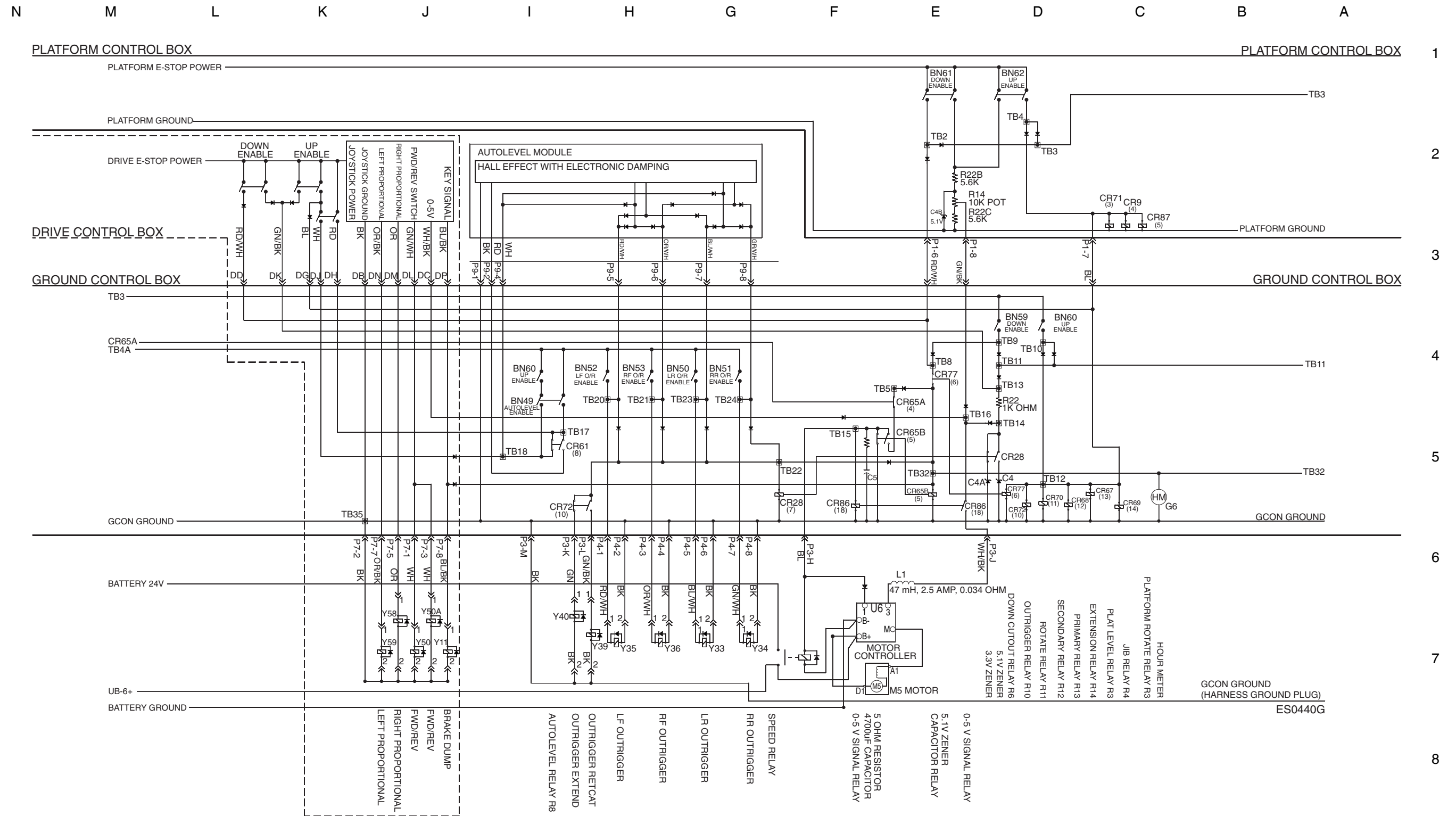

**Electrical Schematic - ANSI/CSA
(from serial number TZ5011-311)**

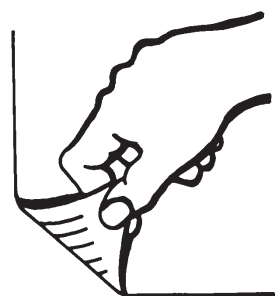

Electrical Schematic - ANSI/CSA, 3 of 3 (from serial number TZ5011-311)

N M L K J I H G F E D C B A

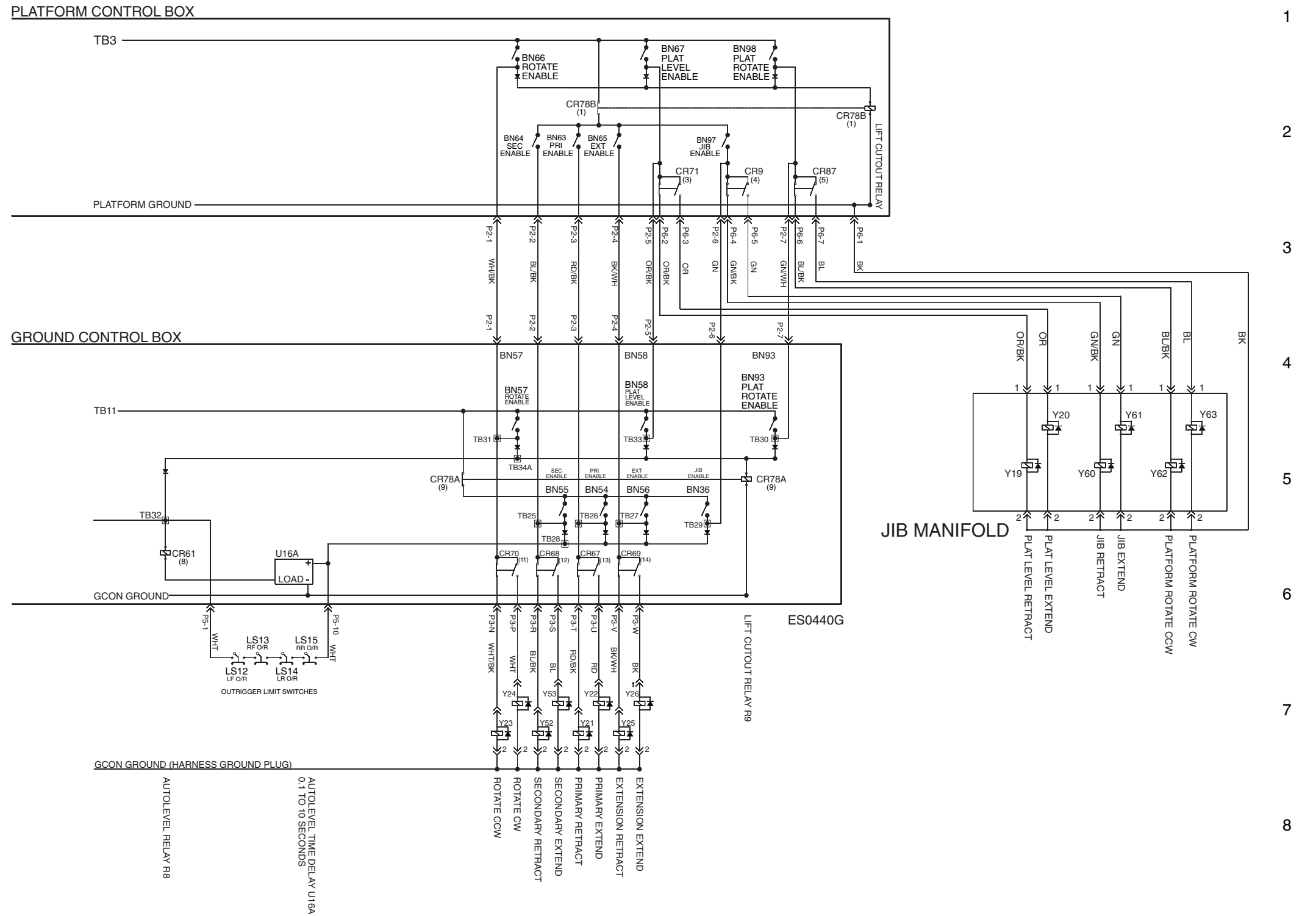

**Electrical Schematic - ANSI/CSA
(from serial number TZ5011-311)**

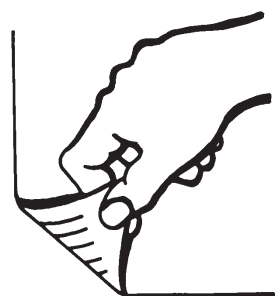

**Electrical Schematic - AS/CE
(to serial number TZ5004-181)**

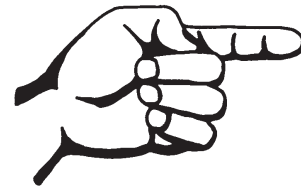

Electrical Schematic - AS/CE, 1 of 3 (to serial number TZ5004-181)

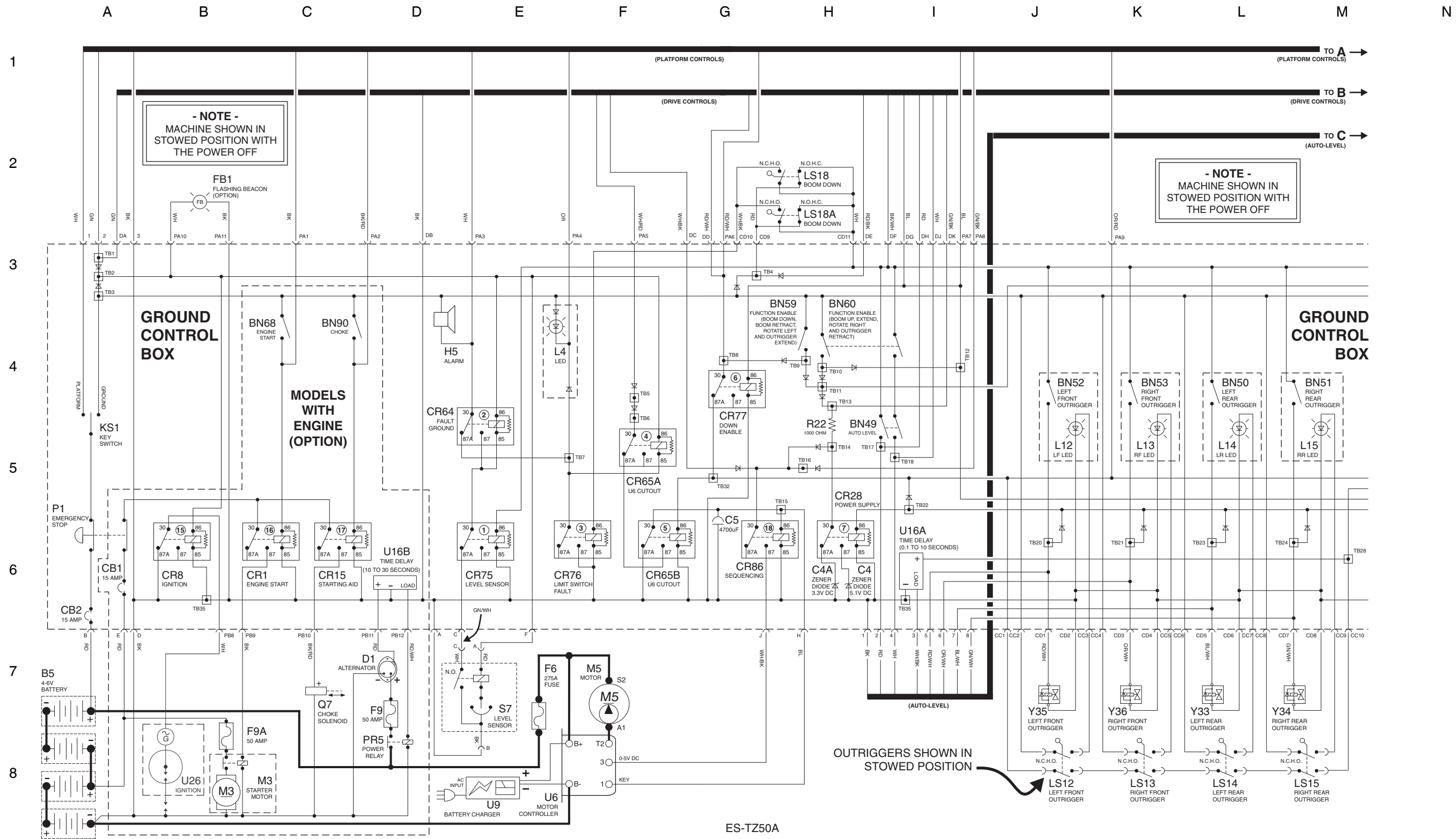

ES-TZ50A



TZ-50

Part No. 84577

Electrical Schematic - AS/CE, 2 of 3 (to serial number TZ5004-181)

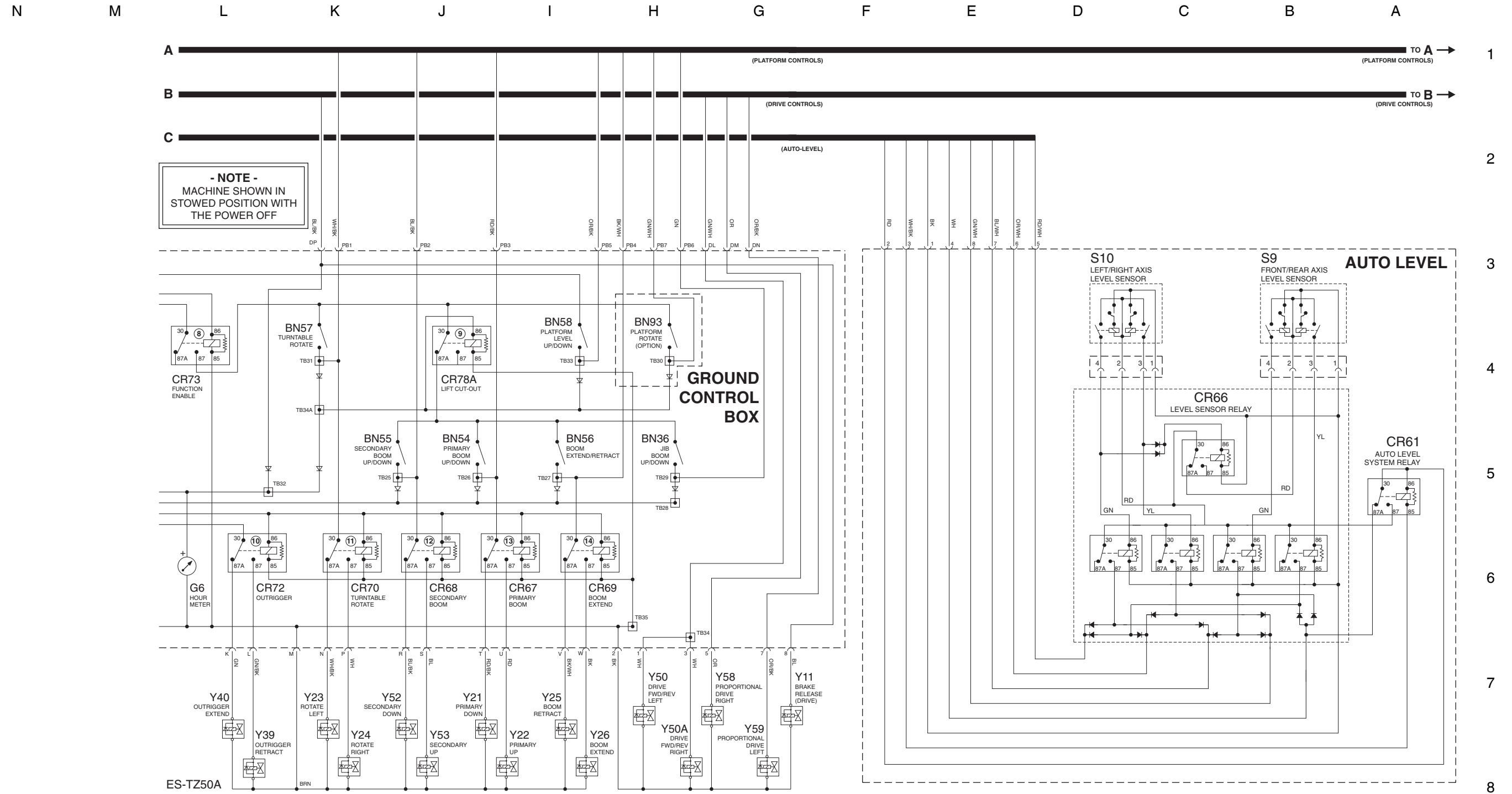

**Electrical Schematic - AS/CE
(to serial number TZ5004-181)**

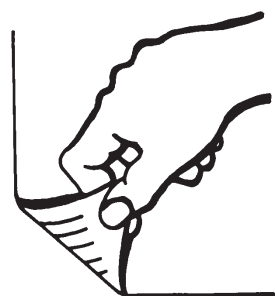

Electrical Schematic - AS/CE, 3 of 3 (to serial number TZ5004-181)

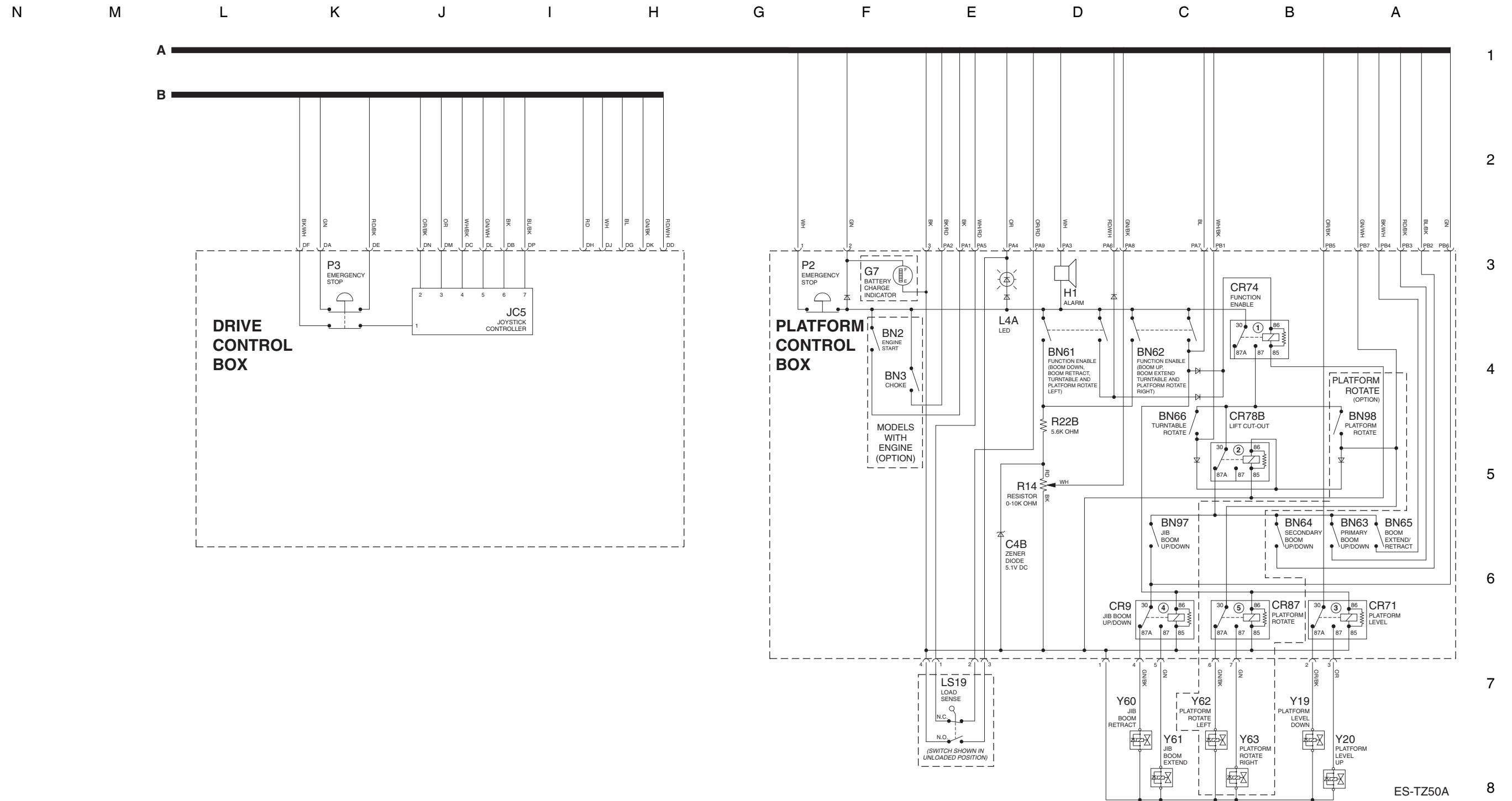

ES-TZ50A



**Electrical Schematic - AS/CE
(to serial number TZ5004-181)**

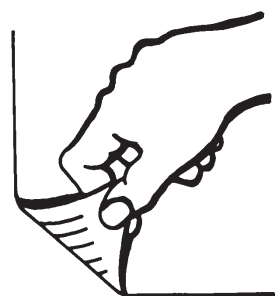

Electrical Schematic - AS/CE
(from serial number TZ5004-182 to TZ5005-210)

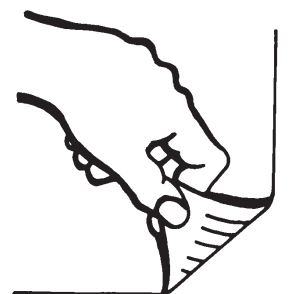
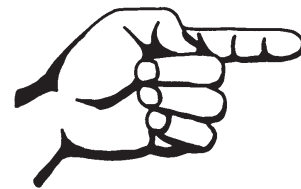

Electrical Schematic - AS/CE, 1 of 3 (from serial number TZ5004-182 to TZ5005-210)

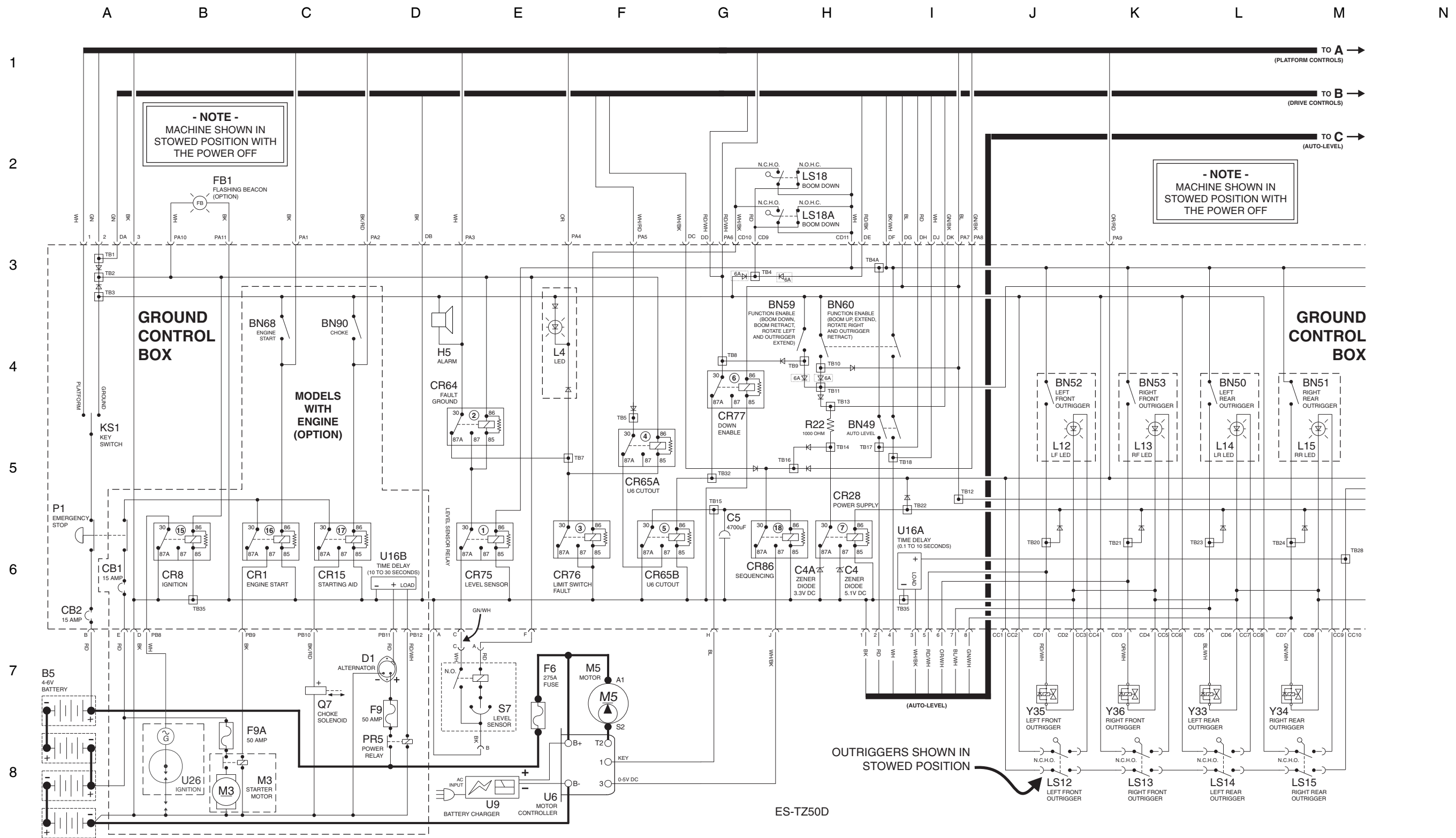

Electrical Schematic - AS/CE, 2 of 3 (from serial number TZ5004-182 to TZ5005-210)

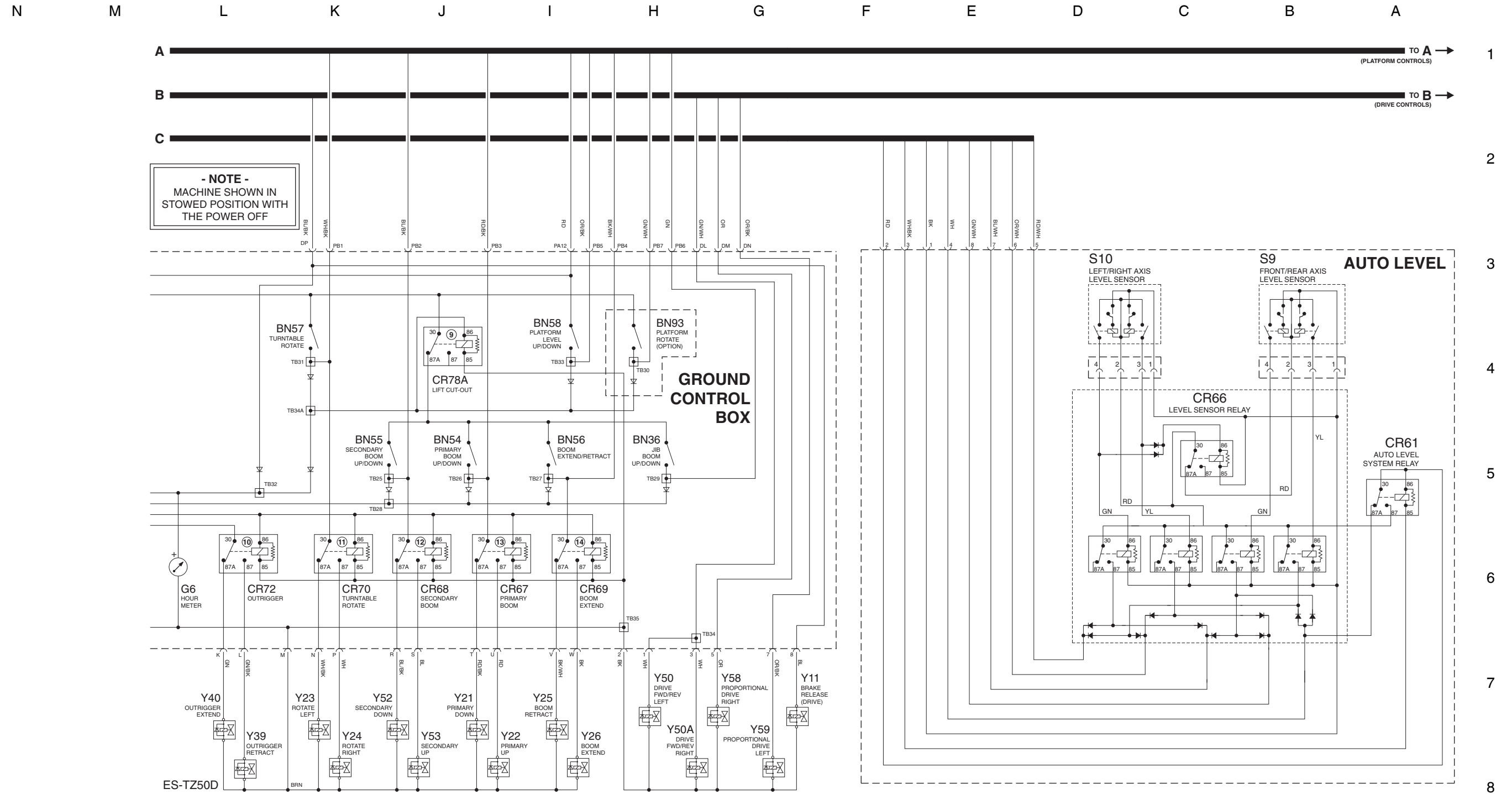

Electrical Schematic - AS/CE
(from serial number TZ5004-182 to TZ5005-210)

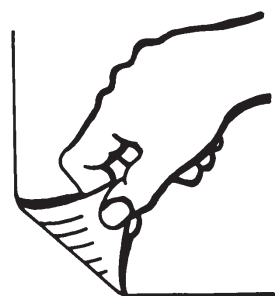

Electrical Schematic - AS/CE, 3 of 3 (from serial number TZ5004-182 to TZ5005-210)

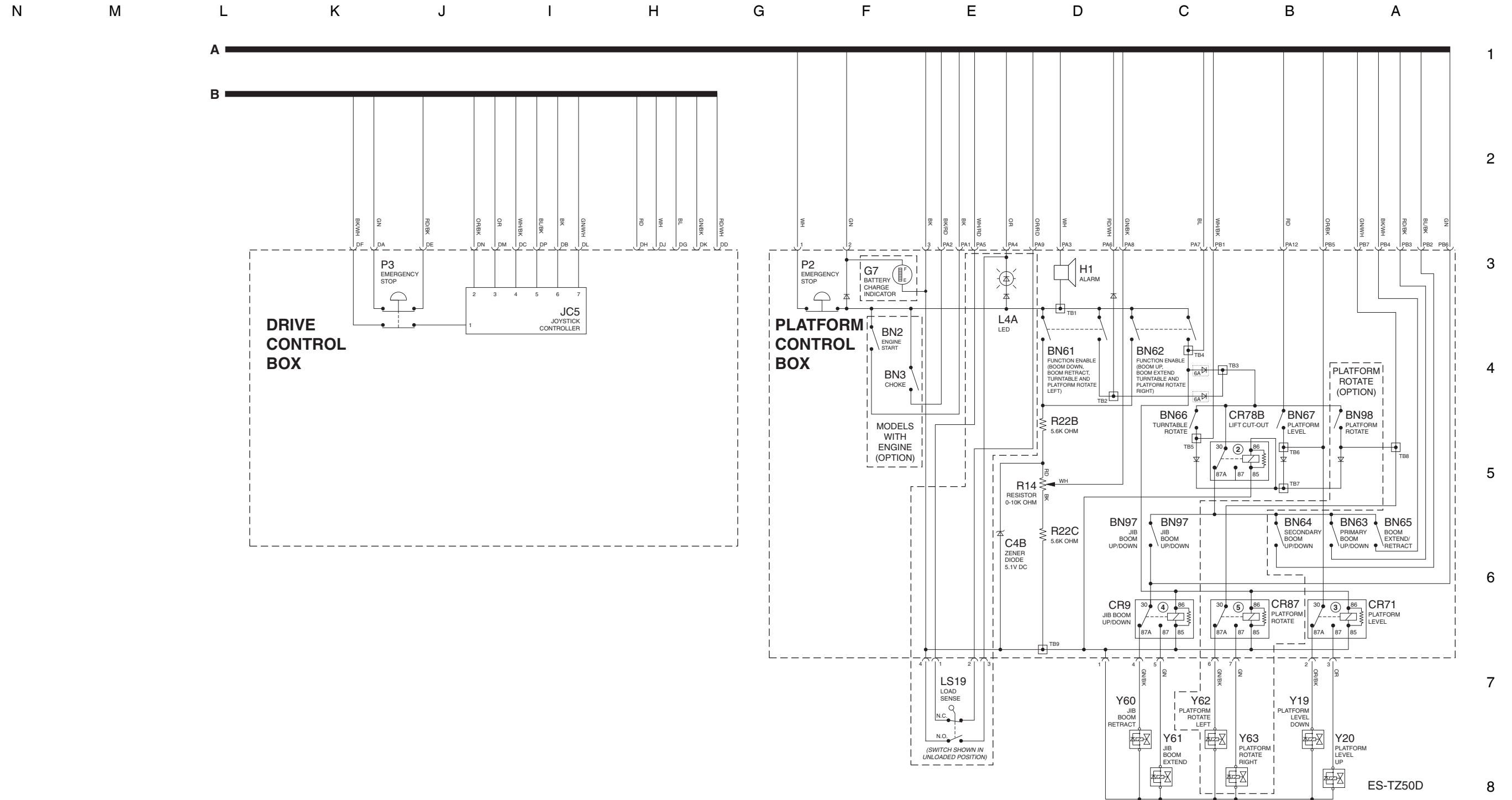

Electrical Schematic - AS/CE
(from serial number TZ5004-182 to TZ5005-210)

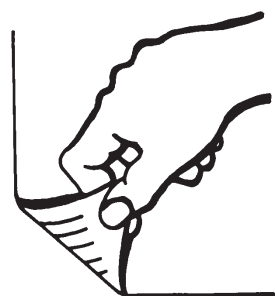

Electrical Schematic - AS/CE
(from serial number TZ5005-211 to TZ5005-284)

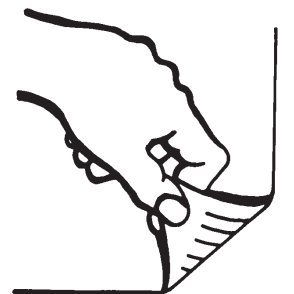
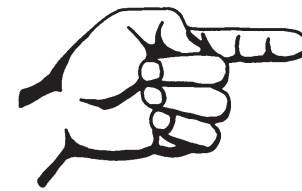

Electrical Schematic - AS/CE, 1 of 3 (from serial number TZ5005-211 to TZ5005-284)

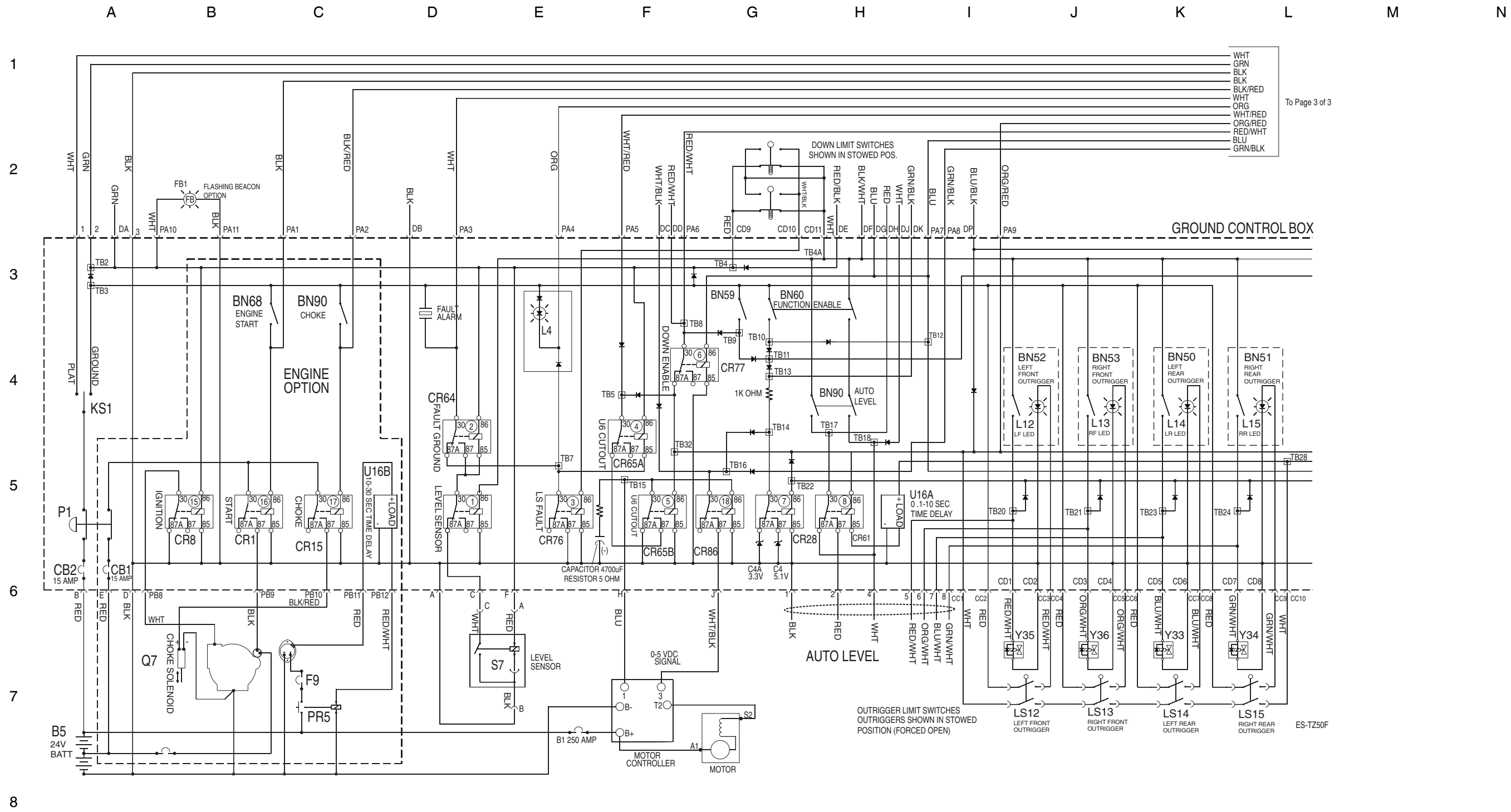

To Page 3 of 3

Electrical Schematic - AS/CE, 2 of 3 (from serial number TZ5005-211 to TZ5005-284)

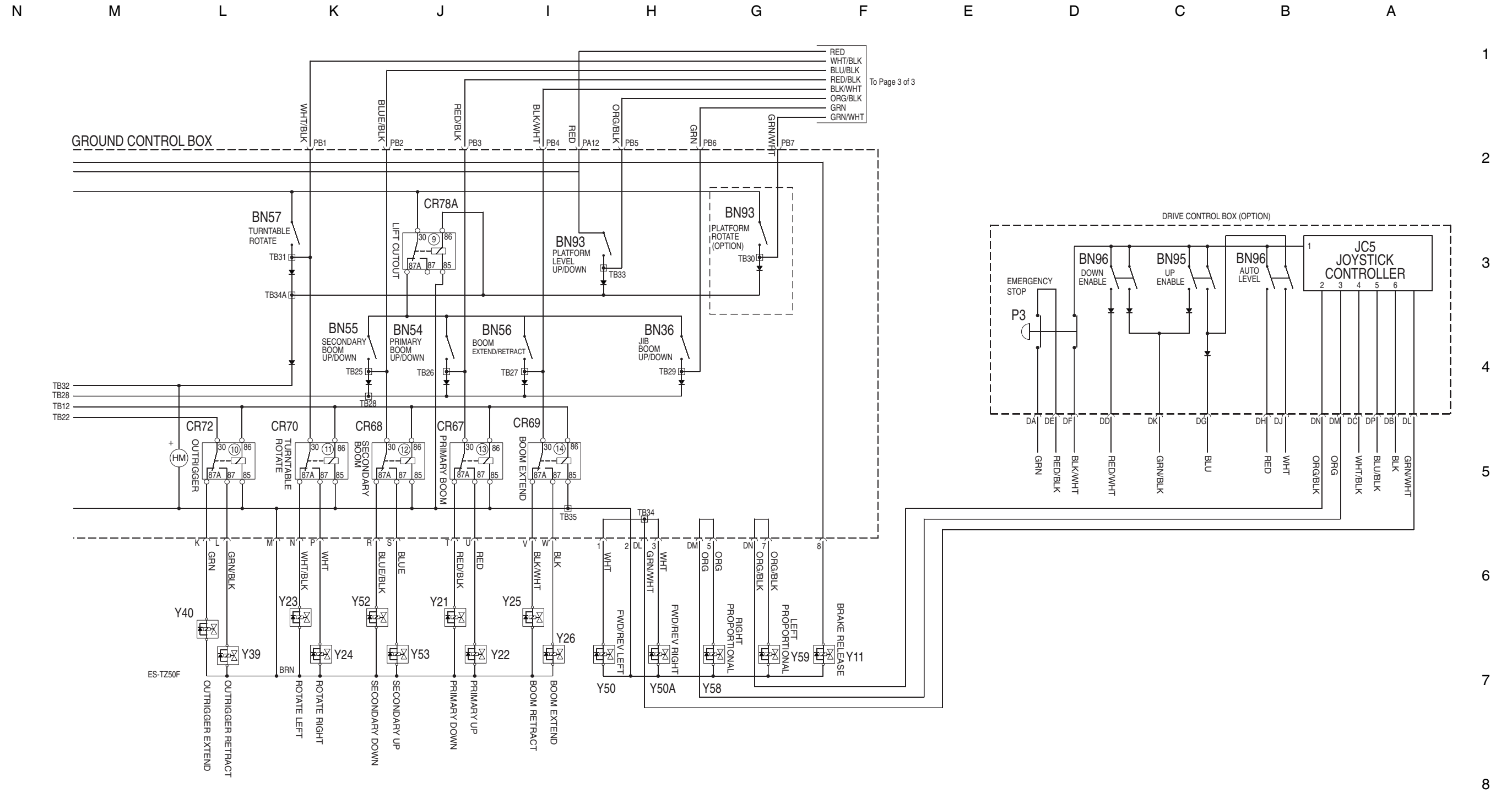

Electrical Schematic - AS/CE
(from serial number TZ5005-211 to TZ5005-284)

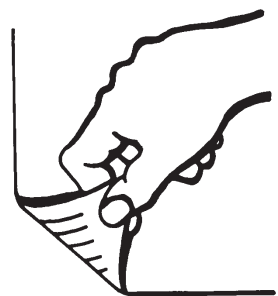

Electrical Schematic - AS/CE, 3 of 3 (from serial number TZ5005-211 to TZ5005-284)

N M L K J I H G F E D C B A

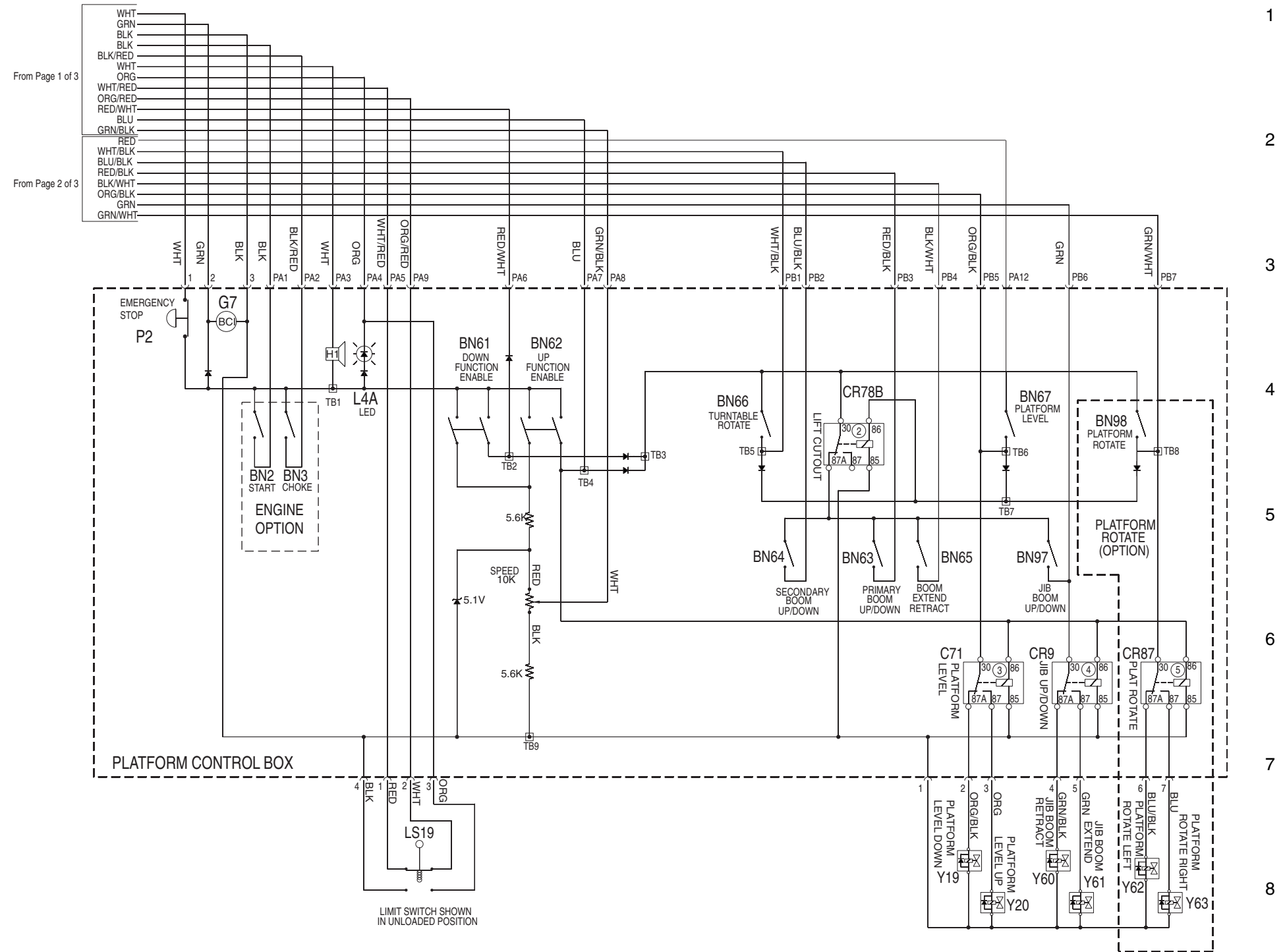

Electrical Schematic - AS/CE
(from serial number TZ5005-211 to TZ5005-284)

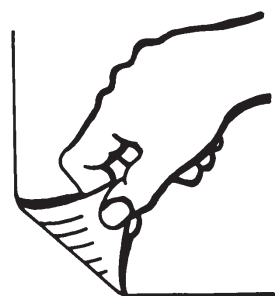

Electrical Schematic - AS/CE
(from serial number TZ5005-285 to TZ5010-144)

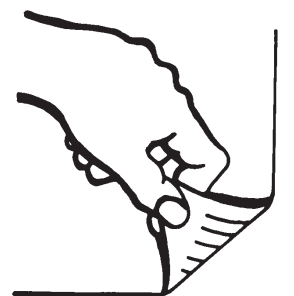
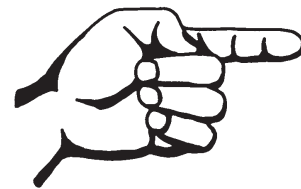

Electrical Schematic - AS/CE, 1 of 3
(from serial number TZ5005-285 to TZ5010-144)

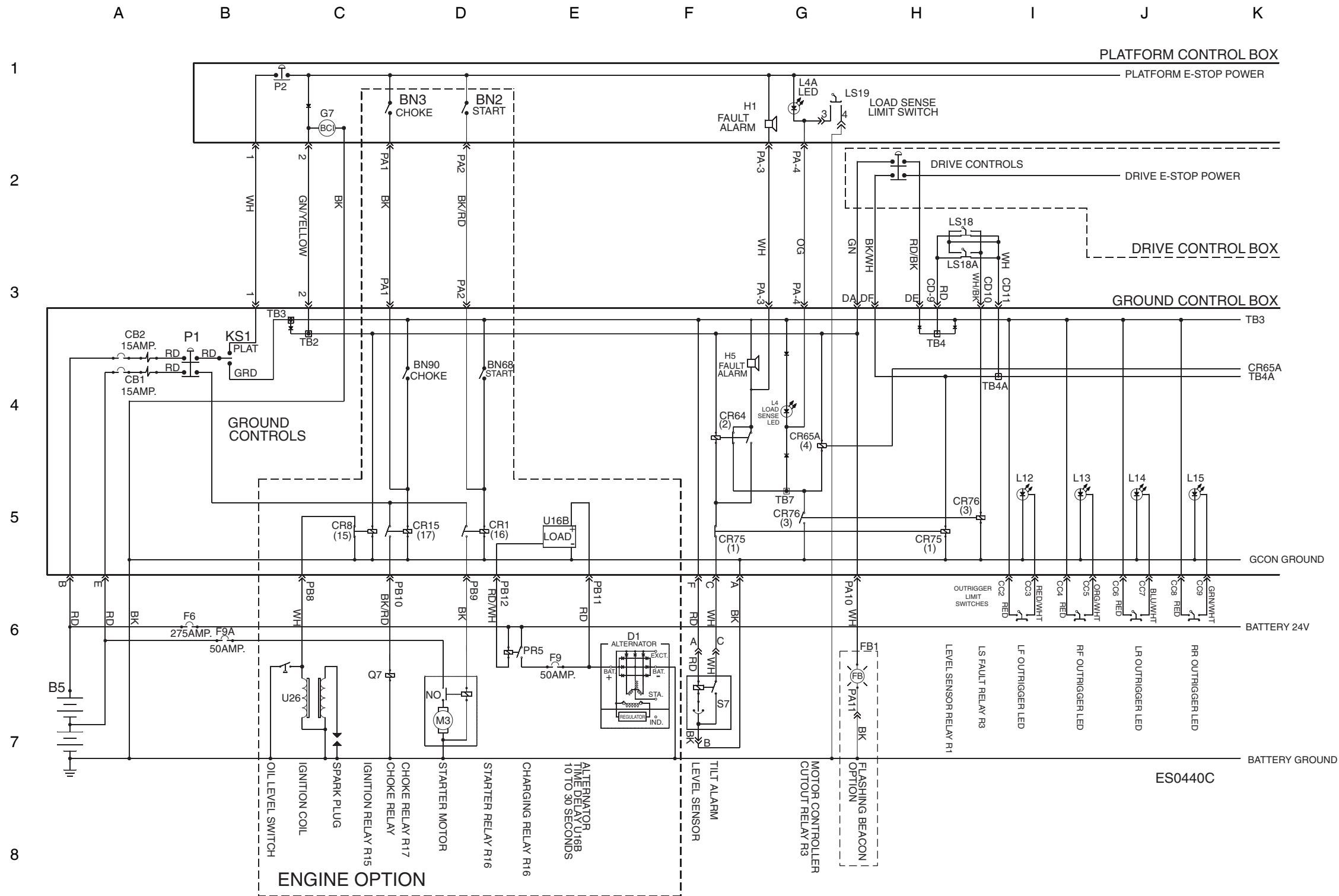

Electrical Schematic - AS/CE, 2 of 3 (from serial number TZ5005-285 to TZ5010-144)

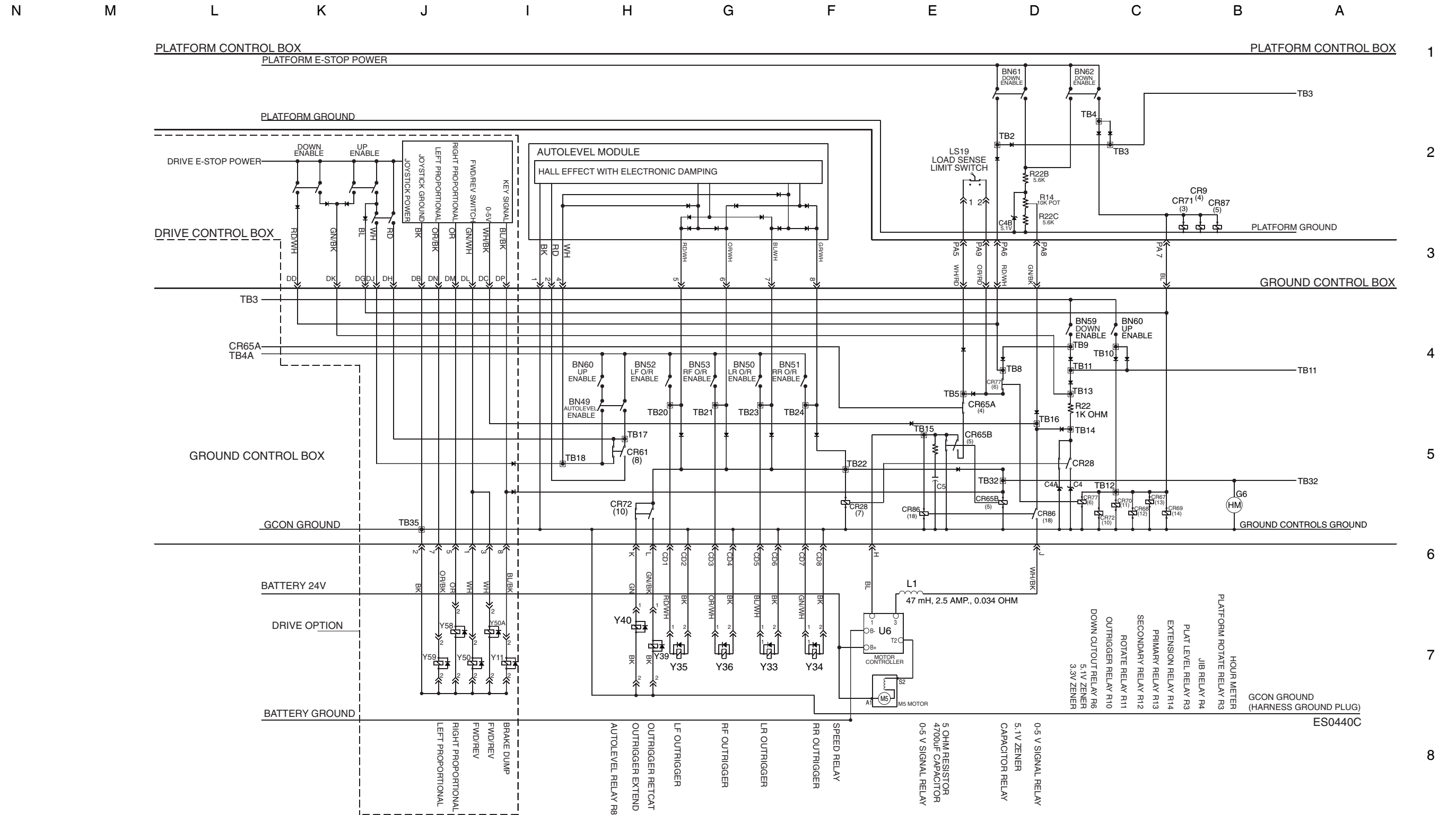

Electrical Schematic - AS/CE
(from serial number TZ5005-285 to TZ5010-144)

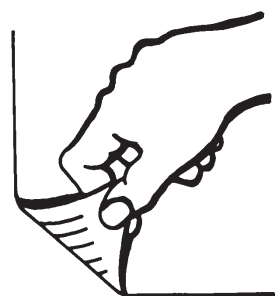

Electrical Schematic - AS/CE, 3 of 3 (from serial number TZ5005-285 to TZ5010-144)

N M L K J I H G F E D C B A

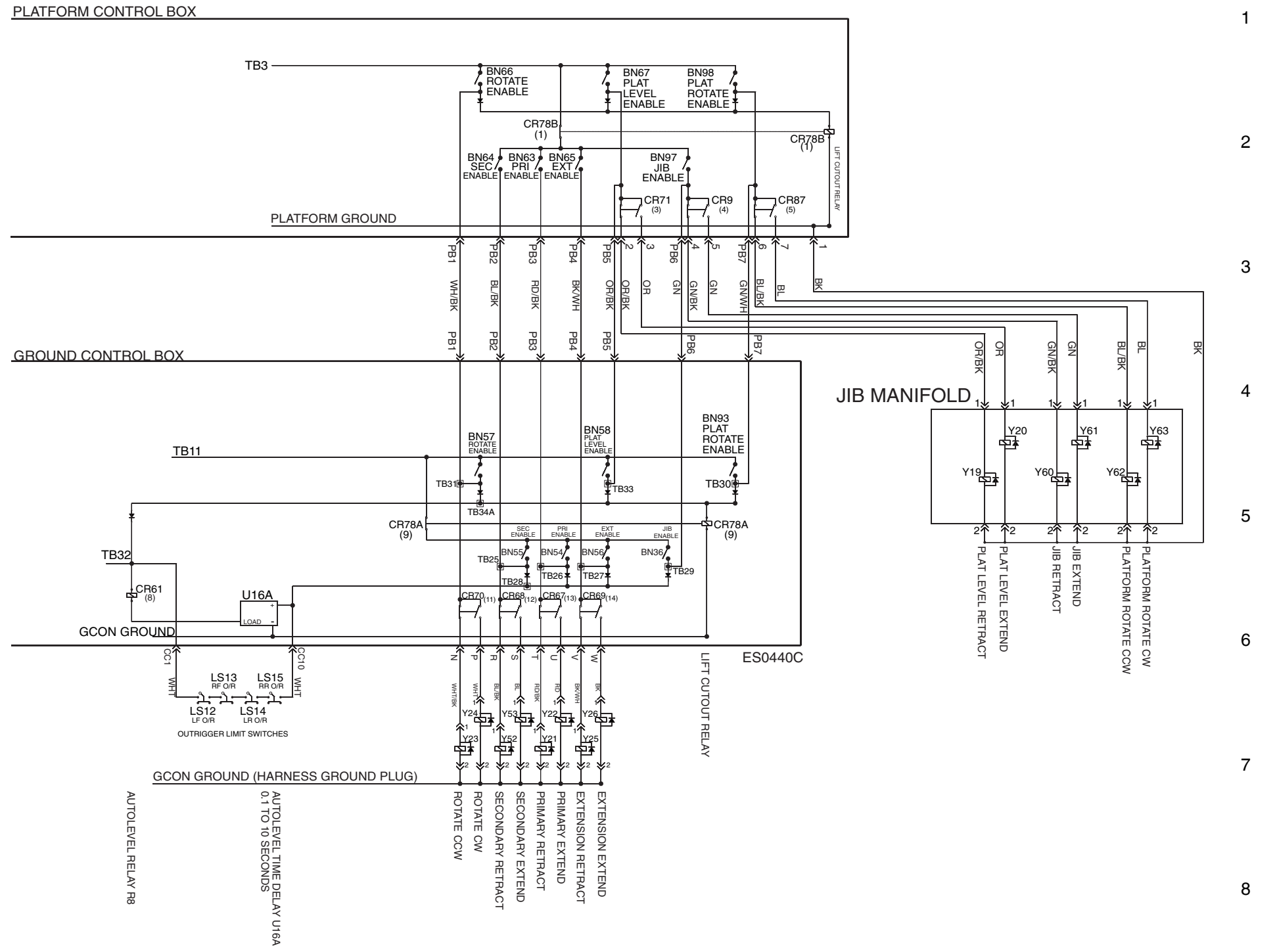

Electrical Schematic - AS/CE
(from serial number TZ5005-285 to TZ5010-144)

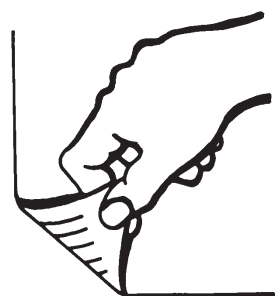

Electrical Schematic - AS/CE
(from serial number TZ5010-145 to TZ5011-131)

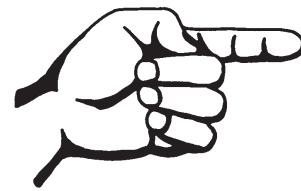

Electrical Schematic - AS/CE, 1 of 3
(from serial number TZ5010-145 to TZ5011-131)

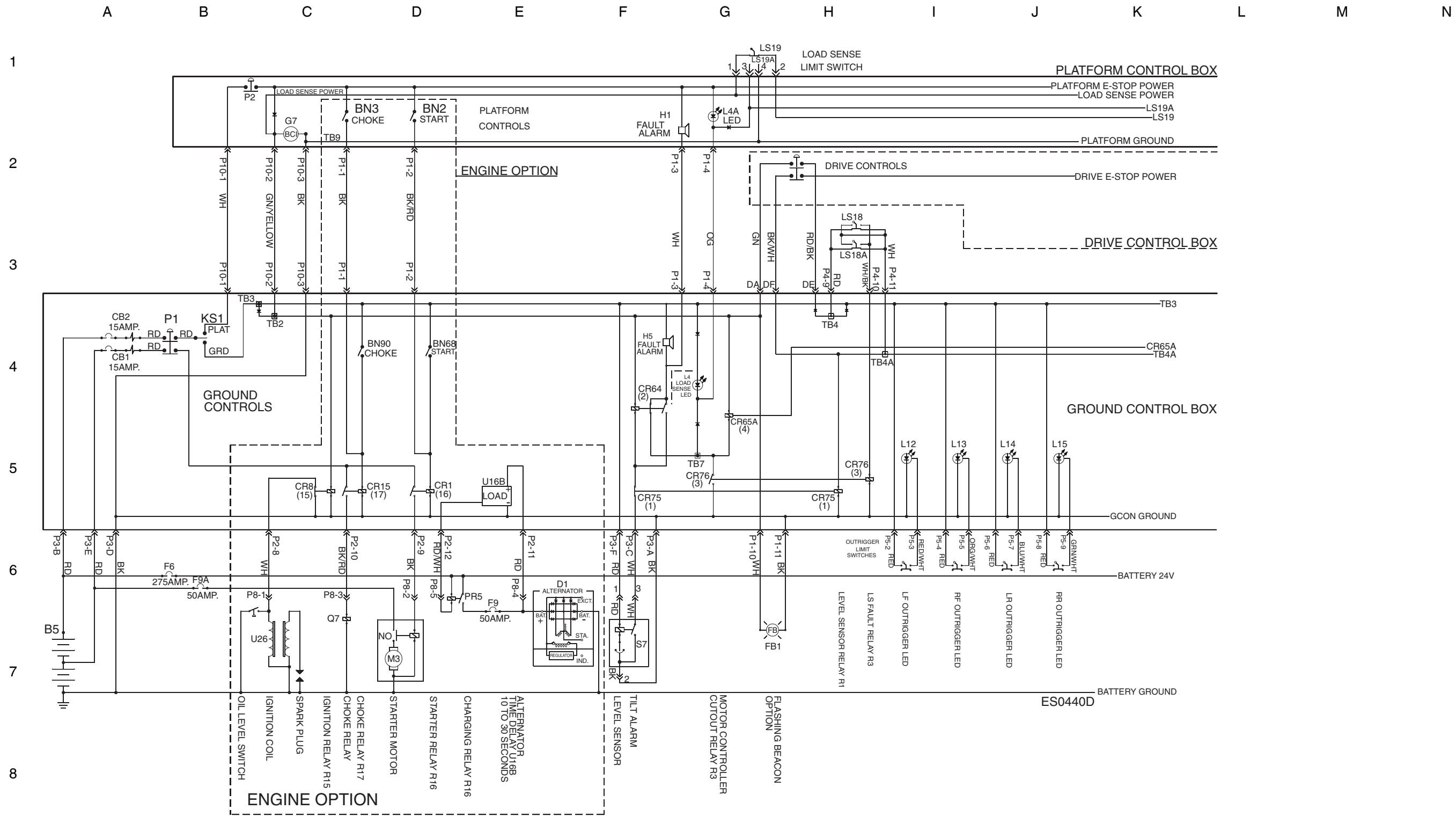

Electrical Schematic - AS/CE
(from serial number TZ5010-145 to TZ5011-131)

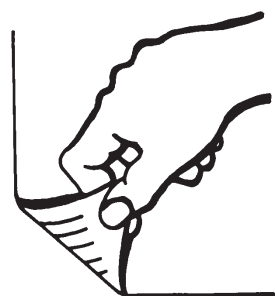

Electrical Schematic - AS/CE, 3 of 3 (from serial number TZ5010-145 to TZ5011-131)

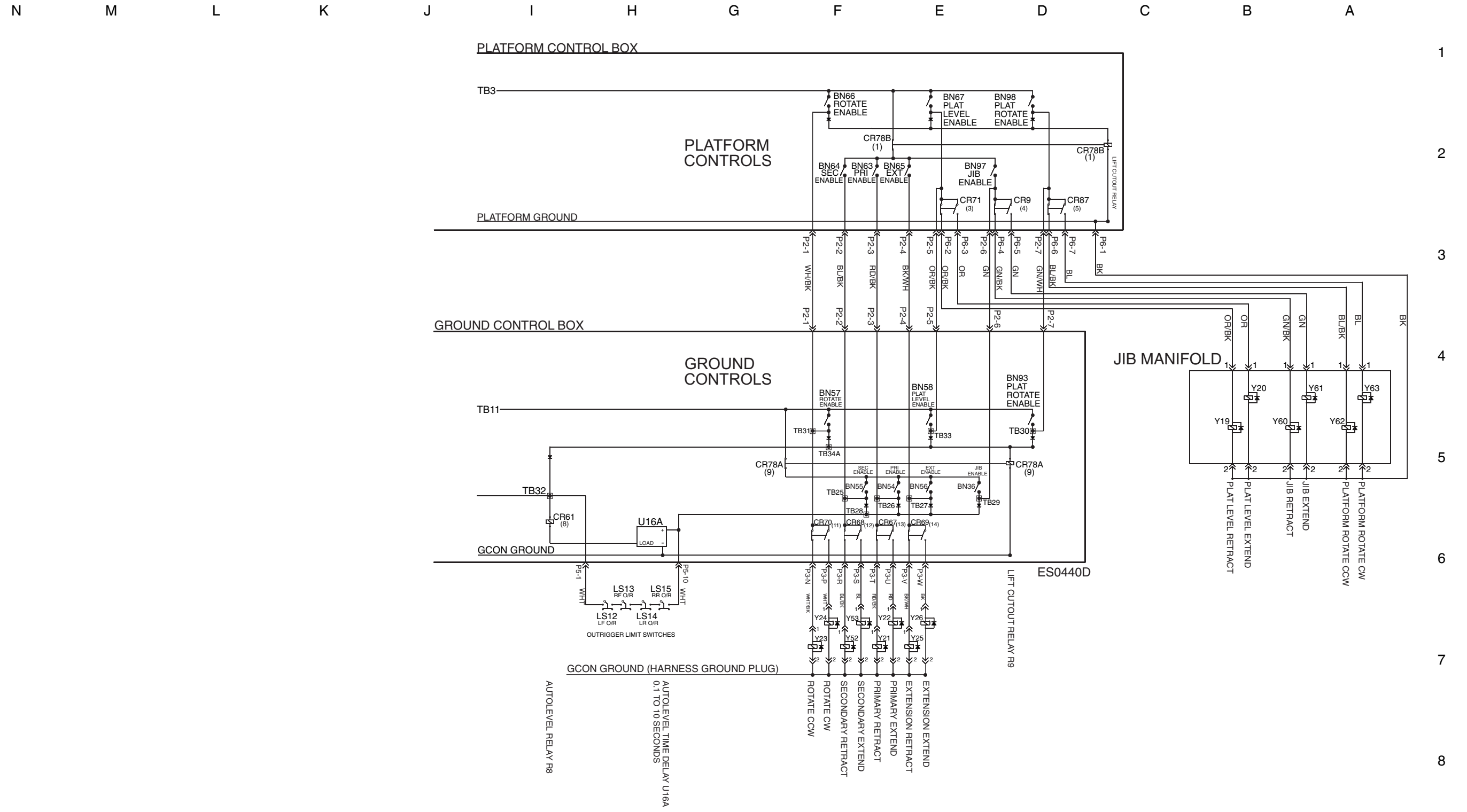

Electrical Schematic - AS/CE
(from serial number TZ5010-145 to TZ5011-131)

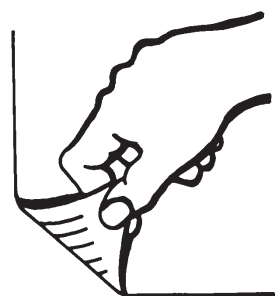

Electrical Schematic - AS/CE
(from serial number TZ5011-132 to TZ5011-310)

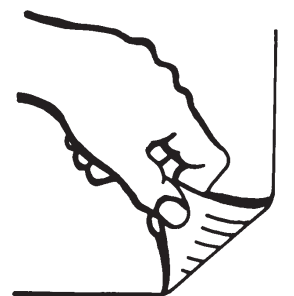
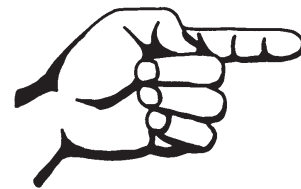

Electrical Schematic - AS/CE, 1 of 3 (from serial number TZ5011-132 to TZ5011-310)

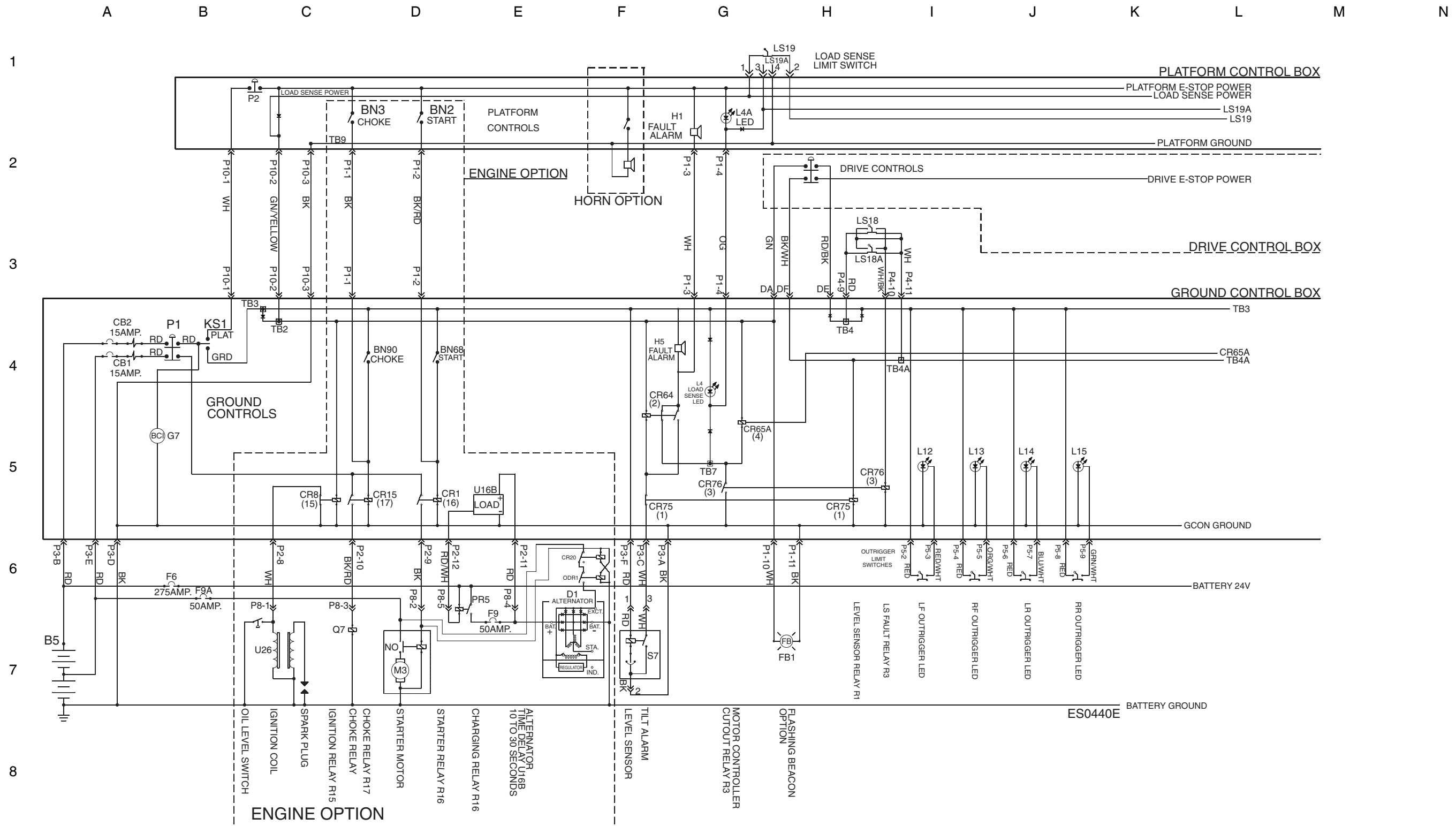

Electrical Schematic - AS/CE, 2 of 3 (from serial number TZ5011-132 to TZ5011-310)

N M L K J I H G F E D C B A

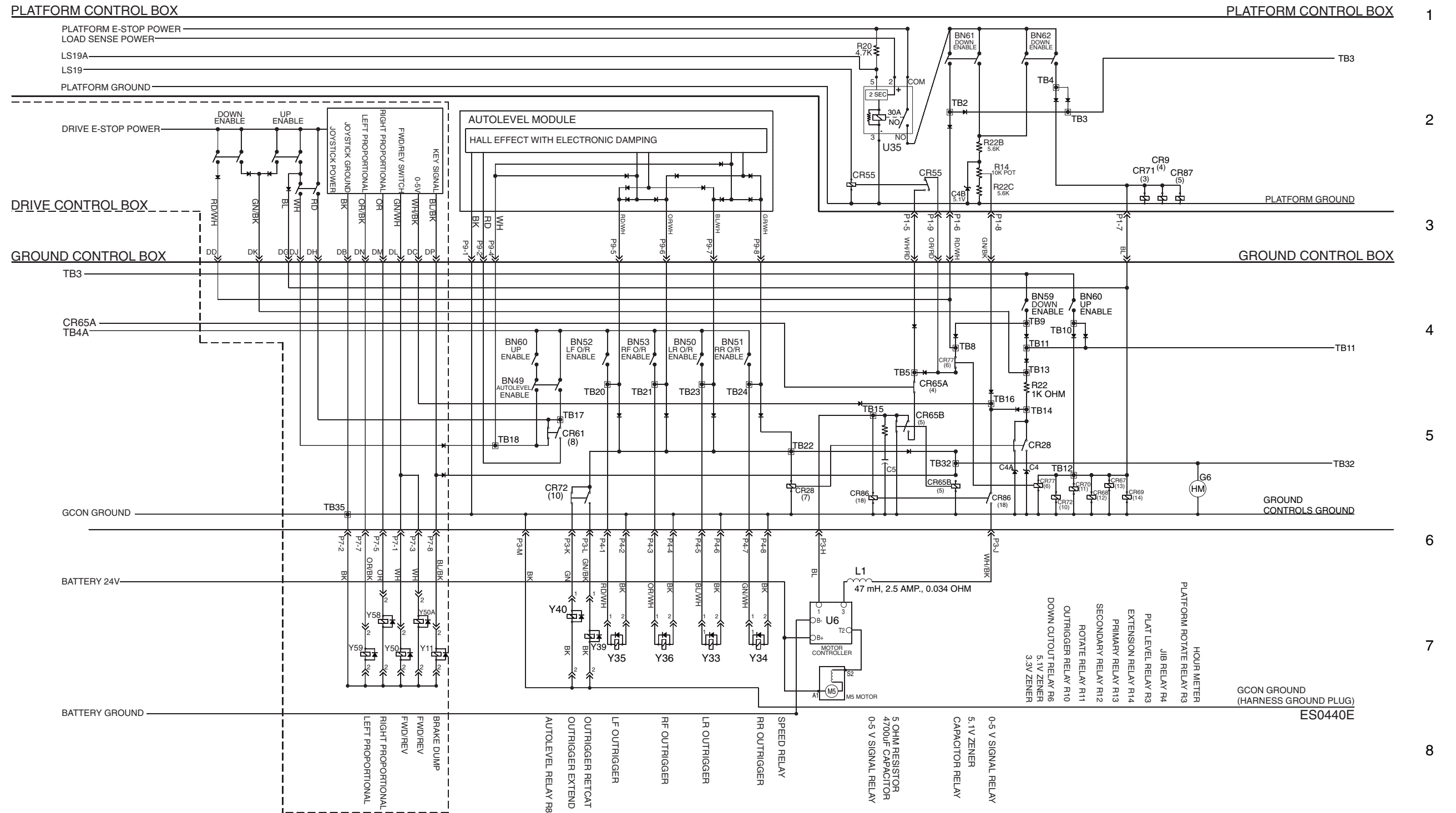

Electrical Schematic - AS/CE
(from serial number TZ5011-132 to TZ5011-310)

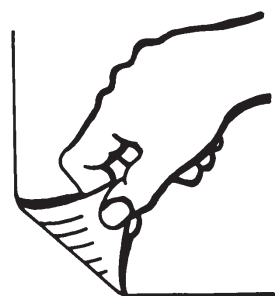

Electrical Schematic - AS/CE, 3 of 3 (from serial number TZ5011-132 to TZ5011-310)

N M L K J I H G F E D C B A

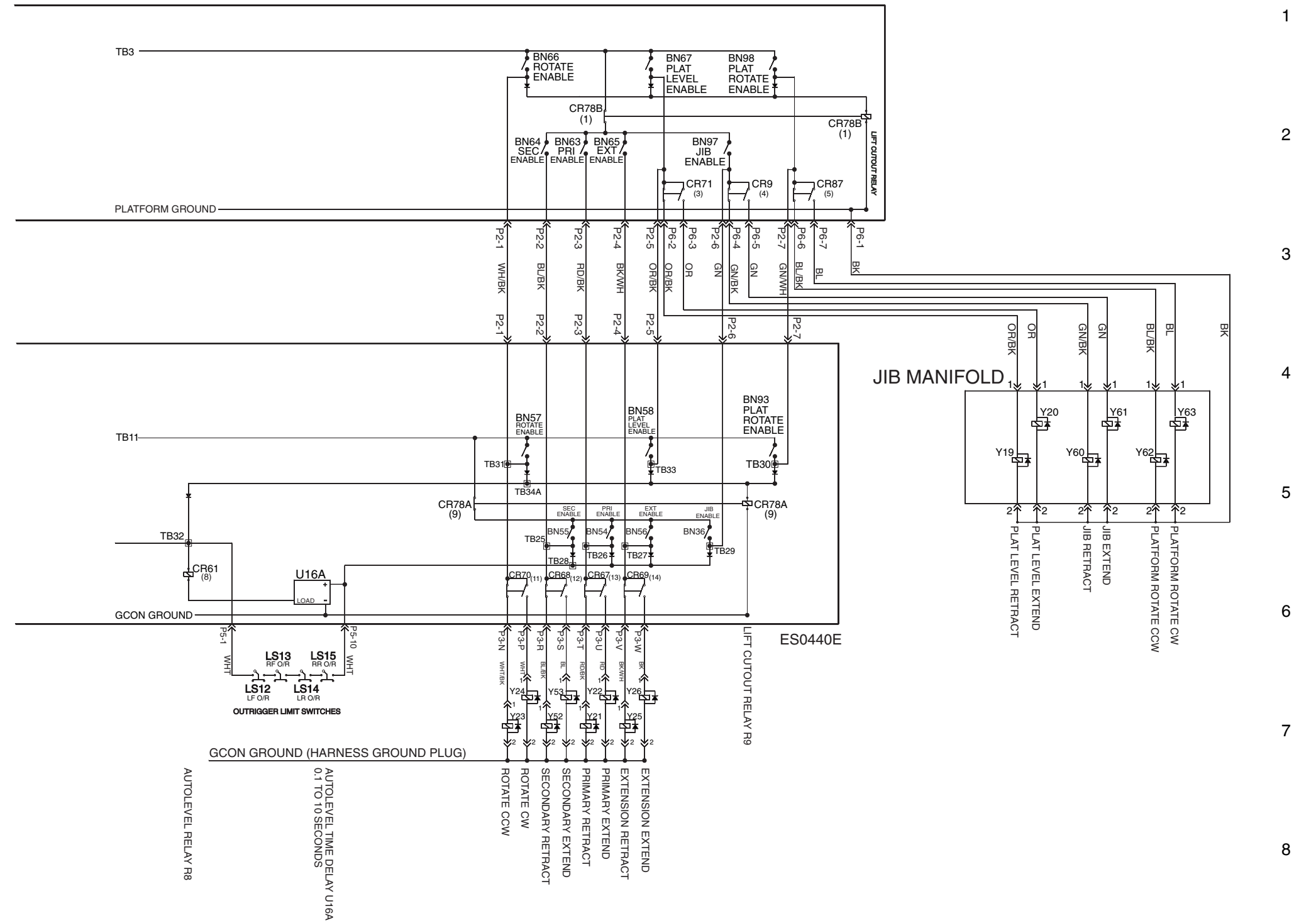

Electrical Schematic - AS/CE
(from serial number TZ5011-132 to TZ5011-310)

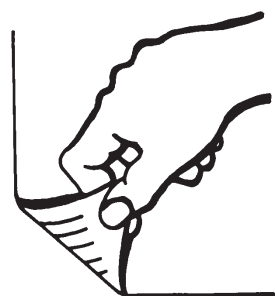

Electrical Schematic - AS/CE
(from serial number TZ5011-311)

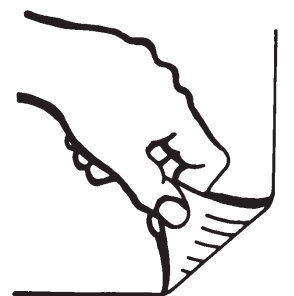
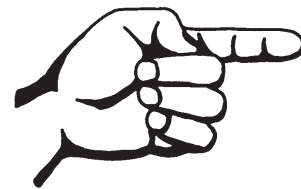

Electrical Schematic - AS/CE, 1 of 3 (from serial number TZ5011-311)

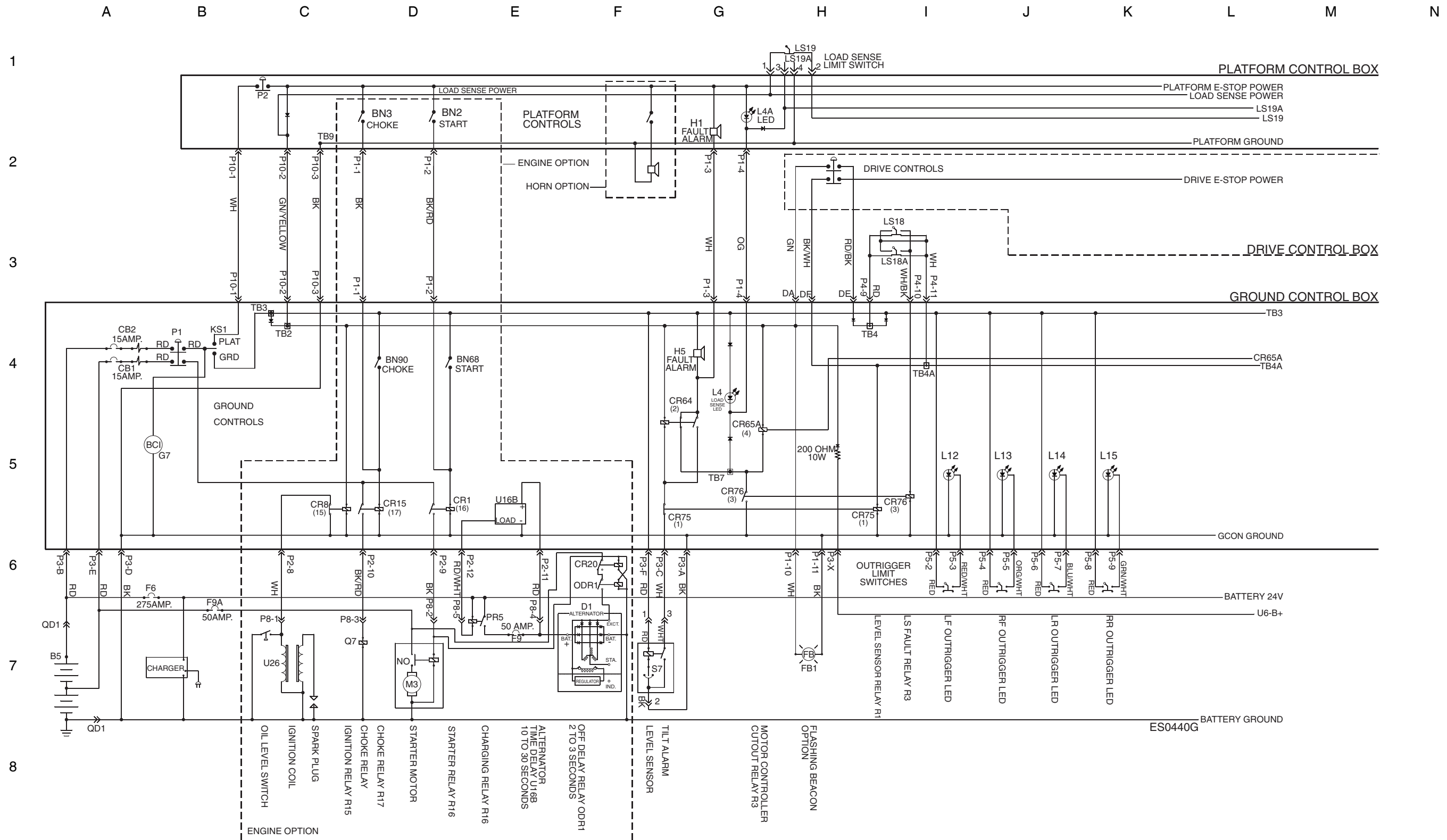

TZ-50

Part No. 84577

Electrical Schematic - AS/CE, 2 of 3 (from serial number TZ5011-311)

N M L K J I H G F E D C B A

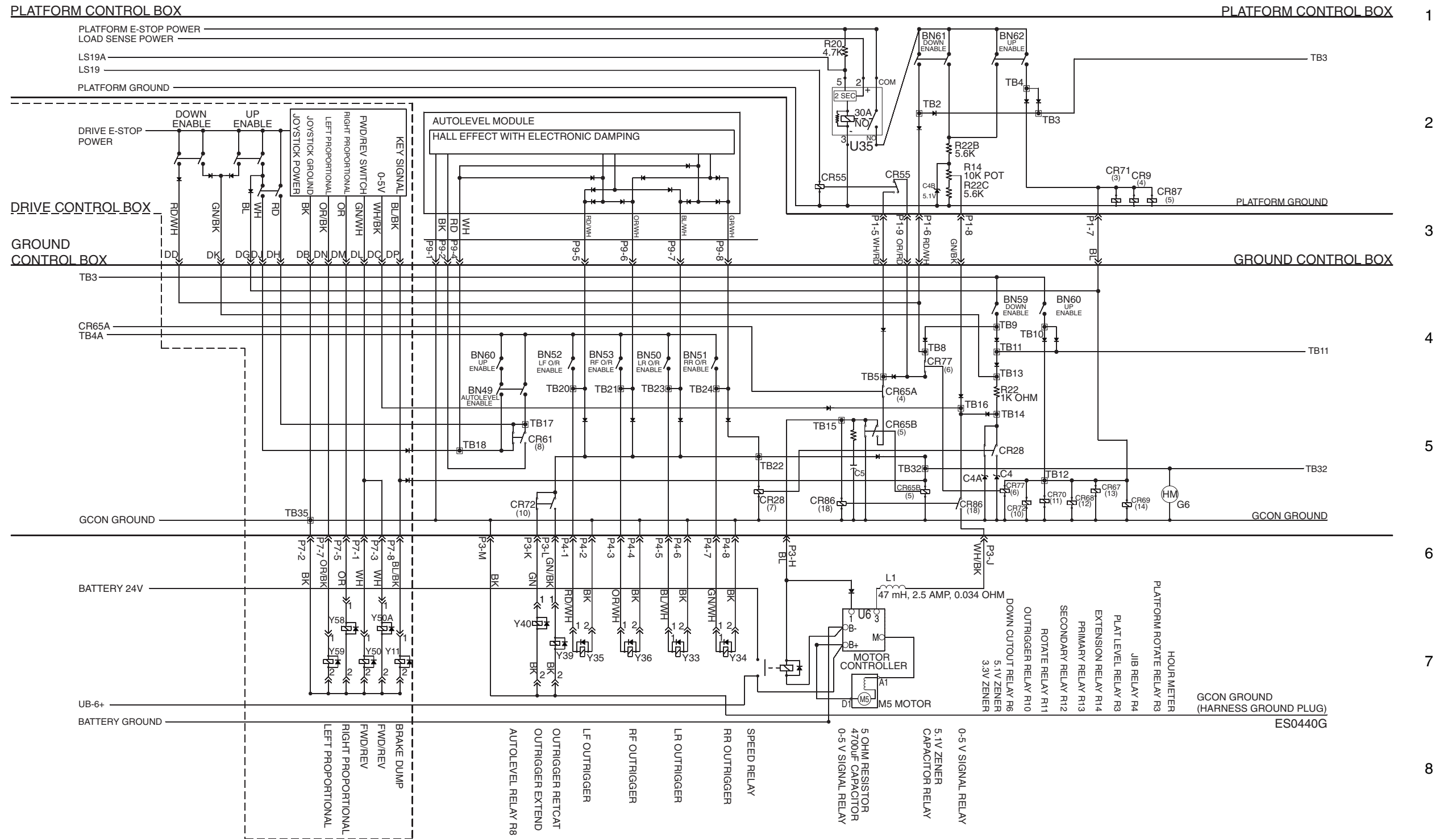

**Electrical Schematic - AS/CE
(from serial number TZ5011-311)**

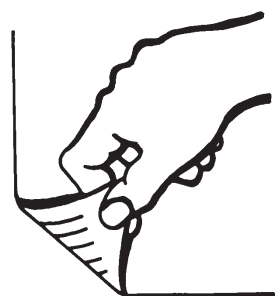

Electrical Schematic - AS/CE, 3 of 3 (from serial number TZ5011-311)

N M L K J I H G F E D C B A

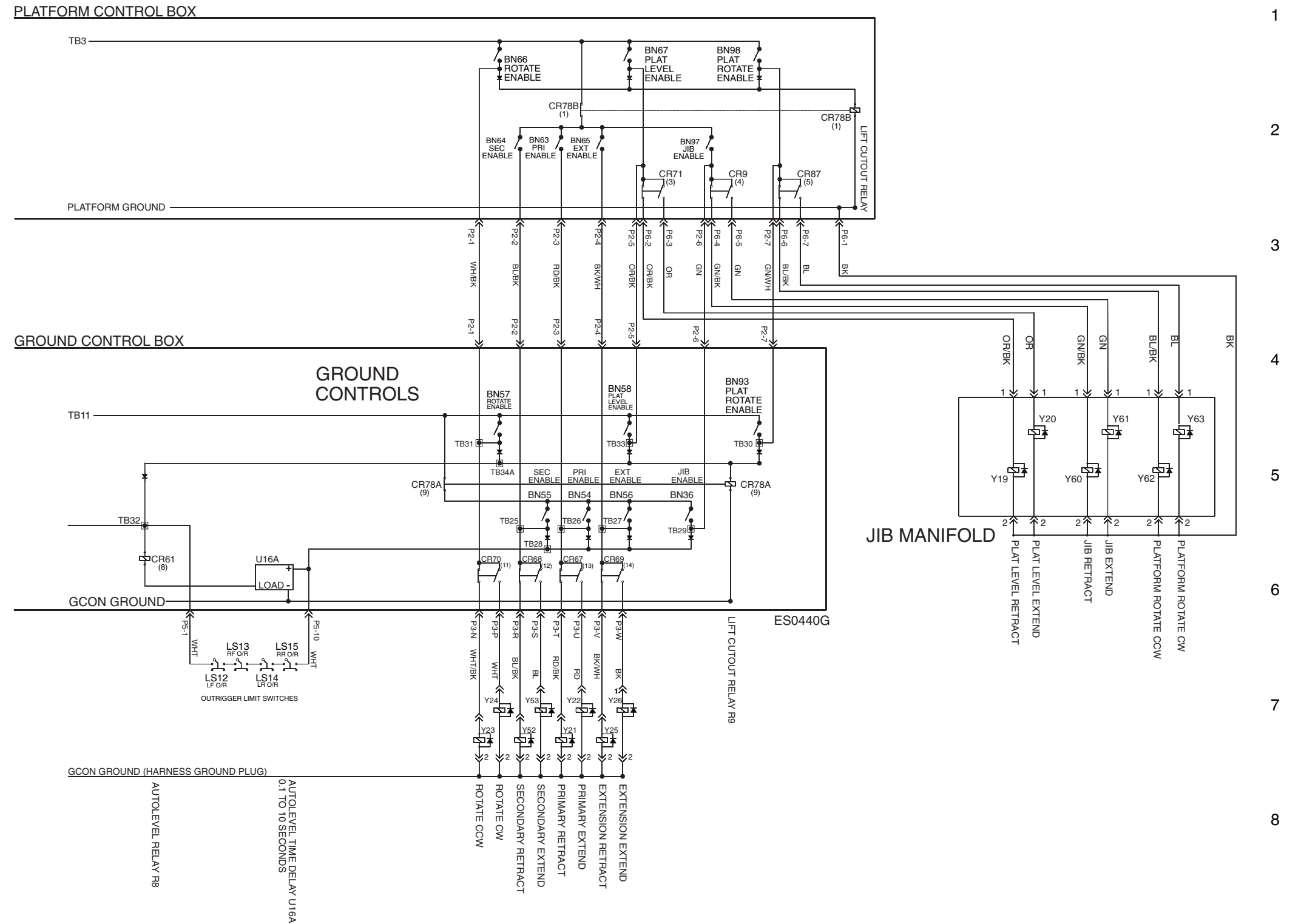

**Electrical Schematic - AS/CE
(from serial number TZ5011-311)**

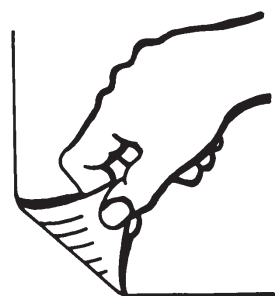

Hydraulic Schematic (to serial number TZ5006-510)



Hydraulic Schematic (to serial number TZ5006-510)

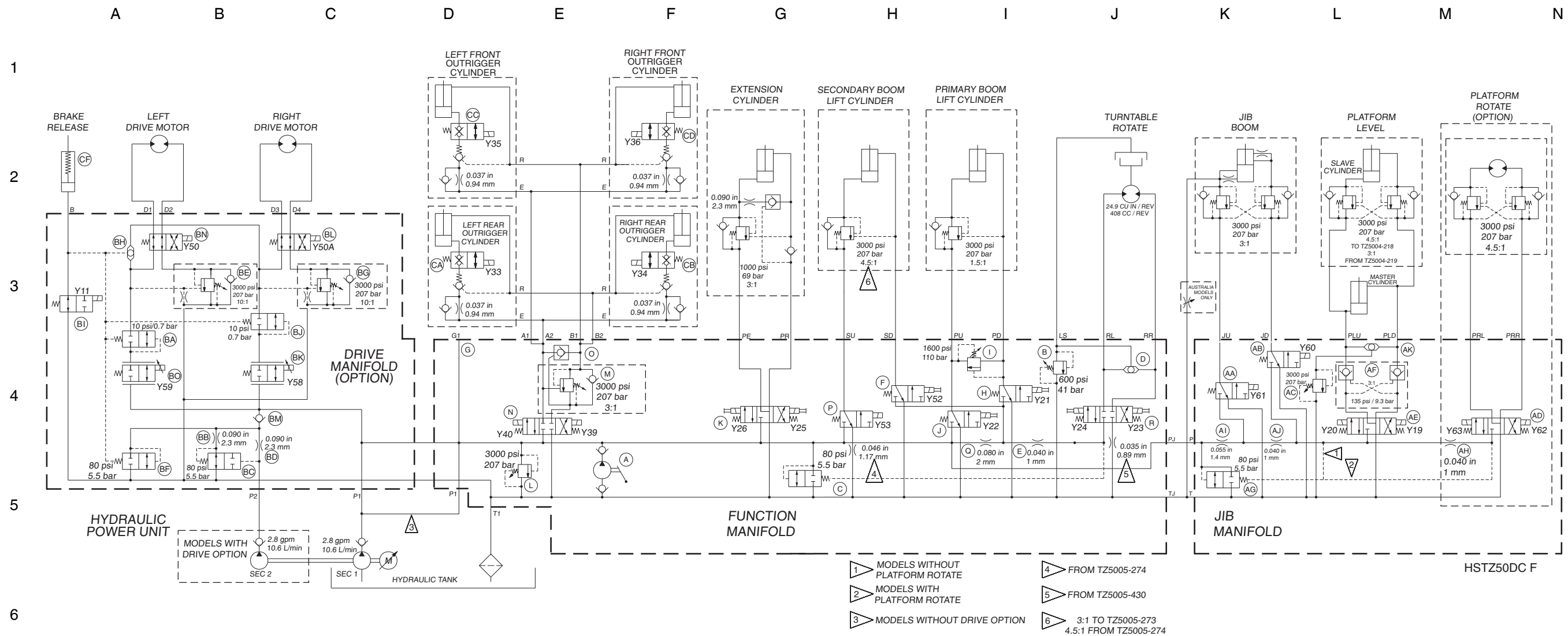

Hydraulic Schematic (from serial number TZ5006-511)

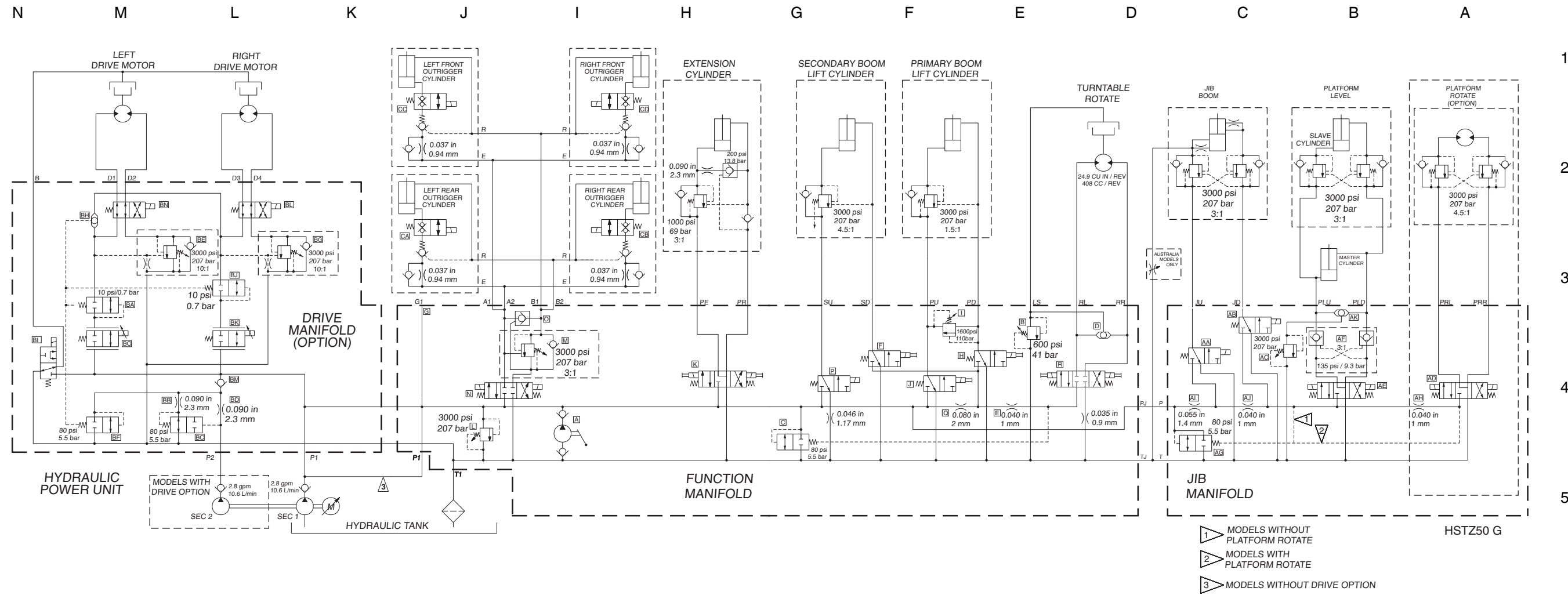

Hydraulic Schematic (from serial number TZ5006-511)

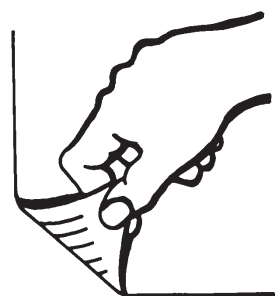

California Proposition 65

Warning

The exhaust from this product contains chemicals known to the State of California to cause cancer, birth defects or other reproductive harm.

Genie North America
Phone 425.881.1800
Toll Free USA and Canada
800.536.1800
Fax 425.883.3475

Genie Australia Pty Ltd.
Phone +61 7 3375 1660
Fax +61 7 3375 1002

Genie China
Phone +86 21 53853768
Fax +86 21 53852569

Genie Singapore
Phone +65 67533544
Fax +65 67533544

Genie Japan
Phone +81 3 6436 2020
Fax +81 3 5445 1231

Genie Korea
Phone +82 2 558 7267
Fax +82 2 558 3910

Genie Brasil
Phone +55 11 4082 5600
Fax +55 22 4082 5630

Genie Holland
Phone +31 183 581 102
Fax +31 183 581 566

Genie Sweden
Phone 0046 3157 5101
Fax 0046 3157 5104

Genie France
Phone 0033 237 260 986
Fax 0033 237 260 998

Genie Iberica
Phone 0034 900 808 110
Fax 0034 935 725 080

Genie Germany
Phone 0800 180 9017
Phone 0049 4221 491 821
Fax 0049 4221 491 820

Genie U.K.
Phone 0044 1476 584 333
Fax 0044 1476 584 330

Genie Mexico City
Phone +52 55 5666 5242
Fax +52 55 5666 3241

Distributed By: