

Genie®



Service Manual

Part No. 52075
Rev C
June 2005

TMZ™-34/19

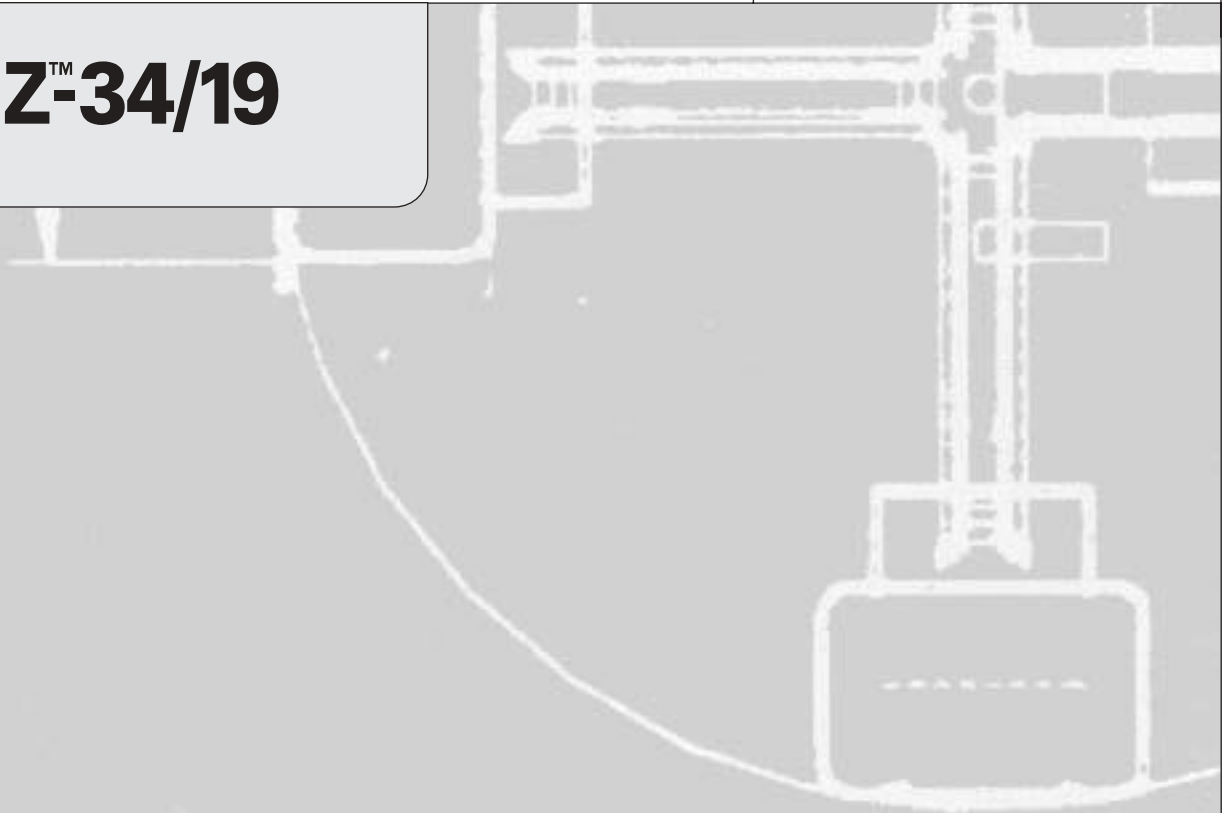

Introduction

Important

Read, understand and obey the safety rules and operating instructions in the appropriate Operator's Manual on your machine before attempting any maintenance or repair procedure.

This manual provides detailed scheduled maintenance information for the machine owner and user. It also provides troubleshooting and repair procedures for qualified service professionals.

Basic mechanical, hydraulic and electrical skills are required to perform most procedures. However, several procedures require specialized skills, tools, lifting equipment and a suitable workshop. In these instances, we strongly recommend that maintenance and repair be performed at an authorized Genie dealer service center.

Technical Publications

Genie Industries has endeavored to deliver the highest degree of accuracy possible. However, continuous improvement of our products is a Genie policy. Therefore, product specifications are subject to change without notice.

Readers are encouraged to notify Genie of errors and send in suggestions for improvement. All communications will be carefully considered for future printings of this and all other manuals.

Contact Us:

PO Box 97030
Redmond, WA 98073-9730 USA

<http://www.genieindustries.com>
e-mail: techsup@genieind.com

Copyright © 1998 by Genie Industries

52075 Rev C June 2005
First Edition, Third Printing

"Genie" is a registered trademark of Genie Industries in the USA and many other countries.
"TMZ" is a trademark of Genie Industries.

 Printed on recycled paper

Printed in U.S.A.

Safety Rules



Danger

Failure to obey the instructions and safety rules in this manual and the appropriate Operator's Manual on your machine will result in death or serious injury.

Many of the hazards identified in the operator's manual are also safety hazards when maintenance and repair procedures are performed.

Do Not Perform Maintenance Unless:

- You are trained and qualified to perform maintenance on this machine.
- You read, understand and obey:
 - manufacturer's instructions and safety rules
 - employer's safety rules and worksite regulations
 - applicable governmental regulations
- You have the appropriate tools, lifting equipment and a suitable workshop.

SAFETY RULES

Personal Safety

Any person working on or around a machine must be aware of all known safety hazards. Personal safety and the continued safe operation of the machine should be your top priority.



Read each procedure thoroughly. This manual and the decals on the machine, use signal words to identify the following:



Safety alert symbol—used to alert personnel to potential personal injury hazards. Obey all safety messages that follow this symbol to avoid possible injury or death.

▲ DANGER

Red—used to indicate the presence of an imminently hazardous situation which, if not avoided, will result in death or serious injury.

▲ WARNING

Orange—used to indicate the presence of a potentially hazardous situation which, if not avoided, could result in death or serious injury.

▲ CAUTION

Yellow with safety alert symbol—used to indicate the presence of a potentially hazardous situation which, if not avoided, may cause minor or moderate injury.

CAUTION

Yellow without safety alert symbol—used to indicate the presence of a potentially hazardous situation which, if not avoided, may result in property damage.

NOTICE

Green—used to indicate operation or maintenance information.



Be sure to wear protective eye wear and other protective clothing if the situation warrants it.



Be aware of potential crushing hazards such as moving parts, free swinging or unsecured components when lifting or placing loads. Always wear approved steel-toed shoes.

Workplace Safety

Be sure to keep sparks, flames and lighted tobacco away from flammable and combustible materials like battery gases and engine fuels. Always have an approved fire extinguisher within easy reach.



Be sure that all tools and working areas are properly maintained and ready for use. Keep work surfaces clean and free of debris that could get into machine components and cause damage.



Be sure that your workshop or work area is properly ventilated and well lit.



Be sure any forklift, overhead crane or other lifting or supporting device is fully capable of supporting and stabilizing the weight to be lifted. Use only chains or straps that are in good condition and of ample capacity.



Be sure that fasteners intended for one time use (i.e., cotter pins and self-locking nuts) are not reused. These components may fail if they are used a second time.



Be sure to properly dispose of old oil or other fluids. Use an approved container. Please be environmentally safe.

Table of Contents

Introduction

Important Information	<i>ii</i>
-----------------------------	-----------

Section 1

Safety Rules

General Safety Rules	<i>iii</i>
----------------------------	------------

Section 2

Rev Specifications

C	Machine Specifications	2 - 1
C	Performance Specifications	2 - 1
C	Hydraulic Specifications	2 - 2
C	Manifold Component Specifications	2 - 3
C	Machine Torque Specifications	2 - 3
C	Hydraulic Hose and Fitting Torque Specifications	2 - 4
C	SAE and Metric Fasteners Torque Charts	2 - 5

Section 3

Rev Scheduled Maintenance Procedures

	Introduction	3 - 1
	Pre-delivery Preparation Report	3 - 3
	Maintenance Inspection Report	3 - 5
C	Checklist A Procedures	
A-1	Perform Pre-operation Inspection	3 - 6
A-2	Perform Function Tests	3 - 6
A-3	Perform Hitch Maintenance - ANSI Models	3 - 7
A-4	Perform Axle Maintenance - ANSI Models	3 - 7
A-5	Perform Axle Maintenance - CE Models	3 - 8
A-6	Perform Axle Maintenance - CE Models	3 - 8
A-7	Perform Axle Maintenance - ANSI Models	3 - 9
A-8	Perform Axle Maintenance - ANSI Models	3 - 9
A-9	Perform Axle Maintenance - CE Models	3 - 10
A-10	Perform 30 Day Service	3 - 10
A-11	Grease the Turntable Rotation Bearing and Rotate Gear	3 - 11

 TABLE OF CONTENTS

Section 3	Rev	Scheduled Maintenance Procedures, continued	
	C	Checklist B Procedures	
		B-1 Inspect the Batteries	3 - 12
		B-2 Inspect the Electrical Wiring	3 - 13
		B-3 Test the Emergency Stop	3 - 14
		B-4 Test the Key Switch	3 - 14
		B-5 Test the Manual Lowering Operation	3 - 15
		B-6 Inspect the Tires and Wheels (including lug nut or lug bolt torque)	3 - 16
		B-7 Service the Tongue Jack	3 - 16
		B-8 Inspect the Parking Brake	3 - 17
		B-9 Test the Horn	3 - 18
		B-10 Test the Flashing Beacon (if equipped)	3 - 18
		B-11 Test the Platform Rotation (if equipped)	3 - 19
		B-12 Inspect the Hydraulic Tank Cap Venting System	3 - 19
		B-13 Perform Hitch Maintenance - ANSI Models	3 - 20
		B-13 Perform Axle Maintenance - ANSI Models	3 - 20
		B-14 Perform Hydraulic Oil Analysis	3 - 21
	C	Checklist C Procedure	
		C-1 Replace the Hydraulic Tank Breather Cap - Models with Optional Hydraulic Oil	3 - 22
		C-2 Perform Axle Maintenance - ANSI Models	3 - 22
		C-3 Perform Hitch Maintenance - CE Models	3 - 23
	C	Checklist D Procedures	
		D-1 Check the Turntable Rotation Bearing Bolts	3 - 24
		D-2 Inspect for Turntable Bearing Wear	3 - 25
		D-3 Replace the Hydraulic Tank Return Filter	3 - 26
		D-4 Perform Axle Maintenance - ANSI Models	3 - 27
		D-5 Perform Hitch Maintenance - ANSI Models	3 - 27
	C	Checklist E Procedure	
		E-1 Test or Replace the Hydraulic Oil	3 - 28

TABLE OF CONTENTS

Section 4	Rev	Repair Procedures	
		Introduction	4 - 1
	C	Platform Controls	
		1-1 Circuit Board	4 - 2
		1-2 Membrane Overlay	4 - 3
	C	Platform Components	
		2-1 Platform	4 - 5
		2-2 Platform Rotator (if equipped)	4 - 5
	C	Jib Boom Components	
		3-1 Jib Boom	4 - 8
		3-2 Jib Boom Lift Cylinder	4 - 10
	B	Boom Components	
		4-1 Boom	4 - 12
		4-2 Lift Cylinders	4 - 18
	C	Ground Controls	
		5-1 Ground Control Keypad Circuit Board	4 - 20
		5-2 CPU Circuit Board	4 - 22
		5-3 Connector Circuit Board	4 - 22
		5-4 Software Configuration	4 - 23
		5-5 Membrane Overlay	4 - 25
		5-6 Level Sensor	4 - 27
		5-7 Interacter BatteryCharger	4 - 30
		5-8 Lester Battery Charger	4 - 32
	B	Hydraulic Power Unit	
		6-1 Hydraulic Power Unit Components	4 - 34
		6-2 Valve Adjustments - Hydraulic Power Unit	4 - 36
		6-3 Hydraulic Pump	4 - 37

 TABLE OF CONTENTS

Section 4	Rev	Repair, continued	
	C	Manifolds	
		7-1 Turntable Rotation Manifold Components	4 - 40
		7-2 Valve Adjustments - Turntable Rotation Manifold	4 - 41
		7-3 Outrigger Manifold Components	4 - 42
		7-4 Valve Coils	4 - 43
	B	Turntable Rotation Components	
		8-1 Turntable Rotation Motor	4 - 45
	B	Axle Components	
		9-1 Axle	4 - 46
		9-2 Hub and Bearings	4 - 46
	C	Trailer Components	
		10-1 Trailer Brakes	4 - 47
		10-2 Parking Brake	4 - 47
	B	Outriggers	
		11-1 Outrigger Components	4 - 48
		11-2 Outrigger Cylinder	4 - 49

TABLE OF CONTENTS

Section 5	Rev	Troubleshooting Flow Charts		
		Introduction		5 - 1
	A	Fault Code Chart (after serial number T3402-115)		5 - 3
		Chart Number	Chart Title	
	B	1	All Functions Will Not Operate (before serial number T3400-001)	5 - 6
	B	2	Pump Motor Will Not Operate	5 - 8
	B	3	All Functions Inoperative, Power Unit Starts and Runs	5 - 9
	B	4	Ground Controls Inoperative	5 - 10
	B	5	Platform Controls Inoperative	5 - 11
	B	6	Jib Boom Up Function Inoperative	5 - 12
	B	7	Jib Boom Down Function Inoperative	5 - 13
	B	8	Primary Boom Up Function Inoperative	5 - 15
	B	9	Primary Boom Down Function Inoperative	5 - 16
	B	10	Secondary Boom Up Function Inoperative	5 - 18
	B	11	Secondary Boom Down Function Inoperative	5 - 19
	B	12	Turntable Rotate Left Function Inoperative	5 - 21
	B	13	Turntable Rotate Right Function Inoperative	5 - 22
	A	14	Parking Brake Function Inoperative	5 - 23

 TABLE OF CONTENTS

Section 6	Rev	Schematics	
		Introduction	6 - 1
	B	Electrical Component and Wire Color Legends	6 - 2
	A	Limit Switch Legend	6 - 3
	A	Trailer Lighting Wiring Diagram	6 - 4
	A	Electrical Symbols Legend	6 - 5
	B	Electrical Schematic - Models with Manual Outriggers (from serial number T3498-001 to T3499-361)	6 - 6
	A	Electrical Schematic - Models with Manual Outriggers (from serial number T3499-362 to T3499-769)	6 - 7
	B	Electrical Schematic - Models with Manual Outriggers (from serial number T3400-001)	6 - 8
	B	Electrical Schematic - Models with Hydraulic Outriggers	6 - 10
	A	Hydraulic Symbols Legend and Component Reference	6 - 13
	A	Hydraulic Schematic - Models with Manual Outriggers (from serial number T3498-001 to T3499-769)	6 - 14
	A	Hydraulic Schematic - Models with Manual Outriggers (from serial number T3400-001 to T3400-265)	6 - 15
	A	Hydraulic Schematic - Models with Manual Outriggers (after serial number T3400-265)	6 - 16
	A	Hydraulic Schematic - Models with Hydraulic Outriggers (before serial number T3400-266)	6 - 14
	A	Hydraulic Schematic - Models with Hydraulic Outriggers (after serial number T3400-265)	6 - 15

Specifications

REV C

Machine Specifications

Batteries

Type	6V DC
Group	T-105
Quantity	4
Battery capacity	225AH
Reserve capacity @ 25A rate	447 minutes

Fluid capacities

Hydraulic tank capacity	1.5 gallons 5.7 liters
Hydraulic system capacity (including tank)	2.25 gallons 8.5 liters

Tires and wheels - ANSI, CSA

Tire size	ST195/75-D14
Wheel lugs	5 @ 1/2 -20
Lug nut torque, dry	90 to 120 ft-lbs 122 to 162 Nm
Tire pressure (cold)	65 psi 4.5 bar

Tires and wheels - CE

Tire size	195/65R15 91T
Wheel lugs	5 @ 1/2 -20
Lug nut torque, dry	90 to 120 ft-lbs 122 to 162 Nm
Tire pressure (cold)	44 psi 3 bar

Tongue jack jockey wheels

Tire size - pneumatic tire	4.00 / 3.50-4
Diameter	10 in 25.4 cm
Tire pressure, maximum (cold)	50 psi 3.4 bar

Performance Specifications

Boom function speeds, maximum from ground controls (no weight in platform)

Jib boom up	10 to 15 seconds
Jib boom down	13 to 18 seconds
Primary boom up	30 to 35 seconds
Primary boom down	21 to 26 seconds
Secondary boom up	15 to 20 seconds
Secondary boom down	13 to 18 seconds
Turntable rotate, 358 °	55 to 60 seconds
Airborne noise emissions Maximum sound level at normal operating workstations (A-weighted)	70 dB

For operational specifications, refer to the Operator's Manual.

Continuous improvement of our products is a Genie policy. Product specifications are subject to change without notice or obligation.

SPECIFICATIONS

REV C

Hydraulic Specifications**Hydraulic Oil Specifications**

From serial number T3498-001 to T3402-375
 Hydraulic oil type Shell Donax TG (Dexron III)

After serial number T3402-375
 Hydraulic oil type Chevron Rykon MV equivalent
 Approximate SAE grade 5W-20
 Viscosity index rating 200

Chevron Rykon MV oil is fully compatible and mixable with Shell Donax TG (Dexron III) oils.
 Genie specifications require hydraulic oils which are designed to give maximum protection to hydraulic systems, have the ability to perform over a wide temperature range, and have a minimum viscosity index rating of 150. They should provide excellent antiwear, oxidation, corrosion inhibition, seal conditioning, and foam and aeration suppression properties.

Optional fluids

Biodegradable Petro Canada Premium ECO 46
 Statoil Hydra Way Bio Pa 32
 BP Biohyd SE-S

Fire resistant UCON Hydrolube HP-5046
 Quintolubric 822

Mineral based Shell Tellus T32
 Shell Tellus T46
 Chevron Aviation A

NOTICE Use Chevron Aviation A hydraulic oil when in ambient temperatures consistently below 0°F / -17°C.

NOTICE Use Shell Tellus T46 hydraulic oil when oil temperatures consistently exceed 205°F / 96°C.

NOTICE Genie specifications require additional equipment and special installation instructions for the approved optional fluids. Consult the Genie Industries Service Department before use.

Continuous improvement of our products is a Genie policy. Product specifications are subject to change without notice or obligation.

Hydraulic power unit

Pump type: Gear

Displacement 0.057 cu in
 per revolution 0.93 cc

Flow rate @ 3000 psi / 207 bar 1.5 gpm
 5.7 L/min

System relief valve pressure 3200 psi
 220.6 bar

Hydraulic tank 10 micron with
 return filter 18 psi / 1.2 bar bypass

Turntable rotate manifold

Relief valve pressure 1200 psi
 82.7 bar

REV C

SPECIFICATIONS

Manifold Component Specifications

Plug torque

SAE No. 2	50 in-lbs / 6 Nm
SAE No. 4	13 ft-lbs / 18 Nm
SAE No. 6	18 ft-lbs / 24 Nm
SAE No. 8	50 ft-lbs / 68 Nm
SAE No. 10	55 ft-lbs / 75 Nm
SAE No. 12	75 ft-lbs / 102 Nm

Valve coil resistance

Description	Specification
Solenoid valve, 2 position 2 way 24V DC (schematic items A, B and C)	29 - 31 Ω
Proportional solenoid valve, N.C. 24V DC (schematic item E)	31.5 to 33.5 Ω
Solenoid valve, 3 position 4 way N.C. 20V DC (schematic item H)	23 to 25 Ω
Solenoid valve, 2 position 3 way 20V DC (schematic item K)	23 to 25 Ω
Solenoid valve, 3 position 4 way N.C. 20V DC (schematic item L)	23 to 25 Ω
Solenoid valve, 2 position 2 way 24V DC (schematic items M, N, O and P)	29 - 31 Ω

Machine Torque Specifications

Turntable rotate motor

M12 bolts, dry	60 ft-lbs 81 Nm
----------------	--------------------

Continuous improvement of our products is a Genie policy. Product specifications are subject to change without notice or obligation.



SPECIFICATIONS

REV C

Hydraulic Hose and Fitting Torque Specifications

Your machine is equipped with Parker Seal-Lok® fittings and hose ends. Genie specifications require that fittings and hose ends be torqued to specification when they are removed and installed or when new hoses or fittings are installed.

SAE O-ring Boss Port

(tube fitting - installed into Aluminum)

SAE Dash size	Torque
-4	11 ft-lbs / 14.9 Nm
-6	23 ft-lbs / 31.2 Nm
-8	40 ft-lbs / 54.2 Nm
-10	69 ft-lbs / 93.6 Nm
-12	93 ft-lbs / 126.1 Nm
-16	139 ft-lbs / 188.5 Nm
-20	172 ft-lbs / 233.2 Nm
-24	208 ft-lbs / 282 Nm

SAE O-ring Boss Port

(tube fitting - installed into Steel)

SAE Dash size	Torque
-4	16 ft-lbs / 21.7 Nm
-6	35 ft-lbs / 47.5 Nm
-8	60 ft-lbs / 81.3 Nm
-10	105 ft-lbs / 142.4 Nm
-12	140 ft-lbs / 190 Nm
-16	210 ft-lbs / 284.7 Nm
-20	260 ft-lbs / 352.5 Nm
-24	315 ft-lbs / 427.1 Nm

Seal-Lok® fittings

- 1 Replace the O-ring. The O-ring must be replaced anytime the seal has been broken. The O-ring cannot be re-used if the fitting or hose end has been tightened beyond finger tight.

NOTICE

The O-rings used in the Parker Seal Lok® fittings and hose ends are custom-size O-rings. They are not standard SAE size O-rings. They are available in the O-ring field service kit (Genie part number 49612).

- 2 Lubricate the O-ring before installation.
- 3 Be sure that the face seal O-ring is seated and retained properly.
- 4 Position the tube and nut squarely on the face seal end of the fitting and tighten the nut finger tight.
- 5 Tighten the nut or fitting to the appropriate torque per given size as shown in the table.
- 6 Operate all machine functions and inspect the hoses and fittings and related components to confirm that there are no leaks.



Seal-Lok® Fittings





(hose end)

SAE Dash size	Torque
-4	18 ft-lbs / 24.4 Nm
-6	27 ft-lbs / 36.6 Nm
-8	40 ft-lbs / 54.2 Nm
-10	63 ft-lbs / 85.4 Nm
-12	90 ft-lbs / 122 Nm
-16	120 ft-lbs / 162.7 Nm
-20	140 ft-lbs / 190 Nm
-24	165 ft-lbs / 223.7 Nm

REV C

SPECIFICATIONS

SAE FASTENER TORQUE CHART											
• This chart is to be used as a guide only unless noted elsewhere in this manual •											
SIZE	THREAD	Grade 5 				Grade 8 				A574 High Strength Black Oxide Bolts	
		LUBED		DRY		LUBED		DRY		LUBED	
		in-lbs	Nm	in-lbs	Nm	in-lbs	Nm	in-lbs	Nm	in-lbs	Nm
1/4	20	100	11.3	80	9	140	15.8	110	12.4	130	14.7
	28	90	10.1	120	13.5	120	13.5	160	18	140	15.8
		LUBED		DRY		LUBED		DRY		LUBED	
		ft-lbs	Nm	ft-lbs	Nm	ft-lbs	Nm	ft-lbs	Nm	ft-lbs	Nm
5/16	18	13	17.6	17	23	18	24	25	33.9	21	28.4
	24	14	19	19	25.7	20	27.1	27	36.6	24	32.5
3/8	16	23	31.2	31	42	33	44.7	44	59.6	38	51.5
	24	26	35.2	35	47.4	37	50.1	49	66.4	43	58.3
7/16	14	37	50.1	49	66.4	50	67.8	70	94.7	61	82.7
	20	41	55.5	55	74.5	60	81.3	80	108.4	68	92.1
1/2	13	57	77.3	75	101.6	80	108.4	110	149	93	126
	20	64	86.7	85	115	90	122	120	162	105	142
9/16	12	80	108.4	110	149	120	162	150	203	130	176
	18	90	122	120	162	130	176	170	230	140	189
5/8	11	110	149	150	203	160	217	210	284	180	244
	18	130	176	170	230	180	244	240	325	200	271
3/4	10	200	271	270	366	280	379	380	515	320	433
	16	220	298	300	406	310	420	420	569	350	474
7/8	9	320	433	430	583	450	610	610	827	510	691
	14	350	474	470	637	500	678	670	908	560	759
1	8	480	650	640	867	680	922	910	1233	770	1044
	12	530	718	710	962	750	1016	990	1342	840	1139
1 1/8	7	590	800	790	1071	970	1315	1290	1749	1090	1477
	12	670	908	890	1206	1080	1464	1440	1952	1220	1654
1 1/4	7	840	1138	1120	1518	1360	1844	1820	2467	1530	2074
	12	930	1260	1240	1681	1510	2047	2010	2725	1700	2304
1 1/2	6	1460	1979	1950	2643	2370	3213	3160	4284	2670	3620
	12	1640	2223	2190	2969	2670	3620	3560	4826	3000	4067

METRIC FASTENER TORQUE CHART																
• This chart is to be used as a guide only unless noted elsewhere in this manual •																
Size (mm)	Class 4.6 				Class 8.8 				Class 10.9 				Class 12.9 			
	LUBED		DRY		LUBED		DRY		LUBED		DRY		LUBED		DRY	
	in-lbs	Nm	in-lbs	Nm	in-lbs	Nm	in-lbs	Nm	in-lbs	Nm	in-lbs	Nm	in-lbs	Nm	in-lbs	Nm
5	16	1.8	21	2.4	41	4.63	54	6.18	58	6.63	78	8.84	68	7.75	91	10.3
6	19	3.05	36	4.07	69	7.87	93	10.5	100	11.3	132	15	116	13.2	155	17.6
7	45	5.12	60	6.83	116	13.2	155	17.6	167	18.9	223	25.2	1.95	22.1	260	29.4
	LUBED		DRY		LUBED		DRY		LUBED		DRY		LUBED		DRY	
	ft-lbs	Nm	ft-lbs	Nm	ft-lbs	Nm	ft-lbs	Nm	ft-lbs	Nm	ft-lbs	Nm	ft-lbs	Nm	ft-lbs	Nm
8	5.4	7.41	7.2	9.88	14	19.1	18.8	25.5	20.1	27.3	26.9	36.5	23.6	32	31.4	42.6
10	10.8	14.7	14.4	19.6	27.9	37.8	37.2	50.5	39.9	54.1	53.2	72.2	46.7	63.3	62.3	84.4
12	18.9	25.6	25.1	34.1	48.6	66	64.9	88	69.7	94.5	92.2	125	81	110	108	147
14	30.1	40.8	40	54.3	77.4	105	103	140	110	150	147	200	129	175	172	234
16	46.9	63.6	62.5	84.8	125	170	166	226	173	235	230	313	202	274	269	365
18	64.5	87.5	86.2	117	171	233	229	311	238	323	317	430	278	377	371	503
20	91	124	121	165	243	330	325	441	337	458	450	610	394	535	525	713
22	124	169	166	225	331	450	442	600	458	622	612	830	536	727	715	970
24	157	214	210	285	420	570	562	762	583	791	778	1055	682	925	909	1233



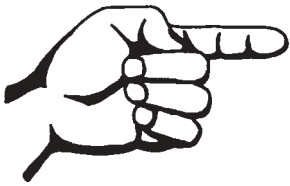

This page intentionally left blank.

Scheduled Maintenance Procedures



Observe and Obey:

- ☑ Maintenance inspections shall be completed by a person trained and qualified on the maintenance of this machine.
- ☑ Scheduled maintenance inspections shall be completed daily, quarterly and semi-annually as specified on the *Maintenance Inspection Report*.

AWARNING Failure to perform each procedure as presented and scheduled could result in death, serious injury or substantial damage.

- ☑ Immediately tag and remove from service a damaged or malfunctioning machine.
- ☑ Repair any machine damage or malfunction before operating the machine.
- ☑ Keep records on all inspections for three years.
- ☑ Machines that have been out of service for a period longer than 3 months must complete the quarterly inspection.
- ☑ Unless otherwise specified, perform each maintenance procedure with the machine in the following configuration:
 - Machine disconnected from tow vehicle
 - Machine parked on a firm, level surface with the boom stowed and both latches secured
 - Key switch in the off position with the key removed
 - The red Emergency Stop button in the off position at both ground and platform controls
 - Wheels chocked and parking brake applied
 - All external AC power supply disconnected from the machine

About This Section

This section contains detailed procedures for each scheduled maintenance inspection.

Each procedure includes a description, safety warnings and step-by-step instructions.

Symbols Legend



Safety alert symbol—used to alert personnel to potential personal injury hazards. Obey all safety messages that follow this symbol to avoid possible injury or death.



Red—used to indicate the presence of an imminently hazardous situation which, if not avoided, will result in death or serious injury.



Orange—used to indicate the presence of a potentially hazardous situation which, if not avoided, could result in death or serious injury.



Yellow with safety alert symbol—used to indicate the presence of a potentially hazardous situation which, if not avoided, may cause minor or moderate injury.



Yellow without safety alert symbol—used to indicate the presence of a potentially hazardous situation which, if not avoided, may result in property damage.



Green—used to indicate operation or maintenance information.

- ⦿ Indicates that a specific result is expected after performing a series of steps.
- ⊗ Indicates that an incorrect result has occurred after performing a series of steps.

SCHEDULED MAINTENANCE PROCEDURES

Maintenance Symbols Legend**NOTICE**

The following symbols have been used in this manual to help communicate the intent of the instructions. When one or more of the symbols appears at the beginning of a maintenance procedure, it conveys the meaning below.



Indicates that tools will be required to perform this procedure.



Indicates that new parts will be required to perform this procedure.



Indicates that a cold motor or pump will be required to perform this procedure.



Indicates that dealer service will be required to perform this procedure.

Pre-delivery Preparation Report

The pre-delivery preparation report contains checklists for each type of scheduled inspection.

Make copies of the *Pre-delivery Preparation* report to use for each inspection. Store completed forms as required.

Maintenance Schedule

There are five types of maintenance inspections that must be performed according to a schedule—daily, quarterly, semi-annually, annually, and two year. The *Scheduled Maintenance Procedures Section and the Maintenance Inspection Report* have been divided into five subsections—A, B, C, D, and E. Use the following chart to determine which group(s) of procedures are required to perform a scheduled inspection.

Inspection	Checklist
Daily or every 8 hours	A
Quarterly or every 250 hours or every 3000 miles	A + B
Semi-annually or every 500 hours or every 6000 miles	A + B + C
Annually or every 1000 hours or every 12000 miles	A + B + C + D
Two year or every 2000 hours	A + B + C + D + E

Maintenance Inspection Report

The maintenance inspection report contains checklists for each type of scheduled inspection.

Make copies of the *Maintenance Inspection Report* to use for each inspection. Store completed forms for three years.

Pre-Delivery Preparation

Fundamentals

It is the responsibility of the dealer to perform the Pre-delivery Preparation.

The Pre-delivery Preparation is performed prior to each delivery. The inspection is designed to discover if anything is apparently wrong with a machine before it is put into service.

A damaged or modified machine must never be used. If damage or any variation from factory delivered condition is discovered, the machine must be tagged and removed from service.

Repairs to the machine may only be made by a qualified service technician, according to the manufacturer's specifications.

Scheduled maintenance inspections shall be performed by qualified service technicians, according to the manufacturer's specifications and the requirements listed in the responsibilities manual.

Instructions

Use the operator's manual on your machine.

The Pre-delivery Preparation consists of completing the Pre-operation Inspection, the Maintenance items and the Function Tests.

Use this form to record the results. Place a check in the appropriate box after each part is completed. Follow the instructions in the operator's manual.

If any inspection receives an N, remove the machine from service, repair and re-inspect it. After repair, place a check in the R box.

Legend

Y = yes, completed

N = no, unable to complete

R = repaired

Comments

Pre-Delivery Preparation	Y	N	R
Pre-operation inspection completed			
Maintenance items completed			
Function tests completed			

Model

Serial number

Date

Machine owner

Inspected by (print)

Inspector signature

Inspector title

Inspector company



Genie Industries USA
18340 NE 76th Street
PO Box 97030
Redmond, WA 98073-9730
(425) 881-1800

Genie UK
The Maltings, Wharf Road
Grantham, Lincolnshire
NG31- 6BH England
(44) 1476-584333

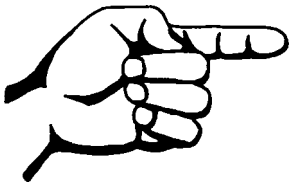

This page intentionally left blank.

Maintenance Inspection Report

Model
Serial number
Date
Hour meter
Machine owner
Inspected by (print)
Inspector signature
Inspector title
Inspector company

- Instructions**
- Make copies of this report to use for each inspection.
 - Select the appropriate checklist(s) for the type of inspection to be performed.

<input type="checkbox"/>	Daily or 8 hours Inspection:	A
<input type="checkbox"/>	Quarterly or 250 hours or 3000 mile Inspection:	A+B
<input type="checkbox"/>	Semi-annually or 500 hours or 6000 mile Inspection:	A+B+C
<input type="checkbox"/>	Annually or 1000 hours or 12000 mile Inspection:	A+B+C+D
<input type="checkbox"/>	Two year or 2000 hours Inspection:	A+B+C+D+E

- Place a check in the appropriate box after each inspection procedure is completed.
- Use the step-by-step procedures in this section to learn how to perform these inspections.
- If any inspection receives an "N", tag and remove the machine from service, repair and re-inspect it. After repair, place a check in the "R" box.

Legend
 Y = yes, acceptable
 N = no, remove from service
 R = repaired

Comments

Checklist A - Rev C		Y	N	R
A-1	Pre-operation inspect			
A-2	Function tests			
A-3	Hitch maintenance - ANSI models			
A-4	Axle maintenance - ANSI models			
A-5	Axle maintenance - CE models			
Perform after 100 km:				
A-6	Axle maintenance - CE models			
Perform after 200 miles:				
A-7	Axle maintenance - ANSI models			
Perform weekly:				
A-8	Axle maintenance - ANSI models			
Perform after 500 km:				
A-9	Axle maintenance - CE models			
Perform after 40 hours:				
A-10	30 day service			
Perform every 100 hours:				
A-11	Grease rotation bearing			

Checklist B - Rev C		Y	N	R
B-1	Batteries			
B-2	Electrical wiring			
B-3	Emergency Stop			
B-4	Key switch			
B-5	Manual operation			
B-6	Tires and wheels			
B-7	Tongue jack			
B-8	Parking brake			
B-9	Horn			
B-10	Flashing beacon (if equipped)			
B-11	Platform rotation (if equipped)			
B-12	Tank venting system			
B-13	Hitch maintenance - ANSI models			
B-14	Axle maintenance - ANSI models			
B-15	Hydraulic oil analysis			

Checklist C - Rev C		Y	N	R
C-1	Breather cap - models with optional oil			
C-2	Axle maintenance - ANSI models			
C-3	Hitch maintenance - CE models			

Checklist D - Rev C		Y	N	R
D-1	Turntable bearing bolts			
D-2	Turntable bearing wear			
D-3	Hydraulic filter			
D-4	Axle maintenance - ANSI models			
D-5	Hitch maintenance - ANSI models			

Checklist E - Rev C		Y	N	R
E-1	Hydraulic oil			



Checklist A Procedures

REV C

A-1 Perform Pre-operation Inspection



Completing a pre-operation inspection is essential to safe machine operation. The pre-operation inspection is a visual inspection performed by the operator prior to each work shift. The inspection is designed to discover if anything is apparently wrong with a machine before the operator performs the function tests. The pre-operation inspection also serves to determine if routine maintenance procedures are required.

Complete information to perform this procedure is available in the appropriate operator's manual. Refer to the Operator's Manual on your machine.

A-2 Perform Function Tests



Completing the function tests is essential to safe machine operation. Function tests are designed to discover any malfunctions before the machine is put into service. A malfunctioning machine must never be used. If malfunctions are discovered, the machine must be tagged and removed from service.

Complete information to perform this procedure is available in the appropriate operator's manual. Refer to the Operator's Manual on your machine.

REV C

CHECKLIST A PROCEDURES

A-3 Perform Hitch Maintenance - ANSI Models



NOTICE Hitch specifications require that this procedure be performed daily.

Proper hitch maintenance, following the hitch manufacturer's maintenance schedule, is essential to good hitch performance and service life. Failure to perform the maintenance procedures can lead to poor hitch performance and component damage.

Required maintenance procedures and additional hitch information is available in the *Atwood Model MPD84132 Surge Brake System Operation/Maintenance Manual* (Atwood part number MPD85778) OR the *Demco Model 91 Brake Actuators Owner/Operator Manual* (Demco part number BH20023).

Atwood Model MPD84132 Owner/Operator Manual
Genie part number 97403

Demco Model 91 Owner/Operator Manual
Genie part number 84592

A-4 Perform Axle Maintenance - ANSI Models



NOTICE Axle specifications require that this procedure be performed, initially and following a wheel change, after the first 10, 25 and 50 miles.

Proper axle maintenance, following the axle manufacturer's maintenance schedule, is essential to good axle performance and service life. Failure to perform the maintenance procedures can lead to poor axle performance and component damage.

Required maintenance procedures and additional axle information is available in the *Dexter Axle Operation Maintenance Service Manual* (Dexter part number LIT-001-00).

Dexter Axle Operation Maintenance Service Manual
Genie part number 84376

**A-5
Perform Axle Maintenance -
CE Models**



NOTICE Axle specifications require that this procedure be performed initially after the first 50 km, or 50 km after a wheel change.

Proper axle maintenance, following the axle manufacturer's maintenance schedule, is essential to good axle performance and service life. Failure to perform the maintenance procedures can lead to poor axle performance and component damage.

Required maintenance procedures and additional axle information is available in the *Knott Axle Service Manual* (Knott part number P005).

Knott Axle Service Manual	
Genie part number	84443

**A-6
Perform Axle Maintenance -
CE Models**



NOTICE Axle specifications require that this procedure be performed initially after the first 100 km.

Proper axle maintenance, following the axle manufacturer's maintenance schedule, is essential to good axle performance and service life. Failure to perform the maintenance procedures can lead to poor axle performance and component damage.

Required maintenance procedures and additional axle information is available in the *Knott Axle Service Manual* (Knott part number P005).

Knott Axle Service Manual	
Genie part number	84443

REV C

CHECKLIST A PROCEDURES

A-7
Perform Axle Maintenance -
ANSI Models



NOTICE Axle specifications require that this procedure be performed initially at 200 miles.

Proper axle maintenance, following the axle manufacturer's maintenance schedule, is essential to good axle performance and service life. Failure to perform the maintenance procedures can lead to poor axle performance and component damage.

Required maintenance procedures and additional axle information is available in the *Dexter Axle Operation Maintenance Service Manual* (Dexter part number LIT-001-00).

Dexter Axle Operation Maintenance Service Manual
 Genie part number 84376

A-8
Perform Axle Maintenance -
ANSI Models



NOTICE Axle specifications require that this procedure be performed weekly.

Proper axle maintenance, following the axle manufacturer's maintenance schedule, is essential to good axle performance and service life. Failure to perform the maintenance procedures can lead to poor axle performance and component damage.

Required maintenance procedures and additional axle information is available in the *Dexter Axle Operation Maintenance Service Manual* (Dexter part number LIT-001-00).

Dexter Axle Operation Maintenance Service Manual
 Genie part number 84376

A-9 Perform Axle Maintenance - CE Models



NOTICE

Axle specifications require that this procedure be performed 500 km after regreasing the wheel bearings.

Proper axle maintenance, following the axle manufacturer's maintenance schedule, is essential to good axle performance and service life. Failure to perform the maintenance procedures can lead to poor axle performance and component damage.

Required maintenance procedures and additional axle information is available in the *Knott Axle Service Manual* (Knott part number P005).

Knott Axle Service Manual

Genie part number

84443

A-10 Perform 30 Day Service



The 30 day maintenance procedure is a one-time procedure to be performed after the first 30 days or 40 hours of usage. After this interval, refer to the maintenance tables for continued scheduled maintenance.

1 Perform the following maintenance procedures:

- A-11 Grease the Turntable Rotation Bearing and Rotate Gear
- B-8 Inspect the Parking Brake
- D-1 Check the Turntable Rotation Bearing Bolts
- D-3 Replace the Hydraulic Tank Return Filter

REV C

CHECKLIST A PROCEDURES

A-11 Grease the Turntable Rotation Bearing and Rotate Gear



NOTICE Genie specifications require that this procedure be performed every 100 hours of operation.

Regular application of lubrication to the turntable bearing and rotate gear is essential to good machine performance and service life. Continued use of an insufficiently greased bearing and gear will result in component damage.

- 1 Locate the grease fitting on the inside of the turntable rotation bearing.

NOTICE The grease fitting is best located through the bulkhead opening behind the ground control box.

- 2 Pump grease into the turntable rotation bearing. Rotate the turntable in increments of 4 to 5 inches / 10 to 13 cm at a time and repeat this step until the entire bearing has been greased.
- 3 Apply grease to each tooth of the drive gear located under the turntable.

Grease Specification

Chevron Ultra-duty grease, EP NLGI 2 (lithium based) or equivalent

Checklist B Procedures

REV C

B-1

Inspect the Batteries



Proper battery condition is essential to good machine performance and operational safety. A faulty battery cell can result in poor machine performance and improper fluid levels or damaged cables and connections can result in component damage and hazardous conditions.

⚠ WARNING Bodily injury hazard. Batteries contain acid. Avoid spilling or contacting battery acid. Neutralize battery acid spills with baking soda and water.

⚠ WARNING Electrocutation hazard. Contact with hot or live circuits could result in death or serious injury. Remove all rings, watches and other jewelry.

NOTICE Perform this test after fully charging the battery.

NOTICE For a more accurate determination of battery condition, fully charge the batteries and allow the batteries to rest for 24 hours before performing this procedure. This will allow the battery cells to equalize.

- 1 Put on protective clothing and eye wear.
- 2 Be sure that the battery cable connections are tight and free of corrosion.
- 3 Be sure that the battery retaining fasteners are in place and secure.
- 4 Remove the battery vent caps from all batteries and check the specific gravity of each battery cell with a hydrometer.
 - ⦿ Result: If any battery cell displays a specific gravity of less than 1.026, the battery must be replaced.
- 5 Check the battery acid level of each battery. If needed, replenish with distilled water to the bottom of each battery fill tube. Do not overfill.
- 6 Install the battery vent caps.
- 7 Check each battery pack and verify that the batteries are wired correctly. Refer to the *Battery Connection Diagram* decal on the machine.
- 8 Inspect the battery charger plug and pigtail for damage or excessive insulation wear. Replace as required.

REV C

CHECKLIST B PROCEDURES

B-2 Inspect the Electrical Wiring



Maintaining electrical wiring in good condition is essential to safe operation and good machine performance. Failure to find and replace burnt, chafed, corroded or pinched wires could result in unsafe operating conditions and may cause component damage.

⚠ WARNING Electrocutation hazard. Contact with hot or live circuits could result in death or serious injury. Remove all rings, watches and other jewelry.

- 1 Inspect the following areas for burnt, chafed, corroded and loose wires:
 - Turntable area
 - Ground controls
 - Turntable rotation manifold wiring
 - Power unit wiring
 - Outrigger manifold wiring (if equipped)
- 2 Inspect for a liberal coating of dielectric grease in the following locations:
 - Between the ground and platform controls
 - All harness connectors
 - Level sensor
- 3 Turn the key switch to ground control and pull out the red Emergency Stop button to the on position at both the ground and platform controls.
- 4 Raise the secondary boom until the platform is approximately 10 feet / 3 m off the ground.
- 5 Inspect the boom storage area for burnt, chafed and pinched cables.
- 6 Lower the boom to the stowed position and turn the machine off.
- 7 Inspect the following areas for burnt, chafed, corroded, pinched and loose wires:
 - Boom to platform cable harness
 - Primary, secondary and jib booms

CHECKLIST B PROCEDURES

REV C

B-3 Test the Emergency Stop

A properly functioning Emergency Stop is essential for safe machine operation. An improperly operating red Emergency Stop button will fail to shut off power and stop all machine functions, resulting in a hazardous situation.

NOTICE As a safety feature, selecting and operating the ground controls will override the platform controls, except the platform red Emergency Stop button.

- 1 Turn the key switch to ground control and pull out the red Emergency Stop button to the on position at both the ground and platform controls.
- 2 Push in the red Emergency Stop button at the ground controls to the off position.
- ⦿ Result: No machine functions should operate.
- 3 Turn the key switch to platform control and pull out the red Emergency Stop button to the on position at both the ground and platform controls.
- 4 Push down the red Emergency Stop button at the platform controls to the off position.
- ⦿ Result: No machine functions should operate.

NOTICE The red Emergency Stop button at the ground controls will stop all machine operation without regard to the position of the key switch.

B-4 Test the Key Switch

Proper key switch action and response is essential to safe machine operation. The machine can be operated from the ground or platform controls and the activation of one or the other is accomplished with the key switch. Failure of the key switch to activate the appropriate control panel could cause a hazardous operating situation.

NOTICE Perform this procedure from the ground using the platform controls. Do not stand in the platform.

- 1 Pull out the red Emergency Stop button to the on position at both the ground and platform controls.
- 2 Turn the key switch to **platform control**.
- 3 Check the platform up/down function from the **ground controls**.
- ⦿ Result: The machine functions should **not** operate.
- 4 Turn the key switch to **ground control**.
- 5 Check the machine functions from the **platform controls**.
- ⦿ Result: The machine functions should **not** operate.
- 6 Turn the key switch to the off position.
- ⦿ Result: No function should operate.

REV C

CHECKLIST B PROCEDURES

B-5 Test the Manual Lowering Operation

Testing the manual lowering operation for malfunctions is essential for safe machine operation. An unsafe working condition exists if the manual lowering function does not operate in the event of a main power loss.

- 1 Raise the primary boom approximately 1 foot / 0.3 m.
- 2 Raise the secondary boom approximately 1 foot / 0.3 m.
- 3 Raise the jib boom approximately 1 foot / 0.3 m.
- 4 Push in the red Emergency Stop button to the off position at both the ground and platform controls. Turn the key switch to the off position.
- 5 **From serial number T3498-001 to T3499-769:** Locate the proportional valve on the hydraulic power unit. Fully loosen the jam nut and turn the thumbscrew fully in a clockwise direction to open the proportional valve.

NOTICE The individual boom manual lowering valves will not function until the proportional valve is open.

From serial number T3400-001 to date:

Locate the proportional valve on the hydraulic power unit. Push and turn the brass knob in a clockwise direction to open the proportional valve.

NOTICE The individual boom manual lowering valves will not function until the proportional valve is open.

- 6 Locate the manual lowering valve at the base of the secondary boom lift cylinder. Push and hold the override knob until the secondary boom is fully lowered.

NOTICE The override knob is protected by a black rubber cover.

- 7 Locate the manual lowering valve at the base of the primary boom lift cylinder. Push and hold the override knob until the secondary boom is fully lowered.

NOTICE The override knob is protected by a black rubber cover.

- 8 Locate the manual lowering valve at the base of the jib boom lift cylinder. Push and hold the override knob until the secondary boom is fully lowered.

NOTICE The override knob is protected by a black rubber cover.

- 9 **From serial number T3498-001 to T3499-769:** Turn the thumbscrew at the proportional valve fully in a counterclockwise direction. Tighten the jamb nut against the proportional valve coil.

NOTICE The boom will not function until the proportional valve is closed.

From serial number T3400-001 to date: Push and turn the brass knob at the proportional valve in a counterclockwise direction to close the valve.

NOTICE The boom will not function until the proportional valve is closed.

CHECKLIST B PROCEDURES

REV C

B-6 Inspect the Tires and Wheels (including lug nut or lug bolt torque)



Maintaining the tires and wheels in good condition is essential to safe operation and good performance. Tire and/or wheel failure could result in a machine tip-over. Component damage may also result if problems are not discovered and repaired in a timely fashion.

- 1 Check the tire tread and sidewalls for cuts, cracks, punctures and unusual wear.
- 2 Check each wheel for damage, bends and cracked welds.
- 3 Check each lug nut or lug bolt for proper torque. Refer to Section 2, *Specifications*.
- 4 Check the air pressure of each tire. Refer to Section 2, *Specifications*.

B-7 Service the Tongue Jack



Maintaining the tongue jack in good condition is essential to safe operation and good machine performance. Failure to lubricate the internal gears and bearings of the jack and axle bolt could result in unsafe operating conditions and may cause component damage.

- 1 Using a needle nose applicator, pump a small amount of automotive grease through the lubrication opening on the side of the jack. Rotate the handle to evenly distribute the lubricant to the internal gears.

NOTICE The lubrication opening is located on the side of the jack, above the support plate.

- 2 Lightly grease the inner tube of the jack with automotive grease.
- 3 Lubricate the handle at both sides of the tube with a lightweight oil.
- 4 Lubricate the axle bolt and nut assembly with a lightweight oil.
- 5 Check each tire with an air pressure gauge and add air as needed. Refer to Section 2, *Specifications*.

WARNING An over-inflated tire can explode and could result in death or serious injury.

REV C

CHECKLIST B PROCEDURES

B-8 Inspect the Parking Brake



A properly functioning parking brake is essential to safe machine operation. The parking brake is manually activated. An improperly functioning parking brake will prevent the operator from properly securing the machine when not in use.

NOTICE Perform this procedure on a firm, level surface.

- 1 Visually inspect the parking brake cables and components for damage.
- 2 Visually inspect the parking brake cables to ensure both are properly secured and installed into the brake backing plate.
- 3 Set the parking brake.

NOTICE If the brake cables are too tight the parking brake assembly will be difficult to apply. If the brake cables are too loose, the brakes will not activate when the lever is set.

- 4 Attempt to manually push the machine.
 - ⦿ Result: The machine should not move.
 - ⦿ Result: The machine moves. Proceed to step 5.
- 5 Release the parking brake.

- 6 Loosen the set screw at the side of the parking brake handle.
- 7 Turn the handle in a clockwise direction just to the point where it is difficult to apply the parking brake, then rotate the top of the parking brake handle counterclockwise one full turn.
- 8 Tighten the set screw. Do not overtighten.
- 9 Repeat this procedure beginning with step 3.

CHECKLIST B PROCEDURES

REV C

B-9**Test the Horn**

A functioning horn is essential to safe machine operation. The horn is activated at the ground, platform or drive controls and sounds at the ground as a warning to ground personnel. An improperly functioning horn will prevent the operator from alerting ground personnel of hazards or unsafe conditions.

- 1 Turn the key switch to platform control and pull out the Emergency Stop button to the on position at both the ground and platform controls.
- 2 Push down the horn button at the platform controls.
- ⊙ Result: The horn should sound.
- 3 Push down the horn button at the ground controls.
- ⊙ Result: The horn should not sound.
- 4 Turn the key switch to ground control.
- 5 Push down the horn button at the ground controls.
- ⊙ Result: The horn should sound.
- 6 Push down the horn button at the platform controls.
- ⊙ Result: The horn should not sound.

B-10**Test the Flashing Beacon
(if equipped)**

The flashing beacon is used to alert operators and ground personnel of machine proximity and motion. The flashing beacon is located on the upper (primary) boom.

- 1 Turn the key switch to ground control and pull out the red Emergency Stop button to the on position at both the ground and platform controls. Pull out the red Emergency Stop button to the on position at the drive controls (if equipped).
- ⊙ Result: The beacons should flash.
- 2 Turn the key switch to platform controls.
- ⊙ Result: The beacons should flash.

REV C

CHECKLIST B PROCEDURES

B-11 Test the Platform Rotation (if equipped)

Testing the platform rotation for malfunctions is essential for safe machine operation. The platform rotator is operated by manually turning the hand crank in either a clockwise or counterclockwise direction.

- 1 Turn the hand crank at the platform in the clockwise direction.
- ⦿ Result: The platform should rotate to the right and operate smoothly without any hesitation or binding.
- 2 Turn the hand crank at the platform in the counterclockwise direction.
- ⦿ Result: The platform should rotate to the left and operate smoothly without any hesitation or binding.

B-12 Inspect the Hydraulic Tank Cap Venting System



NOTICE

Genie requires that this procedure be performed quarterly or every 250 hours, whichever comes first. Perform this procedure more often if dusty conditions exist.

A free-breathing hydraulic tank cap is essential for good machine performance and service life. A dirty or clogged cap may cause the machine to perform poorly. Extremely dirty conditions may require that the cap be inspected more often.

- 1 Remove the breather cap from the hydraulic tank.
- 2 Check for proper venting.
- ⦿ Result: Air passes through the breather cap.
- ✗ Result: If air does not pass through the cap, clean or replace the cap. Proceed to step 3.

NOTICE

When checking for positive tank cap venting, air should pass freely through the cap.

- 3 Using a mild solvent, carefully wash the cap venting system. Dry using low pressure compressed air. Repeat step 2.
- 4 Install the breather cap onto the hydraulic tank.

CHECKLIST B PROCEDURES

REV C

B-13 Perform Hitch Maintenance - ANSI Models



NOTICE Hitch specifications require that this procedure be performed initially after 1000 miles of use, and every 2000 miles of use thereafter.

Proper hitch maintenance, following the hitch manufacturer's maintenance schedule, is essential to good hitch performance and service life. Failure to perform the maintenance procedures can lead to poor hitch performance and component damage.

Required maintenance procedures and additional hitch information is available in the *Atwood Model MPD84132 Brake Actuators Owner/Operator Manual* (Atwood part number MPD85778).

Atwood Model MPD84132 Owner/Operator Manual	
Genie part number	97403

B-14 Perform Axle Maintenance - ANSI Models



NOTICE Axle specifications require that this procedure be performed quarterly or every 3000 miles, whichever comes first.

Proper axle maintenance, as specified in the axle manufacturer's maintenance schedule, is essential to good axle performance and service life. Failure to perform the maintenance procedures can lead to poor axle performance and component damage.

Required maintenance procedures and additional axle information is available in the *Dexter Axle Operation Maintenance Service Manual* (Dexter part number LIT-001-00).

Dexter Axle Operation Maintenance Service Manual	
Genie part number	84376

REV C

CHECKLIST B PROCEDURES

B-15 Perform Hydraulic Oil Analysis



Replacement or testing of the hydraulic oil is essential for good machine performance and service life. Dirty oil and suction strainers may cause the machine to perform poorly and continued use may cause component damage. Extremely dirty conditions may require oil changes to be performed more often.

NOTICE Before replacing the hydraulic oil, the oil may be tested by an oil distributor for specific levels of contamination to verify that changing the oil is necessary. **If the hydraulic oil is not replaced at the two year inspection, test the oil quarterly. Replace the oil when it fails the test.** See E-1, *Test or Replace the Hydraulic Oil.*

Checklist C Procedures

REV C

C-1 Replace the Hydraulic Tank Breather Cap - Models with Optional Hydraulic Oil



The hydraulic tank is a vented-type tank. The breather cap has an internal air filter that can become clogged or, over time, can deteriorate. If the breather cap is faulty or improperly installed, impurities can enter the hydraulic system which may cause component damage. Extremely dirty conditions may require that the cap be inspected more often.

- 1 Remove and discard the hydraulic tank breather cap.
- 2 Install a new cap onto the tank.

C-2 Perform Axle Maintenance - ANSI Models



NOTICE

Axle specifications require that this procedure be performed every 6 months or 6000 miles, whichever comes first.

Required maintenance procedures and additional axle information is available in the *Dexter Axle Operation Maintenance Service Manual* (Dexter part number LIT-001-00).

Dexter Axle Operation Maintenance Service Manual
Genie part number 84376

REV C

CHECKLIST C PROCEDURES

C-3

Perform Hitch Maintenance - CE Models



NOTICE Hitch specifications require that this procedure be performed semi-annually.

Proper hitch maintenance, following the hitch manufacturer's maintenance schedule, is essential to good hitch performance and service life. Failure to perform the maintenance procedures can lead to poor hitch performance and component damage.

Required maintenance procedures and additional axle information is available in the *Knott Axle Service Manual* (Knott part number P005).

Knott Axle Service Manual

Genie part number

84443

Checklist D Procedures

REV C

D-1 Check the Turntable Rotation Bearing Bolts



Maintaining proper torque on the turntable bearing bolts is essential to safe machine operation. Improper bolt torque or torque sequence could result in an unsafe operating condition and component damage.

- 1 Be sure that each turntable rotation bearing mounting bolt securing the turntable to the rotate bearing (above the turntable) is torqued in sequence to specification. See below.

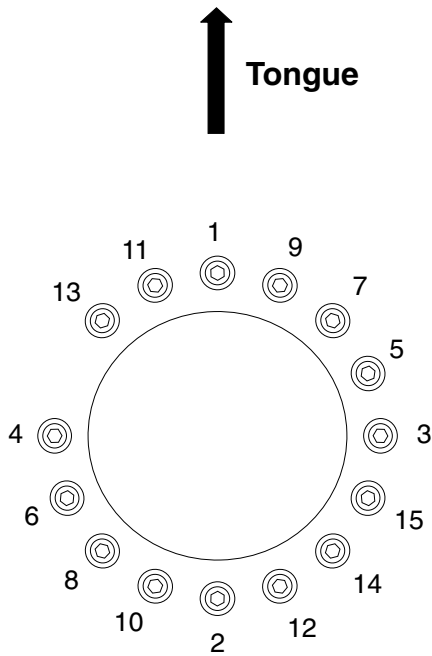

- 2 Working through the bearing bolt access, be sure that each turntable rotation bearing mounting bolt above the turntable is torqued in sequence to specification. See below.

NOTICE

The rotate bearing bolt access is located next to the turntable rotate motor.

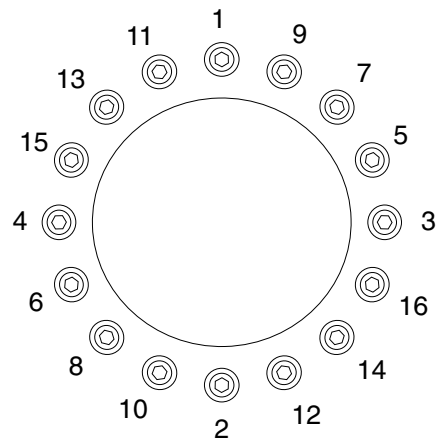

Bearing-to-chassis bolt torque sequence

Turntable rotation bearing torque specifications

Bearing-to-turntable, dry	175 ft-lbs 237 Nm
Bearing-to-chassis, dry	105 ft-lbs 142 Nm

REV C

CHECKLIST D PROCEDURES

D-2 Inspect for Turntable Bearing Wear



Periodic inspection of turntable bearing wear is essential to safe machine operation, good machine performance and service life. Continued use of a worn turntable bearing could create an unsafe operating condition, resulting in death or serious injury and component damage.

NOTICE Perform this procedure with the machine on a firm, level surface and the boom in the stowed position.

- Grease the turntable bearing. See A-11, *Grease the Turntable Rotation Bearing and Rotate Gear*.
- Torque the turntable bearing bolts to specification. See D-1, *Check the Turntable Rotation Bearing Bolts*.
- Start the machine from the ground controls and raise the primary and secondary booms to full height. Do not extend the primary boom.
- Place a dial indicator between the drive chassis and the turntable at a point that is directly under, or inline with, the boom and no more than 1 inch / 2.5 cm from the bearing.

NOTICE To obtain an accurate measurement, place the dial indicator no more than 1 inch / 2.5 cm from the turntable rotation bearing.

- At the dial indicator, adjust it to "zero" the indicator.

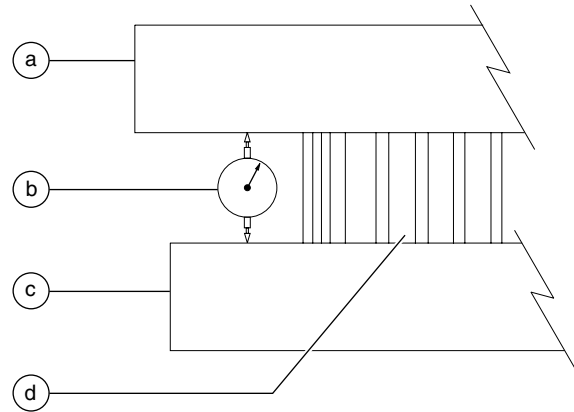

a turntable
b dial indicator
c drive chassis
d turntable rotation bearing

- Lower the secondary boom to the stowed position and lower the primary boom to a horizontal position. Fully extend the primary boom.
- Note the reading on the dial indicator.
 - ⊙ Result: The measurement is less than 0.025 inch / 0.635 mm. The bearing is good.
 - ✗ Result: The measurement is more than 0.0249 inch / 0.634 mm. The bearing is worn and needs to be replaced.
- Fully retract the primary boom. Raise the primary and secondary booms to full height. Visually inspect the dial indicator to be sure the needle returns to the "zero" position.
- Remove the dial indicator and rotate the turntable 90°.
- Repeat steps 4 through 9 until the rotation bearing has been checked in at least four equally spaced areas 90° apart.
- Lower the primary and secondary booms to the stowed position and turn the machine off.
- Remove the dial indicator from the machine.

CHECKLIST D PROCEDURES

REV C

D-3**Replace the Hydraulic Tank
Return Filter**

Replacement of the hydraulic tank return filter element is essential for good machine performance and service life. A dirty or clogged filter element may cause the machine to perform poorly and continued use may cause component damage. Extremely dirty conditions may require that the filter element be replaced more often.

CAUTION Burn hazard. Beware of hot oil. Contact with hot oil may cause severe burns.

NOTICE The hydraulic filter is mounted on the function manifold next to the hydraulic power unit.

- 1 Clean the area around the hydraulic oil filter. Remove the filter with an oil filter wrench.

WARNING Bodily injury hazard. Spraying hydraulic oil can penetrate and burn skin. Loosen hydraulic connections very slowly to allow the oil pressure to dissipate gradually. Do not allow oil to squirt or spray.

- 2 Use a permanent ink marker to write the date and number of hours from the hour meter (if equipped) on the new filter.

- 3 Apply a thin layer of fresh oil onto the gasket of the new oil filter.
- 4 Install the filter and tighten it securely by hand.
- 5 Clean up any oil that may have spilled during the replacement procedure. Properly discard the used filter.
- 6 Turn the key switch to ground controls and pull out the red Emergency Stop button to the on position at both the ground and platform controls.
- 7 Move and hold the function enable toggle switch in the up direction and activate the platform up function.
- 8 Inspect the filter and related components to be sure that there are no leaks.

REV C

CHECKLIST D PROCEDURES

D-4 Perform Axle Maintenance - ANSI Models



NOTICE Axle specifications require that this procedure be performed every 12 months or 12000 miles, whichever comes first.

Required maintenance procedures and additional axle information is available in the *Dexter Axle Operation Maintenance Service Manual* (Dexter part number LIT-001-00).

Dexter Axle Operation Maintenance Service Manual
Genie part number 84376

D-5 Perform Hitch Maintenance - ANSI Models



NOTICE Hitch specifications require that this procedure be performed annually.

Proper hitch maintenance, following the hitch manufacturer's maintenance schedule, is essential to good hitch performance and service life. Failure to perform the maintenance procedures can lead to poor hitch performance and component damage.

Required maintenance procedures and additional hitch information is available in the *Atwood Model MPD84132 Brake Actuators Owner/Operator Manual* (Atwood part number MPD85778).

Atwood Model MPD84132 Owner/Operator Manual
Genie part number 97403

Checklist E Procedure

REV C

E-1 Test or Replace the Hydraulic Oil



Replacement or testing of the hydraulic oil is essential for good machine performance and service life. Dirty oil and suction strainers may cause the machine to perform poorly and continued use may cause component damage. Extremely dirty conditions may require oil changes to be performed more often.

NOTICE Before replacing the hydraulic oil, the oil may be tested by an oil distributor for specific levels of contamination to verify that changing the oil is necessary. **If the hydraulic oil is not replaced at the two year inspection, test the oil quarterly. Replace the oil when it fails the test.**

NOTICE Perform this procedure with the boom in the stowed position.

- 1 Disconnect the battery pack from the machine.
- 2 Remove the drain plug from the hydraulic tank and completely drain the tank into a suitable container. Refer to Section 2, *Specifications*, for capacity information.
- 3 Disconnect the hydraulic oil return line from the manifold side of the hydraulic oil filter.
- 4 Remove the mounting fasteners securing the hydraulic tank to the turntable.
- 5 Remove the mounting fasteners securing the hydraulic tank to the power unit. Remove the tank from the machine.
- 6 Remove the pick-up filter from hydraulic pump suction tube.
- 7 Clean the filter and tank using a mild solvent.
- 8 Apply thread sealant to the threads of the drain plug. Install the drain plug into the tank and torque to specification.

Torque specifications

Hydraulic tank drain plug, dry	250 in-lbs 28 Nm
Hydraulic tank drain plug, lubricated	188 in-lbs 21 Nm

- 9 Install the filter onto the pickup tube. Install the hydraulic tank onto the power unit and torque to specification.

NOTICE Be careful not to damage the O-ring when installing the hydraulic tank onto the power unit.

Torque specifications

Hydraulic tank mounting fasteners, dry	40 in-lbs 4.5 Nm
Hydraulic tank mounting fasteners, lubricated	30 in-lbs 3.4 Nm

- 10 Install the hydraulic power unit onto the turntable. Securely install the fasteners.
 - 11 Fill the tank with hydraulic oil until the oil is visible in the sight gauge. Do not overfill. Refer to Section 2, *Specifications*.
 - 12 Activate the pump to fill the hydraulic system with oil and bleed the system of air.
- CAUTION** Component damage hazard. The pump can be damaged if operated without oil. Do not empty the hydraulic tank while in the process of filling the hydraulic system.
- 13 Repeat steps 11 through 12 until the hydraulic system and tank are both full.
 - 14 Retract the outriggers and return the boom to the stowed position.
 - 15 Clean up any oil that may have spilled. Properly discard the used oil and filter.

Repair Procedures



Observe and Obey:

- ☑ Repair procedures shall be completed by a person trained and qualified on the repair of this machine.
- ☑ Immediately tag and remove from service a damaged or malfunctioning machine.
- ☑ Repair any machine damage or malfunction before operating the machine.

Before Repairs Start:

- ☑ Read, understand and obey the safety rules and operating instructions in the *Genie TMZ-34/19 Operator's Manual*.
- ☑ Be sure that all necessary tools and parts are available and ready for use.
- ☑ Read each procedure completely and adhere to the instructions. Attempting shortcuts may produce hazardous conditions.
- ☑ Unless otherwise specified, perform each repair procedure with the machine in the following configuration:
 - Machine disconnected from tow vehicle
 - Machine parked on a firm, level surface with the boom stowed and both latches secured
 - Key switch in the off position with the key removed
 - The red Emergency Stop button in the off position at both ground and platform controls
 - Wheels chocked and parking brake applied
 - All external AC power supply disconnected from the machine

About This Section

Most of the procedures in this section should only be performed by a trained service professional in a suitably equipped workshop. Select the appropriate repair procedure after troubleshooting the problem. Perform disassembly procedures to the point where repairs can be completed. Then to re-assemble, perform the disassembly steps in reverse order.

Symbols Legend



Safety alert symbol—used to alert personnel to potential personal injury hazards. Obey all safety messages that follow this symbol to avoid possible injury or death.

▲ DANGER

Red—used to indicate the presence of an imminently hazardous situation which, if not avoided, will result in death or serious injury.

▲ WARNING

Orange—used to indicate the presence of a potentially hazardous situation which, if not avoided, could result in death or serious injury.

▲ CAUTION

Yellow with safety alert symbol—used to indicate the presence of a potentially hazardous situation which, if not avoided, may cause minor or moderate injury.

CAUTION

Yellow without safety alert symbol—used to indicate the presence of a potentially hazardous situation which, if not avoided, may result in property damage.

NOTICE

Green—used to indicate operation or maintenance information.

- ◎ Indicates that a specific result is expected after performing a series of steps.
- ☒ Indicates that an incorrect result has occurred after performing a series of steps.

Platform Controls

REV C

Activating one or more buttons on the platform controls first sends a signal to the platform controls circuit board, then to the ground controls printed circuit boards which ultimately activates a machine function. Keeping the platform controls clean and defect free is essential to safe machine operation.

The platform controls contain a printed circuit board, alarm, LEDs and push buttons or a membrane overlay decal. Models before serial number T3400-001 are equipped with push buttons to activate machine functions while models after T3499-769 rely on a membrane overlay decal to activate machine functions. All of the components are replaceable.

For further information or assistance, consult the Genie Industries Service Department.

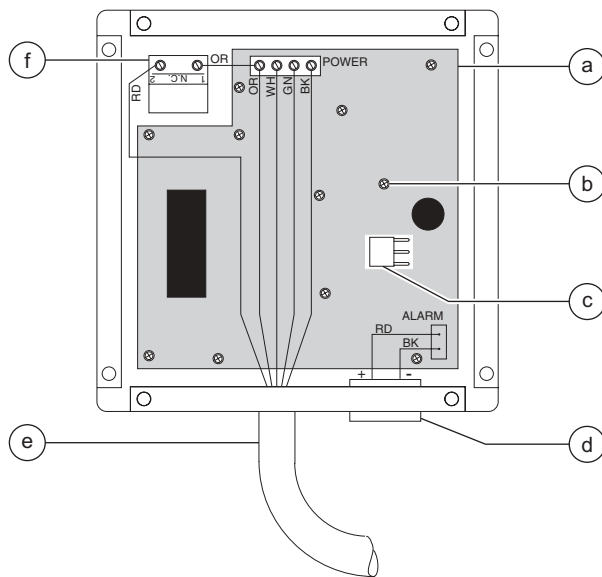

Models from serial number T3498-001 to T3499-769

- a platform controls circuit board U3
- b mounting fasteners
- c voltage regulator D7
- d horn H1
- e control cable
- f red Emergency Stop button P2

1-1 Circuit Board

How to Remove the Circuit Board

- 1 Tag and disconnect the platform controls wire harness from the harness connector at the platform pivot.
- 2 Remove the platform controls from the machine. Release the clamp on the back of the platform controls and slide the controls up and off of the platform. Place the control box on a work bench.

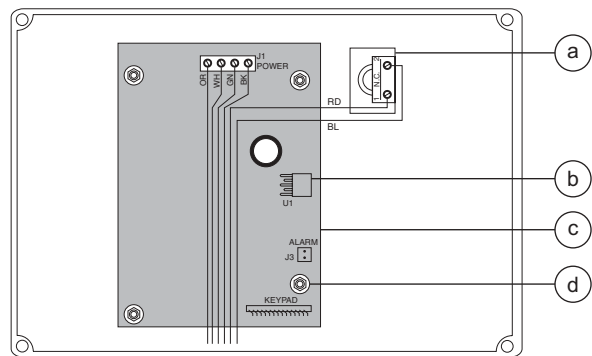

Models from serial number T3400-001 to date

- a red Emergency Stop button P2
- b voltage regulator D7
- c platform controls circuit board U3
- d mounting fasteners

REV C

PLATFORM CONTROLS

3 From serial number T3498-001 to T3499-769:

Remove the back cover retaining fasteners from the back of the platform controls and remove the back cover.

From serial number T3400-001 to date:

Disconnect the retaining fasteners at the front cover of the platform controls and open the platform control box.

- 4 Tag and disconnect the wire connectors from the circuit board.

CAUTION

Component damage hazard. Electrostatic discharge (ESD) can damage printed circuit board components. Maintain firm contact with a metal part of the machine that is grounded at all times when handling printed circuit boards OR use a grounded wrist strap.

- 5 Remove the circuit board mounting fasteners and remove the circuit board from the box.

1-2

Membrane Overlay

How to Replace the Overlay

NOTICE

Beginning with the 2000 model year (from serial number T3400-001 to date), the platform control box was equipped with a membrane overlay decal. The following procedure will not apply for TMZ-34 models manufactured in the 1998 and 1999 model years (from serial number T3498-001 to T3499-769).

- 1 Remove the platform controls from the machine. Open the clamp on the back of the platform controls and slide the controls up and off of the platform.
- 2 Tag and disconnect the platform control wire harness from the harness connector at the platform pivot and place the platform control box on a work bench.
- 3 Loosen the platform control box lid retaining fasteners and open the lid.

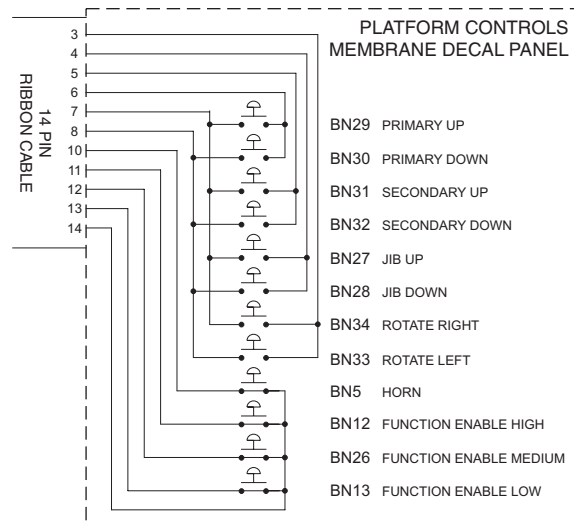

PLATFORM CONTROLS

REV C

- 4 Disconnect the large blue connector from the circuit board at the connection marked "KEYPAD" by sliding the connector parallel to the circuit board.

CAUTION Component damage hazard. The circuit board will become damaged if the wire harness and connector are disconnected without proper care. Do not pull upwards on the connector.

CAUTION Component damage hazard. The circuit board may become damaged if the weight from the control box lid pulls on the wire harness. Do not put any weight or strain on the wires.

CAUTION Component damage hazard. Electrostatic discharge (ESD) can damage printed circuit board components. Maintain firm contact with metal that is grounded at all times when handling printed circuit boards OR use a grounded wrist strap.

- 5 Install the lid onto the control box. Finger-tighten the retaining fasteners.
- 6 Starting at the upper corners of the touch pad, remove all layers of the key pad from the control box lid.

NOTICE The wire harness and large blue connector will interfere if removing the touch pad from the bottom.

- 7 Pull the large blue connector through the slot in the control box lid and discard the old touch pad. Remove any remaining sealant from the slot.
- 8 Using a mild solvent, clean the surface of the control box lid. Allow the surface to dry.

CAUTION Component damage hazard. The circuit board will become damaged if it comes in contact with solvent. Do not allow solvent to contact the circuit board.

- 9 Remove all the brown backing material from the new touch pad.

- 10 Insert the large blue connector from the new touch pad through the slot. Carefully align the low battery LED on the control box lid with the window in the new touch pad and lightly lay the touch pad onto the control box lid.

NOTICE Repositioning the touch pad is possible if the touch pad is lightly adhered to the lid. Do not apply any pressure to the touch pad.

- 11 When satisfied with the position of the touch pad, firmly press down the entire surface of the touch pad with your fingers.
- 12 Loosen the platform control box lid retaining fasteners and open the lid.
- 13 Using RTV-type sealant, completely seal the opening in the slot of the control box lid around the wire harness.
- 14 Apply dielectric grease to the pins on the circuit board at the connection marked "KEYPAD."
- 15 Install the large blue connector onto the circuit board pins at the connection marked "KEYPAD," by sliding the connector parallel to the circuit board, until the connector is pushed onto the circuit board pins no less than 0.2 inch / 5 mm.

NOTICE Be sure all pins are in the connector.

- 16 Install the lid onto the control box and tighten the retaining fasteners. Do not overtighten.
- 17 Install the platform controls onto the machine.
- 18 Connect the platform control wire harness to the harness connector at the platform pivot.

Platform Components

REV C

2-1 Platform

How to Remove the Platform

Models with Platform Rotate (option):

- 1 Support the platform with an appropriate lifting device.
- 2 Remove the fasteners securing the platform to the platform mount on the platform rotator assembly.

▲WARNING Crushing hazard. The platform may become unbalanced and fall if not properly supported by a lifting device when the fasteners are removed.

- 3 Lift and remove the platform from the mount.

Models without Platform Rotate:

- 1 Remove the platform controls from the platform control box mount. Release the clamp on the back of the platform control box and slide the controls up and off of the mount.
- 2 Support the platform with an appropriate lifting device.
- 3 Remove the toggle pin securing the platform to the platform mount.

▲WARNING Crushing hazard. The platform may become unbalanced and fall if not properly supported when the toggle pin is removed.

- 4 Lift and remove the platform from the mount.

2-2 Platform Rotator (if equipped)

The platform rotator is a manually-operated gear assembly used to rotate the platform 160 degrees.

How to Remove the Platform Rotator

- 1 Remove the platform. See 2-1, *How to Remove the Platform*.
- 2 Remove the platform controls from the platform control box mount. Release the clamp on the back of the platform control box and slide the controls up and off of the mount. Lay the platform controls off to the side.

▲CAUTION Component damage hazard. Cables can be damaged if they are kinked or pinched.

- 2 Support the platform rotator with an appropriate lifting device.
- 3 Remove the toggle pin securing the platform to the platform mount.

▲WARNING Crushing hazard. The platform rotator may become unbalanced and fall if not properly supported when the toggle pin is removed.

- 4 Lift the platform rotator off the platform mount.

PLATFORM COMPONENTS

REV C

How to Adjust the Platform Rotator

The platform rotator is designed to allow the platform to slip in the event of striking an object to help prevent damage to the platform. If the platform rotator is too tight or seized, damage to the platform may occur. If the platform rotator is too loose, the platform may rotate side to side unexpectedly, resulting in a unsafe operating condition.

- 1 Raise the primary boom approximately 3 feet / 1 m.
- 2 Press the function enable button and the platform level button in the down direction until the platform is horizontal. Do not allow the platform to contact the ground.
- 3 Remove the platform controls from the platform control box mount. Release the clamp on the back of the platform control box and slide the controls up and off of the mount. Lay the platform controls off to the side.

CAUTION Component damage hazard. Cables can be damaged if they are kinked or pinched.

- 4 Remove the fasteners securing the platform box mount and gearbox cover to the platform rotate gearbox. Remove the mount and cover from the gearbox.
- 5 Locate the gear assembly retaining nut on the end of the platform pivot shaft. Loosen the nut just enough to allow the handle to rotate.
- 6 Tighten the locknut. Torque to specification.

Torque specification

Gear assembly retaining nut, dry	180 ft-lbs ±5 ft-lbs 244 Nm ±7 Nm
----------------------------------	--------------------------------------

- 7 Thoroughly grease the entire mechanical platform rotator assembly.
- 8 Operate the platform rotator and check for smooth operation.

How to Service the Platform Rotator

- 1 Remove the platform. See 2-1, *How to Remove the Platform*.
- 2 Remove the platform controls from the platform control box mount. Release the clamp on the back of the platform control box and slide the controls up and off of the mount. Lay the platform controls off to the side.

CAUTION Component damage hazard. Cables can be damaged if they are kinked or pinched.

- 3 Remove the fasteners securing the platform control box mount and gearbox cover to the top of the gearbox case. Remove the mount and cover.
- 4 Remove the four bolts securing the rotate handle shaft cover to the gearbox.
- 5 Remove the rotate handle shaft and pinion from the gearbox case.
- 6 Remove the gear assembly retaining nut from the top of the shaft.
- 7 Disassemble the gear assembly.

NOTICE For ease of reinstallation, note the removal order of each gear component.

- 8 Visually inspect the inside of the platform rotator for the following items:
 - Excessive wear
 - Broken or damaged parts
 - Rust or corrosion
 - Binding

NOTICE If any parts are lightly rusted or corroded, remove them and clean rust or corrosion off with a wire brush. If parts are worn, heavily rusted or corroded, replace them.

REV C

PLATFORM COMPONENTS

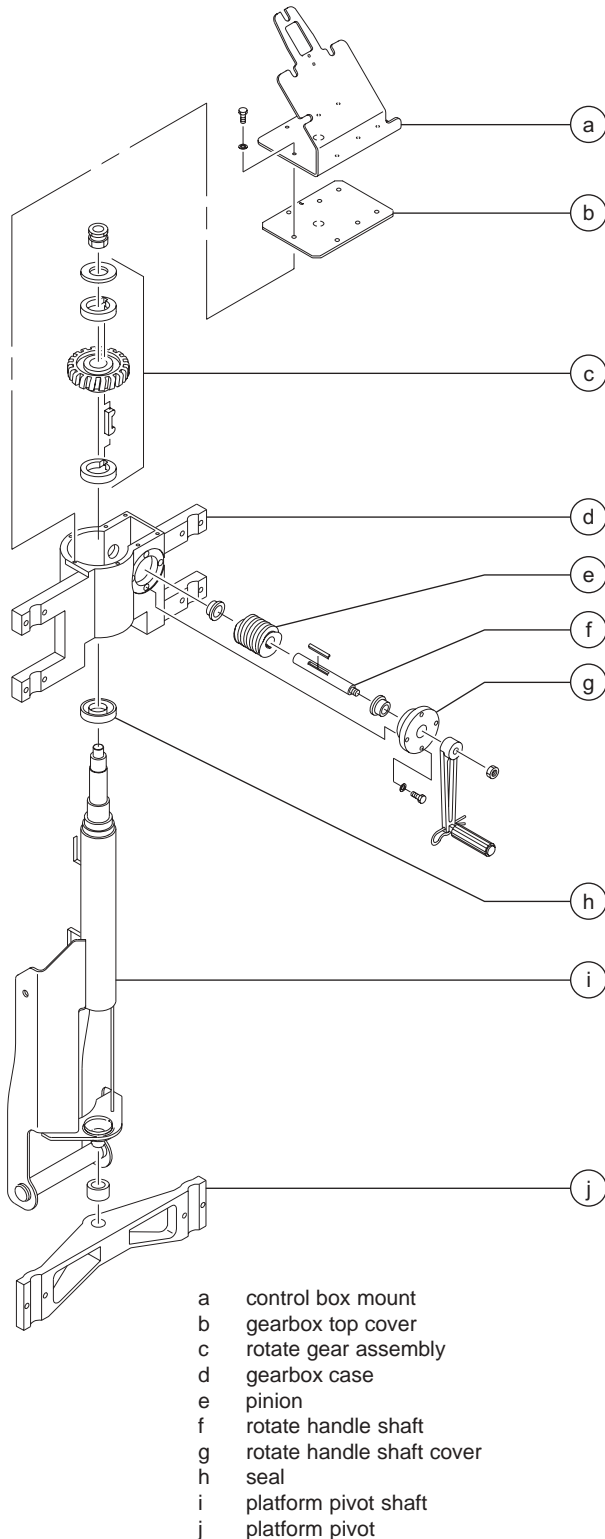

- 9 Thoroughly degrease and dry the gearbox case, covers, all gear components and the platform pivot shaft.
- 10 Install the gearbox case onto the platform pivot shaft.
- 11 Install gear assembly onto the platform pivot shaft in the reverse order of disassembly in step 7.
- 12 Install the gear assembly retaining nut onto the top of the shaft. Torque to specification.

Torque specification

Gear assembly retaining nut, dry	180 ft-lbs ±5 ft-lbs 244 Nm ±7 Nm
----------------------------------	--------------------------------------

- 13 Thoroughly and heavily lubricate each tooth of the gear using multipurpose grease. Rotate the gearbox case as required.

NOTICE When lubricating the gear, do not apply any grease to the remainder of the gear assembly components. Grease on the balance of the gear components may result in slippage and poor rotator performance.

- 14 Install the rotate handle shaft, pinion and associated components into the gearbox.
- 15 Thoroughly and heavily lubricate each tooth of the pinion using multipurpose grease.
- 16 Install the rotate handle shaft cover. Install and securely tighten the fasteners. Do not over tighten.
- 17 Install the platform control box mount and gearbox cover onto the top of the gearbox. Install and securely tighten the fasteners. Do not over tighten.

Jib Boom Components

REV C

3-1 Jib Boom

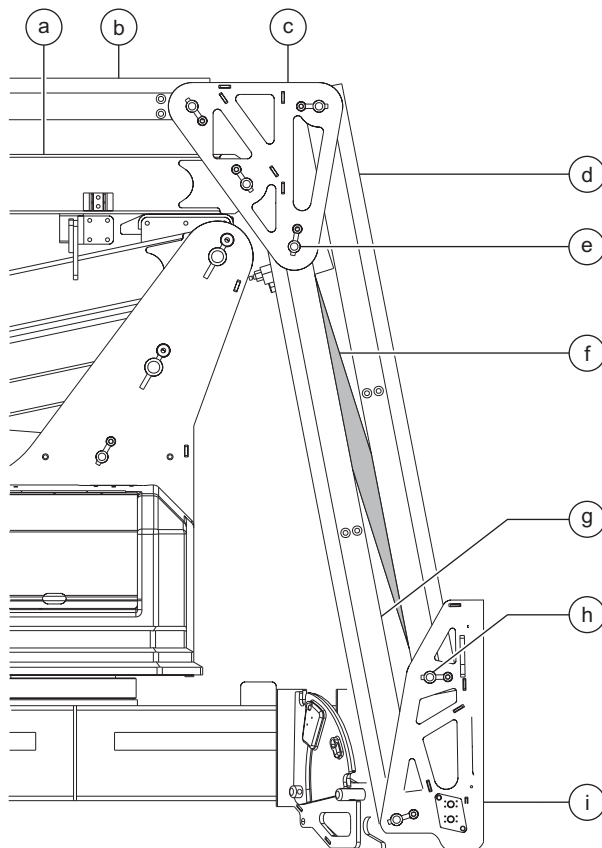

- a primary boom
- b primary linkage
- c jib boom mount
- d upper jib boom
- e jib boom cylinder barrel-end pivot pin
- f jib boom lift cylinder
- g lower jib boom
- h jib boom cylinder rod-end pivot pin
- i platform mount

How to Remove the Jib Boom

NOTICE Perform this procedure with the boom in the stowed position.

NOTICE When removing a hose assembly or fitting, the O-ring on the fitting and/or hose end must be replaced and then torqued to specification during installation. Refer to Section 2, *Hydraulic Hose and Fitting Torque Specifications*.

- 1 Remove the platform. See 2-1, *How to Remove the Platform*.
- 2 Disconnect the platform controls from the side of the platform mount.
- 3 Disconnect the platform control cable plug from the ground control box. Install the platform controls into the outlet.
- 4 Raise the jib boom 4 to 5 feet / 1.2 to 1.5 m.
- 5 Lower the jib boom until the platform mount rests on sawhorses or a work table of sufficient capacity.
- 5 Mark the location of each cable retaining plate in the upper jib boom.
- 6 Tag and remove the cable retaining plates from the upper jib boom.
- 7 Attach a lifting strap from an overhead crane to the rod end of the jib boom lift cylinder.
- 8 Remove the pin retaining fastener from the jib boom lift cylinder rod-end pivot pin.

REV C

JIB BOOM COMPONENTS

- 9 Using a soft metal drift, remove the jib boom lift cylinder rod-end pivot pin.

▲WARNING Crushing hazard. The jib boom lift cylinder could fall if not properly supported when the rod-end pivot pin is removed from the machine.

- 10 Attach a lifting strap from an overhead crane to the upper jib boom.
- 11 Remove the pin retaining fastener from the upper jib boom pivot pin at the jib boom mount.
- 12 Using a soft metal drift, remove the upper jib pivot pin from the jib boom mount. Remove the upper jib boom.

▲WARNING Crushing hazard. The upper jib boom could become unbalanced and fall if not properly supported when the pivot pin is removed.

- 13 Support and secure the platform mounting weldment.
- 14 Remove the pin retaining fastener from the lower jib boom pivot pin at the platform mount.
- 15 Using a soft metal drift, remove the lower jib boom pivot pin at the platform mount. Remove the platform mount from the machine.

▲WARNING Crushing hazard. The platform mount could become unbalanced and fall if not properly supported when the pivot pin is removed.

- 16 Tag, disconnect and plug the hydraulic hoses at the jib boom lift cylinder. Cap the fittings on the cylinder.

▲WARNING Bodily injury hazard. Spraying hydraulic oil can penetrate and burn skin. Loosen hydraulic connections very slowly to allow the oil pressure to dissipate gradually. Do not allow oil to squirt or spray.

- 17 Tag and disconnect the wires from the jib boom lift cylinder solenoid valve.
- 18 Support the jib boom lift cylinder with an overhead crane or similar lifting device.
- 19 Support the lower jib boom with a overhead crane or similar lifting device.
- 20 Remove the pin retaining fastener from the jib boom lift cylinder barrel-end pivot pin.
- 21 Using a soft metal drift, remove the jib boom lift cylinder barrel-end pivot pin. Remove the jib boom lift cylinder from the machine.

▲WARNING Crushing hazard. The jib boom lift cylinder could become unbalanced and fall if not properly supported when the barrel-end pivot pin is removed.

▲WARNING Crushing hazard. The lower jib boom could become unbalanced and fall if not properly supported when the pivot pin is removed.

CAUTION Component damage hazard. Be careful not to damage the solenoid valve on the cylinder while removing the cylinder.

JIB BOOM COMPONENTS

REV C

3-2 Jib Boom Cylinder

The jib boom lift cylinder raises and lowers the jib boom. The jib boom lift cylinder is equipped with a bi-directional solenoid valve to prevent movement in the event of a hydraulic line failure.

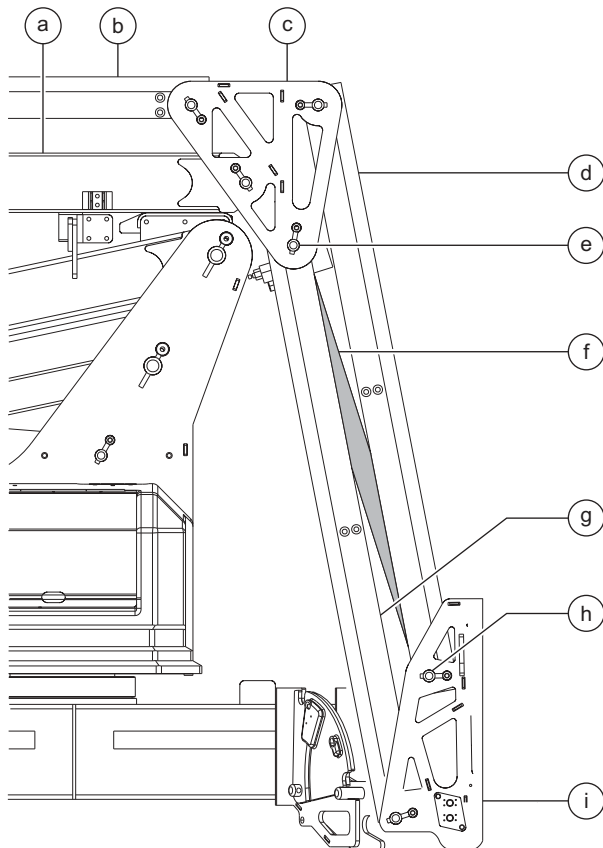

- a primary boom
- b primary linkage
- c jib boom mount
- d upper jib boom
- e jib boom cylinder barrel-end pivot pin
- f jib boom lift cylinder
- g lower jib boom
- h jib boom cylinder rod-end pivot pin
- i platform mount

How to Remove the Jib Boom Cylinder

NOTICE When removing a hose assembly or fitting, the O-ring on the fitting and/or hose end must be replaced and then torqued to specification during installation. Refer to Section 2, Hydraulic Hose and Fitting Torque Specifications.

- 1 Raise the jib boom approximately 3 feet / 1 m.
- 2 Lower the jib boom until the platform mount rests on sawhorses or a work table of sufficient capacity.
- 3 Disconnect the battery pack from the machine.

WARNING Electrocutation hazard. Contact with electrically charged circuits could result in death or serious injury. Remove all rings, watches and other jewelry.

- 4 Tag, disconnect and plug the hydraulic hoses at the jib boom cylinder. Cap the fittings on the cylinder.

WARNING Bodily injury hazard. Spraying hydraulic oil can penetrate and burn skin. Loosen hydraulic connections very slowly to allow the oil pressure to dissipate gradually. Do not allow oil to squirt or spray.

- 5 Tag and disconnect the wires from the jib boom cylinder solenoid valve.

REV C

JIB BOOM COMPONENTS

- 6 Attach a lifting strap of suitable capacity from an overhead crane to the jib boom lift cylinder. Support the cylinder. Do not apply any lifting pressure.
- 7 Remove the pin retaining fastener from the jib boom cylinder rod-end pivot pin.
- 8 Using a soft metal drift, remove the jib boom cylinder rod-end pivot pin.

▲WARNING Crushing hazard. The jib boom cylinder could fall if not properly supported when the rod-end pivot pin is removed from the machine.

- 9 Attach a lifting strap of suitable capacity from an overhead crane to the lower jib boom. Support the boom. Do not apply any lifting pressure.
- 10 Remove the pin retaining fastener from the jib boom lift cylinder barrel-end pivot pin.
- 11 Using a soft metal drift, remove the jib boom cylinder barrel-end pivot pin. Remove the jib boom cylinder from the machine.

▲WARNING Crushing hazard. The jib boom cylinder could become unbalanced and fall if not properly supported when the barrel-end pivot pin is removed from the machine.

▲WARNING Crushing hazard. The lower jib boom could become unbalanced and fall if not properly supported when the pivot pin is removed from the machine.

▲CAUTION Component damage hazard. The solenoid valve can be damaged. Use caution when removing the cylinder from the machine.

Boom Components

REV B

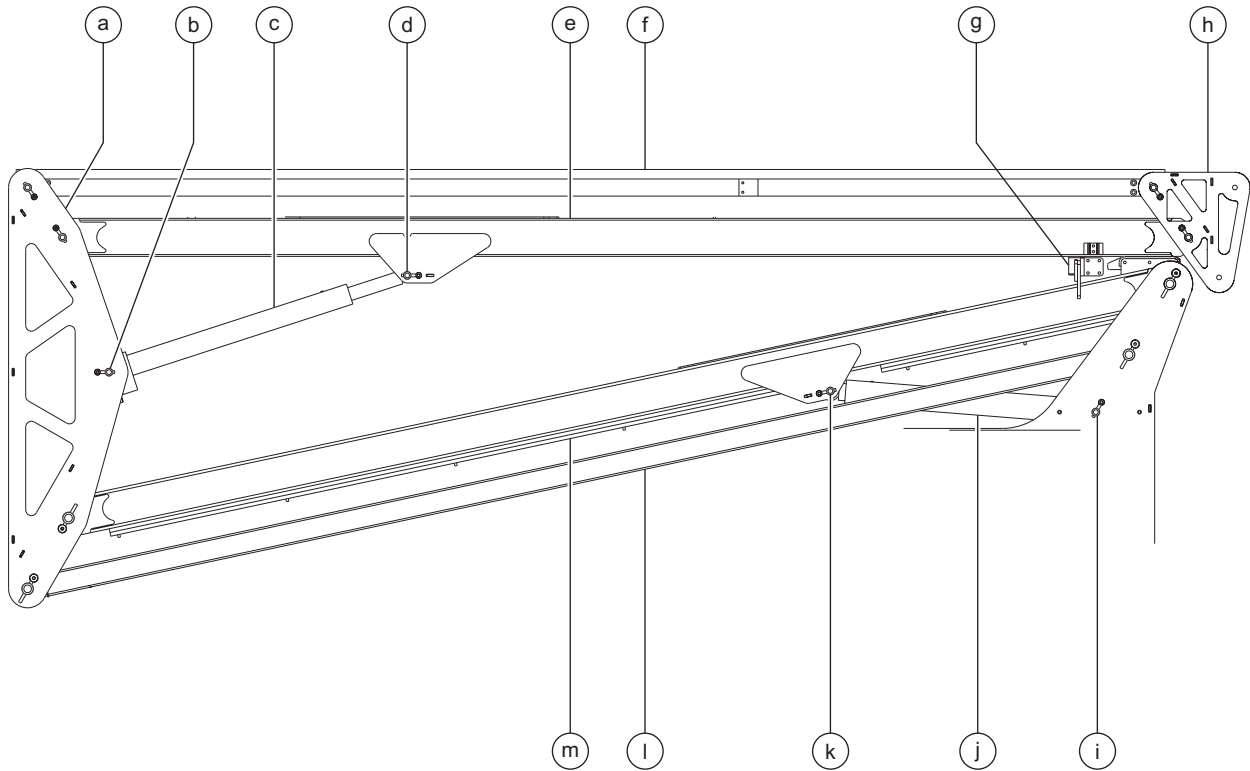

- | | | | |
|---|---|---|---|
| a | boom pivot | h | jib boom mount |
| b | primary boom lift cylinder barrel-end pivot pin | i | secondary boom lift cylinder barrel-end pivot pin |
| c | primary boom lift cylinder | j | secondary boom lift cylinder |
| d | primary boom lift cylinder rod-end pivot pin | k | secondary boom lift cylinder rod-end pivot pin |
| e | primary boom | l | secondary boom linkage |
| f | primary boom linkage | m | secondary boom |
| g | hold-down clamp | | |

REV B

BOOM COMPONENTS

4-1 Boom

How to Disassemble the Boom

WARNING This procedure in this section requires specific repair skills, lifting equipment and a suitable workshop. Attempting this procedure without these skills and tools could result in death or serious injury and significant component damage. Dealer service is required.

NOTICE Perform this procedure on a firm, level surface.

NOTICE Perform this procedure with the boom in the stowed position.

Follow the disassembly steps to the point required to complete the repair. Then re-assemble the secondary boom by following the disassembly steps in reverse order.

NOTICE When removing a hose assembly or fitting, the O-ring on the fitting and/or hose end must be replaced and then torqued to specification during installation. Refer to Section 2, *Hydraulic Hose and Fitting Torque Specifications*.

- 1 Remove the platform. See 2-1, *How to Remove the Platform*.
- 2 Remove the jib boom and jib boom lift cylinder. See 3-1, *How to Remove the Jib Boom*.

- 3 Tag and disconnect the wiring from the power receptacle on the platform mounting weldment.

WARNING Electrocutation hazard. Contact with electrically charged circuits could result in death or serious injury. Remove all rings, watches and other jewelry.

- 4 Remove the quick disconnect plug assembly retaining fasteners from the platform mount.

Models from serial number T3400-001 to date:

- 5 Remove the jib boom limit switch (LS11) from the platform mount.
- 6 Tag and disconnect the wiring from the jib boom limit switch.

All models:

- 7 Secure the primary boom with the hold-down latch.
- 8 Remove the cable retaining plates from the primary linkage.
- 9 Place blocks between the primary boom and primary linkage.
- 10 Attach a lifting strap from an overhead crane to the jib boom mount.
- 11 Remove the pin retaining fasteners from the primary linkage pivot pin to the jib boom pivot.
- 12 Using a soft metal drift, remove the primary linkage pivot pin at the jib boom mounting weldment.

BOOM COMPONENTS

REV B

13 Remove the pin retaining fasteners from the primary boom pivot pin at the jib boom mount.

14 Using a soft metal drift, remove the primary boom pivot pin at the jib boom mount.

▲WARNING Crushing hazard. The jib boom mount could become unbalanced and fall if not properly supported when the pivot pin is removed.

15 Remove the jib boom mount from the machine. Carefully pull the hoses and cables through the jib mount while removing it.

▲WARNING Crushing hazard. The jib boom mount could become unbalanced and fall if not properly supported when removed from the machine.

CAUTION Component damage hazard. Cables and hoses can be damaged if they are kinked or pinched.

16 Attach a lifting strap from an overhead crane to the primary boom linkage.

17 Remove the pin retaining fasteners from the primary boom linkage pivot pin at the boom pivot.

18 Using a soft metal drift, remove the primary boom linkage pivot pin at the boom pivot.

▲WARNING Crushing hazard. The primary boom linkage could become unbalanced and fall if not properly supported when the pivot pin is removed.

19 Remove the primary boom linkage from the machine.

▲WARNING Crushing hazard. The primary boom linkage could become unbalanced and fall if not properly supported when removed from the machine.

20 Carefully lay the hoses and cables over the boom pivot.

CAUTION Component damage hazard. Cables and hoses can be damaged if they are kinked or pinched.

21 Support and secure the primary boom lift cylinder to an appropriate lifting device.

22 Tag, disconnect and plug the hydraulic hoses at the primary boom lift cylinder. Cap the fitting on the cylinder.

▲WARNING Bodily injury hazard. Spraying hydraulic oil can penetrate and burn skin. Loosen hydraulic connections very slowly to allow the oil pressure to dissipate gradually. Do not allow oil to squirt or spray.

23 Tag and disconnect the wires from the primary boom lift cylinder.

24 Remove the pin retaining fasteners from the primary boom lift cylinder rod-end pivot pin.

REV B

BOOM COMPONENTS

25 Using a soft metal drift, remove the primary boom lift cylinder rod-end pivot pin.

▲WARNING Crushing hazard. The primary boom lift cylinder could fall if not properly supported when the pivot pin is removed.

26 Lower the cylinder onto the secondary boom.

27 Attach a lifting strap from an overhead crane to the primary boom.

28 Disconnect the primary boom hold-down latch.

29 Remove the pin retaining fasteners from the primary boom pivot pin at the boom pivot.

30 Using a soft metal drift, remove the primary boom pivot pin at the boom pivot.

▲WARNING Crushing hazard. The primary boom could become unbalanced and fall if not properly supported when the pivot pin is removed.

31 Remove the primary boom from the machine.

▲WARNING Crushing hazard. The primary boom could become unbalanced and fall if not properly supported when removed from the machine.

32 Attach a lifting strap from an overhead crane to the lug on the rod end of the primary boom lift cylinder. Raise the cylinder to a vertical position.

33 Remove the pin retaining fasteners from the primary boom lift cylinder barrel-end pivot pin.

34 Using a soft metal drift, remove the primary boom lift cylinder barrel-end pivot pin.

▲WARNING Crushing hazard. The primary boom lift cylinder could fall if not properly supported when the pivot pin is removed.

35 Remove the primary boom lift cylinder from the machine.

▲WARNING Crushing hazard. The lift cylinder could become unbalanced and fall if not properly supported when removed from the machine.

CAUTION Component damage hazard. The solenoid valve can be damaged. Use caution when removing the cylinder from the machine.

36 Tag and disconnect the limit switch wiring harness connector at the boom pivot.

37 Working at the male half of the connector, remove the cover from the end that inserts into the female half of the connector.

38 Carefully depress the pin locks and remove the wires from the connector.

NOTICE Note the location of each wire before removing from the harness connector.

39 Remove the hose/cable retaining clamps from the inside of the boom pivot.

40 Remove the front cable guard from the secondary boom.

BOOM COMPONENTS

REV B

- 41 Place blocks between the secondary boom and secondary linkage.

CAUTION Component damage hazard. Be careful not to damage the cables or hoses.

- 42 Attach a lifting strap from an overhead crane to the boom pivot.

- 43 Remove the pin retaining fasteners from the secondary boom pivot pin at the boom pivot.

- 44 Using a soft metal drift, remove the secondary boom pivot pin at the boom pivot.

AWARNING Crushing hazard. The boom pivot could fall if not properly supported when the pivot pin is removed.

- 45 Remove the pin retaining fastener from the primary linkage pivot pin at the boom pivot.

- 46 Using a soft metal drift, remove the primary linkage pivot pin at the boom pivot.

AWARNING Crushing hazard. The boom pivot will fall if not properly supported when the pivot pin is removed.

- 47 Slowly remove the boom pivot from the machine while pulling the cables and hoses through it.

AWARNING Crushing hazard. The boom pivot will fall if not properly supported when removed from the machine.

CAUTION Component damage hazard. Cables and hoses can be damaged if they are kinked or pinched.

- 48 Remove the rear cable guard from the secondary boom.

- 49 Place blocks across the turntable pivot plates, under the secondary boom lift cylinder.

- 50 Remove the pin retaining bolt from the secondary boom lift cylinder rod-end pivot pin.

- 51 Using a soft metal drift, remove the secondary boom lift cylinder rod-end pivot pin. Rest the cylinder on the boom linkage.

- 52 Attach a lifting strap from an overhead crane to the secondary boom.

- 53 Remove the pin retaining fasteners from the secondary boom pivot pin at the turntable pivot.

- 54 Using a soft metal drift, remove the secondary boom pivot pin at the turntable pivot.

- 55 Remove the secondary boom from the machine.

AWARNING Crushing hazard. The boom pivot will fall if not properly supported when removed from the machine.

- 56 Carefully lay the hoses and cables over the turntable pivot.

CAUTION Component damage hazard. Cables and hoses can be damaged if they are kinked or pinched.

- 57 Rotate the rod end lug of the secondary boom lift cylinder until it can clear the secondary linkage during removal. Lower the cylinder through the secondary boom linkage and rest it on the block.

REV B

BOOM COMPONENTS

58 Attach a lifting strap from an overhead crane to the secondary linkage.

59 Remove the pin retaining fasteners from the secondary linkage pivot pin at the turntable pivot.

60 Using a soft metal drift, remove the secondary linkage pivot pin at the turntable pivot.

61 Remove the secondary linkage from the machine.

▲WARNING Crushing hazard. The secondary linkage will fall if not properly supported when removed from the machine.

62 Support the secondary boom lift cylinder with an overhead crane or similar lifting device.

63 Tag, disconnect and plug the secondary boom lift cylinder hydraulic hoses at the secondary boom lift cylinder. Cap the fittings on the cylinder.

▲WARNING Bodily injury hazard. Spraying hydraulic oil can penetrate and burn skin. Loosen hydraulic connections very slowly to allow the oil pressure to dissipate gradually. Do not allow oil to squirt or spray.

64 Tag and disconnect the wires from the secondary boom lift cylinder.

65 Remove the pin retaining fasteners from the secondary boom lift cylinder barrel-end pivot pin at the turntable pivot.

66 Using a soft metal drift, remove the secondary boom lift cylinder barrel-end pivot pin.

▲WARNING Crushing hazard. If the overhead crane or lifting device is not properly attached, the primary boom lift cylinder may become unbalanced and fall when it is removed from the machine.

67 Remove the secondary boom lift cylinder from the machine.

▲WARNING Crushing hazard. The lift cylinder could become unbalanced and fall if not properly supported when removed from the machine.

CAUTION Component damage hazard. The solenoid valve can be damaged. Use caution when removing the cylinder from the machine.

BOOM COMPONENTS

REV B

4-2 Lift Cylinders

The primary boom lift cylinder raises and lowers the primary boom. The primary boom lift cylinder is equipped with a bi-directional solenoid valve to prevent movement in the event of a hydraulic line failure.

How to Remove the Primary Boom Lift Cylinder

NOTICE When removing a hose assembly or fitting, the O-ring on the fitting and/or hose end must be replaced and then torqued to specification during installation. Refer to Section 2, *Hydraulic Hose and Fitting Torque Specifications*.

NOTICE Perform this procedure on a firm, level surface.

- 1 Tag, disconnect and plug the hydraulic hoses on the primary boom lift cylinder. Cap the fittings on the cylinder.

WARNING Bodily injury hazard. Spraying hydraulic oil can penetrate and burn skin. Loosen hydraulic connections very slowly to allow the oil pressure to dissipate gradually. Do not allow oil to squirt or spray.

- 2 Tag and disconnect the wiring from the solenoid valve on the cylinder.
- 3 Support the primary boom lift cylinder with an overhead crane or similar lifting device.
- 4 Remove the pin retaining fastener from the primary boom lift cylinder barrel-end pivot pin.

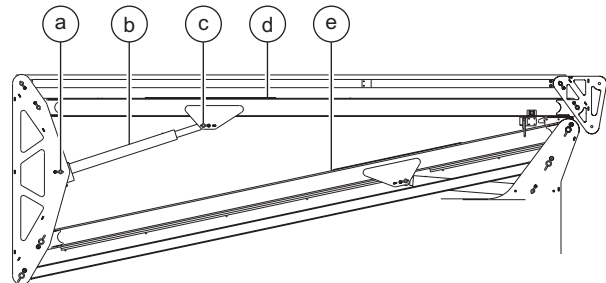

- a primary boom lift cylinder barrel-end pivot pin
- b primary boom lift cylinder
- c primary boom lift cylinder rod-end pivot pin
- d primary boom
- e secondary boom

- 5 Using a soft metal drift, remove the primary boom lift cylinder barrel-end pivot pin.

WARNING Crushing hazard. The lift cylinder will fall if not properly supported.

- 6 Lower the cylinder onto the secondary boom.

CAUTION Component damage hazard. The solenoid valve on the lift cylinder can be damaged if allowed to come in contact with the boom.

- 7 Remove the pin retaining fastener from the primary boom lift cylinder rod-end pivot pin.
- 8 Using a soft metal drift, remove the primary boom lift cylinder rod-end pivot pin.

WARNING Crushing hazard. The lift cylinder will fall if not properly supported.

- 9 Carefully remove the cylinder from the machine.

WARNING Crushing hazard. The lift cylinder could become unbalanced and fall if not properly supported when removed from the machine.

CAUTION Component damage hazard. The solenoid valve can be damaged. Use caution when removing the cylinder from the machine.

REV B

BOOM COMPONENTS

How to Remove the Secondary Boom Lift Cylinder

NOTICE When removing a hose assembly or fitting, the O-ring on the fitting and/or hose end must be replaced and then torqued to specification during installation. Refer to Section 2, *Hydraulic Hose and Fitting Torque Specifications*.

NOTICE Perform this procedure on a firm, level surface.

- 1 Tag, disconnect and plug the hydraulic hoses on the secondary boom lift cylinder. Cap the fittings on the cylinder.

AWARNING Bodily injury hazard. Spraying hydraulic oil can penetrate and burn skin. Loosen hydraulic connections very slowly to allow the oil pressure to dissipate gradually. Do not allow oil to squirt or spray.

- 2 Tag and disconnect the wiring from the solenoid valve on the cylinder.
- 3 Support the rod end of the cylinder with an appropriate lifting device.
- 4 Remove the pin retaining fastener from the secondary boom lift cylinder rod-end pivot pin.
- 5 Using a soft metal drift, remove the secondary boom lift cylinder rod-end pivot pin.

AWARNING Crushing hazard. The lift cylinder will fall if not properly supported.

- 6 Lower the cylinder onto the secondary linkage.
- 7 Attach an overhead crane to the boom pivot.
- 8 Carefully raise the boom pivot with the overhead crane until the secondary boom is in a horizontal position.

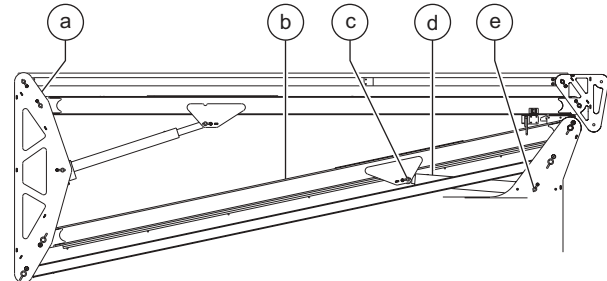

- a boom pivot
- b secondary boom
- c secondary boom lift cylinder rod-end pivot pin
- d secondary boom lift cylinder
- e secondary boom lift cylinder barrel-end pivot pin

- 9 Support the secondary boom lift cylinder with an appropriate lifting device.

- 10 Rotate the rod end lug of the secondary boom lift cylinder until it can clear the secondary linkage during removal.

- 11 Remove the pin retaining fastener from the secondary boom lift cylinder barrel-end pivot pin.

- 12 Using a soft metal drift, remove the secondary boom lift cylinder barrel-end pivot pin.

AWARNING Crushing hazard. The lift cylinder will fall if not properly supported.

- 13 Carefully remove the cylinder from the machine.

AWARNING Crushing hazard. The lift cylinder could become unbalanced and fall if not properly supported when removed from the machine.

CAUTION Component damage hazard. The solenoid valve can be damaged. Use caution when removing the cylinder from the machine.

Ground Controls

REV C

TMZ-34 models manufactured in the 1998 and 1999 model years (from serial number T3498-001 to T3499-769) were originally equipped with ground controls boxes containing three printed circuit boards. Machine functions are activated using push buttons on the exterior of the box.

Beginning with the 2000 model year (from serial number T3400-001 to date), the ground control box was changed to a two-board configuration. The push buttons used to activate machine functions on earlier models were replaced with a membrane overlay decal, mounted on the exterior of the box.

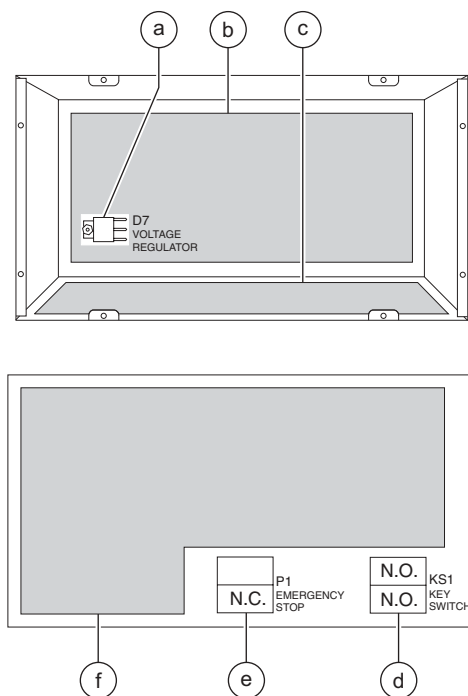

From serial number T3498-001 to T3499-769

- a voltage regulator D7
- b CPU circuit board U17
- c connector circuit board U21
- d key switch KS1
- e Emergency Stop button P2
- f key pad circuit board U15

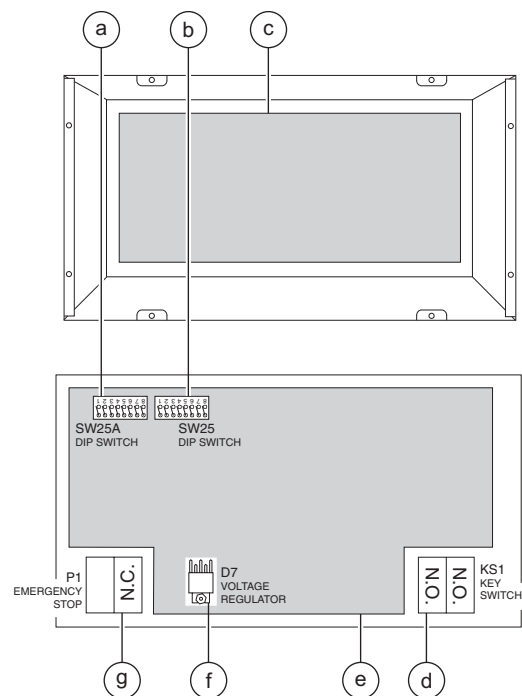

From serial number T3400-001 to date

- a DIP switch SW25A
- b DIP switch SW25
- c connector circuit board U21
- d key switch KS1
- e CPU/display circuit board U22
- f voltage regulator D7
- g Emergency Stop button P2

REV C

GROUND CONTROLS

5-1 Ground Control Keypad Circuit Board

The ground control keypad circuit board controls the machine functions from the ground. The ground control circuit board is connected to the CPU circuit board via a ribbon cable.

TMZ-34 models manufactured in the 1998 and 1999 model years (from serial number T3498-001 to T3499-769) were originally equipped with ground controls boxes containing three printed circuit boards. Machine functions are activated using push buttons on the exterior of the box.

Beginning with the 2000 model year (from serial number T3400-001 to date), the ground control box was changed to a two-board configuration. The push buttons used to activate machine functions on earlier models were replaced with a membrane overlay decal, mounted on the exterior of the box.

NOTICE The following procedure will not apply for models manufactured in the 2000 and later model years.

How to Remove the Ground Control Keypad Circuit Board

- 1 Disconnect the battery pack from the machine.

WARNING Electrocutation hazard. Contact with electrically charged circuits could result in death or serious injury. Remove all rings, watches and other jewelry.

- 2 Remove the four lid retaining fasteners from the ground control box. Open the lid.
- 3 Tag and disconnect the ribbon cables from the ground control circuit board.

CAUTION Component damage hazard. Electrostatic discharge (ESD) can damage printed circuit board components. Maintain firm contact with a metal part of the machine that is grounded at all times when handling printed circuit boards OR use a grounded wrist strap.

- 4 Remove the circuit board mounting fasteners and remove the circuit board from the ground control box lid.

CAUTION Component damage hazard. Be sure not to pinch the wires or ribbon cable when installing the lid onto the ground control box.

GROUND CONTROLS

REV C

5-2 CPU Circuit Board

The CPU circuit board controls all machine functions.

How to Remove the CPU Circuit Board

- 1 Disconnect the battery pack from the machine.

▲WARNING Electrocutation hazard. Contact with electrically charged circuits could result in death or serious injury. Remove all rings, watches and other jewelry.

- 2 Remove the four lid retaining fasteners from the ground control box. Open the lid.
- 3 Tag and disconnect all wiring from the CPU circuit board.

CAUTION Component damage hazard. Electrostatic discharge (ESD) can damage printed circuit board components. Maintain firm contact with a metal part of the machine that is grounded at all times when handling printed circuit boards OR use a grounded wrist strap.

- 4 Remove the CPU circuit board mounting fasteners and remove the CPU circuit board.

5-3 Connector Circuit Board

The connector circuit board connects the wire harness to the CPU circuit board using several cables. From serial number T3498-001 to T3499-769, the connector circuit board is equipped with a replaceable 5 amp fuse.

How to Remove the Connector Circuit Board

- 1 Disconnect the battery pack from the machine.

▲WARNING Electrocutation hazard. Contact with electrically charged circuits could result in death or serious injury. Remove all rings, watches and other jewelry.

- 2 Tag and disconnect the wire harness connectors from the ground control box.
- 3 Remove the four lid retaining fasteners from the ground control box. Open the lid.
- 4 Tag and disconnect all wiring from the connector circuit board.

CAUTION Component damage hazard. Electrostatic discharge (ESD) can damage printed circuit board components. Maintain firm contact with a metal part of the machine that is grounded at all times when handling printed circuit boards OR use a grounded wrist strap.

- 5 Remove the connector circuit board mounting fasteners and remove the connector circuit board.

REV C

GROUND CONTROLS

5-4 Software Configuration

TMZ-34 models manufactured in the 1998 and 1999 model years (from serial number T3498-001 to T3499-769) were originally equipped with ground controls boxes containing three printed circuit boards. Machine functions are activated using push buttons on the exterior of the box.

Beginning with the 2000 model year (from serial number T3400-001 to date), the ground control box was changed to a two-board configuration. The push buttons used to activate machine functions on earlier models were replaced with a membrane overlay decal, mounted on the exterior of the box.

Programming for all configurations of the the 1998 and 1999 model years (from serial number T3498-001 to T3499-769) is contained in the EPROM, which is installed into the CPU circuit board.

Beginning with the 2000 model year, the machine can be configured by changing the combination of toggles of the DIP switch mounted on the CPU circuit board.

NOTICE The following procedures will not apply for machines manufactured in the 1998 and 1999 model years.

How to Determine the DIP Switch Configuration

NOTICE A diagnostic display was incorporated into the ground controls after serial number T3402-115. The following procedure will not apply to machines before serial number T3402-116.

- 1 Turn the key switch to platform control and pull out the red Emergency Stop button to the on position at both the ground and platform controls.
 - 2 Press and hold both the secondary down button and the turntable rotate counterclockwise button at the ground controls.
- ⦿ Result: The DIP switch settings will appear in the diagnostic display.

NOTICE The display will show each toggle of the DIP switch in numerical order from 1 through 16, and whether the toggle is in the on position (01) or off position (00). For example, 0401 shown in the diagnostic display indicates that the fourth toggle is in the on position.

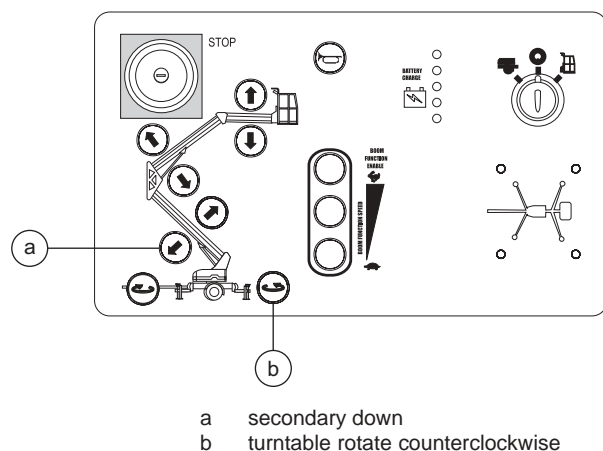

GROUND CONTROLS

REV C

How to Set the DIP Switch

- 1 Turn the key switch to the off position and push in the red Emergency Stop button to the off position at both the ground and platform controls.
- 2 Remove the fasteners securing the top to the ground controls box and open the ground control box.
- 3 Rotate the top of the ground control box to the position shown in the following illustration to correctly identify the configuration of the DIP switch settings.
- 4 Locate the DIP switch on the circuit board. Move the DIP switch settings to correspond with the configuration of the machine options as illustrated below.
- 5 Close the lid and install the fasteners.

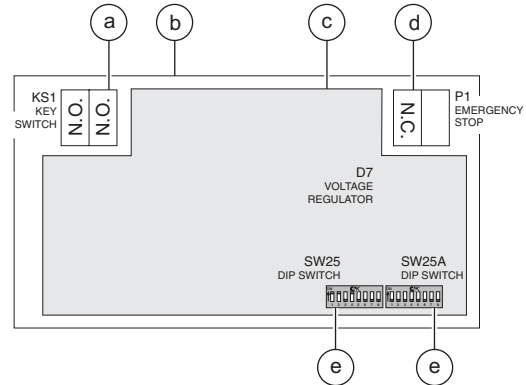

- a key switch KS1
- b ground control lid
- c CPU/display circuit board U22
- d Emergency Stop P1
- e DIP switch SW25A
- f DIP switch SW25

DIP Switch Legend

Toggle	Description	Position
1	All models	On
2	Hour meter/flashing beacon	On
3	Not used	Off
4	Outriggers hydraulic manual	Off On
5 - 16	Not used	

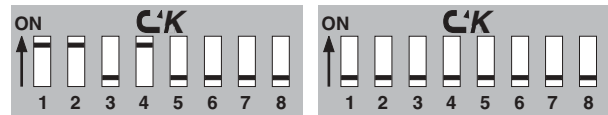

models with manual outriggers

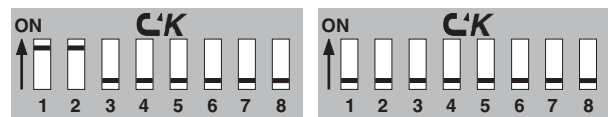

models with hydraulic outriggers

REV C

GROUND CONTROLS

5-5 Membrane Overlay

NOTICE The following procedures will not apply for machines manufactured in the 1998 and 1999 model years.

How to Replace the Overlay

- 1 Disconnect the battery pack from the machine.

AWARNING Electrocutation hazard. Contact with electrically charged circuits could result in death or serious injury. Remove all rings, watches and other jewelry.

- 2 Loosen the control box lid retaining fasteners and open the lid.

- 3 Disconnect the large blue connector from the circuit board at the connection marked **KEYPAD** by sliding the connector parallel to the circuit board.

CAUTION Component damage hazard. The circuit board will become damaged if the wire harness and connector are disconnected without proper care. Do not pull upwards on the connector OR put any weight or strain on the wires.

CAUTION Component damage hazard. Electrostatic discharge (ESD) can damage printed circuit board components. Use a grounded wrist strap at all times when handling printed circuit boards.

- 4 Install the lid onto the control box. Finger-tighten the retaining fasteners.

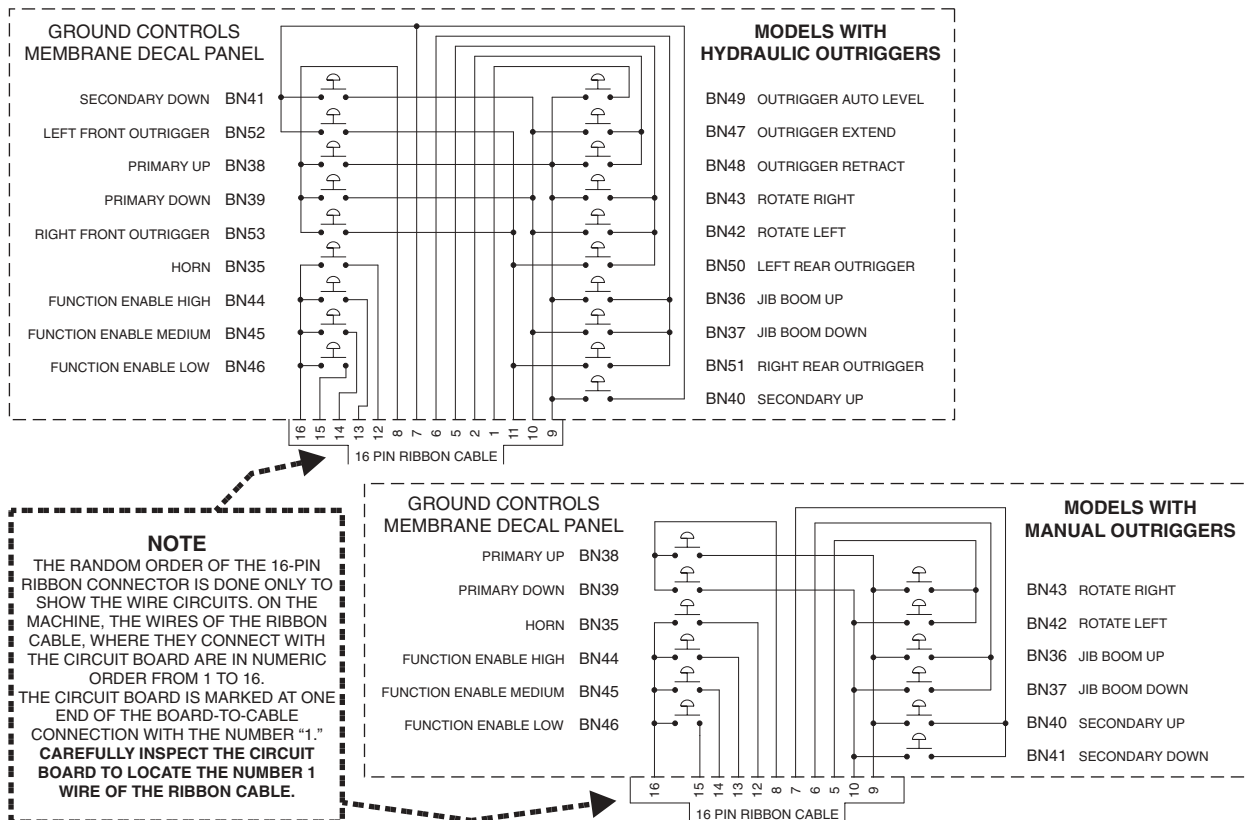

GROUND CONTROLS

REV C

- 5 Starting at the upper corners of the touch pad, remove all layers of the touch pad from the control box lid.

NOTICE The wire harness and large blue connector will interfere if removing the touch pad from the bottom.

- 6 Pull the large blue connector through the slot in the control box lid and discard the old touch pad. Remove any remaining sealant from the slot.
- 7 Using a mild solvent, clean the surface of the control box lid. Allow the surface to dry.

CAUTION Component damage hazard. The circuit board will become damaged if it comes in contact with solvent. Do not allow solvent to contact the circuit board.

- 8 Remove all the brown backing material from the new touch pad.
- 9 Insert the large blue connector from the new touch pad through the slot. Carefully align the battery power LED on the control box lid with the window in the new touch pad and lightly lay the touch pad onto the control box lid.

NOTICE Repositioning the touch pad is possible if the touch pad is lightly adhered to the lid. Do not apply any pressure to the touch pad.

- 10 When satisfied with the position of the touch pad, firmly press down the entire surface of the touch pad with your fingers.

- 11 Loosen the control box lid retaining fasteners and open the lid.

- 12 Using RTV-type sealant, completely seal the opening in the slot of the control box lid around the wire harness.

- 13 Apply dielectric grease to the pins on the circuit board at the connection marked **KEYPAD**.

- 14 Install the large blue connector onto the circuit board pins at the connection marked **KEYPAD**. Slide the connector parallel to the circuit board until the connector is pushed onto the circuit board pins no less than 0.2 inch / 5 mm.

NOTICE Be sure all pins are in the connector.

- 15 Install the lid onto the control box and tighten the retaining fasteners. Do not overtighten.

REV C

GROUND CONTROLS

5-6 Level Sensor

One level sensor monitors the incline of the turntable after the outriggers are deployed and the machine is level. The Electronic Control Module (ECM) is programmed to deactivate lift functions and activate an alarm when a signal is received from the level sensor, making the operator aware of a potentially hazardous situation.

The tilt alarm sounds when the incline of the chassis exceeds 1.5° in any direction. The tilt level sensor is located below the ground control box.

How to Install and Calibrate the Tilt Level Sensor

⚠ DANGER Tip-over hazard. Failure to install or calibrate the level sensor as instructed could result in the machine tipping over causing death or serious injury. Do not install or calibrate the level sensor other than specified in this procedure.

- 1 Perform this procedure with the machine on a firm, level surface that is free of obstructions.
 - 2 Turn the key switch to ground control and pull out the red Emergency Stop button to the on position at both the ground and platform controls.
- ⊙ Result: The power light should be on.

Models with hydraulic outriggers:

- 3 Push and hold the auto level button. Push and hold the extend outrigger button.
- ⊙ Result: The outriggers will lower and adjust to level the machine and raise the wheels slightly off the ground. Use a digital level to confirm that the machine is level.

Models with manual outriggers:

- 4 Lower and lock into place each outrigger.
 - 5 Adjust the outriggers to level the machine and raise the wheels slightly off the ground.
- ⊙ Result: The corresponding interlock display lights will be on. If the light is flashing, continue adjusting the outrigger until the light remains on.

All models:

- 6 Turn the key switch to the off position.
- 7 Locate the tilt level sensor next to the ground control box.

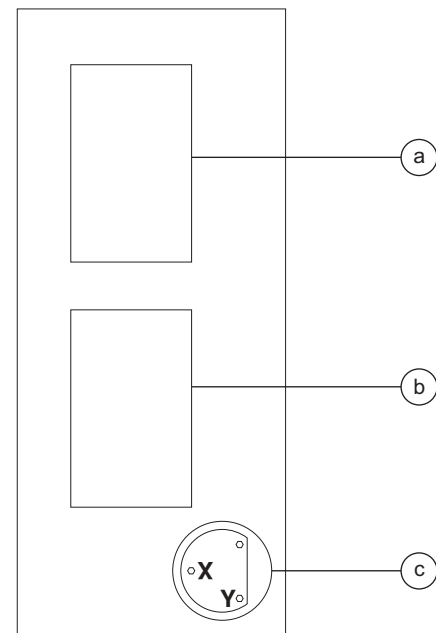

- a battery charger
b ground control box
c level sensor

GROUND CONTROLS

REV C

If you are not installing a new level sensor, proceed to step 13.

- 8 Tag and disconnect the wire harness from the tilt level sensor.
- 9 Remove the fasteners securing the level sensor to the machine. Remove the level sensor from the machine.
- 10 Install the new level sensor onto the machine with the "X" on the level sensor housing closest to the ground control box, as shown in the illustration on the previous page. Install and securely tighten the level sensor retaining fasteners.

▲ DANGER Tip-over hazard. The level sensor must be installed with the "X" on the level sensor base closest to the ground control box. Failure to install the level sensor as instructed could result in the machine tipping over causing death or serious injury.

- 11 Connect the wire harness to the level sensor.
- 12 Tighten the level sensor adjusting fasteners until the bubble in the top of the level sensor is centered in the calibration circles.
- 13 Turn the key switch to ground control.

Adjust the side-to-side axis:

- 14 Set a multimeter to read DC voltage.
- 15 Without disconnecting the wire harness from the level sensor, connect the negative lead of the multimeter to the black wire at the level sensor.
- 16 Without disconnecting the wire harness from the level sensor, connect the positive lead of the multimeter to the yellow wire at the level sensor.
- 17 Adjust the "Y" axis (side-to-side) to 2.5V DC. Tap the top of the level sensor lightly with fingers after each turn of an adjusting nut.

▲ DANGER Tip-over hazard. Do not adjust the potentiometers on the bottom of the level sensor or calibrate the level sensor other than specified in this procedure. Failure to calibrate the tilt level sensor as instructed will cause the machine to tip over resulting in death or serious injury.

NOTICE Be sure there are threads showing through the top of each adjusting nut.

- 18 Disconnect the positive lead.

REV C

GROUND CONTROLS

Adjust the front-to-back axis:

- 19 Without disconnecting the wire harness from the level sensor, connect the positive lead of the multimeter to the blue wire at the level sensor.
- 20 Adjust the "X" axis (front-to-back) to 2.5V DC. Tap the top of the level sensor lightly with fingers after each turn of an adjusting nut.

⚠ DANGER Tip-over hazard. Do not adjust the potentiometers on the bottom of the level sensor or calibrate the level sensor other than specified in this procedure. Failure to calibrate the tilt level sensor as instructed will cause the machine to tip over resulting in death or serious injury.

NOTICE Be sure there are threads showing through the top of each adjusting nut.

- 21 Disconnect the positive and negative leads.
- 22 Apply Sentry Seal to the adjusting nuts.

Test the machine:

- 23 Raise the primary, secondary and jib booms approximately 12 inches / 30 cm.
- ⦿ Result: The tilt sensor alarm should not sound.
- 24 Press down one side of the tilt sensor and place the tilt sensor test tool under one of the posts.
- ⦿ Result: The alarm, located in the platform, should sound at 180 beeps per minute after 1 second. The interlock display light should flash.
- 25 Test all machine functions.
- ⦿ Result: The primary boom up, secondary boom up and jib boom up functions should not operate. The primary boom down, secondary boom down, jib boom down and turntable rotate functions should operate normally.
- 26 Turn the key switch to platform control.
- 27 Test all machine functions.
- ⦿ Result: The primary boom up, secondary boom up and jib boom up functions should not operate. The primary boom down, secondary boom down, jib boom down and turntable rotate functions should operate normally.

GROUND CONTROLS

REV C

5-7 Interacter Battery Charger

The Interacter 24/25 battery charger, used on machines before serial number T3403-131, is a three-stage, microprocessor-controlled 24V 25A charger, with short circuit and reverse battery protection, constant current, and constant voltage with temperature compensated charging voltage.

There is no need to switch off the charger once the batteries are charged, as the charger senses the condition of the batteries and automatically switches into a float or standby mode.

The charger is protected with a 10A slow blowing fuse, located behind a small panel just below the AC input connector.

There are 7 LEDs on the front panel, any combination of which indicates the state of battery charge or charger operating condition. Listed in the next column, in order from top to bottom as seen on the charger case, is an explanation of what these LEDs indicate.

When using the charger, be sure the AC supply circuit is grounded.

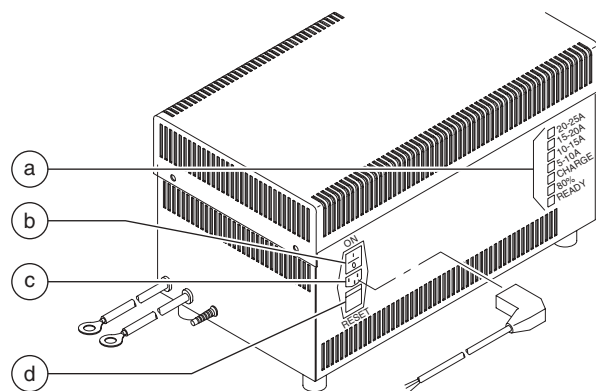

- a LEDs
- b on/off switch
- c AC input connector
- d fuse panel

Callout	LED	Description
20-25A	Red	Illuminates when charge current is 80% of chargers nominal rating.
15-20A	Red	Illuminates when charge current is 60% of chargers nominal rating.
10-15A	Red	Illuminates when charge current is 40% of chargers nominal rating.
5-10A	Red	Illuminates when charge current is 20% of chargers nominal rating.
Charge	Red	Illuminates when battery is connected correctly and AC power is present. LED turns off when battery reaches first voltage limit.
80%	Yellow	Illuminates during charging when timer is running; battery voltage is held constant at this while this LED is on, minimum one hour OR one hour plus half time required to reach first voltage limit.
Ready	Green	Illuminates at end of charging cycle, indicating batteries are charged and ready for use, and will remain on as long as AC power and batteries remain connected, maintaining charger in float or standby mode. NOTE: If the Green LED flashes constantly at the end of the charge, this indicates an override timeout fault condition, which happens if the charge cycle is not completed within 18 hours of charge start, after which the charger will not output any current. This is caused by a charger low output current fault OR a shorted cell in a battery.

Current settings	Normal	Liquid	Gel
First voltage limit	29V	31V	28V
Float / Standby	27.6V	27.7V	27.5V

REV C

GROUND CONTROLS

How to Install a Circuit Board

- 1 Disconnect the battery pack from the machine.

WARNING Electrocutation hazard. Contact with electrically charged circuits could result in death or serious injury. Remove all rings, watches and other jewelry.

- 2 Disconnect all external AC power supply from the machine.
- 3 Remove the fasteners securing the cover to the top of the battery charger. Remove the cover.
- 4 Locate the circuit board. Tag and disconnect all circuit board wiring.
- 5 Remove the circuit board.
- 6 Install the new circuit board into the battery charger. Securely install all circuit board wiring.
- 7 Set the DIP switch. Determine the type of batteries being used on the machine. Then, using the following chart, set the toggles of the DIP switch accordingly.

CAUTION Component damage hazard. Incorrectly setting the DIP switch may result in decreased battery life. Use caution when programming the circuit board.

NOTICE 'Gel' setting will increase battery life while decreasing the amount of cycles for the machine. 'Normal' setting will decrease the battery life, while increasing the amount of cycles for the machine.

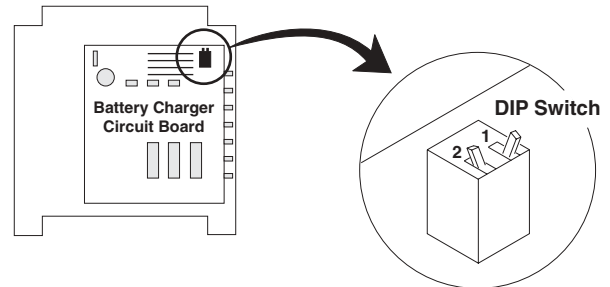

DIP switch location

- 8 Install the cover onto the battery charger. Install and securely tighten the fasteners. Do not over tighten.

DIP settings	Normal	Liquid	Gel
Toggle 1	OFF	OFF	ON
Toggle 2	ON	OFF	OFF

If not operating correctly, check the following:

- Good power supply at the AC power source
- Use only #12 AWG heavy-duty extension cord
- Power cable firmly connected to the AC input plug or fitted into the AC input connector
- Faulty fuse (120V models) or faulty circuit breakers (230V models)
- Correct wiring at the batteries:
 - Red charger wire to battery positive
 - Black charger wire to battery negative

CAUTION Component damage hazard. This charger is designed to sense battery condition and automatically switch off when the batteries are fully charged. To avoid overcharging and possible battery damage should the charger fail to turn off, disconnect the AC supply from the charger if the machine will be unattended for more than 24 hours.

GROUND CONTROLS

REV C

5-8 Lester Battery Charger

North America models: The Lester 19740 battery charger, used on machines after serial number T3403-130, is a 24V 25A charger. Designed for use with wet (liquid filled) batteries, this self-regulating charger is equipped with built-in line voltage compensation which supplies consistent DC output even when the AC supply voltage varies by as much as 10%.

This 120V AC charger is equipped with and protected by a 30A fuse, located on the charger face plate next to the AC input plug.

Worldwide models: The Lester 22310 battery charger, used on machines after serial number T3403-130, is a 24V 20A charger. Designed for use with wet (liquid filled) batteries, this self-regulating charger is equipped with built-in line voltage compensation which supplies consistent DC output even when the AC supply voltage varies by as much as 10%.

This charger, which automatically adjusts to operate on 110V or 220V AC, is equipped with and protected by three circuit breakers, located on the face plate next to the AC input connector. Two 8A circuit breakers are used on the input side of the charger circuit; one 45A circuit breaker is used on the output side.

If not operating correctly, check the following:

- Good power supply at the AC power source
- Use only #12 AWG heavy-duty extension cord
- Power cable firmly connected to the AC input plug or fitted into the AC input connector
- Faulty fuse (19740 models) or faulty circuit breakers (22310 models)
- Correct wiring at the batteries
 - Red or White charger wire to battery positive
 - Black charger wire to battery negative

CAUTION Component damage hazard. These chargers are designed to sense battery condition and automatically switch off when the batteries are fully charged. To avoid overcharging and possible battery damage should the charger fail to turn off, disconnect the AC supply from the charger if the machine will be unattended for more than 24 hours.

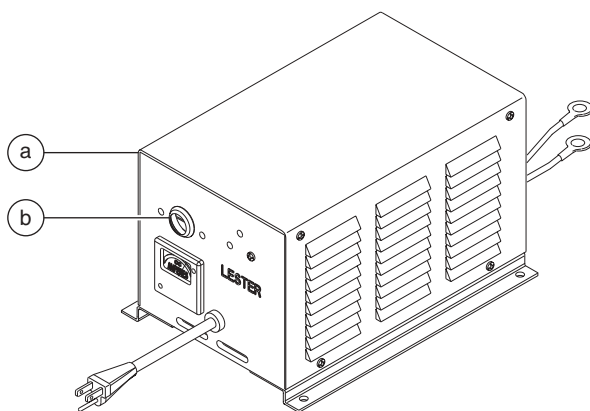

a North America model
b 30A fuse (output)

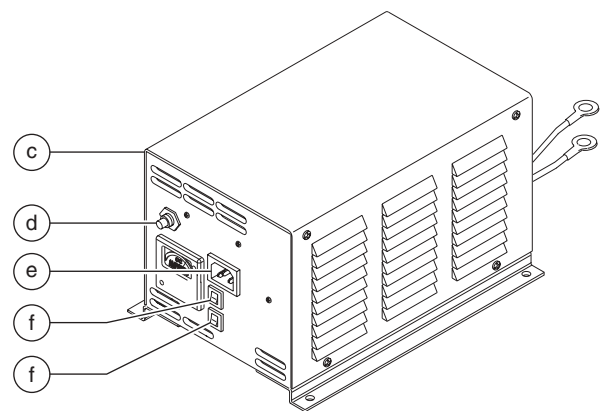

c Worldwide model
d 45A circuit breaker (output)
e AC input connector

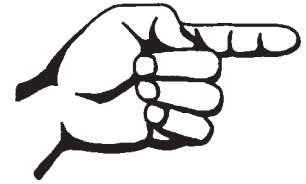

This page intentionally left blank.

Hydraulic Power Unit

REV B

6-1

Hydraulic Power Unit Components

The hydraulic power unit is located under the side cover opposite the ground control side of the machine.

Index No.	Description	Schematic Item	Function	Torque
1	Hydraulic return filter		Filters oil returning to the tank	
2	Diagnostic nipple	D	Testing	155 in-lbs / 17.5 Nm
3	Proportional valve, N.C. with manual over ride knob	E	Allows lowering of the boom	155 in-lbs / 17.5 Nm
—	Coil nut (item E)			5-7 ft-lbs / 7-9 Nm
4	24V DC electric motor		Operates hydraulic pump	
5	Motor bearing		Aligns motor shaft into pump	
6	Motor seal		Seals motor from contaminants	
7	Pressure relief valve	F	System relief	
8	Pump		0.75 gallons per minute @ 3000 psi, minimum 2.84 liters per minute @ 207 bar, minimum	
9	Pick-up filter		Filters hydraulic fluid entering the pump	
10	O-ring		Tank to pump seal	
11	Sight gauge		Hydraulic fluid level	
12	Tank		6 quarts / 5.7 liters	40 in-lbs / 4.5 Nm
13	Drain plug		Drains tank	250 in-lbs / 28 Nm
14	Breather cap		Vent tank	
15	Check valve	G	One way valve for pump output	155 in-lbs / 17.5 Nm

REV B

HYDRAULIC POWER UNIT

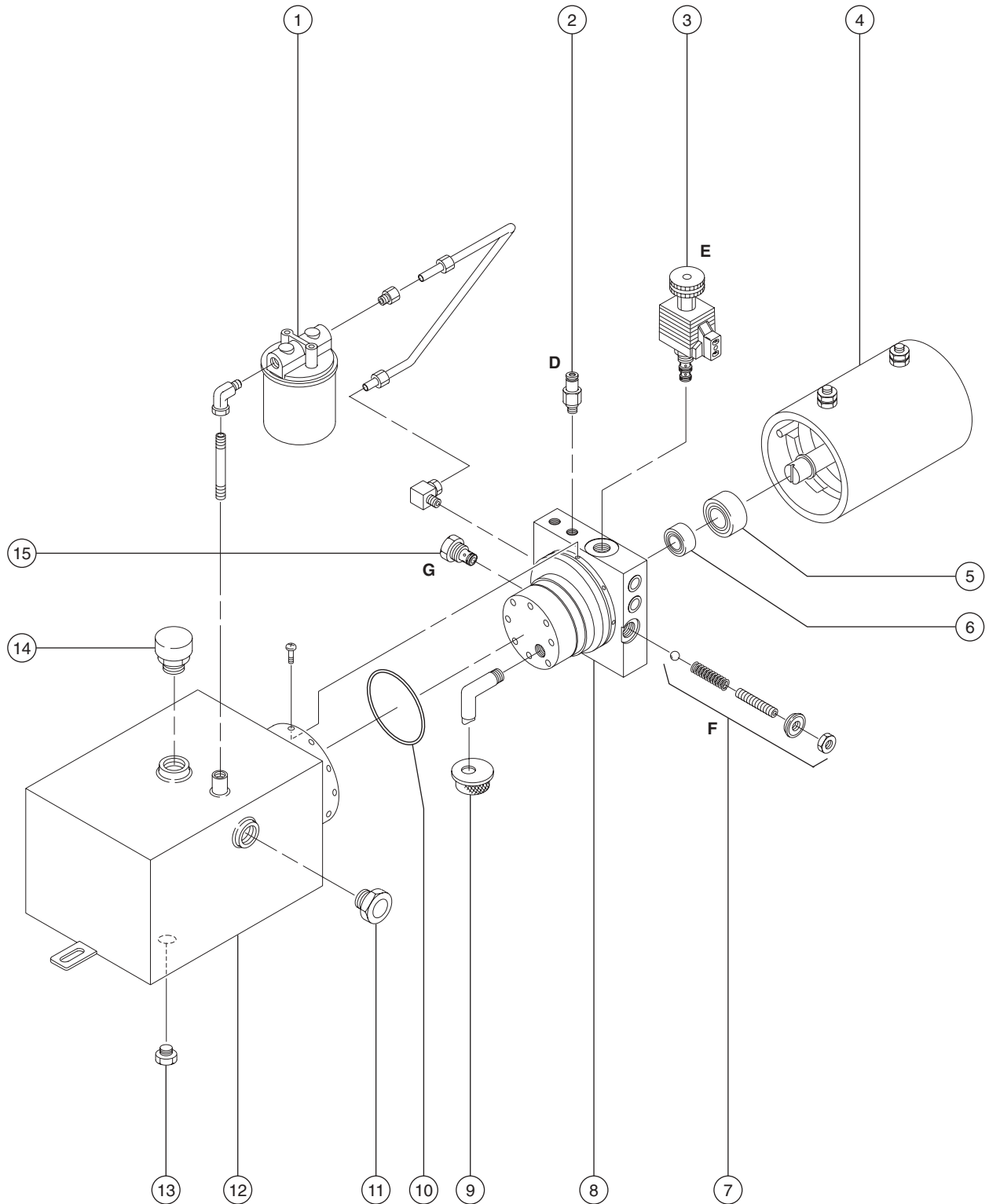

HYDRAULIC POWER UNIT

REV B

6-2 Valve Adjustments - Hydraulic Power Unit

How to Adjust the System Relief Valve

- 1 Connect a 0 to 5000 psi / 0 to 350 bar pressure gauge to the test port on the hydraulic power unit.
- 2 Turn the key switch to ground controls and pull out the red Emergency Stop button to the on position at both the ground and platform controls.
- 3 Fully raise the primary boom.

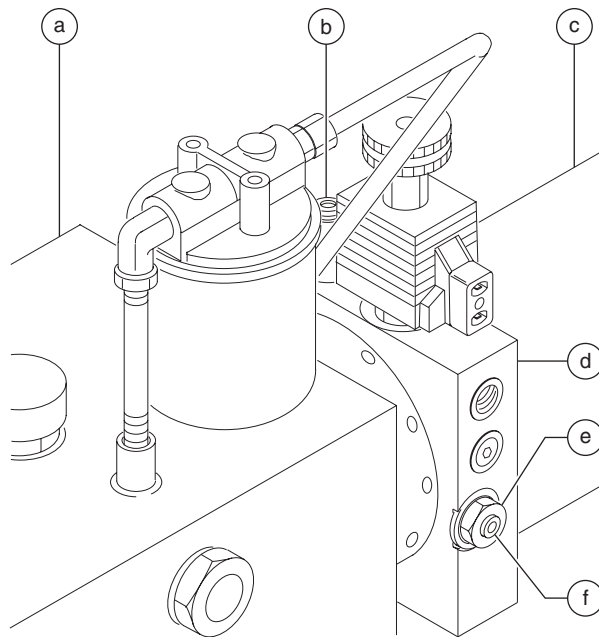

- a hydraulic tank
- b test port
- c pump motor
- d pump
- e lock nut
- f relief valve adjusting screw

- 4 Press and hold the high speed function enable button and press and hold the primary boom up button and observe the pressure reading on the pressure gauge. Turn the machine off.
- 5 Hold the relief valve adjusting screw and loosen the lock nut.
- 6 Adjust the relief valve screw. Turn it clockwise to increase the pressure or counterclockwise to decrease the pressure. Refer to Section 2, *Specifications*.

⚠ DANGER Tip-over hazard. Do not adjust the relief valve higher than specified.

- 7 Hold the relief valve screw and tighten the lock nut. Be sure the relief valve screw does not turn.
- 8 Repeat steps 2 through 4 to confirm the relief valve pressure.
- 9 Bleed the hydraulic system by raising the platform to full height. If the pump cavitates or platform fails to reach full height, add hydraulic oil until the pump is functioning correctly. Do not overfill the hydraulic tank.

⚠ CAUTION Component damage hazard. Do not continue to operate the machine if the hydraulic pump is cavitating.

REV B

HYDRAULIC POWER UNIT

6-3 Hydraulic Pump

How to Test the Hydraulic Pump

NOTICE When removing a hose assembly or fitting, the O-ring on the fitting and/or hose end must be replaced and then torqued to specification during installation. Refer to Section 2, *Hydraulic Hose and Fitting Torque Specifications*.

NOTICE Perform this procedure with the manual override knob turned fully counterclockwise to the closed position.

- 1 Tag, disconnect and plug the hydraulic hose from the high pressure port at the top of the main function pump.

WARNING Bodily injury hazard. Spraying hydraulic oil can penetrate and burn skin. Loosen hydraulic connections very slowly to allow the oil pressure to dissipate gradually. Do not allow oil to squirt or spray.

- 2 Connect a 0 to 5000 psi / 0 to 350 bar pressure gauge to the high pressure port on the pump.
- 3 Turn the key switch to ground control and pull out the red Emergency Stop button to the on position at both the ground and platform controls.

- 4 Activate a function enable button and any lift function button at the ground controls.
- ⊙ Result: If the pressure gauge reads 3000 psi / 207 bar, immediately stop. The pump is good.

CAUTION Component damage hazard. If the pressure exceeds 3000 psi / 207 bar, see 6-2, *How to Adjust the System Relief Valve*.

- ⊙ Result: If pressure fails to reach 3000 psi / 207 bar, the internal relief valve setting is incorrect OR the proportional valve is faulty OR the pump is faulty and will need to be serviced or replaced.
- 5 Remove the pressure gauge and reconnect the hydraulic hose.

HYDRAULIC POWER UNIT

REV B

How to Remove the Hydraulic Power Unit

NOTICE When removing a hose assembly or fitting, the O-ring on the fitting and/or hose end must be replaced and then torqued to specification during installation. Refer to Section 2, *Hydraulic Hose and Fitting Torque Specifications*.

- 1 Disconnect the battery pack from the machine.

WARNING Electrocutation hazard. Contact with electrically charged circuits may result in death or serious injury. Remove all rings, watches and other jewelry.

- 2 Tag, disconnect and plug the hydraulic hoses. Cap the fittings on the power unit.

WARNING Bodily injury hazard. Spraying hydraulic oil can penetrate and burn skin. Loosen hydraulic connections very slowly to allow the oil pressure to dissipate gradually. Do not allow oil to squirt or spray.

- 3 Tag and disconnect the electrical wiring from the valve coil.

- 4 Tag and disconnect the power cables from the hydraulic power unit motor.

WARNING Electrocutation hazard. Contact with electrically charged circuits may result in death or serious injury. Remove all rings, watches and other jewelry.

- 5 Remove the power unit mounting fasteners and remove the power unit from the machine.

NOTICE If a new power unit is installed, the pressure relief valve must be properly adjusted. See 6-2, *How to Adjust the System Relief Valve*.

REV B

HYDRAULIC POWER UNIT

How to Remove the Hydraulic Pump

- 1 Remove the power unit. See 6-3, *How to Remove the Hydraulic Power Unit*.
- 2 Remove the drain plug from the hydraulic tank and completely drain the tank into a suitable container. See capacity specifications.
- 3 Disconnect the hydraulic oil return line from the manifold side of the hydraulic oil filter.
- 4 Remove the hydraulic tank mounting fasteners and remove the tank from the power unit.
- 5 Remove the pump mounting fasteners and remove the pump from the motor.

CAUTION Component damage hazard. Improper alignment during assembly can damage the pump-to-motor seal. Use caution when installing the pump onto the motor.

Manifolds

REV C

7-1 Turntable Rotation Manifold Components

The turntable rotation manifold is located on the power unit side of the machine.

Index No.	Description	Schematic Item	Function	Torque
1	Solenoid valve, 3 position 4 way N.C.	H	Turntable rotate left/right	10-12 ft-lbs / 14-16 Nm
—	Coil nut (item H)			4-5 ft-lbs / 5-7 Nm
2	Relief valve	I	Turntable rotate circuit	35-40 ft-lbs / 47-54 Nm
3	Needle valve	J	Bypasses the relief valve to allow manual rotation of the turntable.	25-30 ft-lbs / 34-41 Nm

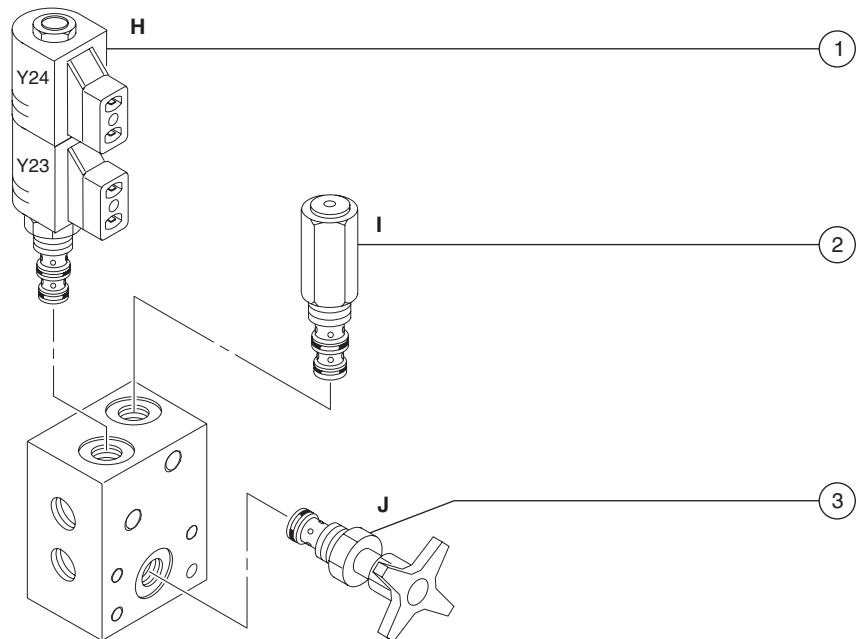

REV C

MANIFOLDS

7-2

Valve Adjustments - Turntable Rotation Manifold

How to Adjust the Turntable Rotation Relief Valve

- 1 Connect a 0 to 5000 psi / 0 to 350 bar pressure gauge to the test port on the power unit.
- 2 Turn the key switch to ground control and pull out the red Emergency Stop button to the on position at both the ground and platform controls.
- 3 Rotate the turntable in a counterclockwise direction until it rests against the turntable rotation stop.
- 4 Activate a function enable button and hold the turntable rotate left button and observe the pressure reading on the pressure gauge. Turn the machine off.
- 5 Hold the relief valve (item 1) and remove the cap.
- 6 Adjust the internal hex socket. Turn it clockwise to increase the pressure or counterclockwise to decrease the pressure. Refer to Section 2, *Specifications*.

▲ DANGER Tip-over hazard. Do not adjust the relief valve higher than specified.

- 7 Install the relief valve cap.
- 8 Repeat steps 2 through 6 to confirm the relief valve pressure.

MANIFOLDS

REV C

7-3 Outrigger Manifold Components

The outrigger manifold is located above the turntable rotation motor on the power unit side of the machine.

Index No.	Description	Schematic Item	Function	Torque
—	Coil nut (items K and L)			4-5 ft-lbs / 5-7 Nm
1	Solenoid valve, 3 position 4 way N.C.	K	Outrigger regeneration circuit	10-12 ft-lbs / 14-16 Nm
2	Solenoid valve, 3 position 4 way N.C.	L	Outrigger extend/retract	10-12 ft-lbs / 14-16 Nm

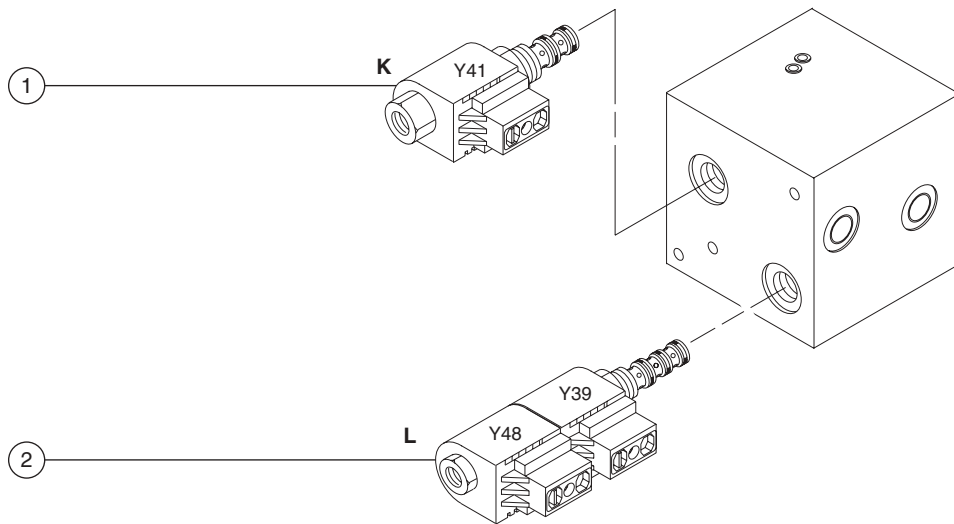

REV C

MANIFOLDS

7-4 Valve Coils

How to Test a Coil

A properly functioning coil provides an electromotive force which operates the solenoid valve. Critical to normal operation is continuity within the coil that provides this force field.

⚠ WARNING Electrocutation hazard. Contact with electrically charged circuits could result in death or serious injury. Remove all rings, watches and other jewelry.

- 1 Tag and disconnect the wire harness from the coil to be tested.
 - 2 Test the coil resistance.
- ⦿ Result: The resistance should be within specification, plus or minus 30%.
 - ⦿ Result: If the resistance is not within specification, plus or minus 30%, replace the coil.

Valve coil resistance specifications

Description	Specification
Solenoid valve, 2 position 2 way 24V DC (schematic items A, B and C)	29 - 31Ω
Proportional solenoid valve, N.C. 24V DC (schematic item E)	31.5 to 33.5Ω
Solenoid valve, 3 position 4 way N.C. 20V DC (schematic item H)	23 to 25Ω
Solenoid valve, 2 position 3 way 20V DC (schematic item K)	23 to 25Ω
Solenoid valve, 3 position 4 way N.C. 20V DC (schematic item L)	23 to 25Ω
Solenoid valve, 2 position 2 way 24V DC (schematic items M, N, O and P)	29 - 31Ω

MANIFOLDS

REV C

How to Test a Coil Diode

Genie incorporates spike suppressing diodes in all of its coils. Properly functioning coil diodes protect the electrical circuit by suppressing voltage spikes. Voltage spikes naturally occur within a function circuit following the interruption of electrical current to a coil. Faulty diodes can fail to protect the electrical system, resulting in a tripped circuit breaker or component damage.

⚠ WARNING Electrocutation hazard. Contact with electrically charged circuits could result in death or serious injury. Remove all rings, watches and other jewelry.

- 1 Test the coil for resistance. See 7-4 *How to Test a Coil*.
- 2 Connect a 10Ω resistor to the negative terminal of a known good 9V DC battery. Connect the other end of the resistor to a terminal on the coil.

NOTICE The battery should read 9V DC or more when measured across the terminals.

Resistor, 10Ω	
Genie part number	27287

- 3 Set a multimeter to read DC voltage.

NOTICE The multimeter, when set to read DC voltage, should be capable of reading up to 800 mA.

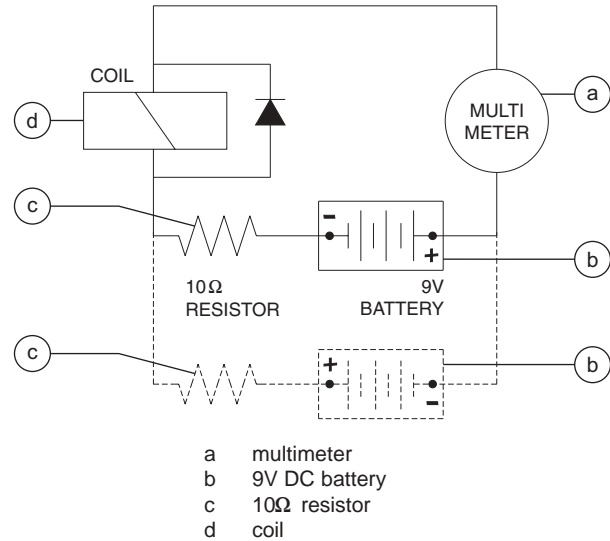

Note: Dotted lines in illustration indicate a reversed connection as specified in step 6

- 4 Connect the negative lead to the other terminal on the coil.

NOTICE If testing a single-terminal coil, connect the negative lead to the internal metallic ring at either end of the coil.

- 5 Momentarily connect the positive lead from the multimeter to the positive terminal on the 9V battery. Note and record the current reading.
 - 6 At the battery or coil terminals, reverse the connections. Note and record the current reading.
- ⊙ Result: Both current readings are greater than 0 mA and are different by a minimum of 20%. The coil is good.
 - ⊙ Result: If one or both of the current readings are 0 mA, or if the two current readings do not differ by a minimum of 20%, the coil and/or its internal diode are faulty and the coil should be replaced.

Turntable Rotation Components

REV B

8-1

Turntable Rotation Motor

How to Remove the Turntable Rotation Motor

NOTICE When removing a hose assembly or fitting, the O-ring on the fitting and/or hose end must be replaced and then torqued to specification during installation. Refer to Section 2, *Hydraulic Hose and Fitting Torque Specifications*.

- 1 Secure the turntable from rotating by securing the primary boom to the trailer tongue with the hold-down latches.
- 2 Remove the turntable rotation manifold mounting fasteners securing the manifold to the motor.
- 3 Remove the turntable rotation motor gear mounting fastener from under the turntable and remove the turntable rotation motor gear.
- 4 Remove the turntable rotation motor mounting fasteners and remove the turntable rotation motor from the machine.

Axle Components

REV B

9-1 Axle

How to Remove the Axle

- 1 Lower the outriggers and adjust to level the machine and raise the wheels off the ground.
- 2 Disconnect the parking brake cable at the tension equalizer.
- 3 Pull the parking brake cable through the mounting hole on the trailer.
- 4 Tag, disconnect and plug the brake line from the back of the hub. Cap the fitting.
- 5 Clean up any brake fluid that may have spilled.
- 6 Repeat steps 2 through 5 for the other side.
- 7 Support and secure the axle assembly to an appropriate lifting device.
- 8 Remove the axle mounting fasteners and remove the axle from the machine.

WARNING Crushing hazard. The axle could become unbalanced and fall if not properly supported and secured when removed from the machine.

NOTICE When the axle is installed, the brakes should be bled. Refer to the appropriate brake manufacturer's manual that was shipped with your Genie TMZ.

9-2 Hub and Bearings

How to Remove the Hub and Bearings

Repair procedures and additional axle information are available in the *Dexter Axle Operation Maintenance Service Manual* (Dexter part number LIT-001-00).

Dexter Axle Operation Maintenance Service Manual
Genie part number 84376

REV C

Trailer Components

10-1 Trailer Brakes

Hydraulic Brake System - ANSI Models

Repair procedures and additional axle information is available in the *Dexter Axle Operation Maintenance Service Manual* (Dexter part number LIT-001-00).

Dexter Axle Operation Maintenance Service Manual
Genie part number 84376

Electrical Brake System - ANSI Models

Repair procedures and additional axle information is available in the *Dexter Axle Operation Maintenance Service Manual* (Dexter part number LIT-001-00).

Dexter Axle Operation Maintenance Service Manual
Genie part number 84376

Mechanical Brake System - CE Models

Repair procedures and additional axle information is available in the *KNOTT Axle Service Manual* (KNOTT part number P005).

KNOTT Axle Service Manual
Genie part number 84443

10-2 Parking Brake

How to Adjust the Parking Brake

ANSI models:

- 1 Adjust the brakes. Refer to the *Dexter Axle Operation Maintenance Service Manual* (Dexter part number LIT-001-00).

Dexter Axle Operation Maintenance Service Manual
Genie part number 84376

- 2 Chock the wheels.
 - 3 Release the parking brake.
 - 4 Loosen the set screw at the side of the parking brake handle.
 - 5 Adjust the handle just to the point where it is difficult to apply the parking brake, then rotate the top of the parking brake handle counterclockwise one full turn.
 - 6 Tighten the set screw. Do not over tighten.
 - 7 Engage the parking brake. Attempt to move the machine.
- ⊙ Result: The parking brake should prevent the machine from moving. If the parking brake does not prevent the machine from moving, repeat this procedure beginning with step 1.

CE models:

Required maintenance procedures and additional axle information is available in the *KNOTT Axle Service Manual* (KNOTT part number P005).

KNOTT Axle Service Manual
Genie part number 84443

Outrigger Components

REV B

11-1 Outrigger Components

How to Remove an Outrigger

Outriggers are essential to safe machine operation and machine stability. Operating a machine with a damaged or improperly operating outrigger will result in death or serious injury.

NOTICE Perform this procedure with the parking brake applied, outriggers in the stowed position and the machine disconnected from the tow vehicle.

Models with manual outriggers, platform end:

- 1 Attach a lifting strap from an overhead crane to the pad-end of the outrigger. Do not apply any lifting pressure.
- 2 Remove the external snap ring and washer from the outrigger pivot pin.
- 3 Remove the pin retaining fastener from the outrigger pivot pin. Do not remove the pin.
- 4 Gently tap the outrigger pivot pin towards the axle using a soft metal drift until the end of the pin is almost flush with the plastic outrigger switch guide.
- 5 Place a rod through the hole in the pin and twist to remove the pin. Remove the outrigger pivot pin from the machine.

WARNING Crushing hazard. The outrigger may fall if not properly supported when the outrigger pivot pin is removed from the machine.

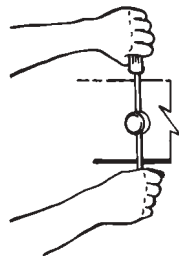

Models with manual outriggers, tongue end:

- 1 Attach a lifting strap from an overhead crane to the pad end of the outrigger. Do not apply any lifting pressure.
- 2 Remove the external snap ring and washer from the outrigger pivot pin.
- 3 Remove the pin retaining fastener from the outrigger pivot pin. Do not remove the pin.
- 4 Use a soft metal drift to remove the outrigger pivot pin. Remove the outrigger from the machine.

WARNING Crushing hazard. The outrigger may fall if not properly supported when the outrigger pivot pin is removed from the machine.

REV B

OUTRIGGER COMPONENTS

Models with hydraulic outriggers:

- 1 Attach a lifting strap from an overhead crane to the pad end of the outrigger. Do not apply any lifting pressure.
- 2 Tag and disconnect the wire harness from the outrigger limit switch.
- 3 Remove the pin retaining fasteners from the outrigger pivot pin. Do not remove the pin.
- 4 Remove the pin retaining fasteners from the outrigger cylinder rod-end pivot pin.
- 5 Place a rod through the hole in the outrigger cylinder rod-end pivot pin and twist to remove the pin. Remove the outrigger cylinder rod-end pivot pin from the machine.
- 6 Secure the rod-end of the cylinder to the chassis.
- 7 Place a rod through the hole in the outrigger pivot pin and twist to remove the pin. Remove the outrigger pivot pin from the machine.

▲WARNING Crushing hazard. The outrigger could fall if not properly supported when the pivot pin is removed from the machine.

▲WARNING Crushing hazard. The outrigger cylinder could fall if not properly supported when the outrigger is removed from the machine.

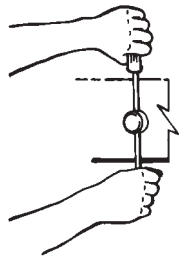

11-2 Outrigger Cylinder

How to Remove an Outrigger Cylinder

NOTICE When removing a hose assembly or fitting, the O-ring on the fitting and/or hose end must be replaced and then torqued to specification during installation. Refer to Section 2, *Hydraulic Hose and Fitting Torque Specifications*.

- 1 Extend the outrigger until the pad just touches the ground. Do not rest the weight of the machine on the outrigger.
- 2 Remove the cylinder guard mounting fasteners from the rod end of the outrigger cylinder and remove the cylinder guard from the machine.
- 3 Tag and disconnect the wire harness from the outrigger cylinder valve coil.
- 4 Tag, disconnect and plug the hydraulic hoses from the outrigger cylinder. Cap the fittings on the cylinder.

▲WARNING Bodily injury hazard. Spraying hydraulic oil can penetrate and burn skin. Loosen hydraulic connections very slowly to allow the oil pressure to dissipate gradually. Do not allow oil to squirt or spray.

OUTRIGGER COMPONENTS

REV B

- 5 Attach a lifting strap from an overhead crane to the lug on the rod end of the cylinder.
- 6 Remove the pin retaining fasteners from outrigger cylinder rod-end pivot pin.
- 7 Place a rod through the hole in the outrigger cylinder rod-end pivot pin and twist to remove the pin. Remove the outrigger cylinder rod-end pivot pin from the machine.
- 8 Raise the cylinder to a vertical position.
- 9 Remove the pin retaining fasteners from the outrigger cylinder barrel-end pivot pin.
- 10 Place a rod through the hole in the outrigger cylinder barrel-end pivot pin and twist to remove the pin. Remove the outrigger cylinder barrel-end pivot pin from the machine.

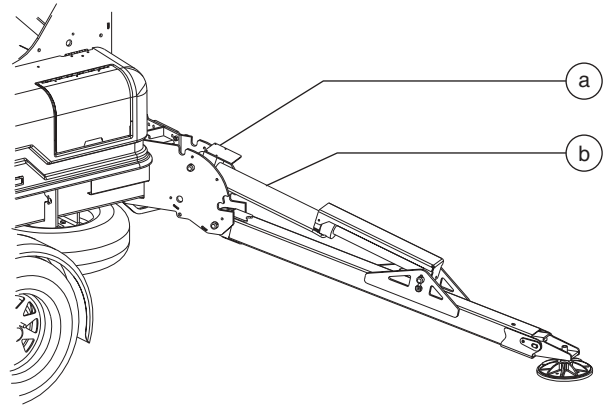

- a valve coil (hidden from view)
b outrigger cylinder

WARNING Crushing hazard. The outrigger cylinder could fall if not properly supported when the pivot pin is removed from the machine.

CAUTION Component damage hazard. The solenoid valve can be damaged. Use caution when removing the cylinder from the machine.

Troubleshooting Flow Charts



Observe and Obey:

- ☑ Troubleshooting and repair procedures shall be completed by a person trained and qualified on the repair of this machine.
- ☑ Immediately tag and remove from service a damaged or malfunctioning machine.
- ☑ Repair any machine damage or malfunction before operating the machine.
- ☑ Unless otherwise specified, perform each repair procedure with the machine in the following configuration:
 - Machine disconnected from tow vehicle
 - Machine parked on a firm, level surface with the boom stowed and both latches secured
 - Key switch in the off position with the key removed
 - The red Emergency Stop button in the off position at both ground and platform controls
 - Wheels chocked and parking brake applied
 - All external AC power supply disconnected from the machine

Before Troubleshooting:

- ☑ Read, understand and obey the safety rules and operating instructions in the appropriate operator's manual on your machine.
- ☑ Be sure that all necessary tools and test equipment are available and ready for use.
- ☑ Read each appropriate flow chart thoroughly. Attempting shortcuts may produce hazardous conditions.
- ☑ Be aware of the following hazards and follow generally accepted safe workshop practices.

⚠ DANGER Crushing hazard. When testing or replacing any hydraulic component, always support the structure and secure it from movement.

⚠ WARNING Electrocutation hazard. Contact with electrically charged circuits could result in death or serious injury. Remove all rings, watches and other jewelry.

⚠ WARNING Bodily injury hazard. Spraying hydraulic oil can penetrate and burn skin. Loosen hydraulic connections very slowly to allow the oil pressure to dissipate gradually. Do not allow oil to squirt or spray.

NOTICE Perform all troubleshooting on a firm, level surface.

NOTICE Two persons will be required to safely perform some troubleshooting procedures.

TROUBLESHOOTING FLOW CHARTS

About This Section

When a malfunction is discovered, the flow charts in this section will help a service professional pinpoint the cause of the problem. To use this section, basic hand tools and certain pieces of test equipment are required—voltmeter, ohmmeter, pressure gauges.

The location of terminals mentioned in this section can be found on the appropriate electrical or hydraulic schematics provided in Section 6, *Schematics*.

Since various degrees of a particular function loss may occur, selecting the appropriate flow chart may be troublesome. When a function will not operate with the same speed or power as a machine in good working condition, refer to the flow chart which most closely describes the problem.

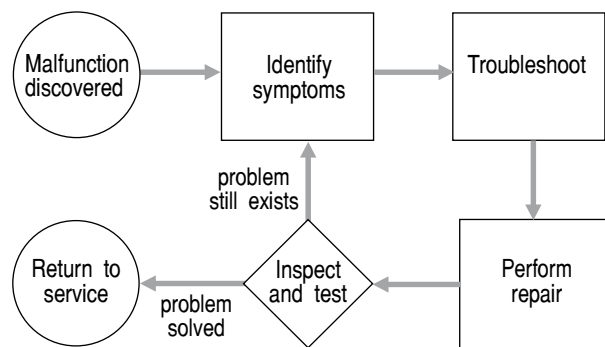
General Repair Process**LED Diagnostic Readout**

A diagnostic display was incorporated into the side of the ground controls after serial number T3402-115.

The diagnostic readout displays numerical codes that provide information about the machine operating status and about malfunctions. The numbers will blink with fault codes and the 4 dashes will remain on during normal operation.

The codes listed in the Fault Code Chart describe malfunctions and can aid in troubleshooting the machine by pinpointing the area or component affected.

Fault Code Chart

(after serial number T3402-115)

REV A

Fault Code	Fault	Condition	Possible Cause	Solution
— — — —		Normal operation		
0001	Safety circuit fault	Outriggers up, no retract structure switches	Faulty switches OR faulty harness OR faulty circuit board	Repair or replace switches or harness OR replace CPU board
0002	Negative angle boom switch fault	Outrigger up, no negative angle switch	Faulty switch OR faulty harness OR faulty circuit board	Repair or replace switch or harness OR replace CPU board
0003	Down only mode	Lift and rotate functions disabled	Machine out of level OR low battery voltage OR faulty outrigger switches	Level machine OR charge batteries OR replace outrigger switches OR consult Genie Industries Service Department
0009	Level sensor fault	Machine out of level	Machine out of level OR faulty wire harness OR faulty level sensor OR faulty circuit board	Level machine OR repair or replace wire harness or connections OR replace outrigger switches OR consult Genie Industries Service Department
0010	ECM/platform communications fault	Machine functions inoperative	Faulty control cable OR faulty circuit board	Repair or replace control cable OR replace circuit boards
0011	Platform key pad fault	Machine functions inoperative	Platform controls has stuck or faulty button	Replace platform key pad or touch pad OR replace circuit boards
0012	ECM/drive communications fault	No drive communication	Open or short in control cable OR faulty circuit boards	Repair or replace control cable OR replace circuit boards
0015	Ground keypad fault	Machine functions inoperative	Ground controls has stuck or faulty button	Replace ground key pad or touch pad OR replace circuit boards
0021	Lower boom up coil fault	Secondary up valve coil open	Coil not connected to wire harness OR open circuit OR faulty circuit board	Restore connection OR replace circuit board
0022	Lower boom up coil fault	Secondary up valve coil shorted	Short in wire harness OR faulty circuit board	Repair faulty wiring OR replace circuit board



Continued on next page

FAULT CODE CHART (AFTER SERIAL NUMBER T3402-115)

REV A

Fault Code	Fault	Condition	Possible Cause	Solution
0025	Upper boom up coil fault	Primary up valve coil open	Coil not connected to wire harness OR open circuit OR faulty circuit board	Restore connection OR replace circuit board
0026	Upper boom up coil fault	Primary up valve coil shorted	Short in wire harness OR faulty circuit board	Repair faulty wiring OR replace circuit board
0029	Outrigger up coil fault	Outrigger up valve coil open	Coil not connected to wire harness OR open circuit OR faulty circuit board	Restore connection OR replace circuit board
0030	Outrigger up coil fault	Outrigger up valve coil shorted	Short in wire harness OR faulty circuit board	Repair faulty wiring OR replace circuit board
0031	Outrigger level coil fault	Outrigger level valve coil open	Coil not connected to wire harness OR open circuit OR faulty circuit board	Restore connection OR replace circuit board
0032	Outrigger level coil fault	Outrigger level valve coil shorted	Short in wire harness OR faulty circuit board	Repair faulty wiring OR replace circuit board
0033	Outrigger regen coil fault	Outrigger regen valve coil open	Coil not connected to wire harness OR open circuit OR faulty circuit board	Restore connection OR replace circuit board
0034	Outrigger regen coil fault	Outrigger regen valve coil shorted	Short in wire harness OR faulty circuit board	Repair faulty wiring OR replace circuit board
0035	Left front outrigger coil fault	LF outrigger valve coil open	Coil not connected to wire harness OR open circuit OR faulty circuit board	Restore connection OR replace circuit board
0036	Left front outrigger coil fault	LF outrigger valve coil shorted	Short in wire harness OR faulty circuit board	Repair faulty wiring OR replace circuit board
0037	Right front outrigger coil fault	RF outrigger valve coil open	Coil not connected to wire harness OR open circuit OR faulty circuit board	Restore connection OR replace circuit board
0038	Right front outrigger coil fault	RF outrigger valve coil shorted	Short in wire harness OR faulty circuit board	Repair faulty wiring OR replace circuit board

REV A

FAULT CODE CHART (AFTER SERIAL NUMBER T3402-115)

Fault Code	Fault	Condition	Possible Cause	Solution
0039	Left rear outrigger coil fault	LR outrigger valve coil open	Coil not connected to wire harness OR open circuit OR faulty circuit board	Restore connection OR replace circuit board
0040	Left rear outrigger coil fault	LR outrigger valve coil shorted	Short in wire harness OR faulty circuit board	Repair faulty wiring OR replace circuit board
0041	Right rear outrigger coil fault	RR outrigger valve coil open	Coil not connected to wire harness OR open circuit OR faulty circuit board	Restore connection OR replace circuit board
0042	Right rear outrigger coil fault	RR outrigger valve coil shorted	Short in wire harness OR faulty circuit board	Repair faulty wiring OR replace circuit board
0045	Rotate right (clockwise) coil fault	Rotate right valve coil open	Coil not connected to wire harness OR open circuit OR faulty circuit board	Restore connection OR replace circuit board
0046	Rotate right (clockwise) coil fault	Rotate right valve coil shorted	Short in wire harness OR faulty circuit board	Repair faulty wiring OR replace circuit board
0047	Rotate left (counterclockwise) coil fault	Rotate left valve coil open	Coil not connected to wire harness OR open circuit OR faulty circuit board	Restore connection OR replace circuit board
0048	Rotate left (counterclockwise) coil fault	Rotate left valve coil shorted	Short in wire harness OR faulty circuit board	Repair faulty wiring OR replace circuit board
0049	Jib up coil fault	Jib up valve coil open	Coil not connected to wire harness OR open circuit OR faulty circuit board	Restore connection OR replace circuit board
0050	Jib up coil fault	Jib up valve coil shorted	Short in wire harness OR faulty circuit board	Repair faulty wiring OR replace circuit board
0091	Proportional valve coil fault	Proportional valve coil open	Coil not connected to wire harness OR open circuit OR faulty circuit board	Restore connection OR replace circuit board
0092	Proportional valve coil fault	Proportional valve coil shorted	Short in wire harness OR faulty circuit board	Repair faulty wiring OR replace circuit board

Chart 1

REV B

All Functions Will Not Operate (before serial number T3400-001)

Be sure the 5A fuse inside the ground controls box is not blown.

Be sure that all of the connectors and ribbon cables inside the ground control box are properly connected.

Be sure the key switch is in the appropriate position.

Be sure that both red Emergency Stop buttons are pulled out to the on position.

Be sure the batteries are fully charged.

Be sure the unit is set up according to the operator's manual.

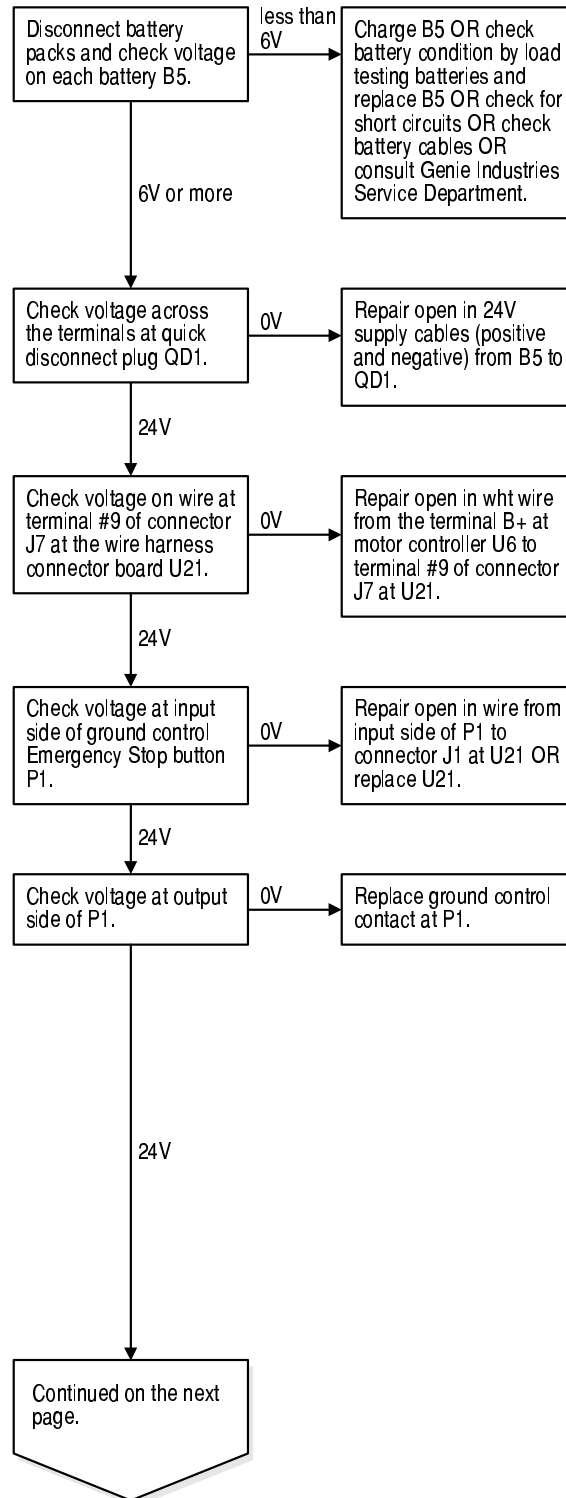

REV B

CHART 1

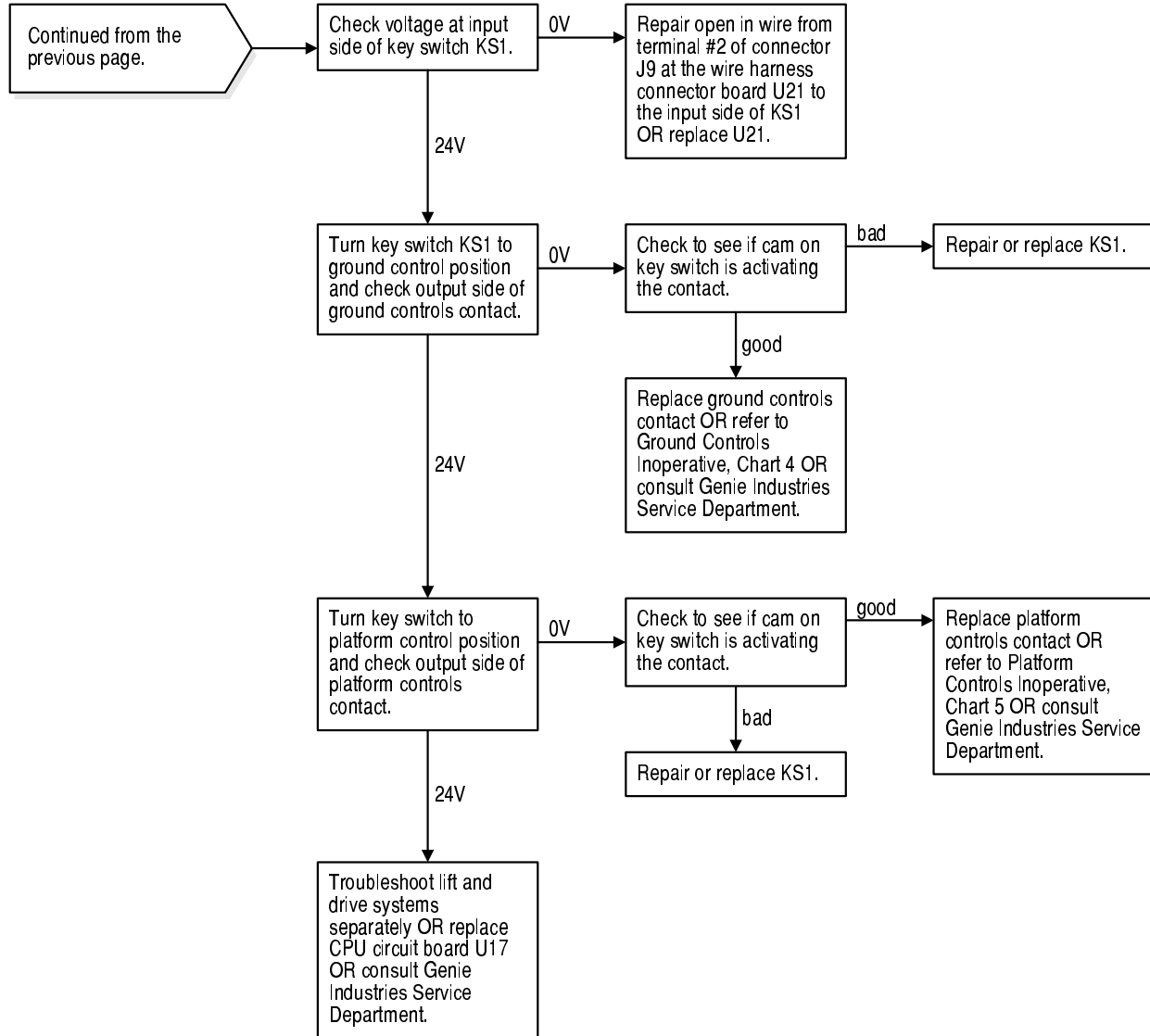

Chart 2

REV B

Pump Motor Will Not Operate

Be sure the batteries are properly connected.

Be sure the batteries are fully charged.

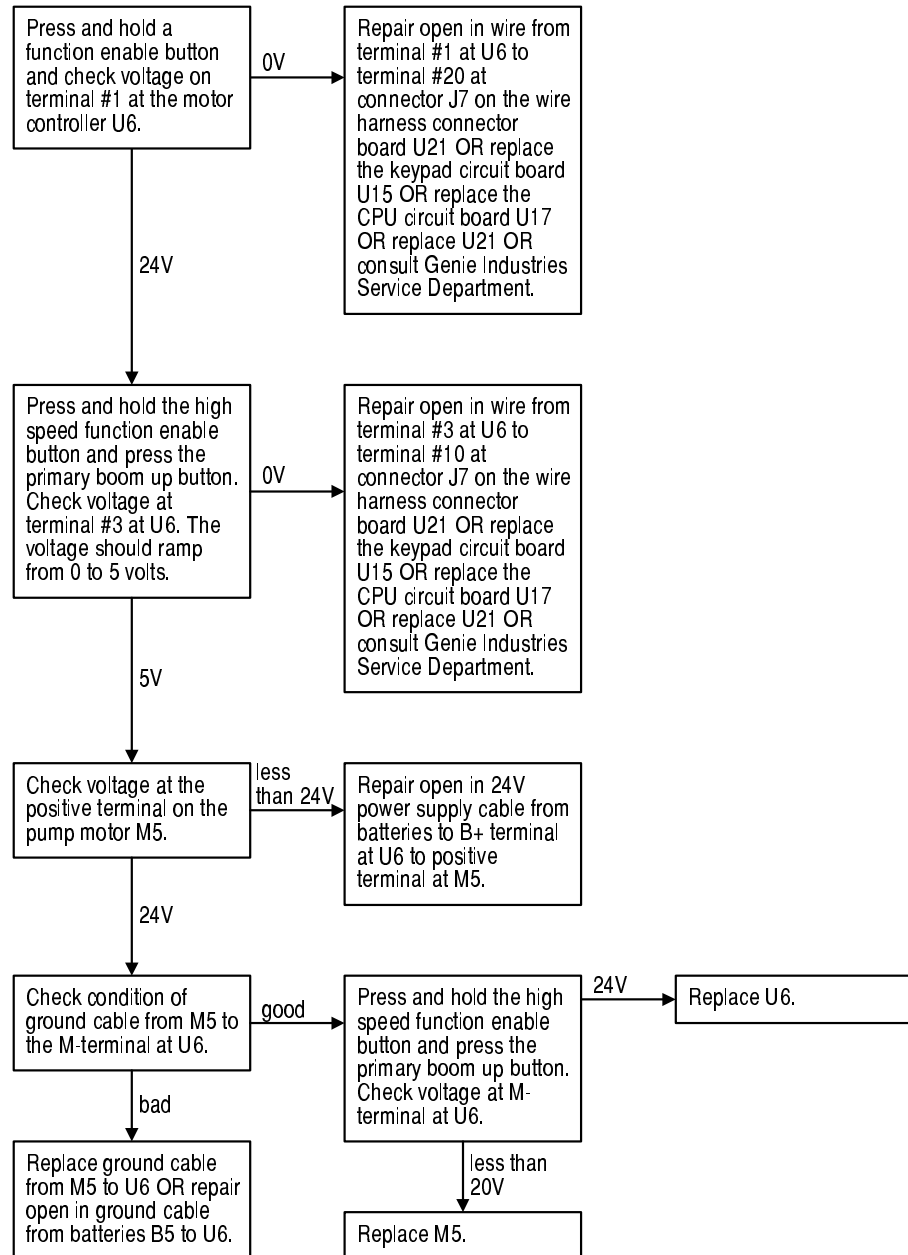

Chart 3

REV B

All Functions Inoperative, Power Unit Starts and Runs

Be sure that the manual override knob on the proportional valve on the power unit is turned counterclockwise in the closed position.

Be sure the hydraulic tank is full.

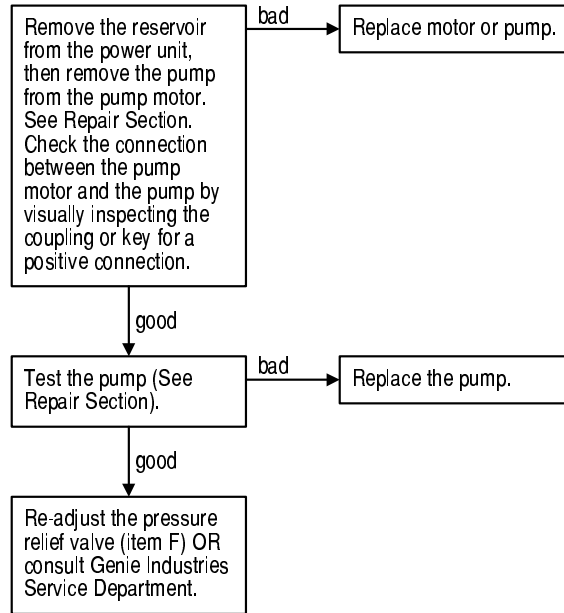

Chart 4

REV B

Ground Controls Inoperative

Be sure the key switch is turned to ground control.

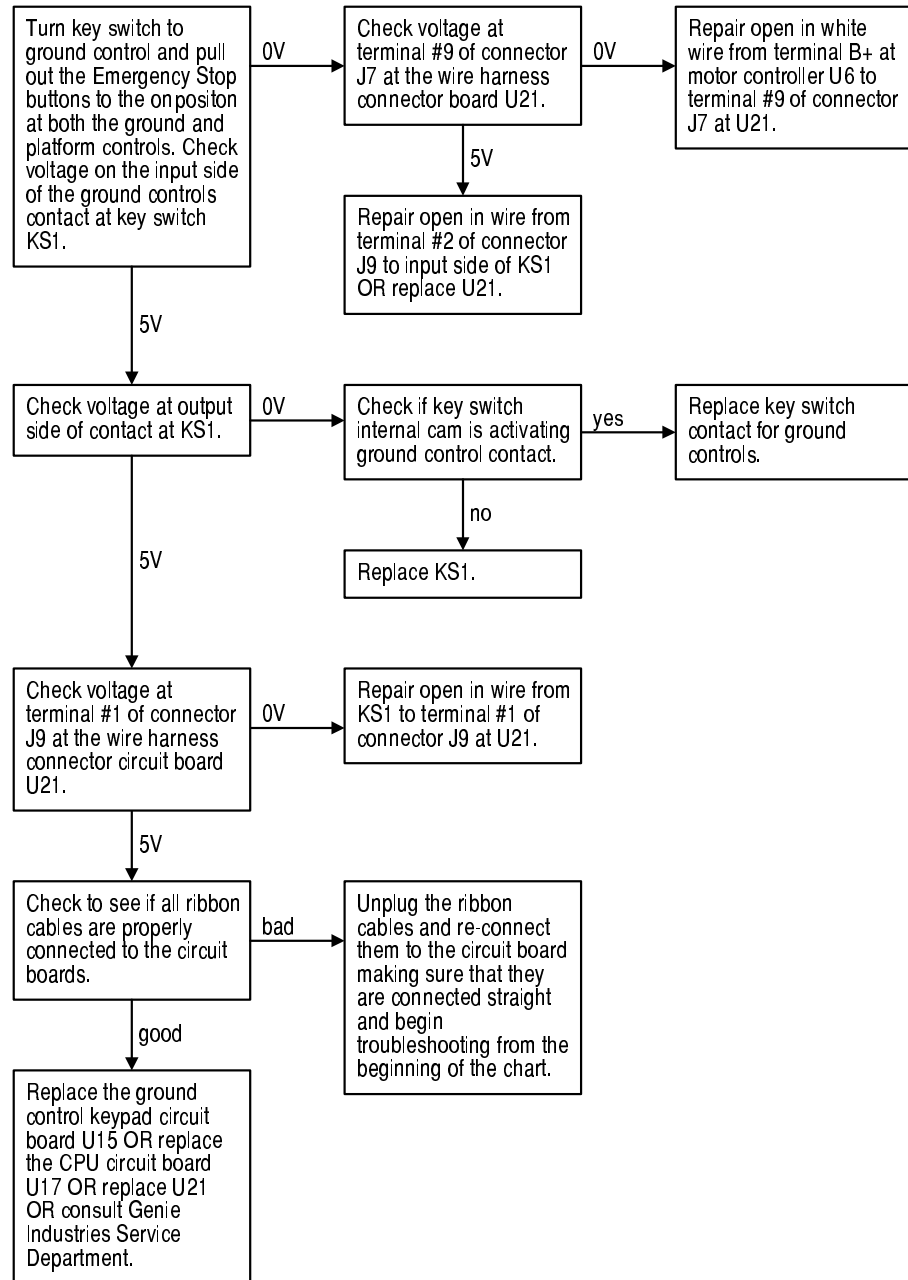

Chart 5

REV B

Platform Controls Inoperative

Be sure all cables from turntable through the boom linkage are in good condition with no kinks or abrasions.

Be sure the key switch is turned to platform control.

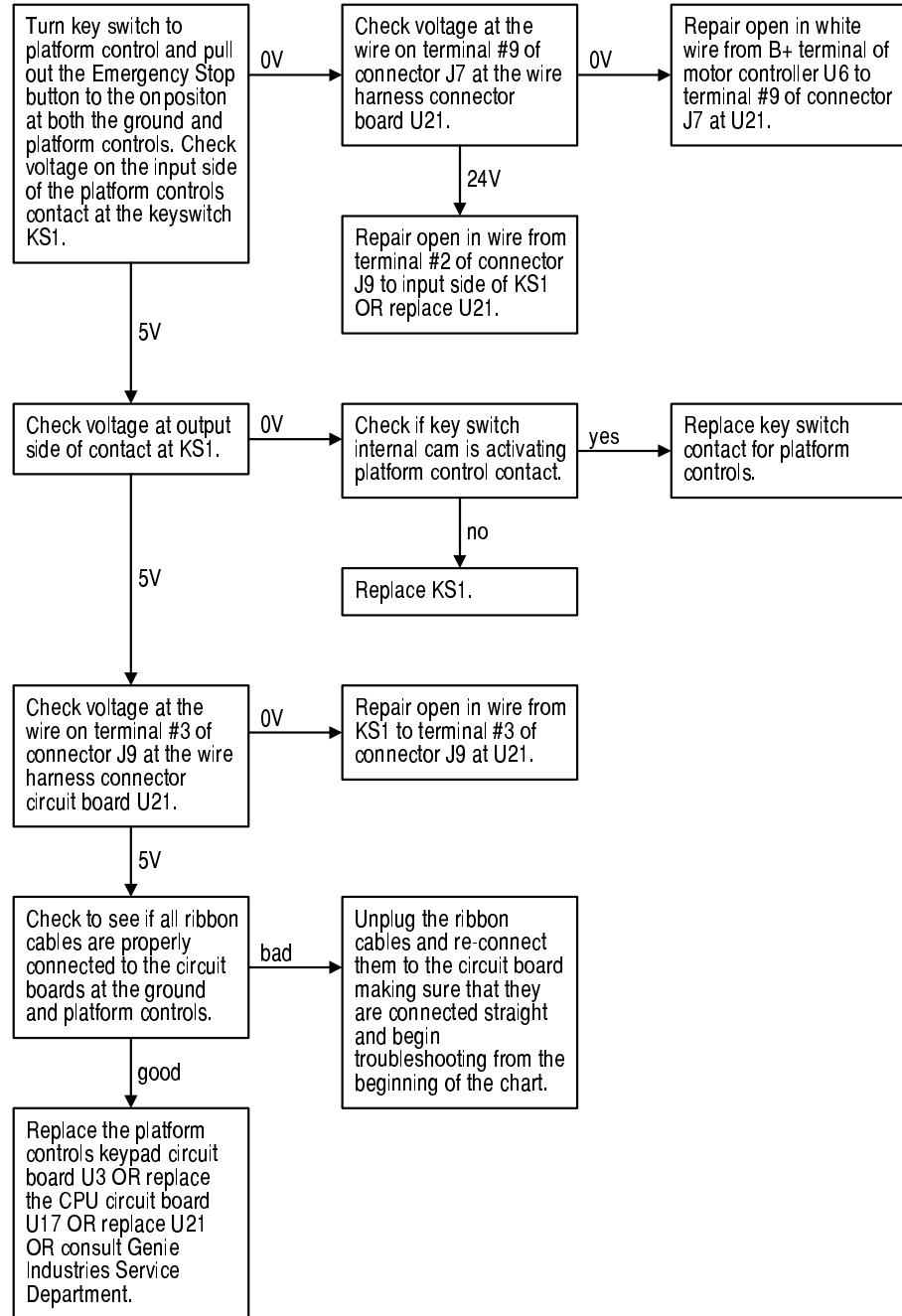

Chart 6

REV B

Jib Boom Up Function Inoperative

Be sure all other functions operate normally.

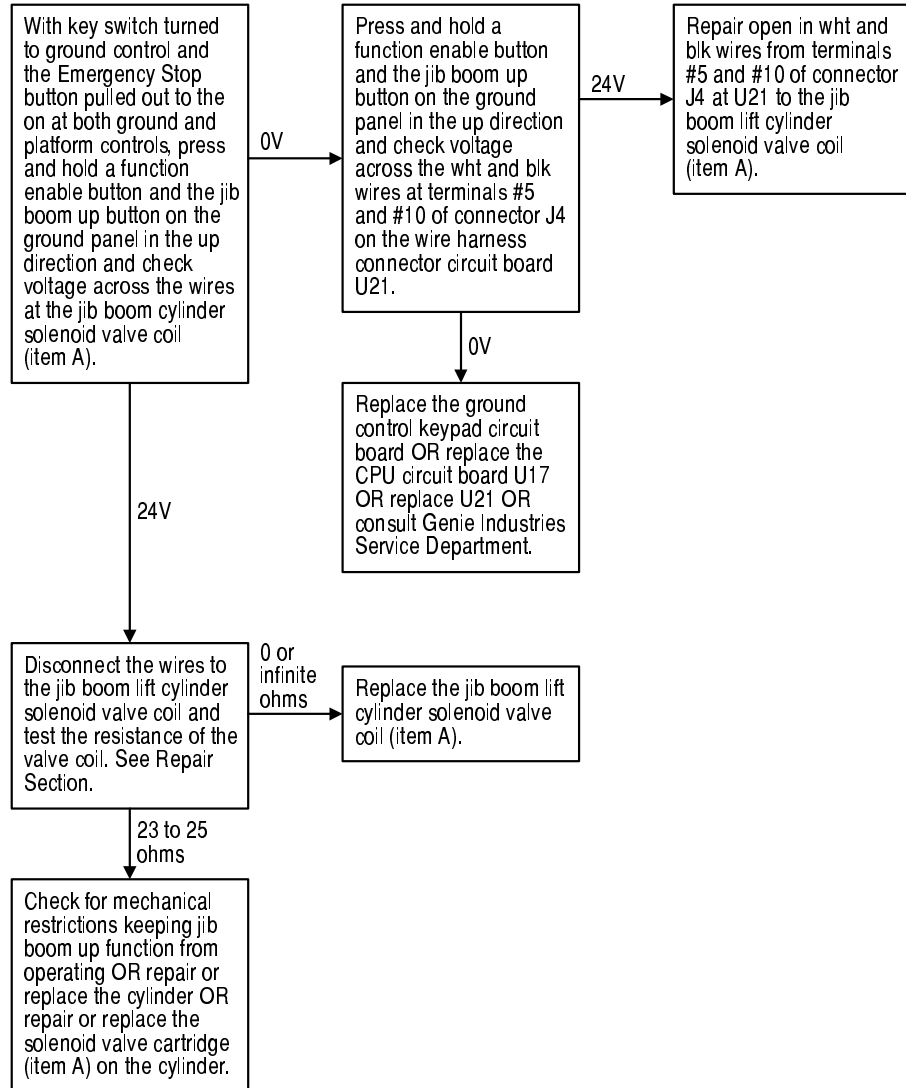

Chart 7

REV B

Jib Boom Down Function Inoperative

Be sure all other functions operate normally.

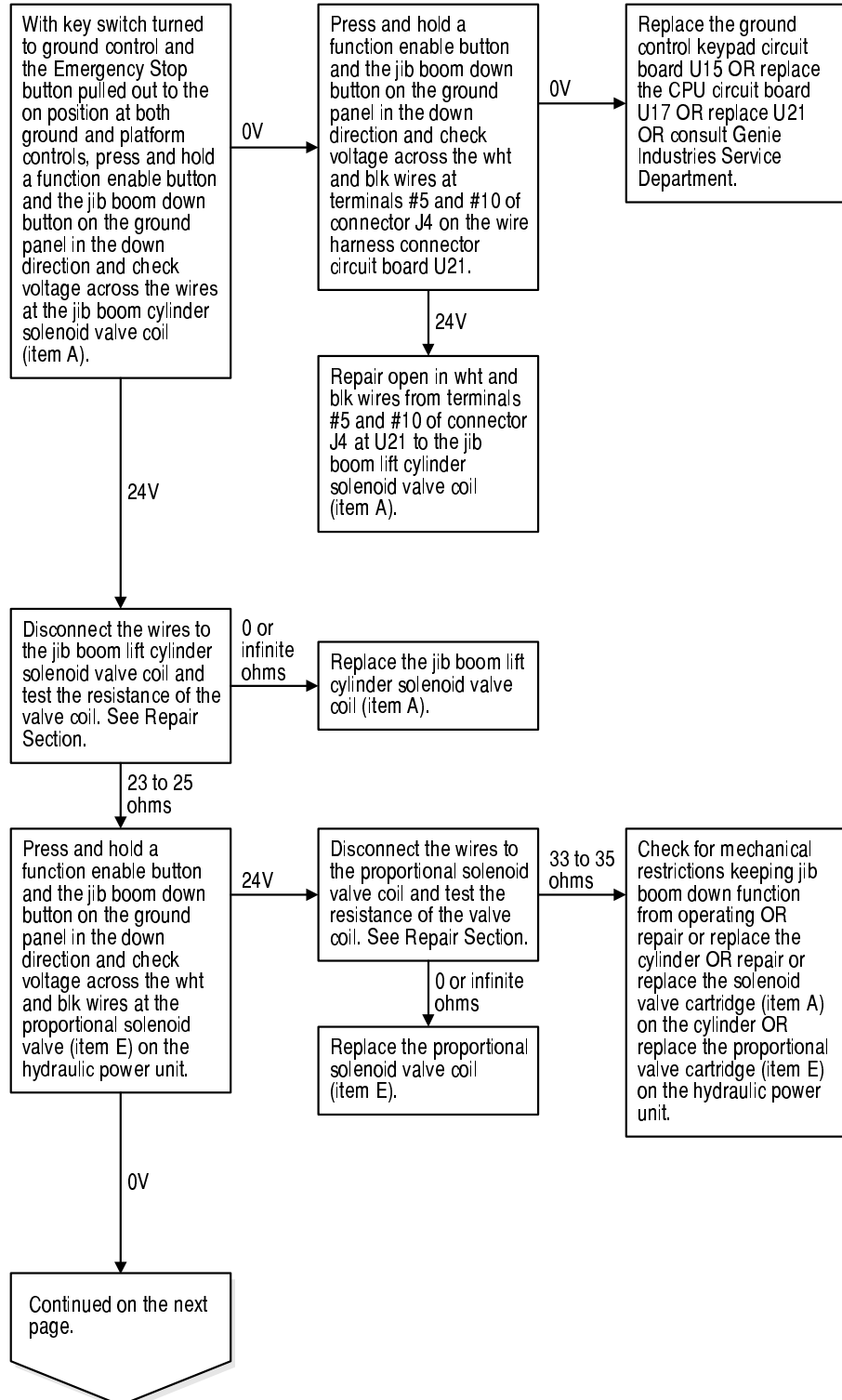

CHART 7

REV B

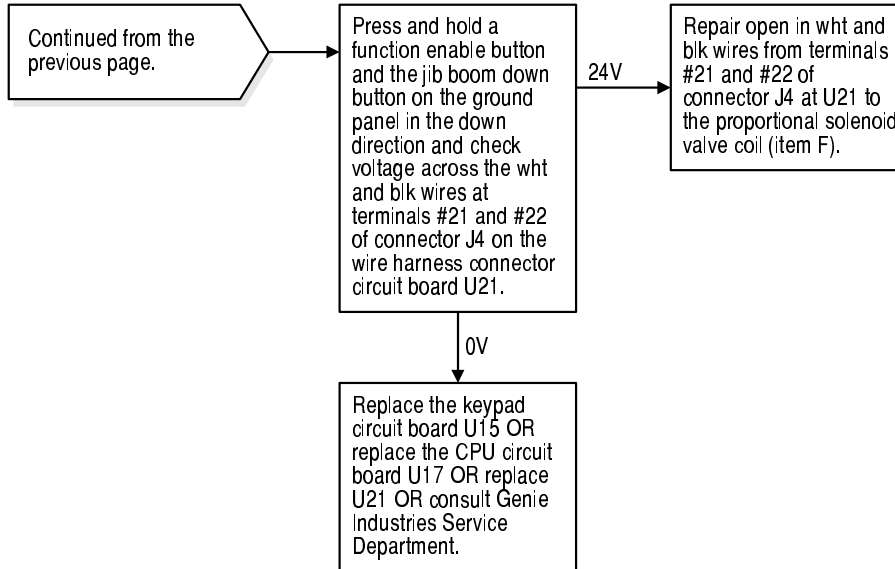

Chart 8

REV B

Primary Boom Up Function Inoperative

Be sure all other functions operate normally.

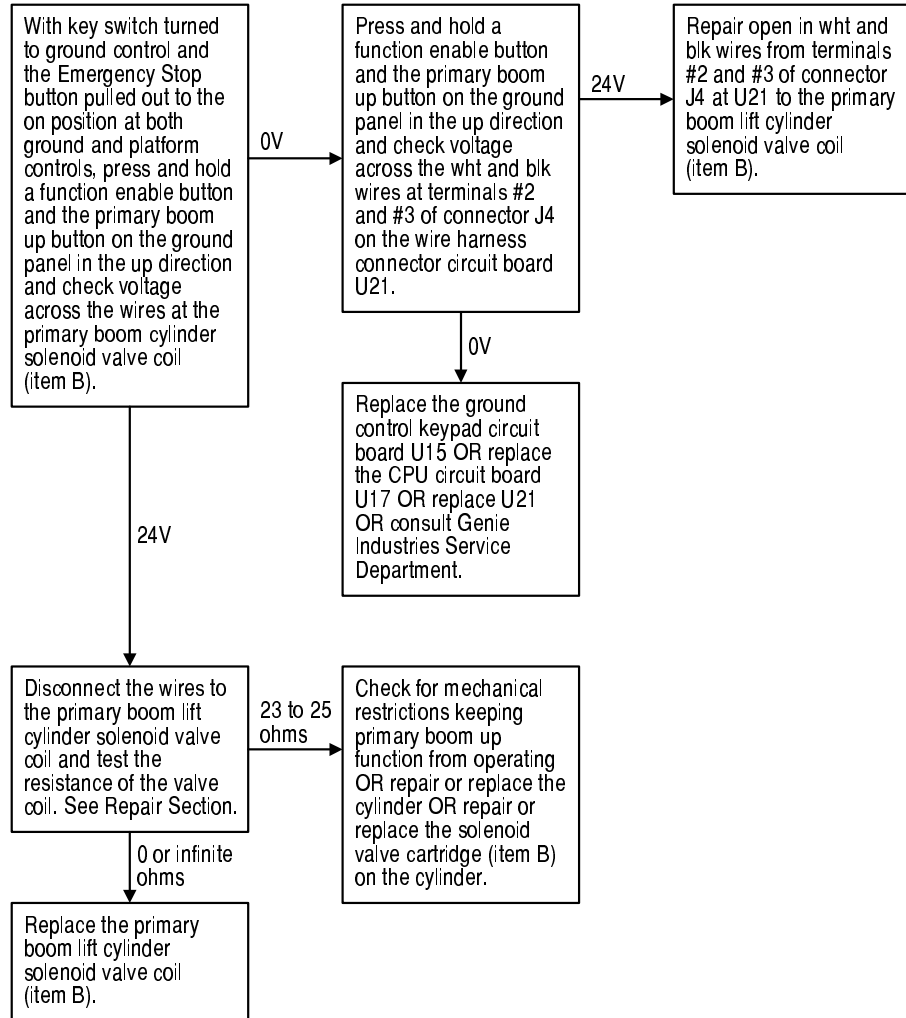
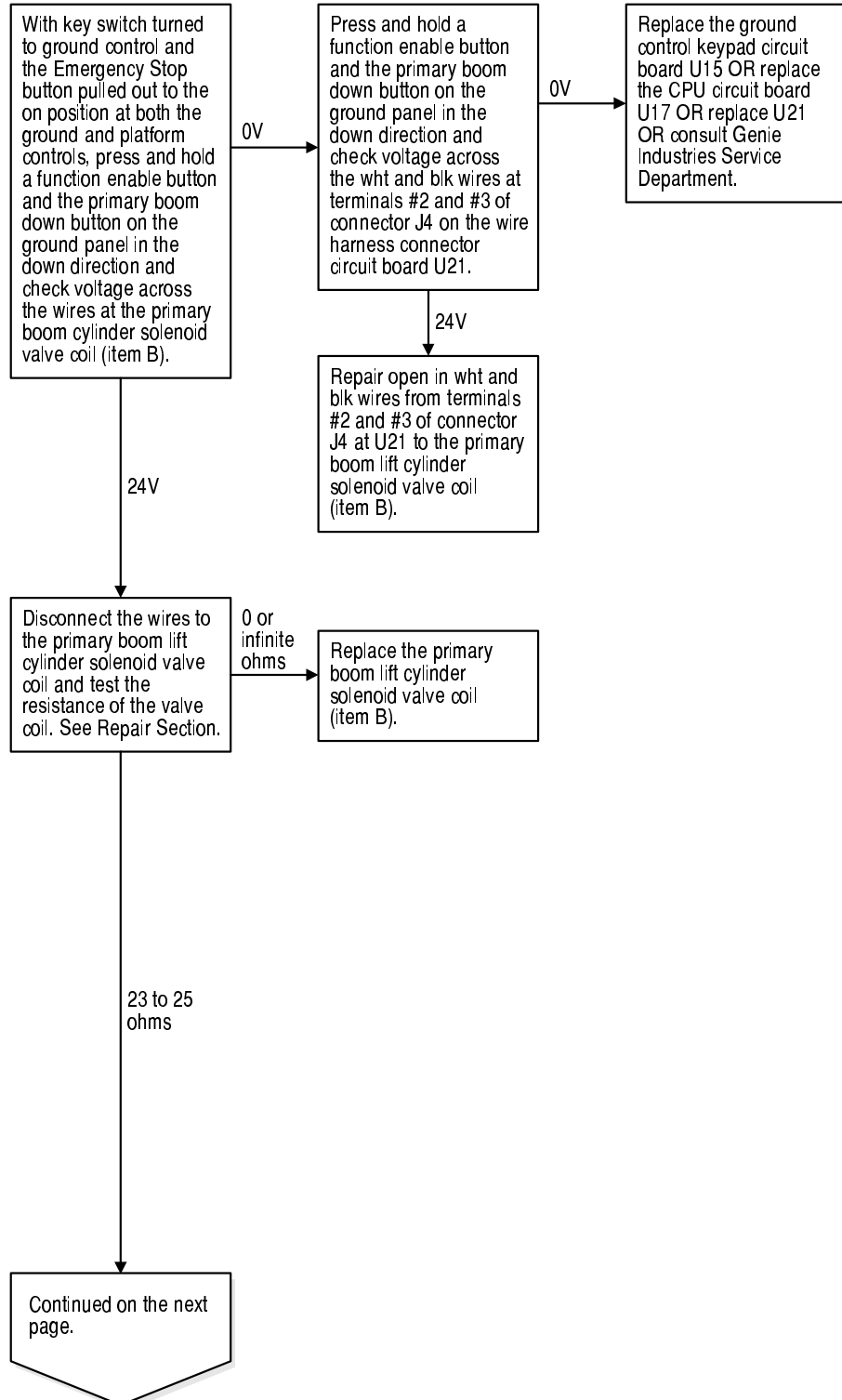

Chart 9

REV B

Primary Boom Down Function Inoperative

Be sure all other functions operate normally.



REV B

CHART 9

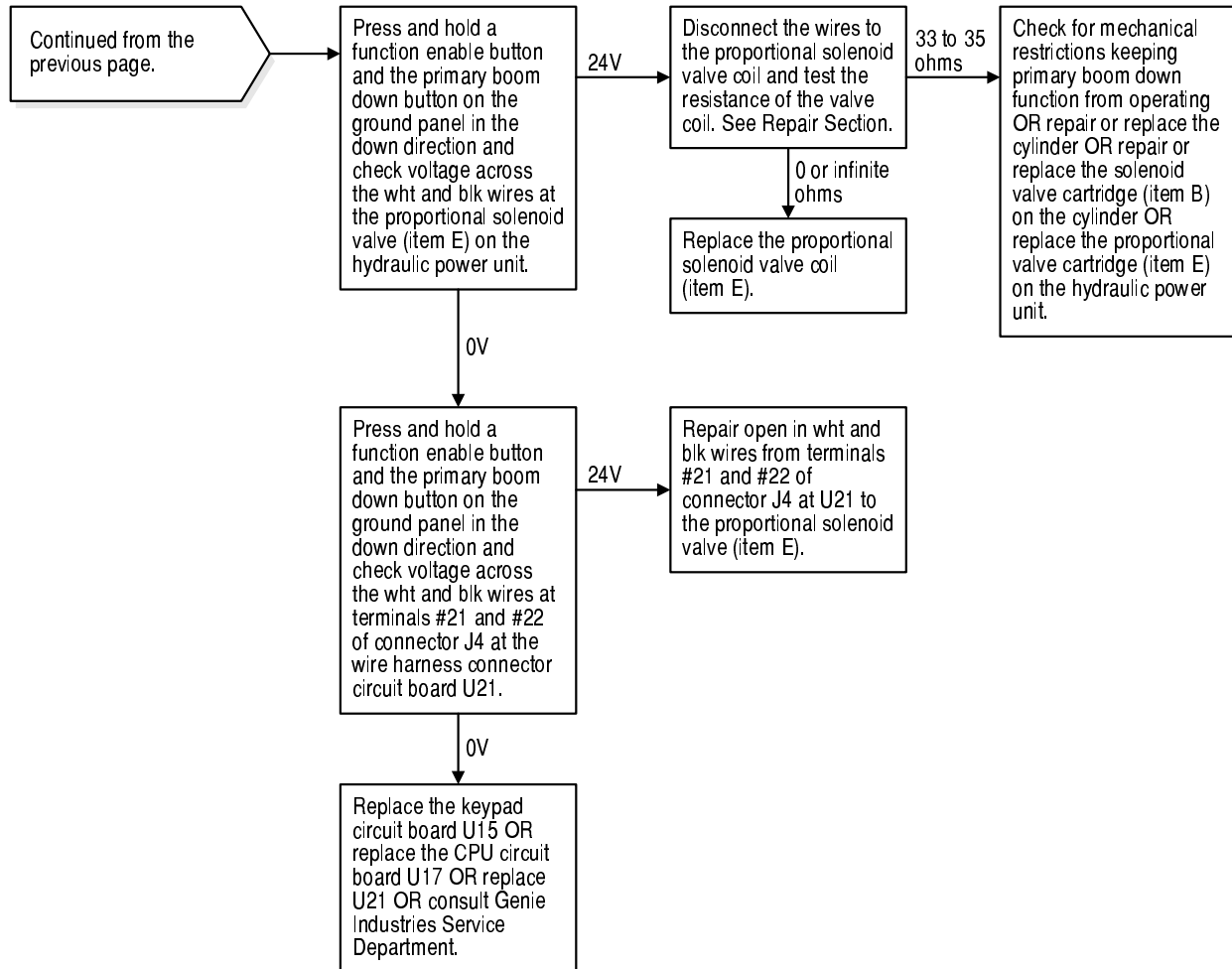

Chart 10

REV B

Secondary Boom Up Function Inoperative

Be sure all other functions operate normally.

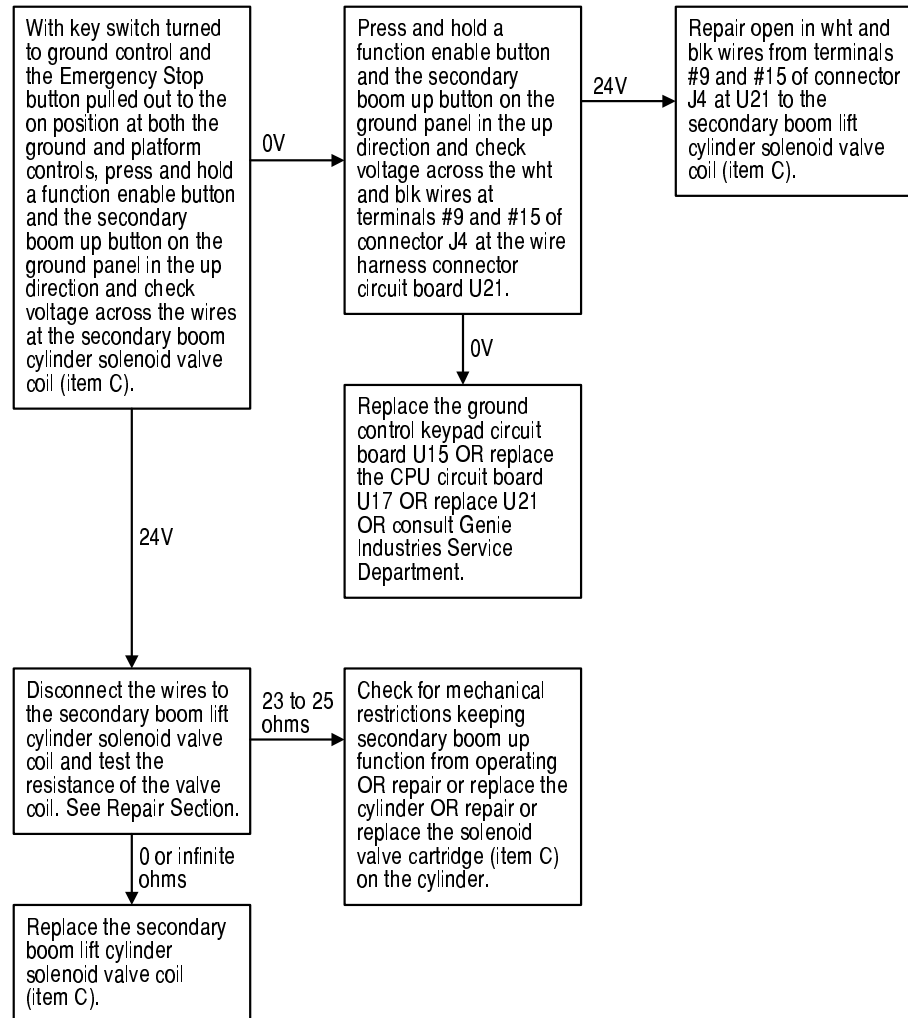

Chart 11

REV B

Secondary Boom Down Function Inoperative

Be sure all other functions operate normally.

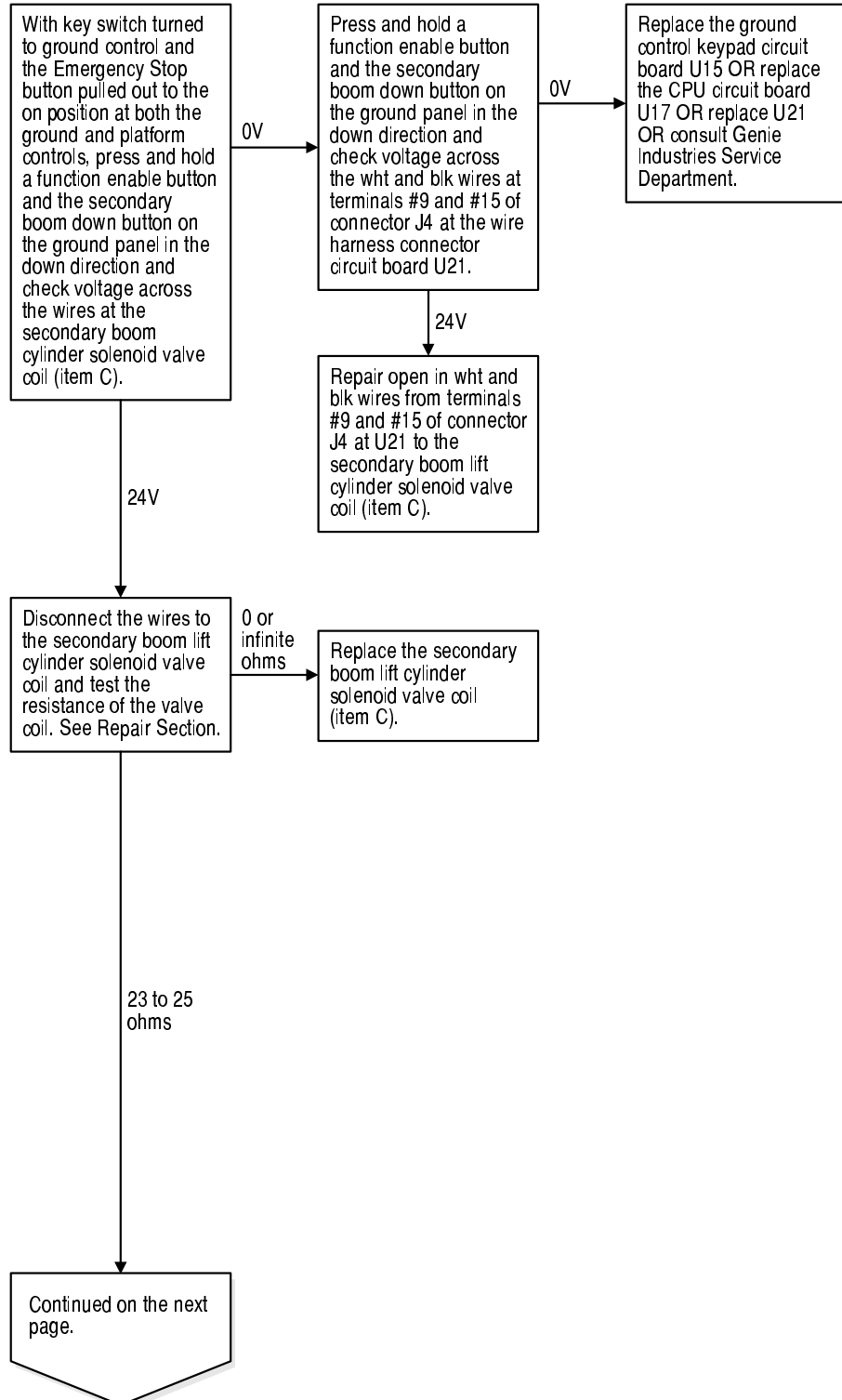

CHART 11

REV B

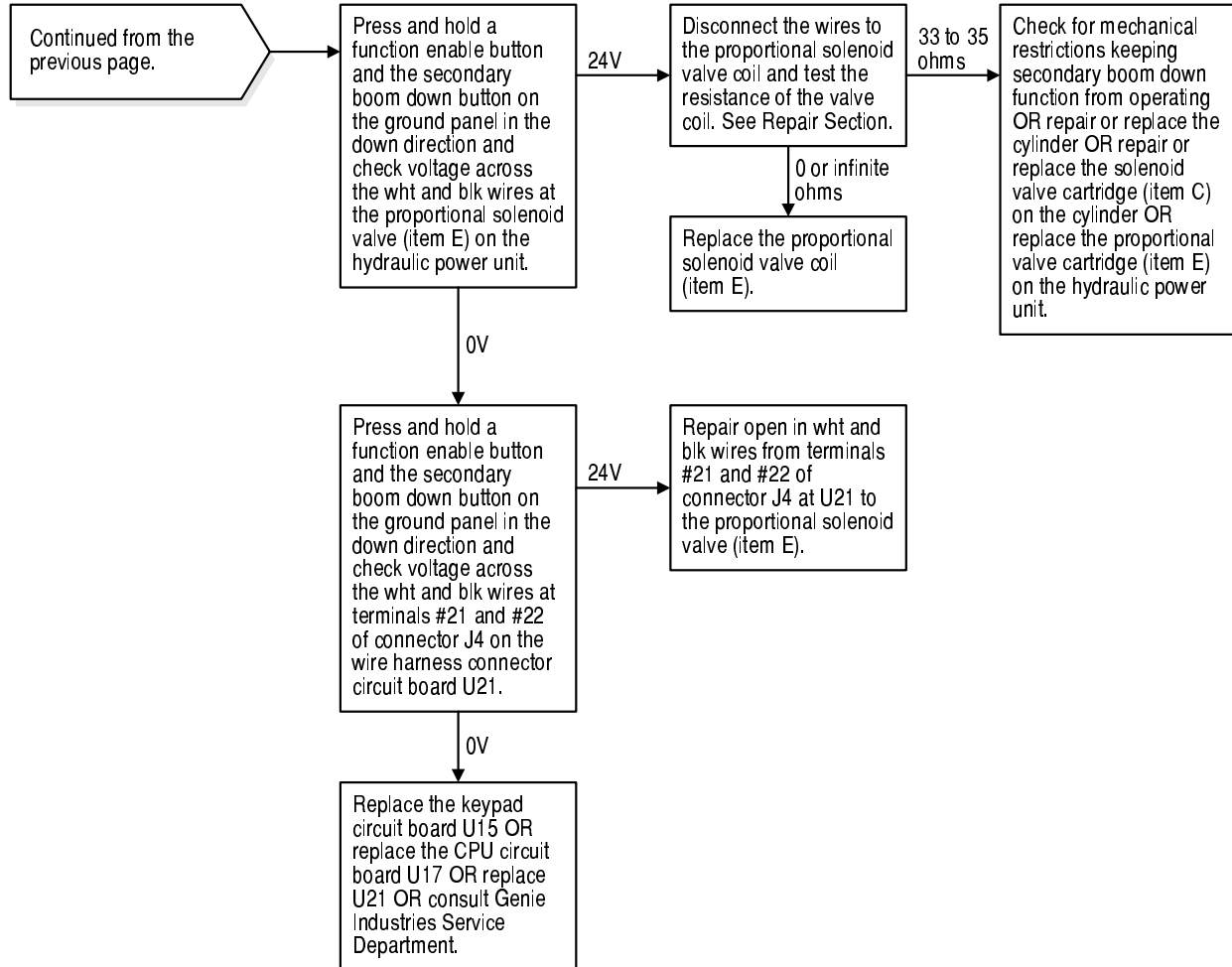

Chart 12

REV B

Turntable Rotate Left Function Inoperative

Be sure all other functions operate normally.

Be sure the needle valve is not in the open position.

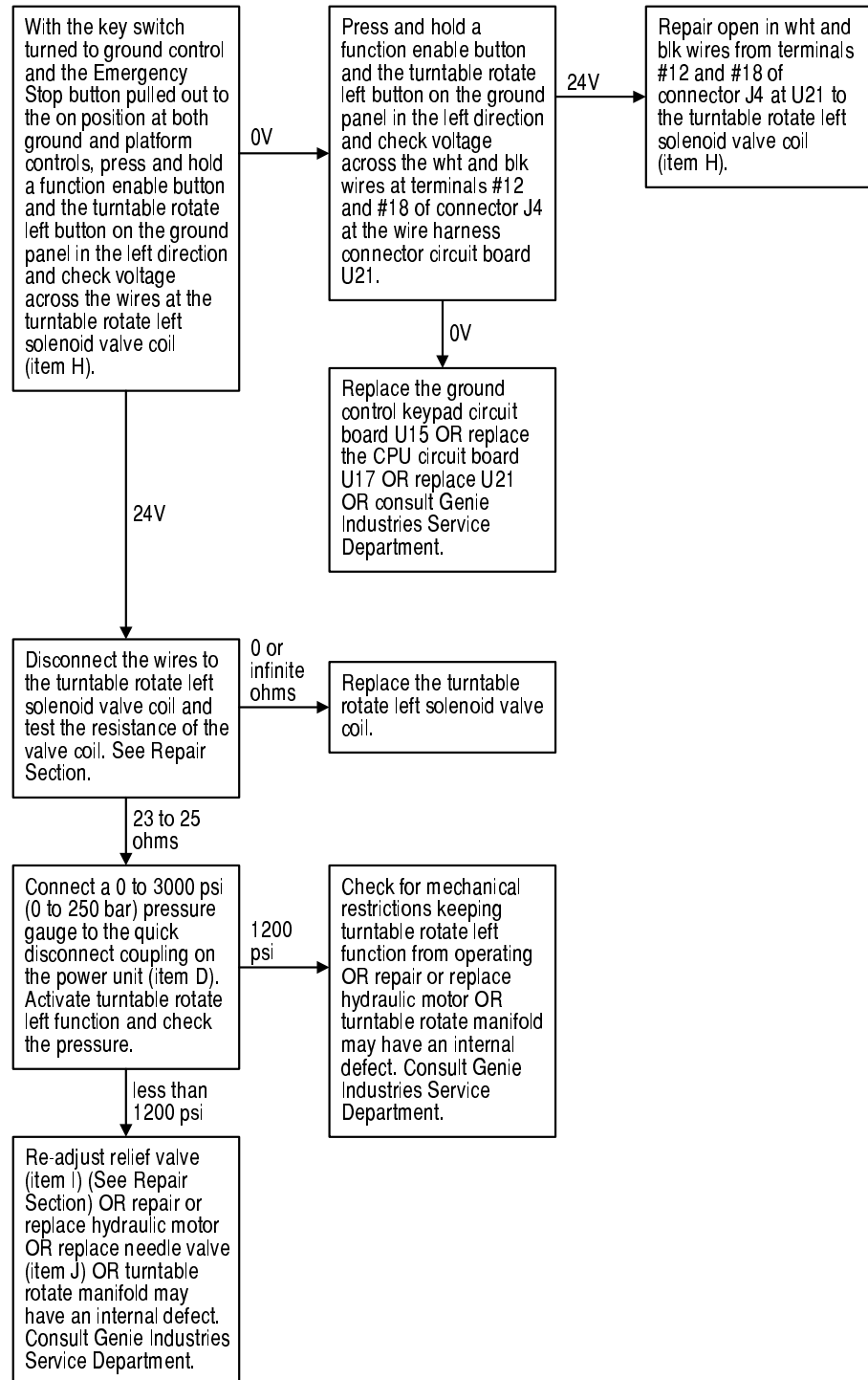

Chart 13

REV B

Turntable Rotate Right Function Inoperative

Be sure all other functions operate normally.

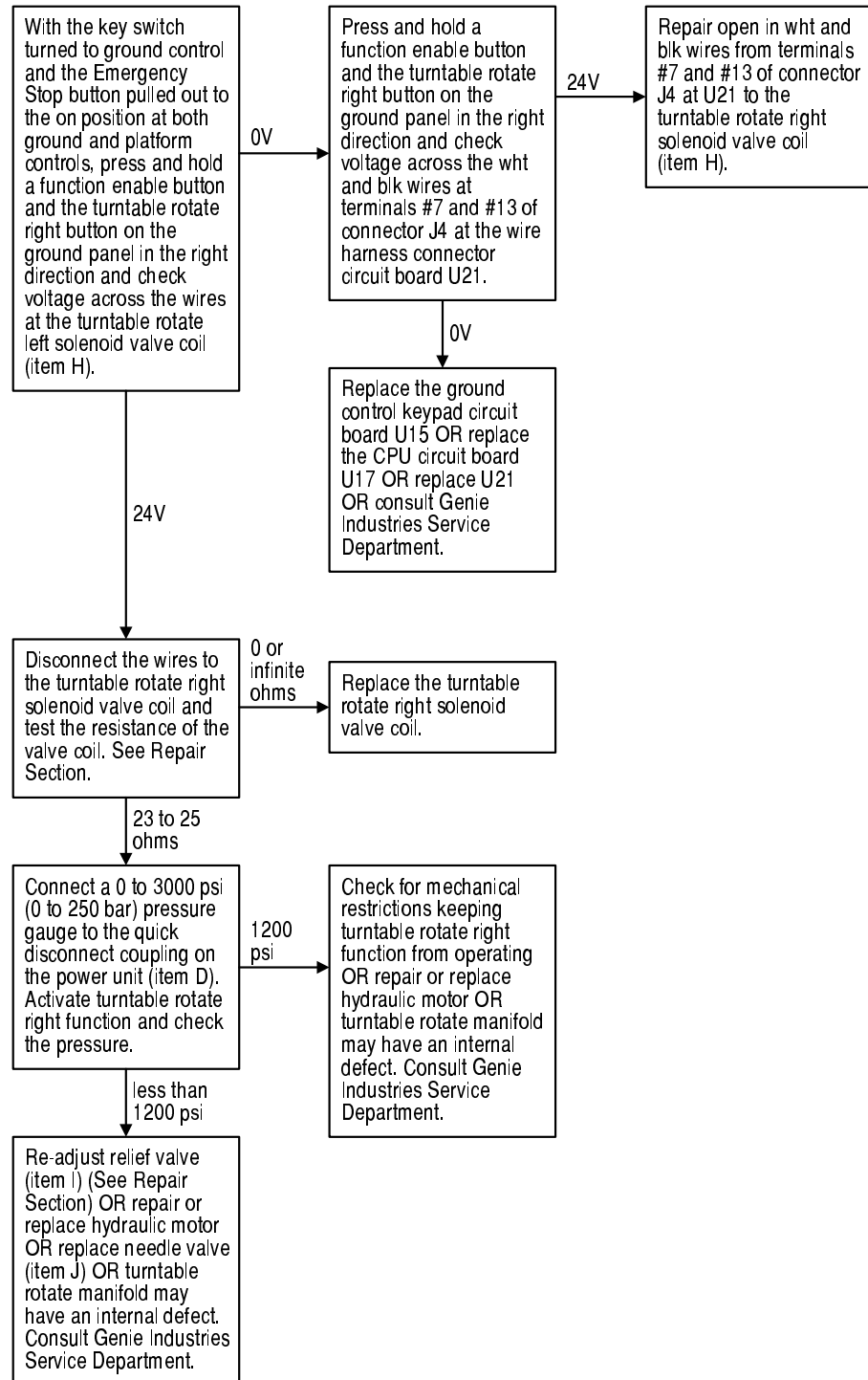
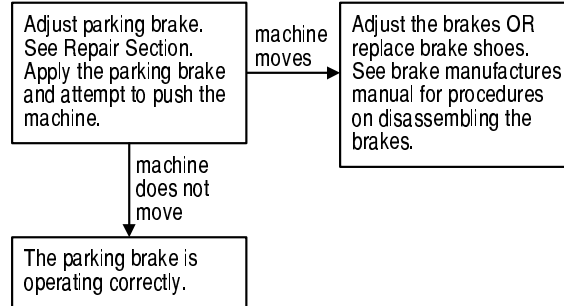

Chart 14

REV A

Parking Brake Function Inoperative

Be sure that the parking brake cables are properly connected and are in good condition.



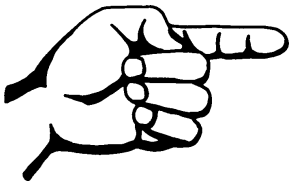

This page intentionally left blank.

Schematics



Observe and Obey:

- ☑ Troubleshooting and repair procedures shall be completed by a person trained and qualified on the repair of this machine.
- ☑ Immediately tag and remove from service a damaged or malfunctioning machine.
- ☑ Repair any machine damage or malfunction before operating the machine.

Before Troubleshooting:

- ☑ Read, understand and obey the safety rules and operating instructions in the appropriate operator's manual on your machine.
- ☑ Be sure that all necessary tools and test equipment are available and ready for use.

About This Section

There are two groups of schematics in this section. An illustration legend precedes each group of drawings.

Electrical Schematics

▲WARNING Electrocutation hazard. Contact with electrically charged circuits could result in death or serious injury. Remove all rings, watches and other jewelry.

Hydraulic Schematics

▲WARNING Bodily injury hazard. Spraying hydraulic oil can penetrate and burn skin. Loosen hydraulic connections very slowly to allow the oil pressure to dissipate gradually. Do not allow oil to squirt or spray.

General Repair Process

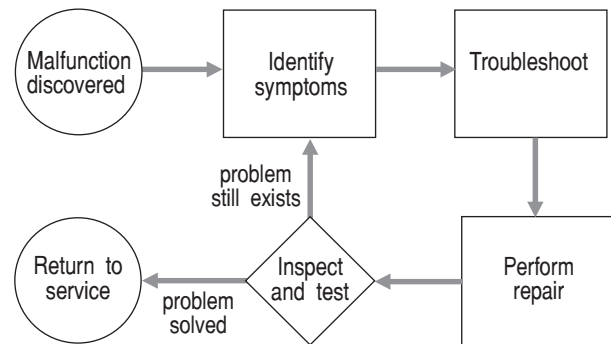

Electrical Component and Wire Color Legends

REV B

ABBREVIATION LEGEND	
Item	Description
B5	Four 6V batteries
BN	Button BN5 = Horn BN12 = Function enable high BN13 = Function enable low BN26 = Function enable medium BN27 = Jib boom up BN28 = Jib boom down BN29 = Primary up BN30 = Primary down BN31 = Secondary up BN32 = Secondary down BN33 = Rotate left BN34 = Rotate right BN35 = Horn BN36 = Jib boom up BN37 = Jib boom down BN38 = Primary up BN39 = Primary down BN40 = Secondary up BN41 = Secondary down BN42 = Rotate left BN43 = Rotate right BN44 = Function enable high BN45 = Function enable medium BN46 = Function enable low
CB2	30A Circuit breaker, controls
D7	Voltage regulator
EN	Enclosure EN1 = Platform control box EN2 = Ground control box
F	Fuse F6 = 275A, Function F10 = 5A, System power
FB	Flashing beacons (option)
G	Gauge G6 = Hour meter G7 = Battery charge indicator (option) G8 = Diagnostic display
H	Horn or alarm H1 = Horn H5 = Multifunction alarm
KS1	Key switch

WIRE COLOR LEGEND	
Color	Description
BK	Black
BL	Blue
GN	Green
OR	Orange
RD	Red
WH	White
YL	Yellow

ABBREVIATION LEGEND	
Item	Description
L	Light or LED L5 = Power (ground) L12 = Left front outrigger L13 = Right front outrigger L14 = Left rear outrigger L15 = Right rear outrigger L18 = Emergency Stop (platform) L19 = Power (platform) L33 = Right rear tail light L34 = Left rear tail light L35 = Right side marker L36 = Left side marker L45 = Emergency Stop (ground)
LS	Limit switch LS1 = Structure retract LS2 = Primary boom up LS11 = Jib boom down LS12 = Left front outrigger LS13 = Right front outrigger LS14 = Left rear outrigger LS15 = Right rear outrigger LS17 = Negative boom angle LS27 = Turntable
M5	Hydraulic power unit
N.C.	Normally closed
N.C.H.O.	Normally closed held open
N.O.	Normally open
N.O.H.C.	Normally open held closed
P	Power switch P1 = Emergency Stop button at ground controls P2 = Emergency Stop button at platform controls
QD	Quick disconnect QD1 = Primary battery disconnect QD3 = Control cable at platform QD4 = Control cable at ground QD12 = Trailer connector QD19 = Trailer harness connector
S7	Level sensor
SW	Switch SW13 = Left front outrigger SW14 = Right front outrigger SW15 = Left rear outrigger SW16 = Right rear outrigger SW25 = DIP switch
TB	Terminal base
U	Electronic component U3 = Platform controls circuit board U6 = Motor controller U9 = Battery charger U15 = Key pad circuit board U21 = Connector circuit board U22 = CPU/display circuit board
Y	Valve coil Y9 = Proportional (function) Y23 = Turntable rotate left Y24 = Turntable rotate right Y39 = Outrigger up (retract) Y41 = Outrigger regen Y45 = Primary boom Y46 = Secondary boom Y47 = Jib boom Y48 = Outrigger level

Limit Switch Legend

REV A

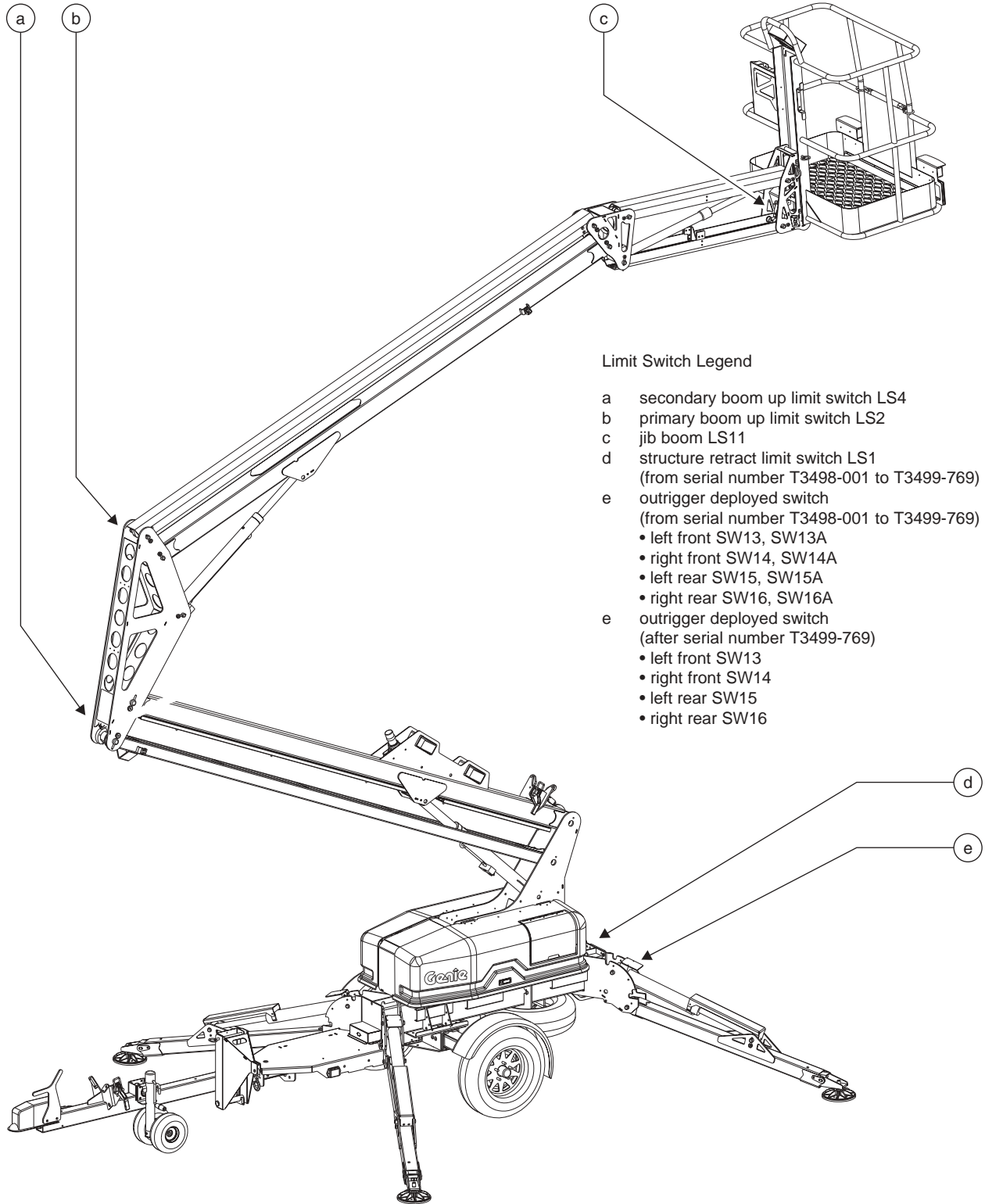

Limit Switch Legend

- a secondary boom up limit switch LS4
- b primary boom up limit switch LS2
- c jib boom LS11
- d structure retract limit switch LS1
(from serial number T3498-001 to T3499-769)
- e outrigger deployed switch
(from serial number T3498-001 to T3499-769)
 - left front SW13, SW13A
 - right front SW14, SW14A
 - left rear SW15, SW15A
 - right rear SW16, SW16A
- e outrigger deployed switch
(after serial number T3499-769)
 - left front SW13
 - right front SW14
 - left rear SW15
 - right rear SW16

Trailer Lighting Wiring Diagram

REV A

ANSI, CSA Models

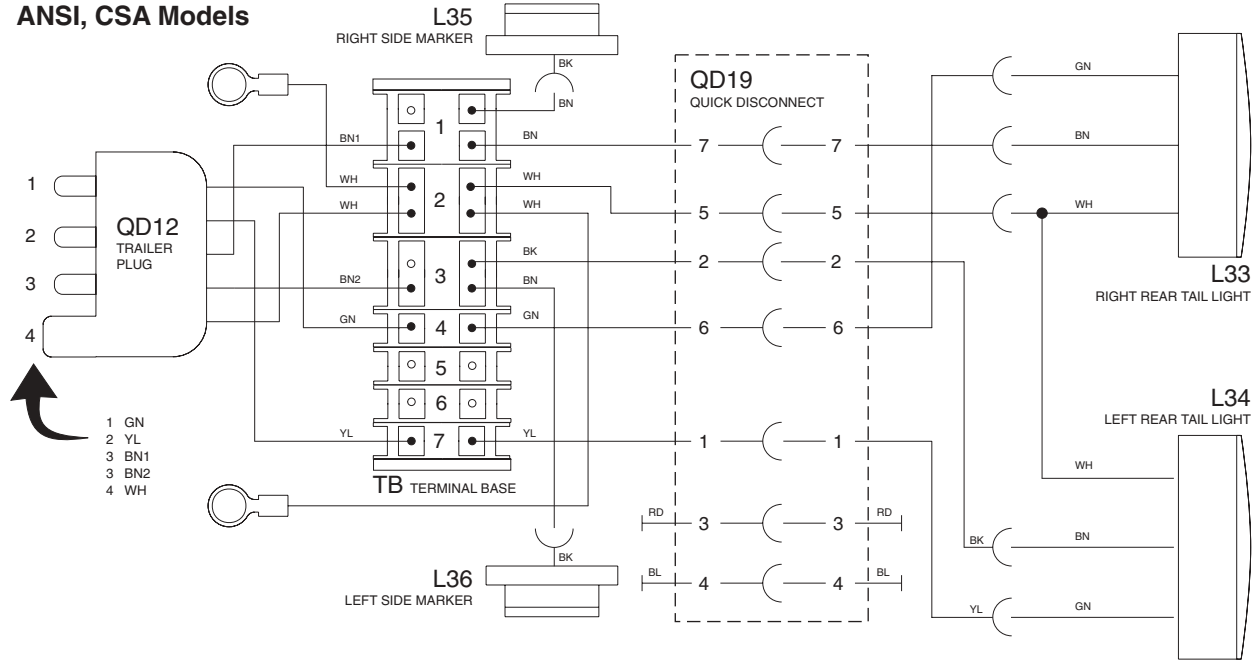

CE Models

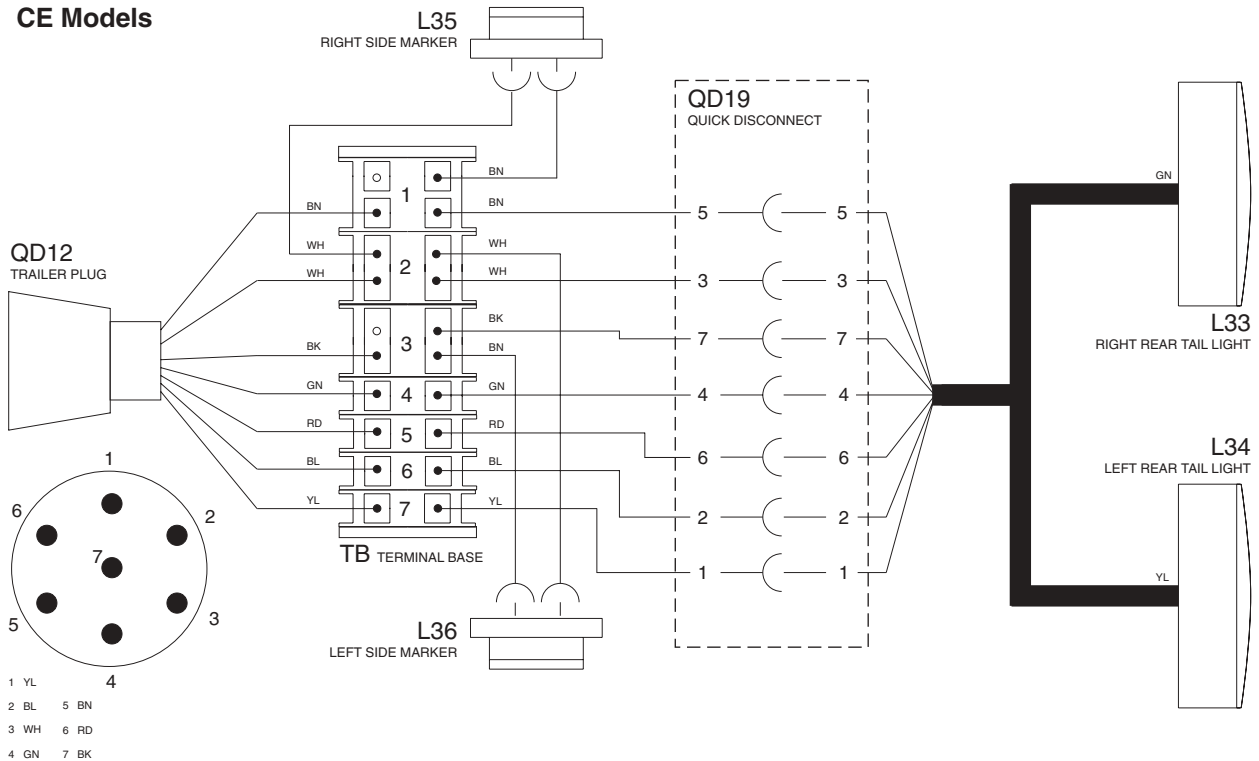

Electrical Symbols Legend

REV A

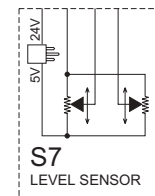
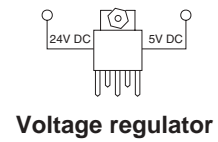
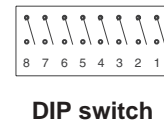
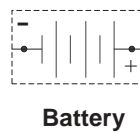
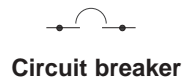
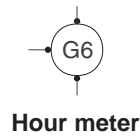
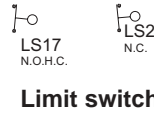
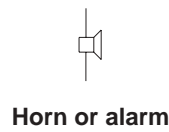
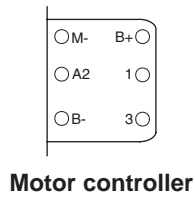
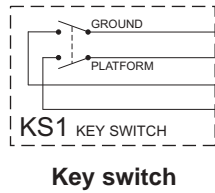
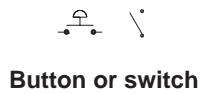
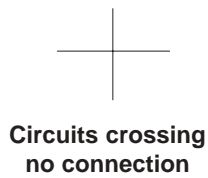
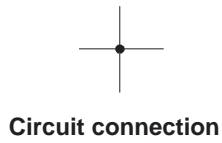

Electrical Schematic

Models with Manual Outriggers
(from serial number T3498-001 to T3499-361)

REV B

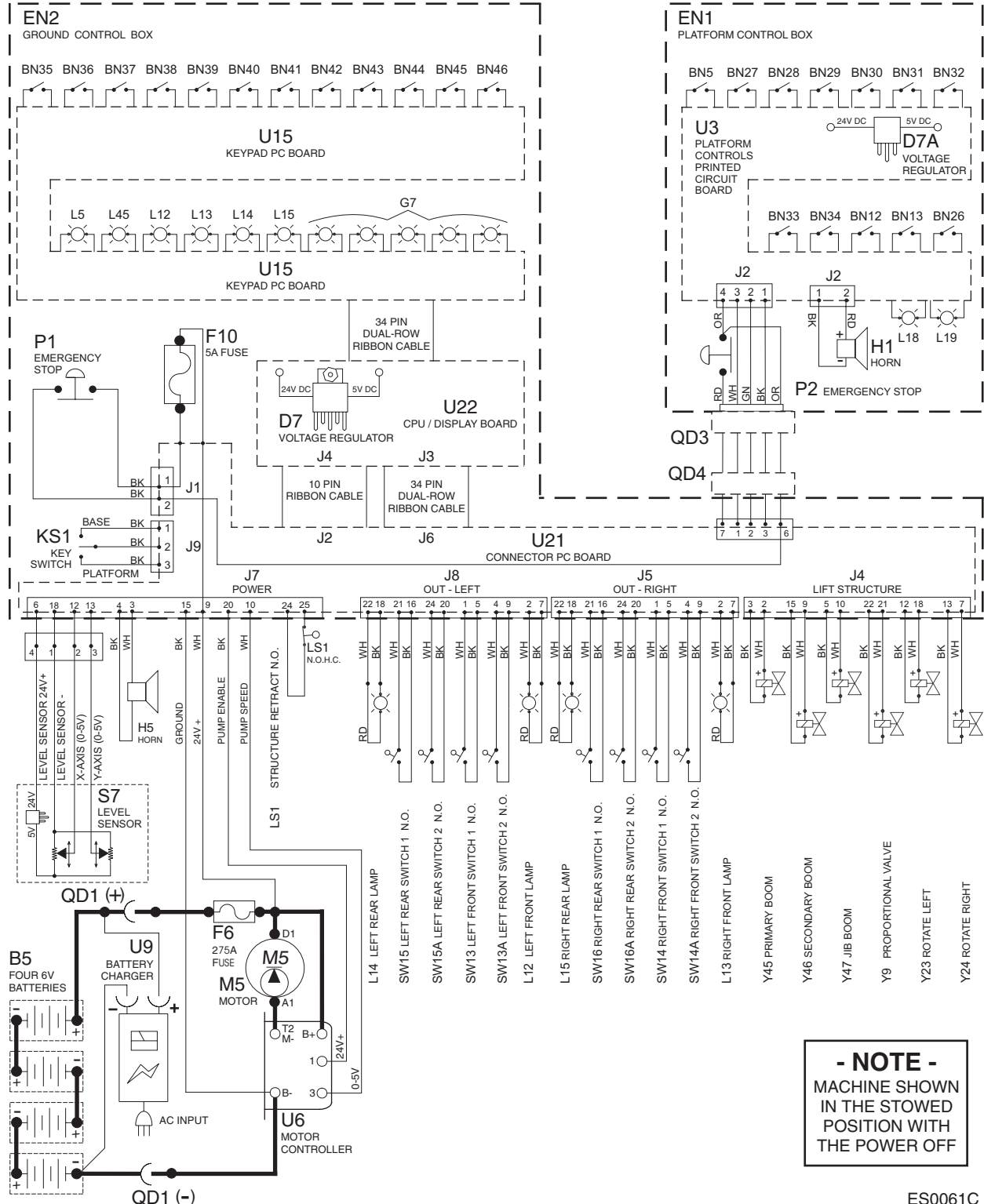

ES0061C



Electrical Schematic

Models with Manual Outriggers

(from serial number T3499-362 to T3499-769)

REV A

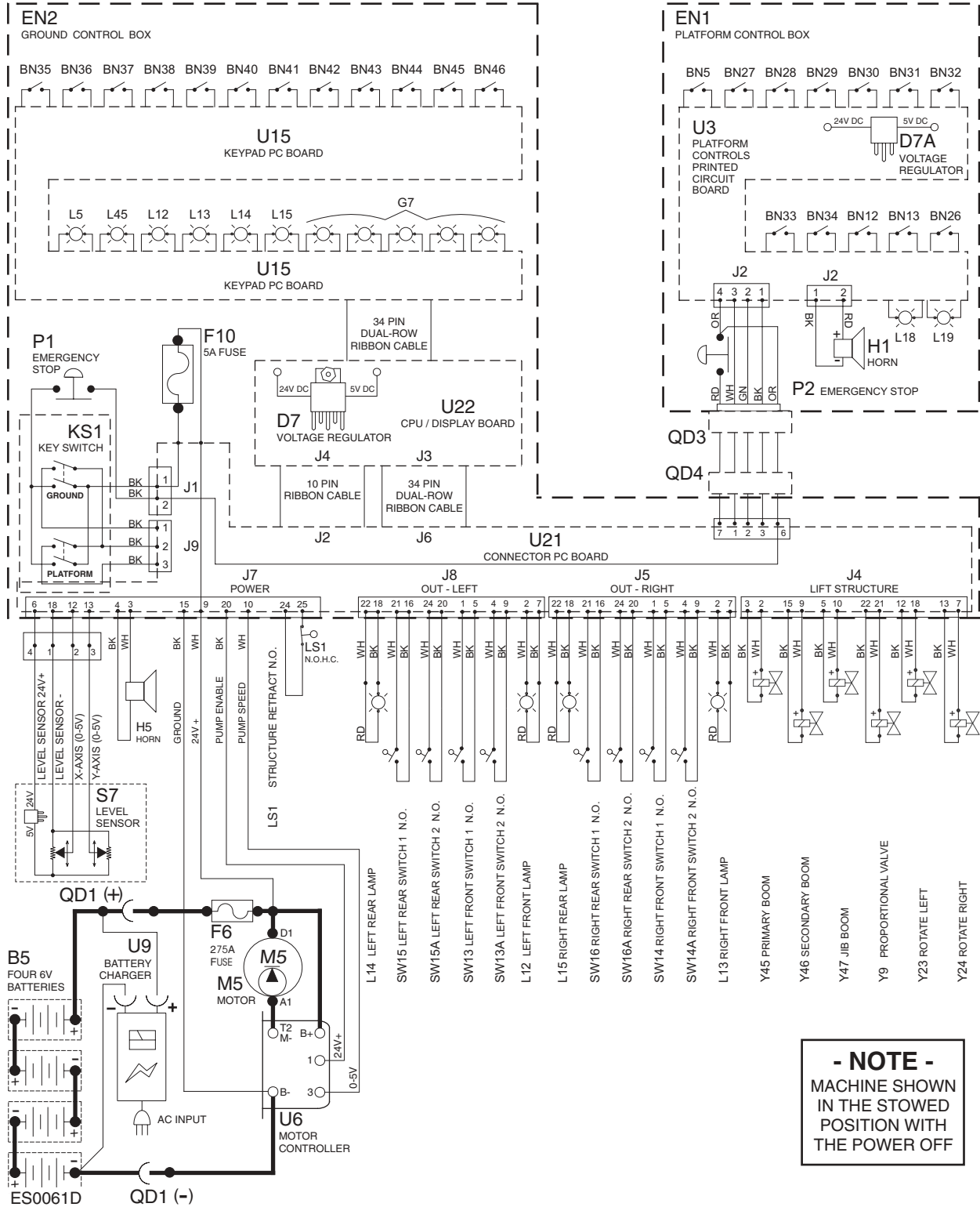

Electrical Schematic

Models with Manual Outriggers
(from serial number T3400-001)

REV B

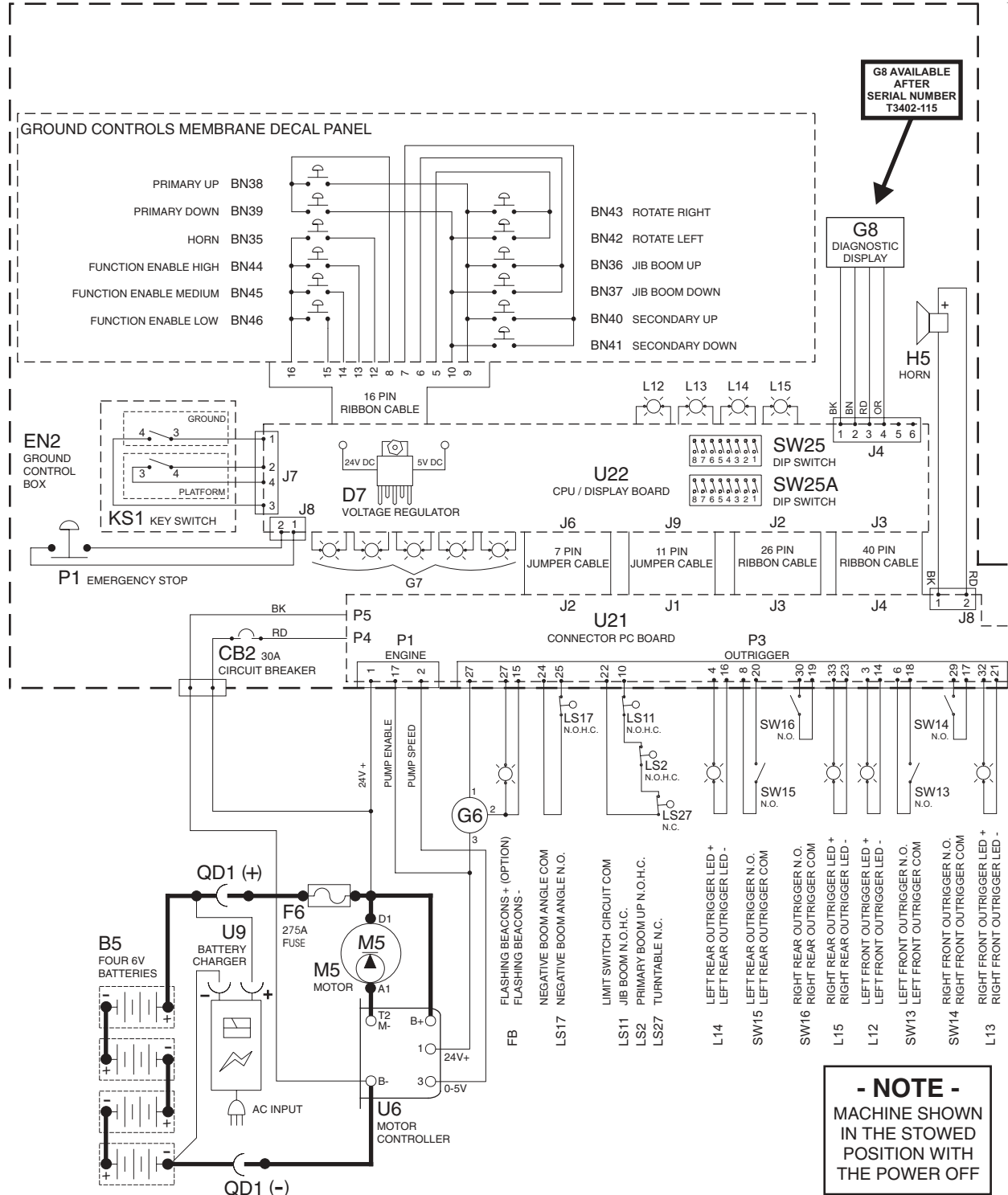

- NOTE -
MACHINE SHOWN
IN THE STOWED
POSITION WITH
THE POWER OFF

ES0209D
ES0209F



REV B

Electrical Schematic

Models with Manual Outriggers
(from serial number T3400-001)

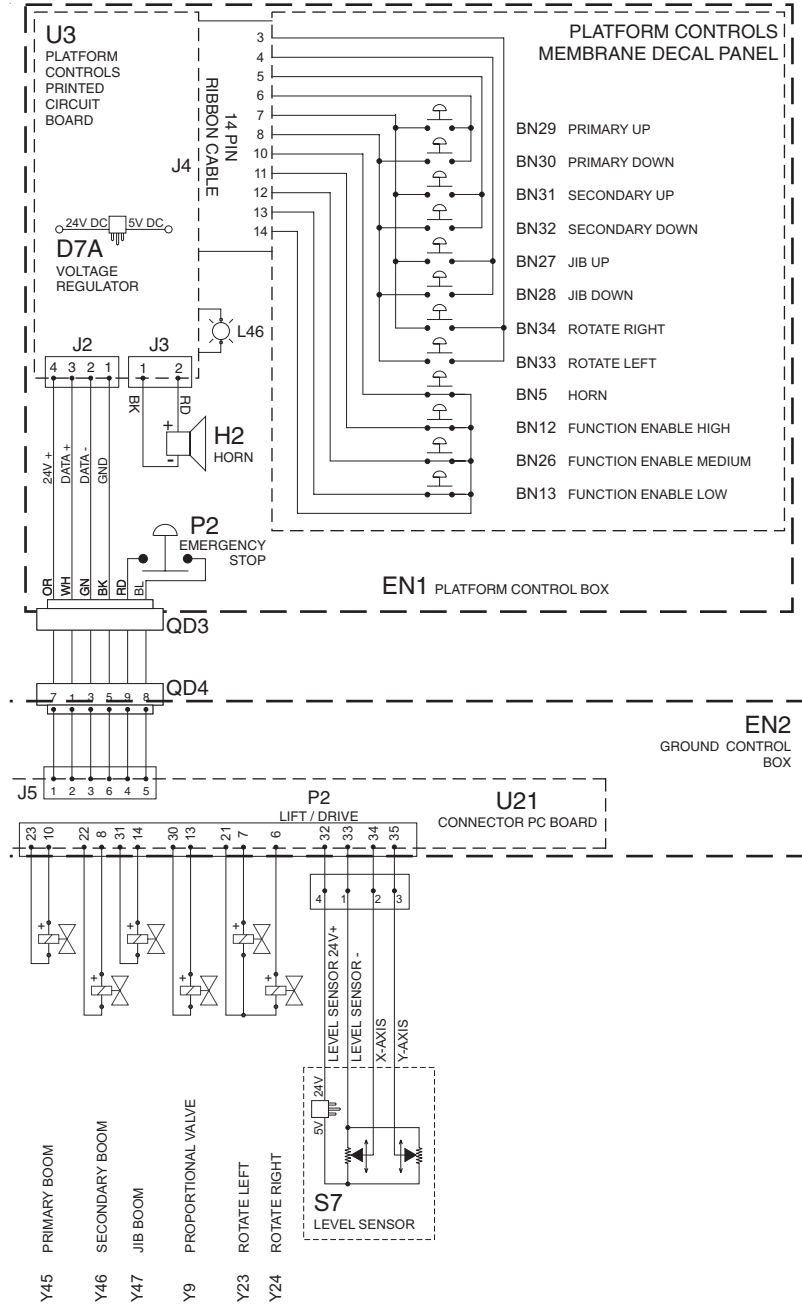

- NOTE -
MACHINE SHOWN
IN THE STOWED
POSITION WITH
THE POWER OFF

ES0209D
ES0209F



Electrical Schematic

Models with Hydraulic Outriggers

REV B

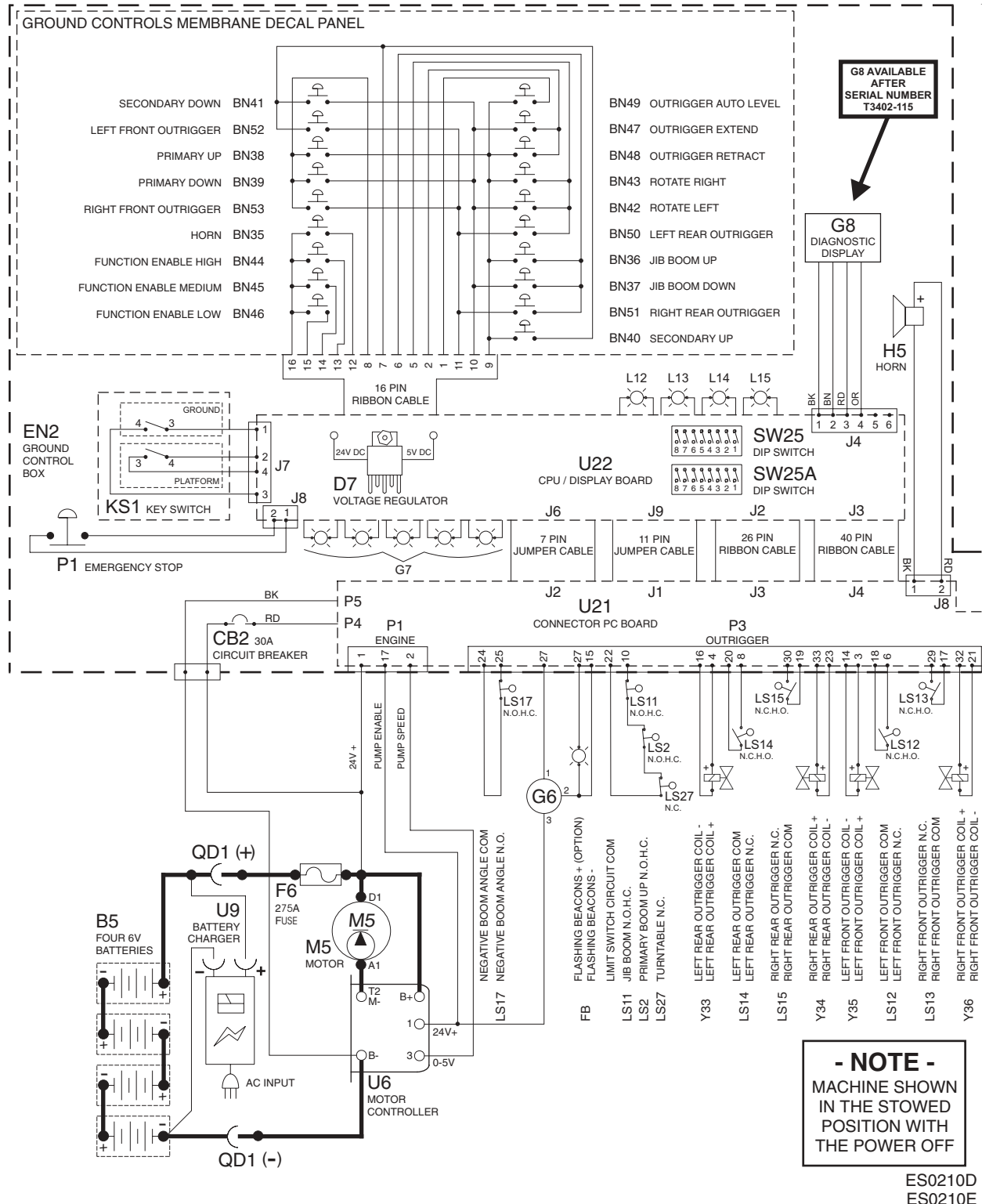

REV B

Electrical Schematic

Models with Hydraulic Outriggers

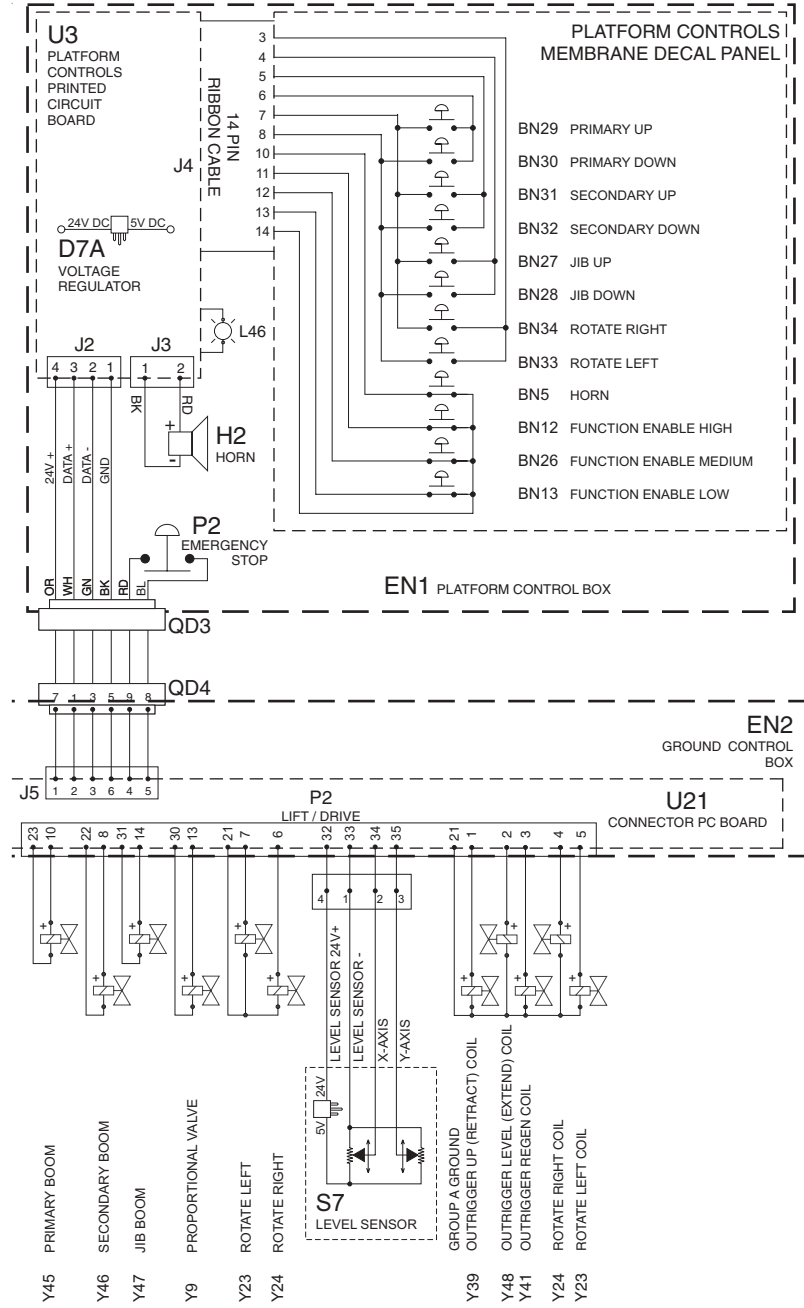

- NOTE -
MACHINE SHOWN
IN THE STOWED
POSITION WITH
THE POWER OFF

ES0210D
ES0210E



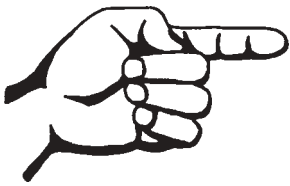

This page intentionally left blank.

REV A

Hydraulic Symbols Legend and Component Reference

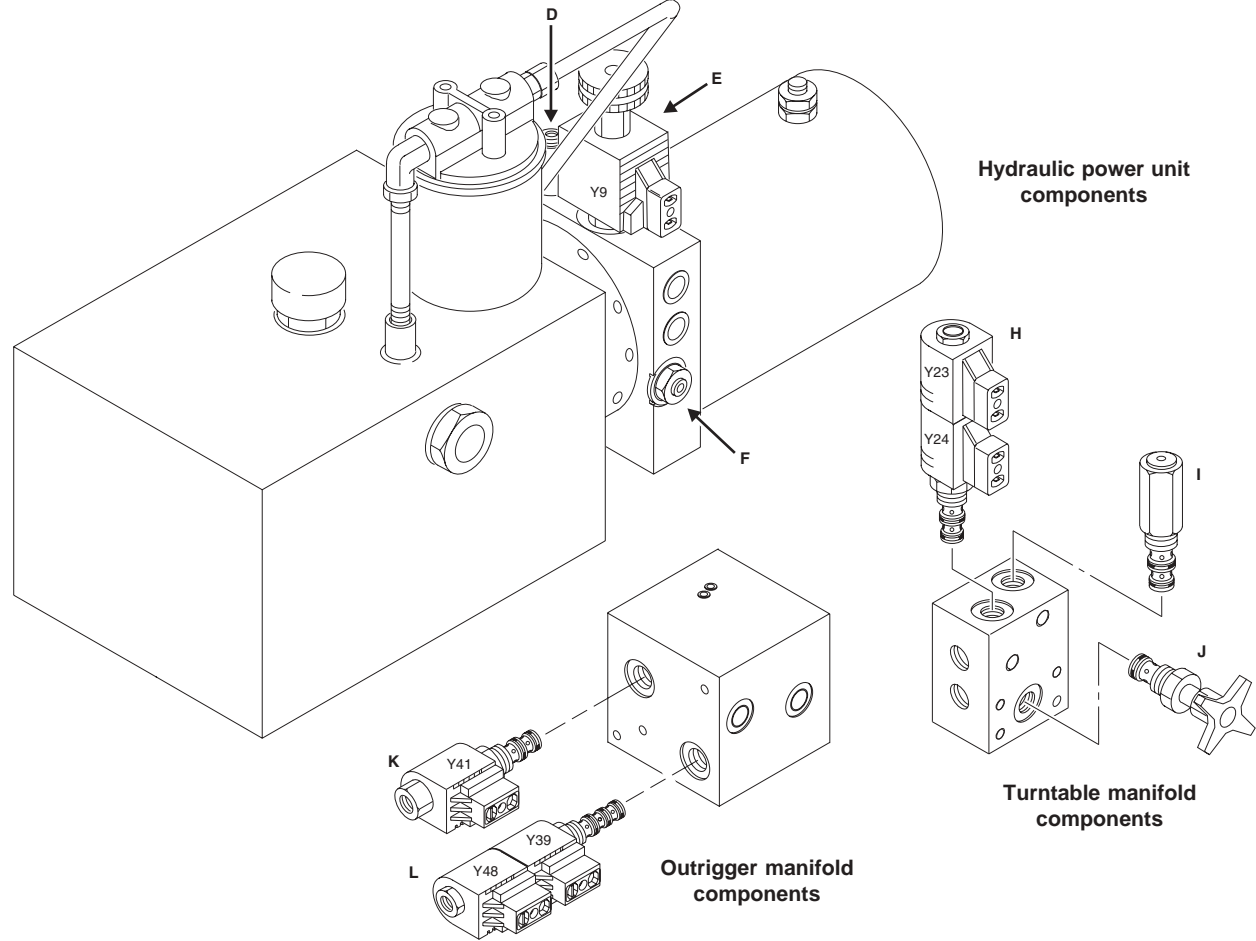
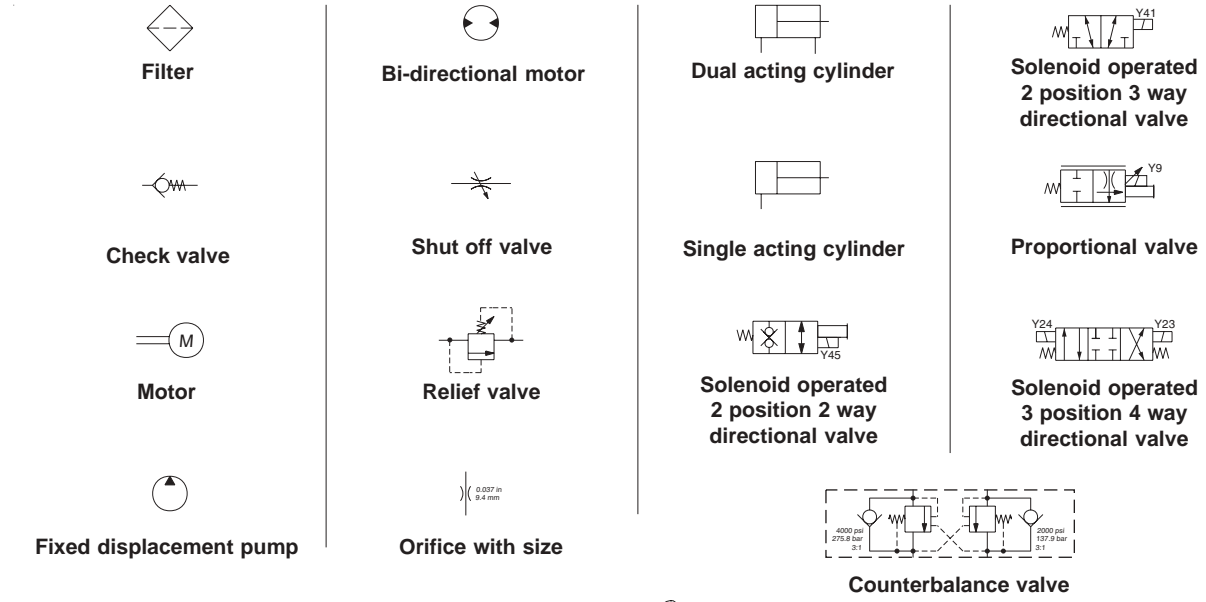

Hydraulic Schematic

Models with Manual Outriggers
(from serial number T3498-001 to T3499-769)

REV A

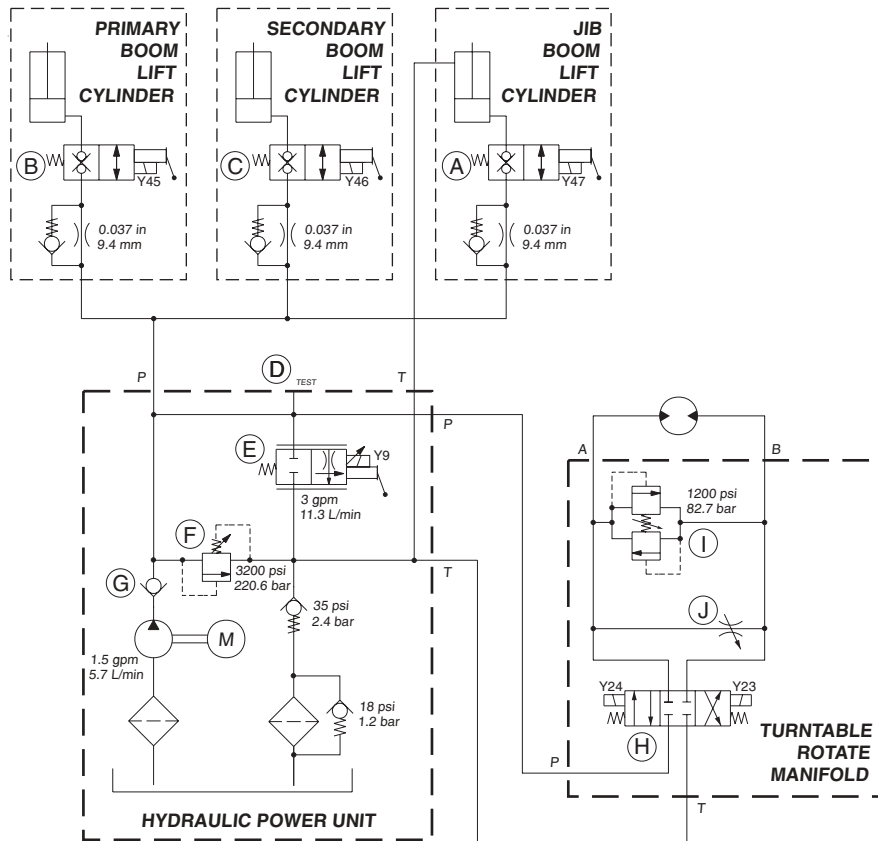

HS00007A

REV A

Hydraulic Schematic

Models with Manual Outriggers
(from serial number T3400-001 to T3400-265)

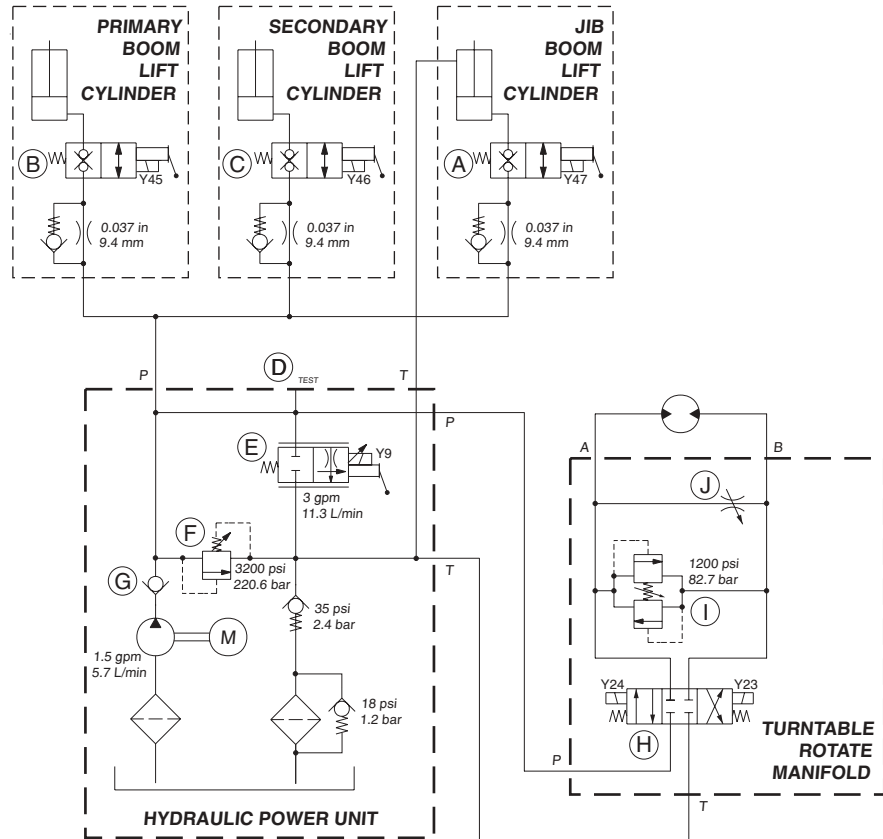

HS0132A

Hydraulic Schematic

Models with Manual Outriggers
(after serial number T3400-265)

REV A

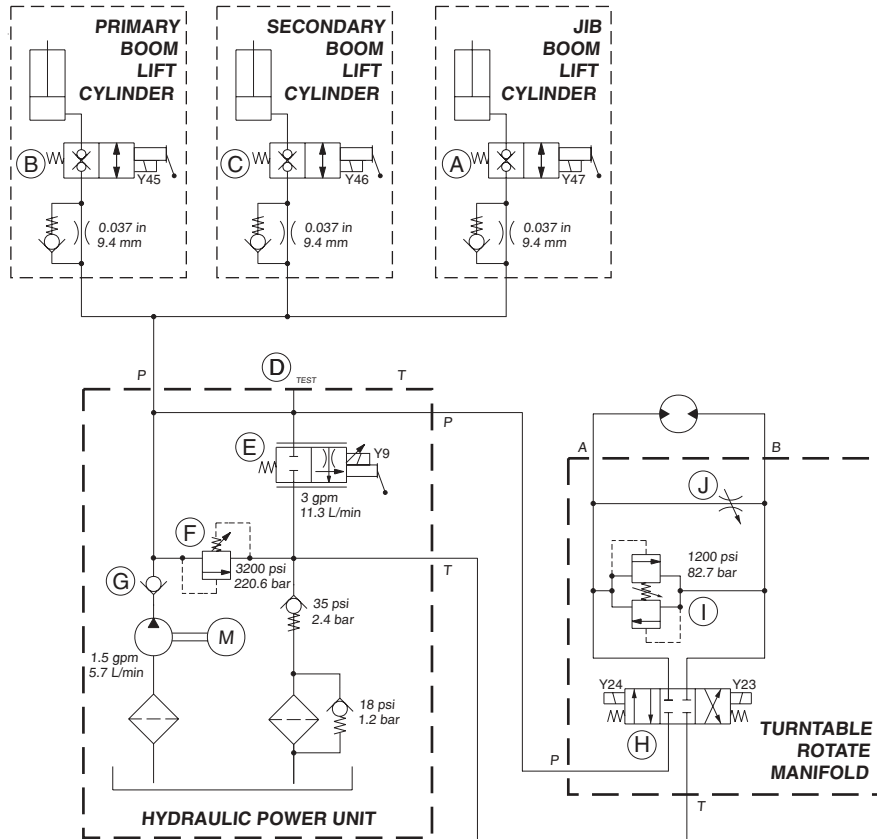

HS0132B

REV A

Hydraulic Schematic

Models with Hydraulic Outriggers
(before serial number T3400-266)

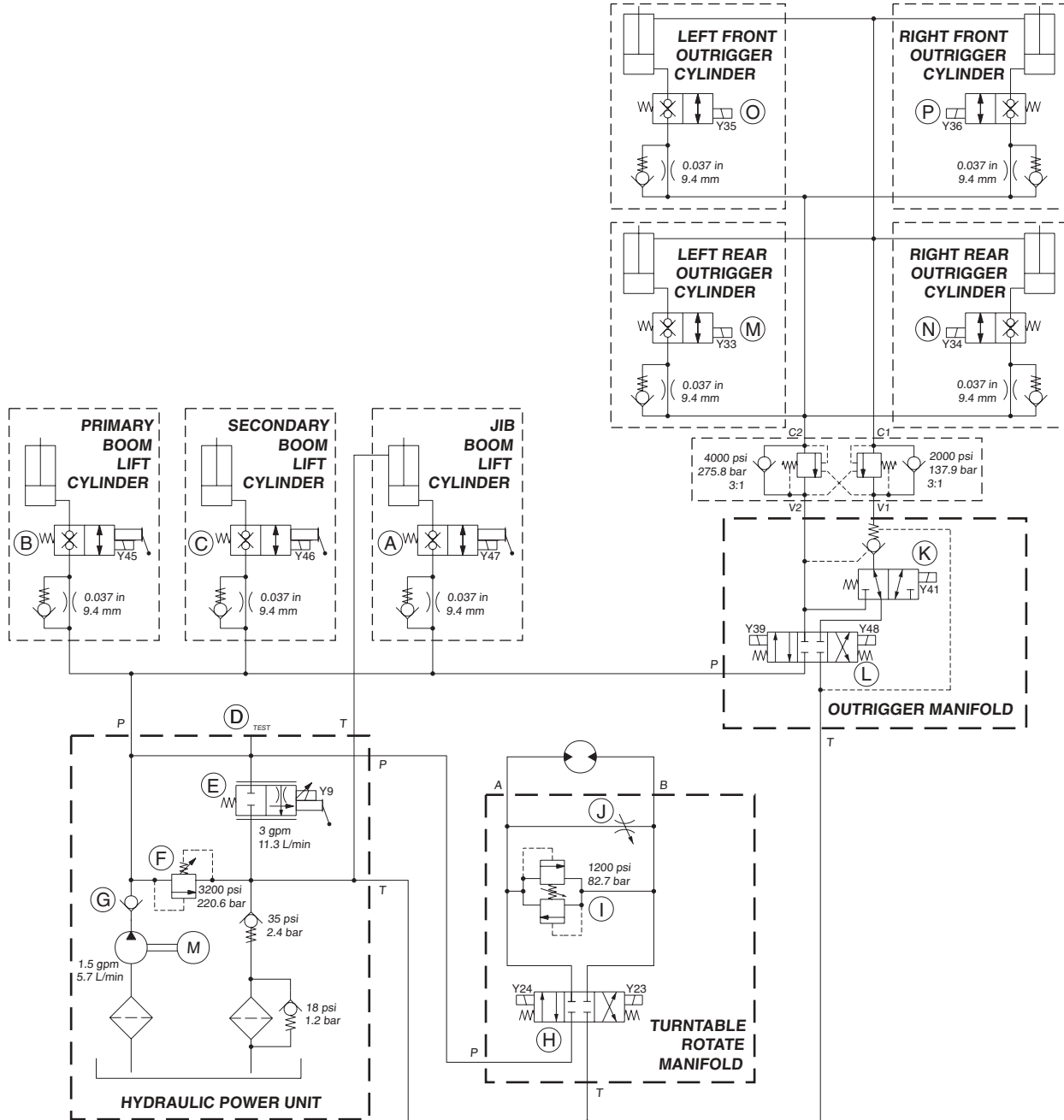

HS0133A



Hydraulic Schematic

Models with Hydraulic Outriggers
(after serial number T3400-265)

REV A

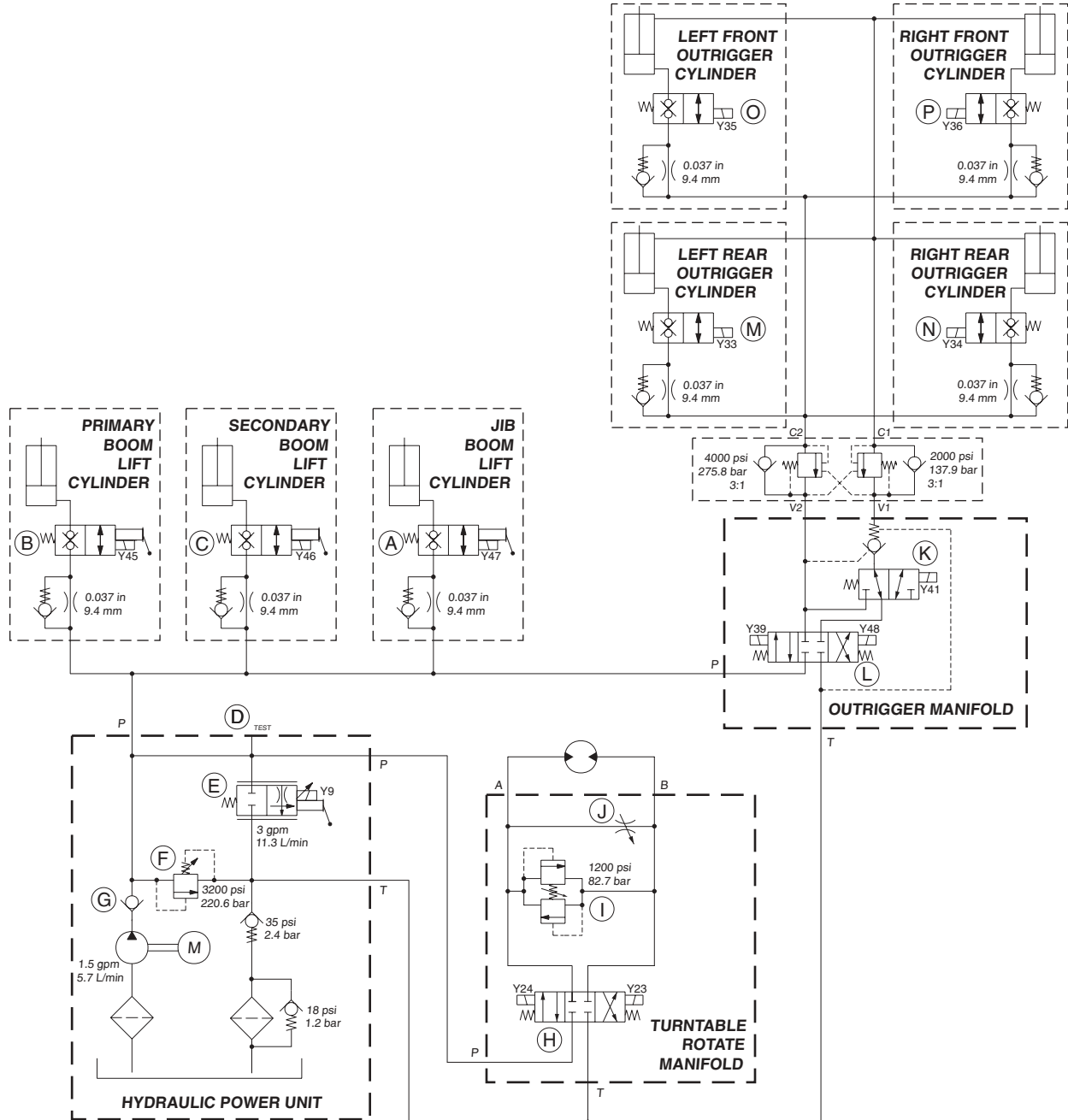

HS0133B



Genie Scandinavia
Phone +46 31 575100
Fax +46 31 579020

Genie France
Phone +33 (0)2 37 26 09 99
Fax +33 (0)2 37 26 09 98

Genie Iberica
Phone +34 93 579 5042
Fax +34 93 579 5059

Genie Germany
Phone 0800 180 9017
Phone +49 422 149 1818
Fax +49 422 149 1820

Genie U.K.
Phone +44 (0)1476 584333
Fax +44 (0)1476 584334

Genie Mexico City
Phone +52 55 5666 5242
Fax +52 55 5666 3241

Genie North America
Phone 425.881.1800
Toll Free USA and Canada
800.536.1800
Fax 425.883.3475

Genie Australia Pty Ltd.
Phone +61 7 3375 1660
Fax +61 7 3375 1002

Genie China
Phone +86 21 53852570
Fax +86 21 53852569

Genie Malaysia
Phone +65 98 480 775
Fax +65 67 533 544

Genie Japan
Phone +81 3 3453 6082
Fax +81 3 3453 6083

Genie Korea
Phone +82 25 587 267
Fax +82 25 583 910

Genie Brasil
Phone +55 11 41 665 755
Fax +55 11 41 665 754

Genie Holland
Phone +31 183 581 102
Fax +31 183 581 566

Distributed By:

Service Manual TMZ-34/19

**Part No.
52075**

Rev C

Genie
A TEREX COMPANY